

Professional Powered Speakers

EUROLIVE F1320D

Active 300-Watt 2-Way Monitor Speaker System with 12" Woofer, 1" Compression Driver and Feedback Filter

- High-power 300-Watt 2-way monitor speaker system for live and playback applications
- Exceptional sound quality, wide frequency bandwidth and dynamic range
- Revolutionary Class-D amplifier technology: enormous power, incredible sonic performance and super-light weight
- Adjustable feedback filter and integrated limiter for ultimate system control and speaker protection
- Integrated sound processor for ultimate system control and speaker protection
- Ultra-low noise Mic/Line input with Volume control and Clip LED
- Dedicated 3-band EQ for perfect sound shaping
- Extremely powerful 12" long-excursion driver provides incredibly deep bass and acoustic power
- High-resolution 1" HF driver for exceptional high-frequency reproduction
- Proprietary horn design for ultra-wide sound dispersion
- Internal switch-mode power supply for noise-free audio, superior transient response and very low power consumption
- Integrated 35 mm pole socket for stand mounting and use as PA system
- High-quality components and exceptionally rugged construction ensure long life
- Conceived and designed by BEHRINGER Germany



Since its introduction, the EUROLIVE F1220A active floor monitor has been wildly successful. Building on that legacy, we are proud to present the even more powerful EUROLIVE F1320D. This 300-Watt active monitor system has its own 3-band EQ and dedicated volume knob, so you not only have control of the output, but you can tweak the highs, mids and lows for a clear, true sense of your performance. And thanks to our Class-D technology, the F1320D weighs less than 40 lbs (18 kg), making them easy to transport and set up. The built-in adjustable feedback filter helps eliminate annoying squeals and howls so you can crank the volume to a level where you can actually hear yourself above the raging chaos, otherwise known as your band. After all, the main reason to have a monitor is so you can hear yourself,

right? The EUROLIVE F1320D helps you hear yourself better so you can perform up to your true potential.

Beauty is Much More Than Skin Deep

Inside these active monitors is the equivalent of a 2-way electronic crossover, a graphic equalizer, a parametric equalizer, a mic preamp and two power amplifiers! A long-excursion 12" driver delivers deep, punchy low end while the 1" compression driver, mounted in a custom-designed horn, provides ultra-wide dispersion of clean, crisp highs. These systems work together seamlessly, cranking out 300 Watts of super-clean power, and here's the best part—you don't have to be a sound engineer to run it!

Continued on next page



EUROLIVE F1320D

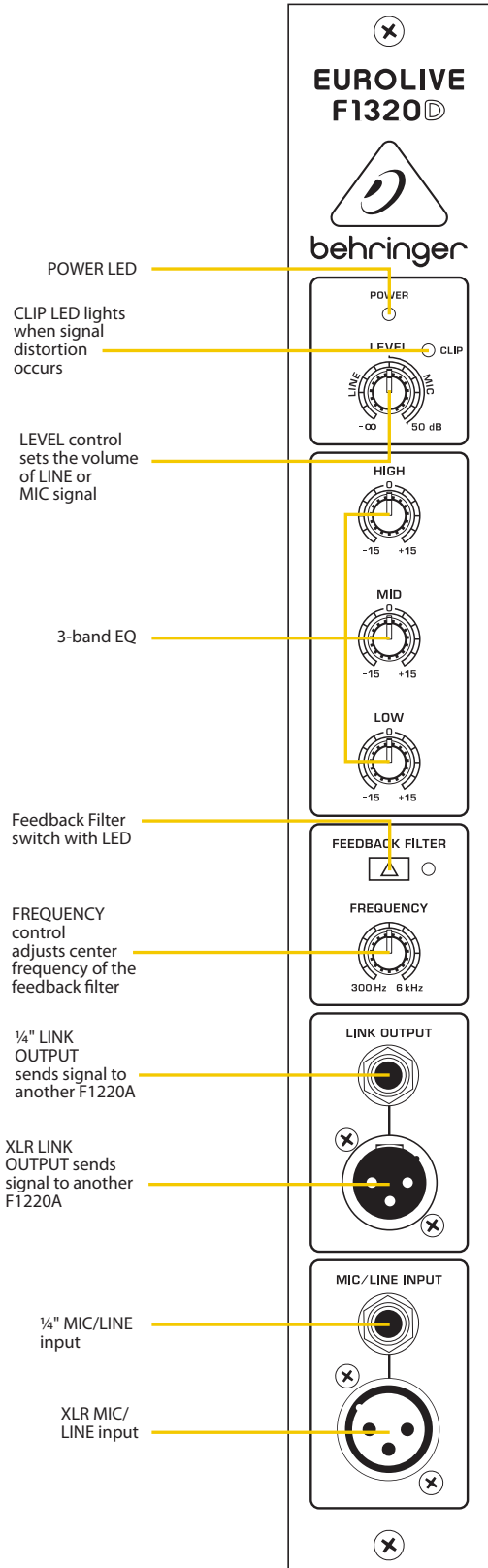

Class-D Amplifier Technology

Our revolutionary Class-D amplifier technology enables us to make floor monitors that weigh about the same as their passive cousins, even with a built-in 300-Watt amplifier! Class-D amps are super-efficient little beauties that don't generate as much heat as their conventional counterparts, so they don't need massive heat sinks to keep them cool. We combine these powerful amplifiers with state-of-the-art switch-mode power supplies for noise-free audio, superior transient response and extremely low power consumption.

Custom-Engineered Transducers

While some manufacturers are content with putting off-the-shelf transducers in their boxes, we custom-design and build ours from scratch. We do this because the transducers (woofers and tweeters) are the part of the system you actually hear, and we want them to sound great. Our loudspeakers deliver truly impressive performance at levels that easily cut through stage clutter, even in the most demanding situations. We make our own because they have to be right—right for each application, and most importantly—right for you!

Speaking of Control...

The F1320D doesn't just sound great, it gives you instant control of your monitor, even mid-performance—something passive monitors simply cannot deliver! Need more volume? Turn the LEVEL dial until the desired volume is reached, getting too much bass or treble? Just reach down and tweak the 3-band EQ (HIGH, MID, LOW) to tailor a rich, exciting sound. We've even provided the first line of defense against feedback, a dedicated FREQUENCY dial you can adjust to eliminate troublesome mic squeals. Total control is always right at your fingertips with the EUROLIVE F1320D.

Instant PA System

You can set up an instant sound system with just one F1320D and a microphone or MP3 player. Thanks to the built-in preamp, you can connect a dynamic mic directly to the F1320D and raise and lower the volume with the Level control. Fast and easy to set up, you can be ready for "show-time" at a moment's notice. There's even a built-in 35-mm socket, so you can mount the F1320D on a standard speaker pole for use as a PA system. And if you need more coverage, chain together as many F1320Ds as you'd like via the convenient XLR or 1/4" TRS LINK OUTPUT connector.

Continued on next page



EUROLIVE F1320D



Versatility

When is a monitor more than a monitor? When it's used as an instrument amplifier. Yes, you read that right; the F1320D can also be used as an onstage amp for keyboards, acoustic guitar, electric violin, etc. You name it—if it's got either a mic or line-level output, you can connect it to the F1320D. Need a keyboard amp and a vocal monitor, but don't have the space on stage for both? Use one of our small-format XENYX mixers to sub-mix the Aux Sends from the main mixer with your keys, all into a single active monitor.

Awesome Sound, Unbelievable Value

The F1320D is the ideal solution for performers/emcees seeking a high-quality active monitor or portable PA system that sets up in a flash. Loaded with a slew of incredible features, but never loaded down by a heavy price tag, the F1320D is an excellent way to expand your current sound system's capabilities without shrinking your wallet. Audition some EUROLIVE F1320Ds at your authorized BEHRINGER dealer today. Then ask them to join the band.

PA System with Active Floor Monitors

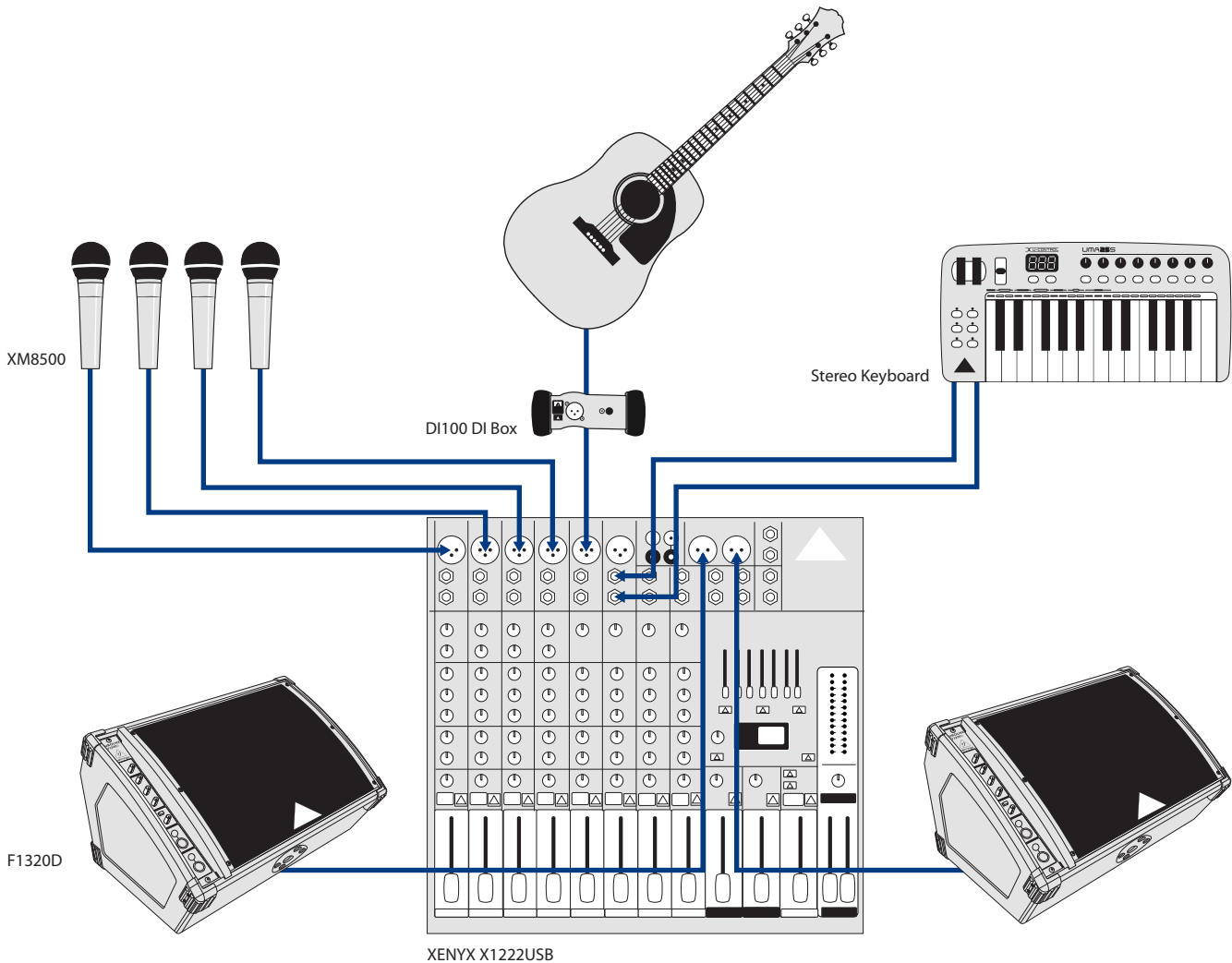

EUROLIVE F1320D

Live Setup with Two Keyboards

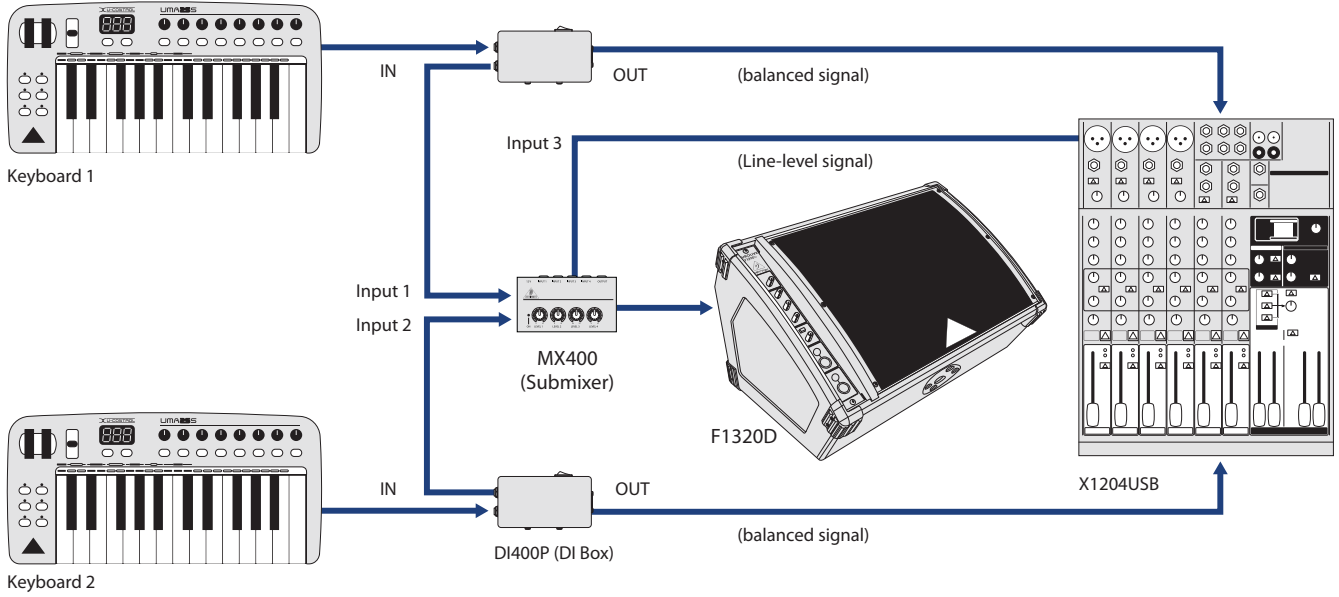

With Dynamic Microphone

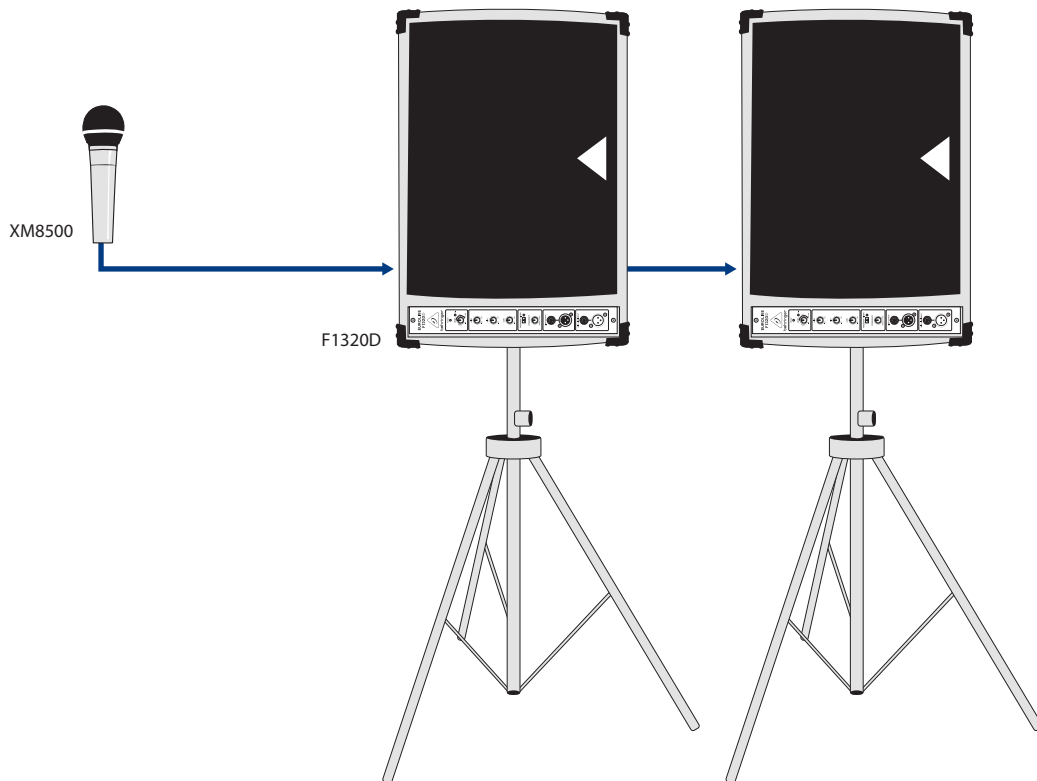

EUROLIVE F1320D

SPECIFICATIONS

Output power

RMS @ 1% THD 180 W / 8 Ω

Peak power 300 W / 8 Ω

INPUT

XLR connector (servo-balanced)

Sensitivity -50 dBu to +10 dBu

Input impedance 11 k Ω balanced;
30 k Ω Unbalanced

¼" TRS jack (servo-balanced)

Sensitivity -50 dBu to +10 dBu

Input impedance 11 k Ω balanced;
30 k Ω unbalanced

LINK OUTPUT

XLR connector

LOUDSPEAKER SYSTEM DATA

Frequency response 60 Hz to 18 kHz
(+2/-4dB Tolerance)

Maximum sound pressure level 121 dB @ 1 m

Limiter optical

EQUALIZER

LOW 80 Hz / +/- 15 dB

MID 2.5 kHz / +/- 15 dB

HIGH 12 kHz / +/- 15 dB

FEEDBACK FILTER

Filter frequency 300 Hz to 6 kHz

Level reduction max. 15 dB

POWER SUPPLY

Power consumption max. 300 W

MAINS VOLTAGE / FUSE

100 - 240 V~ (50/60 Hz) T 2.5 A H 250 V

Mains connector standard IEC receptacle

DIMENSIONS

Dimensions (H x W x D) approx. 14.2 x 22.8 x 16"
approx. 360 x 580 x 406 mm

Weight approx. 39.7 lbs / 18 kg

Please note these specifications are preliminary and conceptual in nature, and as such are subject to change as product development progresses. This information is supplied for market research purposes only and is not to be made public in any manner. This document is solely the property of The MUSIC Group, or one of its subsidiaries, and must be surrendered upon request of the owner.

For service, support or more information contact the BEHRINGER location nearest you:

Europe Tel.: +49 2154 9206 4149
Fax: +49 2154 9206 4199

USA/Canada Tel.: +1 425 672 0816
Fax: +1 425 673 7647

Singapore Tel.: +65 6845 1800
Fax: +65 6214 0275

Australia Tel.: +61 03 9877 7170
Fax: +61 03 9877 7870

Japan Tel.: +81 3 5281 1180
Fax: +81 3 5281 1181

©2010 Red Chip Company Ltd. Technical specifications and appearance subject to change without notice. The information contained herein is correct at the time of printing. All trademarks are the property of their respective owners. BEHRINGER accepts no liability for any loss which may be suffered by any person who relies either wholly or in part upon any description, photograph or statement contained herein. 985-10000-00478

behringer.com

