

SOURCE FOUR^{jr}TM
SOURCE FOUR^{jr}TM Zoom
UL/cUL Assembly Guide

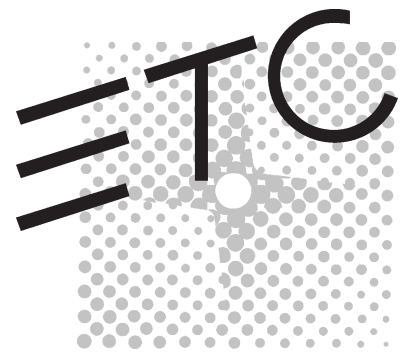

SOURCE FOURjr™ and SOURCE FOURjr™ Zoom

Assembly Guide

Contents

Lamp socket assembly	5
Lens holder assembly	9
Maintenance	11
Shutter assembly	13
Final assembly	15

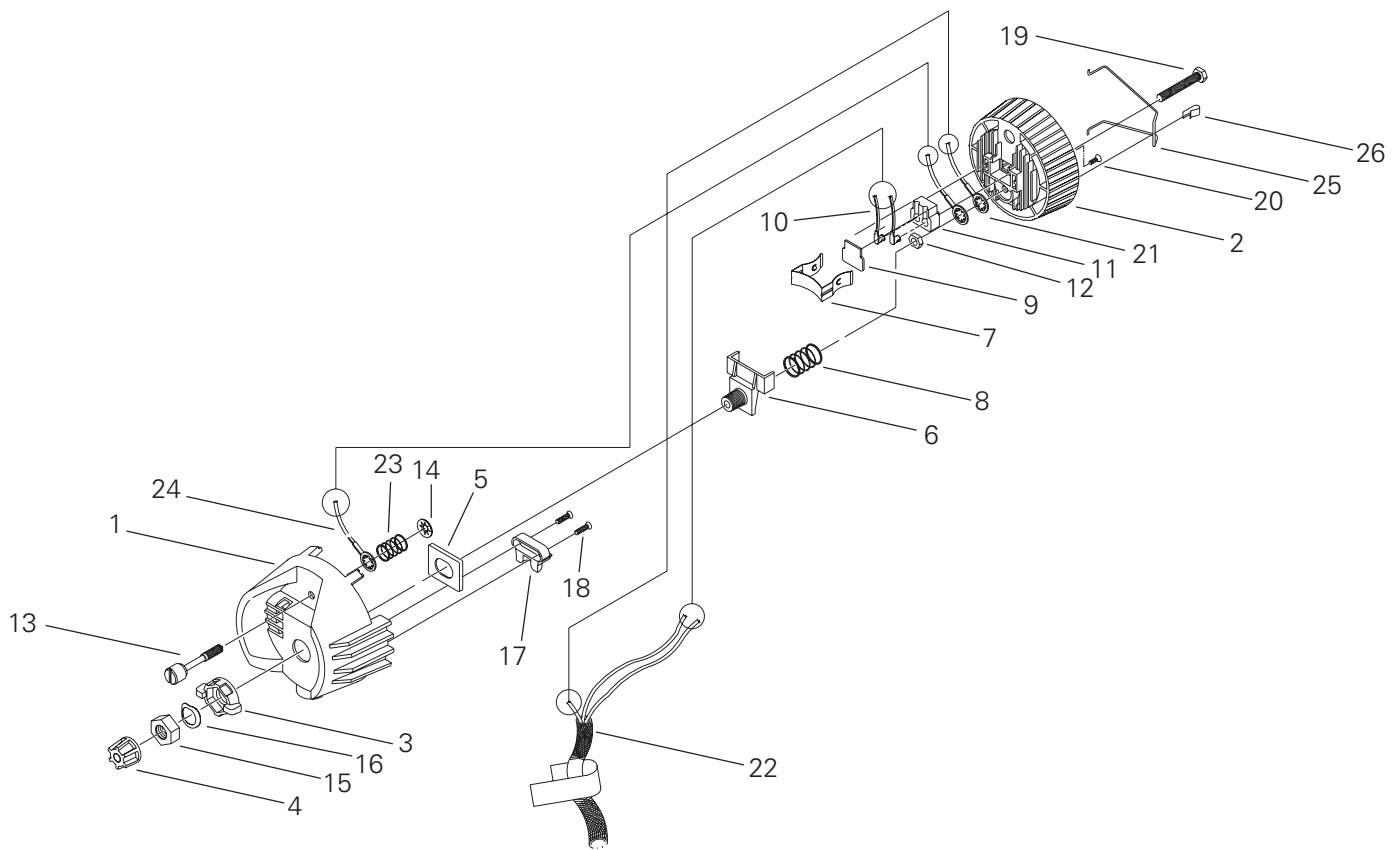

Lamp socket assembly

Reference number	Part number	Description	Quantity required
1	7060A3055	Housing, socket, casting, painted	1
2	7060A3057	Socket, light baffle casting, painted	1
3	7060A4007	Knob, X-Y, lamp set	1
4	7060A4008-02	Knob, Z, lamp set w/female insert	1
5	7060A4011	Bushing, cup	1
6	7060A3011	Hub, index, casting	1
7	7060A3012	Spring, lamp retainer	1
8	HW748	Spring, compression	1
9-11	M718	Complete TP22 450 degree-C CLCM assembly	1
9	W330-03	TP22 CLCM assembly, mica	(1)
10	W330-04	TP22 CLCM 16-gauge, 1/4" semi-striped, Ni-gold contacts, 600V, 450°C	(2)
11	W330-02	TP22 CLCM assembly, ceramic	(1)
12	HW534	Nut, hex, 1/4-20, black zinc	1
13	7060A3025	Screw, 1/4-20 knurled head	1
14	HW746	Retaining ring, flat, Southco	1
15	HW5123	Nut, hex, 9/16-18, black zinc	1
16	HW747	Washer, wave	1
17	7060A3056	Clamp, strain relief, painted	1
18	HW3103	Screw, 8-32 x 5/8 PhFHMS, black zinc	2
19	HW5122	Bolt, 1/4-20 x 1.75, full thread, black zinc	1
20	HW2125	Screw, self tap, 6-32 x 1/4, black zinc	1
21	7060B7003	48" W420 wire, 16 gauge, 200° C/300V, green, UL 1180/CSA AWM with lug J490T installed	1
22	W689	36" sleeve, fiberglass	1
23	HW749	Spring, ground	1
24	7060B7007	4" W420 wire, 16 gauge, 200° C/300V, green, UL 1180/CSA AWM with two J490T lugs installed	1
25	7060A3085	Lamp retainer wire	1
26	HW8203	Tinnerman clip	1

Lamp socket assembly

Tools required: Open-end adjustable wrench or a 7/16" socket, needle-nose pliers, screwdriver.

Figure 1

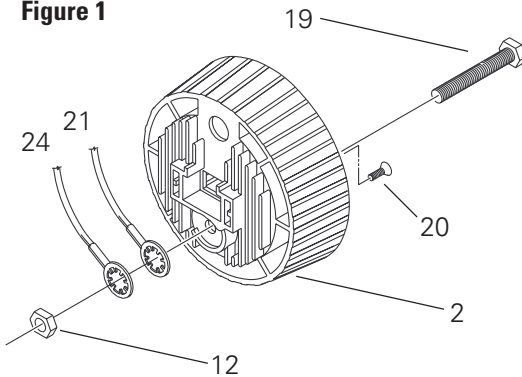

1. Install the screw (20) into the light socket baffle casting as shown in figure 1. (Also see figure 7 on page 7.)

Note: Do not install the screw if the fixture will be used with 77V lamps and ETC's Dimmer Doubler. This screw prevents 77V lamps from being installed.

2. Insert the bolt (19) through the light baffle socket casting (2).
3. Install the green ground wire assemblies (21 and 24) on the bolt (19) with the prongs on the crimped connectors toward the casting. Run both wires through the indent in the lip around the bolt hole. Secure with nut (12) and torque to 60 inch pounds.

Figure 2

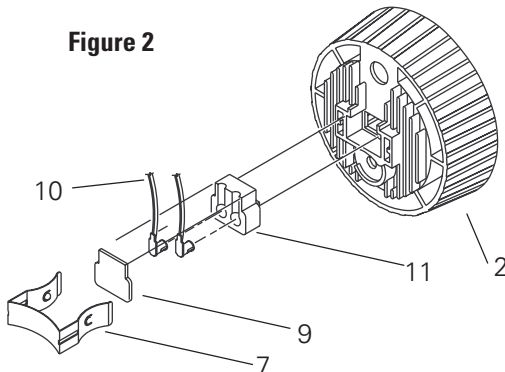

4. Place the ceramic TP22 socket (11) into the light baffle socket casting (2) as shown in figure 2. Be sure it is well seated. Firmly push the connectors on the white TP22 leads (10) into the grooves in the socket.
5. Place the TP22 mica (9) over the leads, then install the lamp retainer spring (7). The lamp retainer spring secures the mica. Insert the spring one end at a time, making sure the rectangular slot in each side of the spring seats on the corresponding tab in the casting.

Important: If the spring does not seat correctly, coax it into place with a screwdriver or needle-nose pliers.

Figure 3

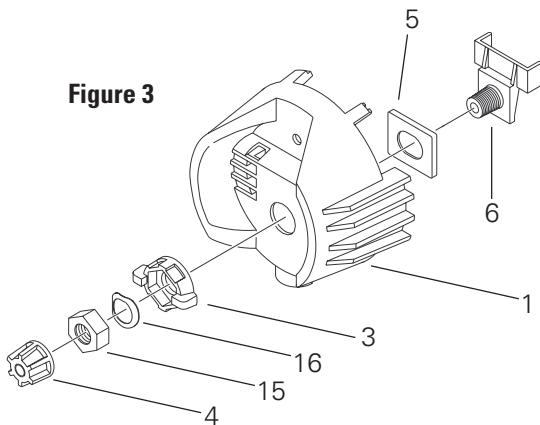

6. Install the bushing cup (5) into the housing socket casting (1) as shown in figure 3. The cup should slide smoothly up and down, but not side to side.
7. Insert the threaded end of the index hub (6) through the holes in the bushing cup and the back of the housing socket casting (1).
8. Slide the X-Y knob (3) over the exposed index hub bolt (6), then insert the wave washer (16) on the bolt and secure with the 9/16 hex nut (15). Hand tighten the X-Y knob (3).

Note: Install the wave washer with the upward curve toward the hex nut.

Figure 4

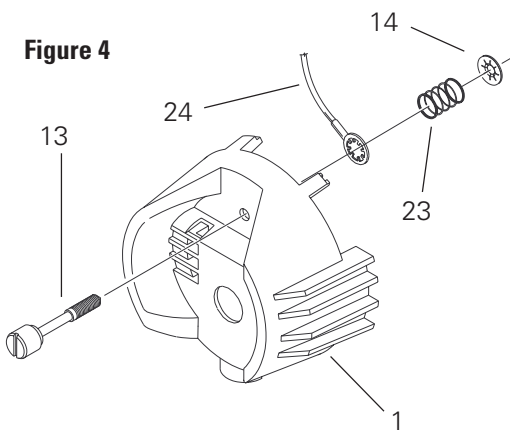

9. Insert the knurled head screw (13) through the housing socket casting (1) as shown in figure 4.
10. Install the shorter green ground wire (24) with the prongs on the crimped connector toward the casting onto the screw.
11. Install the ground spring (23) onto the screw and secure it with the Southco flat retaining ring (14). Install the Southco ring with its prongs away from the casting.

Note: Use pliers to straighten the Southco retaining ring (14) if it bends when you install it on the bolt.

Figure 5

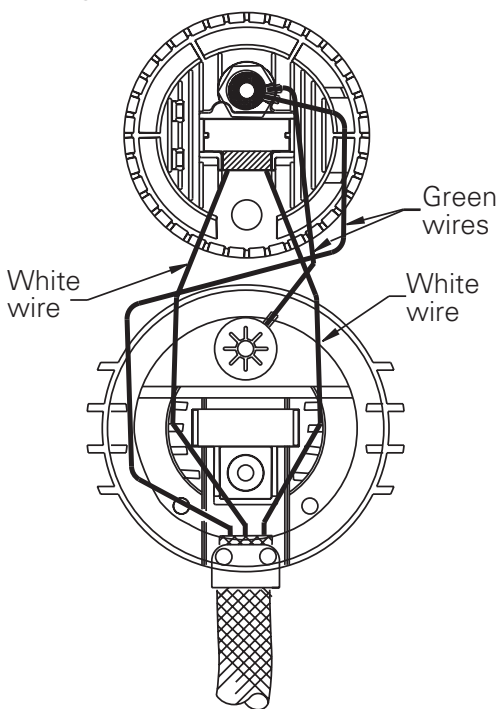

12. Lay the leads in the bottom half of the cable clamp, making sure that the fiberglass sleeving extends slightly past the screw holes in the housing socket casting. Install new sleeving if necessary. Then, route the wires as shown in figure 5.

Important: You must follow the wire routing diagram to ensure that the socket leads do not interfere with the lamp focus mechanism.

13. Install the top half of the cable clamp (17) and secure it with the two screws (18) as shown in figure 6. Tighten the screws alternately to ensure a solid connection.

Note: To ensure that the clamp holds the cable tightly, flatten the cable, then fold over the sleeving before you install the top half of the clamp. Make sure the top edge of the cable clamp is even with the edge of the socket to prevent interference with lamp focus movement. Make sure sleeving is not pinched.

Figure 6

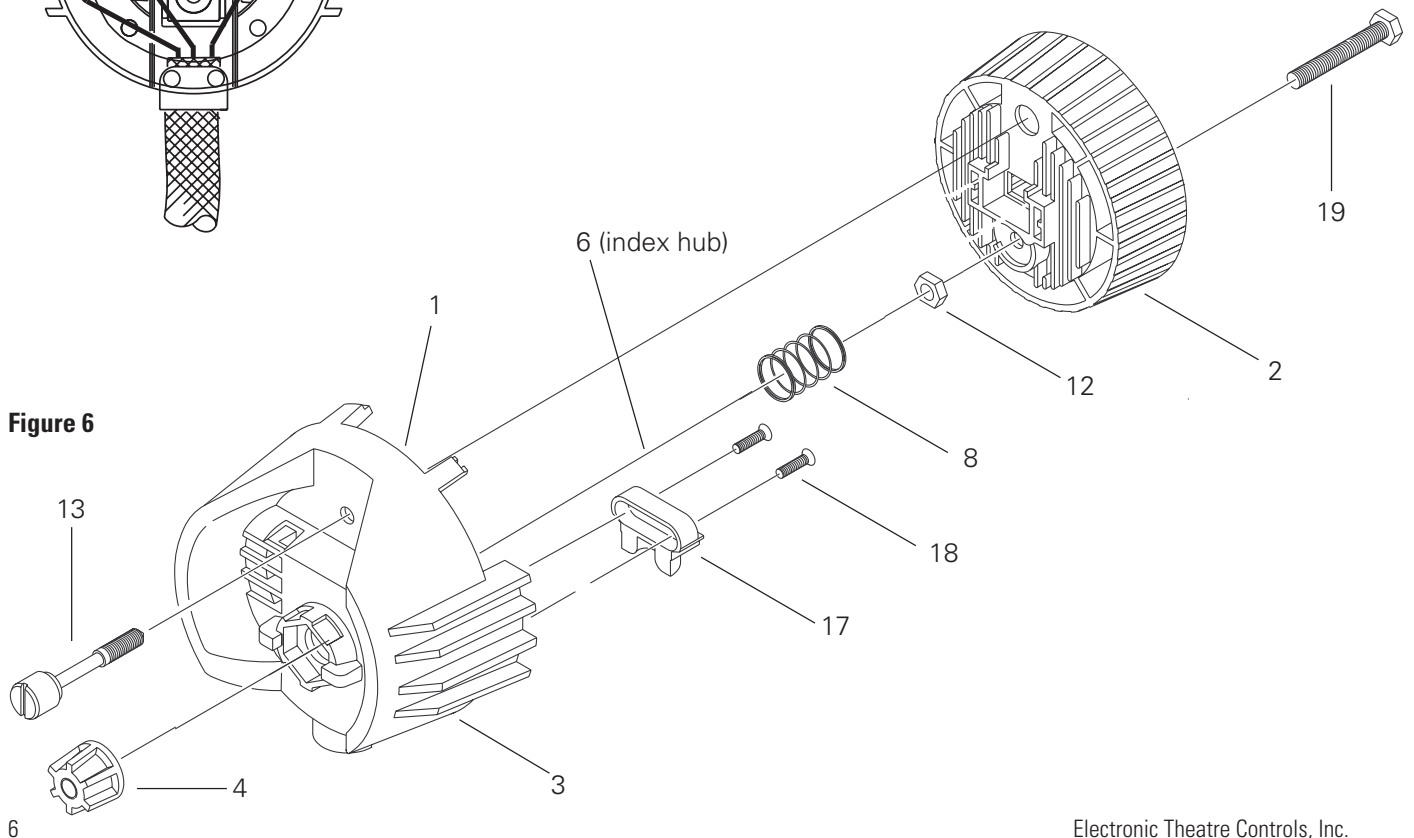

14. Place the spring (8) on the protrusion on the inside of the index hub (6).
15. Insert bolt (19) through the light socket baffle (2), thread nut (12), through spring (8) and through the index hub (6) of the housing socket (1), joining the two castings. Make sure wires are not pinched between the two pieces.
16. Before proceeding, check again to make sure the wires are still positioned as indicated in figure 5. Adjust if necessary.
17. Press the two castings together firmly so the bottom of the light baffle (2) sits on top of the cable clamp (17), then install the X-Y lampset (3) and Z lamp knob (4). Hand tighten the knob all the way to the right.

Important: You must install Z knob as described above to ensure proper lamp focus travel.

18. Set the crossbar of the retainer clip (25) under the two hooks on the clip bracket as shown in figure 7.
19. Place the Tinnerman clip (26) over the retainer clip crossbar between the two hooks and press it down firmly until it snaps into place.

Figure 7

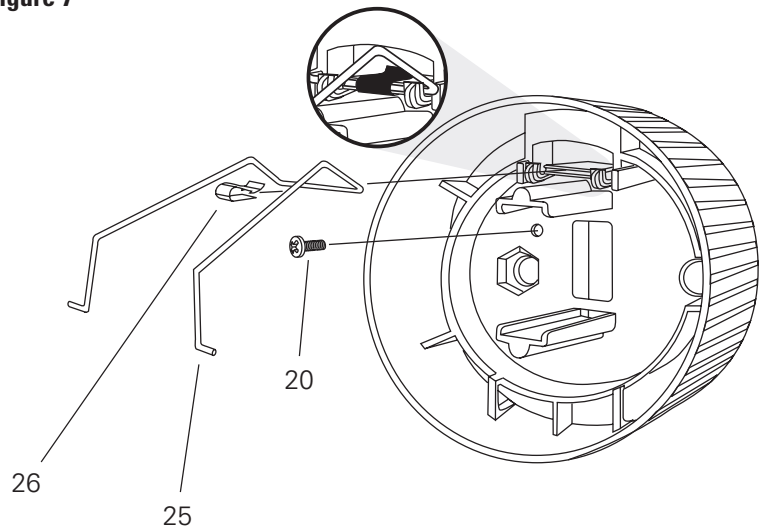

Lens holder assembly

Reference number	Part number	Description	Quantity required
1	7062A3005	Lens holder, 26°	1
2	7062A3017	Lens holder, 36°	1
3	7062A3018	Lens holder, 50°	1
4	7062A3019	Lens holder, Zoom, forward	1
5	7062A3020	Lens holder, Zoom, back	1
6	7062A4001	Lens, 26°, "black dot"	1
7	7062A4002	Lens, 36°, "white dot"	1
8	7062A4003	Lens, 50°, "yellow dot"	1
9	7062A4008	Lens, Zoom, forward	1
10	7062A4009	Lens, Zoom, back, black	1
11	7062A3027	Lens cover, Zoom, front, 25°-50°	1
12	7062A3026	Lens cover, Zoom, rear, 25°-50° (mounted on rear side of lens holder)	1
13	7062A3029	Plate, secondary aperture	1
14	HW124	Scre 4-40 x 1/4 SPHMS, black Oxide	2
15	HW196	Nut 4-40 Keps	4
16	HW1127	Spacer	2
17	7060A4010	Bushing gate fixed lens rear lens front lens	4 4 4
18	HW8209	Tinnerman clip	3
19	HW4117	Nylon washer, flat, #10	1 or 2
20	HW779	Spring, compression	1 or 2
21	HW8201	Lens knob, 10-32 x .50 LG male stud, black Zoom Fixed field angle	2 1
	7062A2001	Lens holder assembly, 26° (black)	1
	7062A2003	Lens holder assembly, 36° (white)	1
	7062A2004	Lens holder assembly, 50° (yellow)	1
	7062A2005	Lens holder assembly, Zoom, forward	1
	7062A2006	Lens holder assembly, Zoom, back	1

Lens Holder Assembly

Fixed Field Angle Lens

1. Position the lens by centering the point dot between the three tabs, as shown below in figure 8.
2. Center one Tinnerman clip (18) on each tab, and press clip until it is fully seated. If clips are in uneven positions, lens will be tilted or loose.
3. Firmly press each clip down and roll it away from the center of the lens to ensure contact on lens surface.
4. Check lens and make sure the clips hold it securely.
5. Snap on the bushings (17).

Figure 8

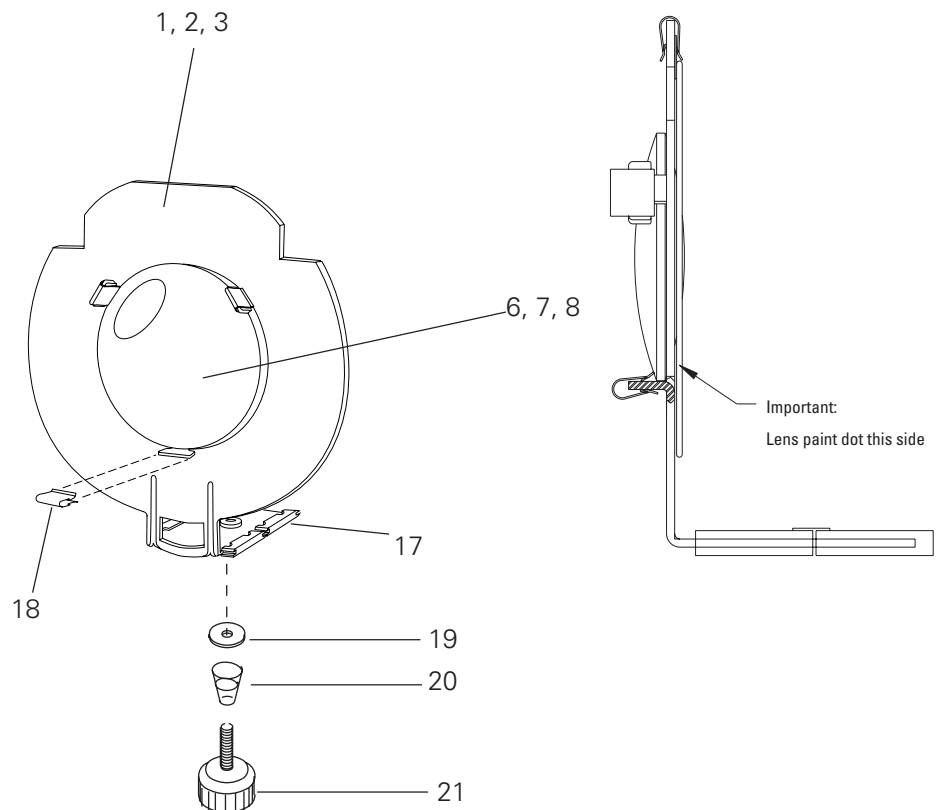

Zoom Front Lens Assembly

1. Position the lens (9) between the lens holder (4) and the lens cover (11) so that the convex side of the lens faces the lens holder, as shown in Figure 9 below.
2. Align the holes in the lens cover with the holes in the lens holder as shown below.
3. Secure the lens cover and the lens to the lens holder using screws (14) and locking nuts (15). Tighten securely to ensure no lens movement.
4. Snap the bushings (17) onto the lens holder assembly as shown.

Figure 9

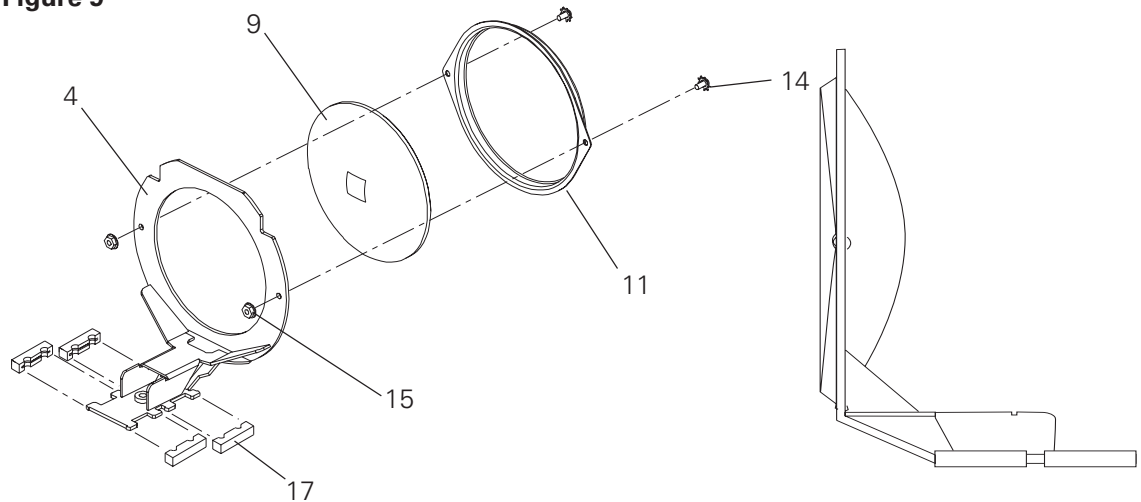

Zoom Rear Lens Assembly

1. Slide spacers (16) over the PEM studs of the secondary aperture plate (13), as shown in Figure 10 below.
2. Insert the PEM studs on the secondary aperture plate (13) through the holes in the lens holder (5).
3. Position the lens (10) between the lens holder (5) and lens cover (12) as shown in Figure 10. The blue orientation marks on the lens should face towards the lens holder.
4. Insert the PEM studs of the secondary aperture plate (13) through the lens cover (12).
5. Secure the lens cover, lens, and aperture plate using nuts (15).
6. Snap bushings (17) to the lens holder (5).

Figure 10

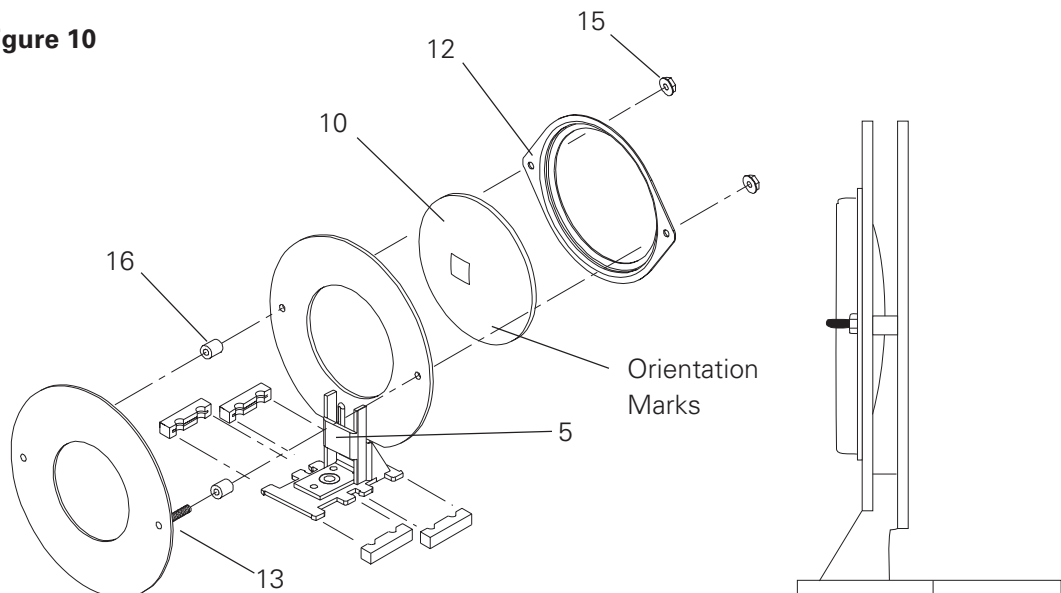

Maintenance

Cleaning lenses

1. Dampen a clean, lint-free cloth with vinegar or household ammonia. You may use water, but it will leave spots which may be removed by polishing the lens gently with a clean, dry cloth.

Warning: Never use glass and window cleaner or any abrasive material to clean the lens. Glass and window cleaners will stain the lens surface. Abrasive materials (such as steel wool) will damage the surface of the lens.

2. Starting from the center, gently wipe the lens.

Cleaning the reflector

Remove dust with a blast of oil-free air or wipe with a clean, lint-free cloth using alcohol or distilled water (alcohol is recommended).

Warning: Do not use glass and window cleaners on the reflector. Chemicals in these cleaners will stain the reflector.

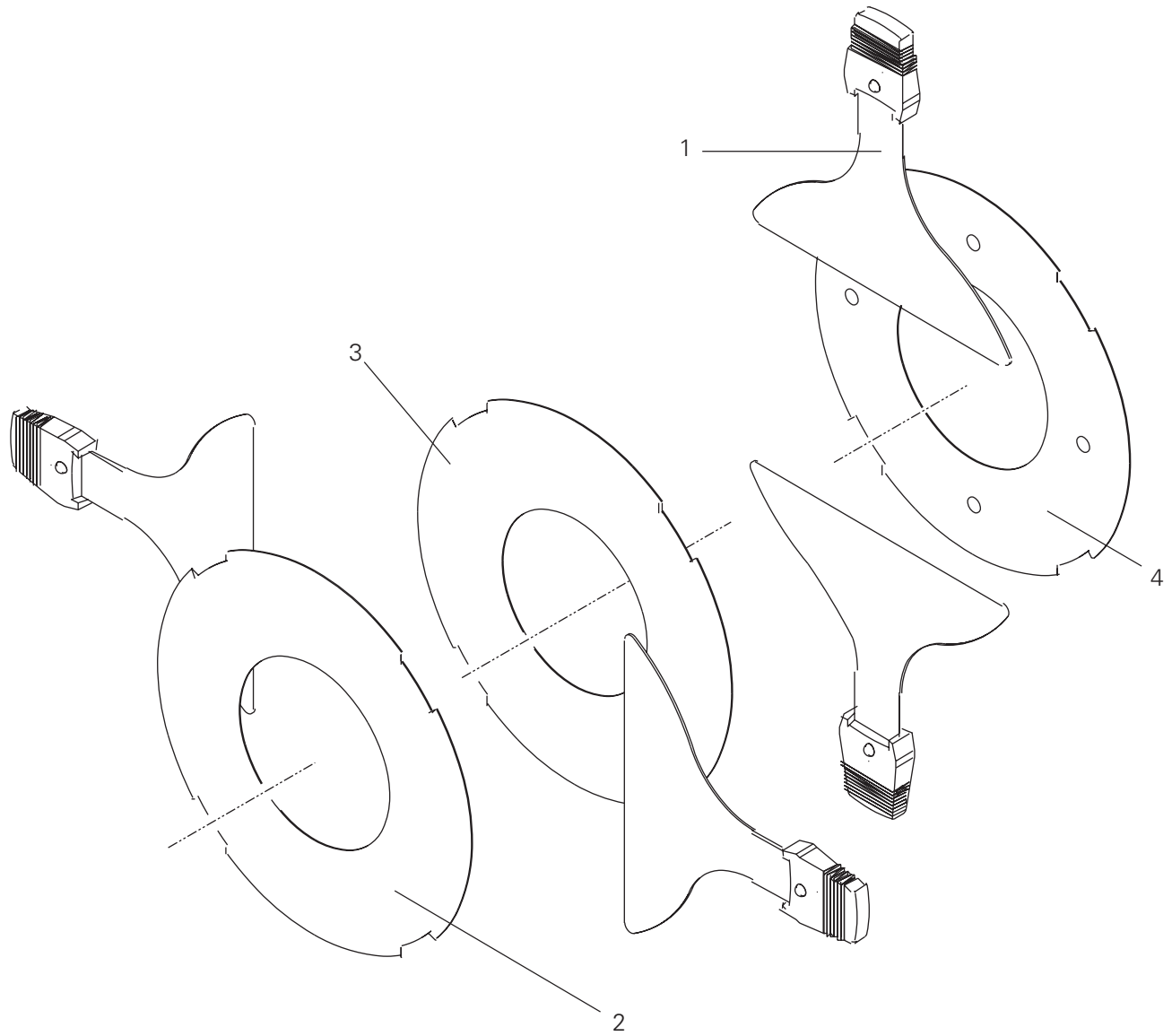

Shutter assembly

Reference number	Part number	Description	Quantity required
1	7062A2002	Shutter blade assembly	4
2	7062A3016	Plate, divider	1
3	7062A3010	Plate, gate (middle)	1
4	7062A3030	Plate, divider with dimples	1
5	7062A3031	Plate, support, spring (see figure 12)	1
6	HW754	Spring, shutter (see figure 12)	4

Shutter assembly

Tools required: None

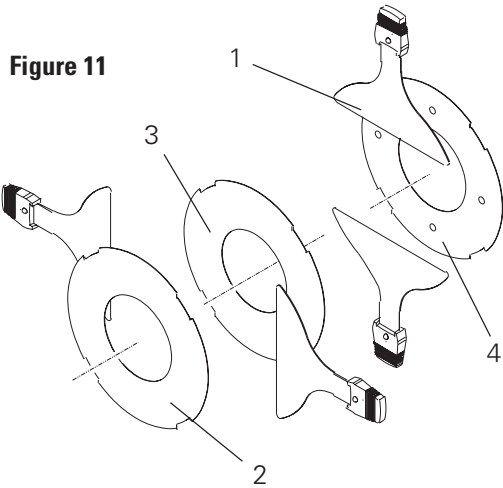

Figure 11

1. Place the bottom divider plate (2) on a flat surface.
Note: The notches on the divider plates must line up with each other.
Warning: Divider plate edges are sharp. Handle with caution!
2. Place two shutter blades (1) on top of plate (2), handles facing outward.
Note: Install shutter blades with the rounded sides facing the same direction.
3. Place the middle divider plate (3) on top of the two shutter blades.
4. Place the two remaining shutter blades (1) on top of the middle divider plate.
Note: The third and fourth shutter blades should be at 90° angles to the first and second.
5. Place the top divider plate (4) on top of the third and fourth shutter blades.
6. Install the four springs (6) onto the nips on the spring plate support (5).
7. Place the dimples of the plate divider (4) onto the open ends of the springs.

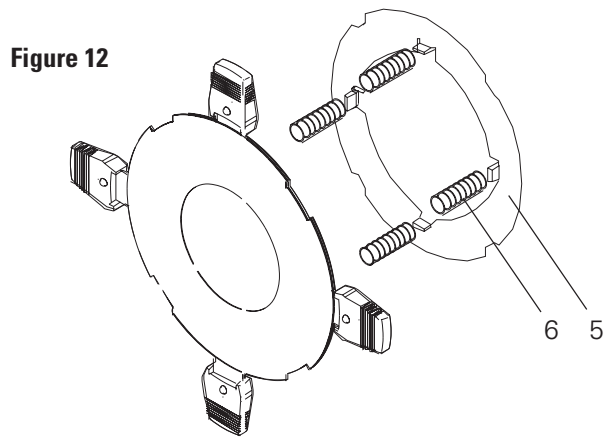
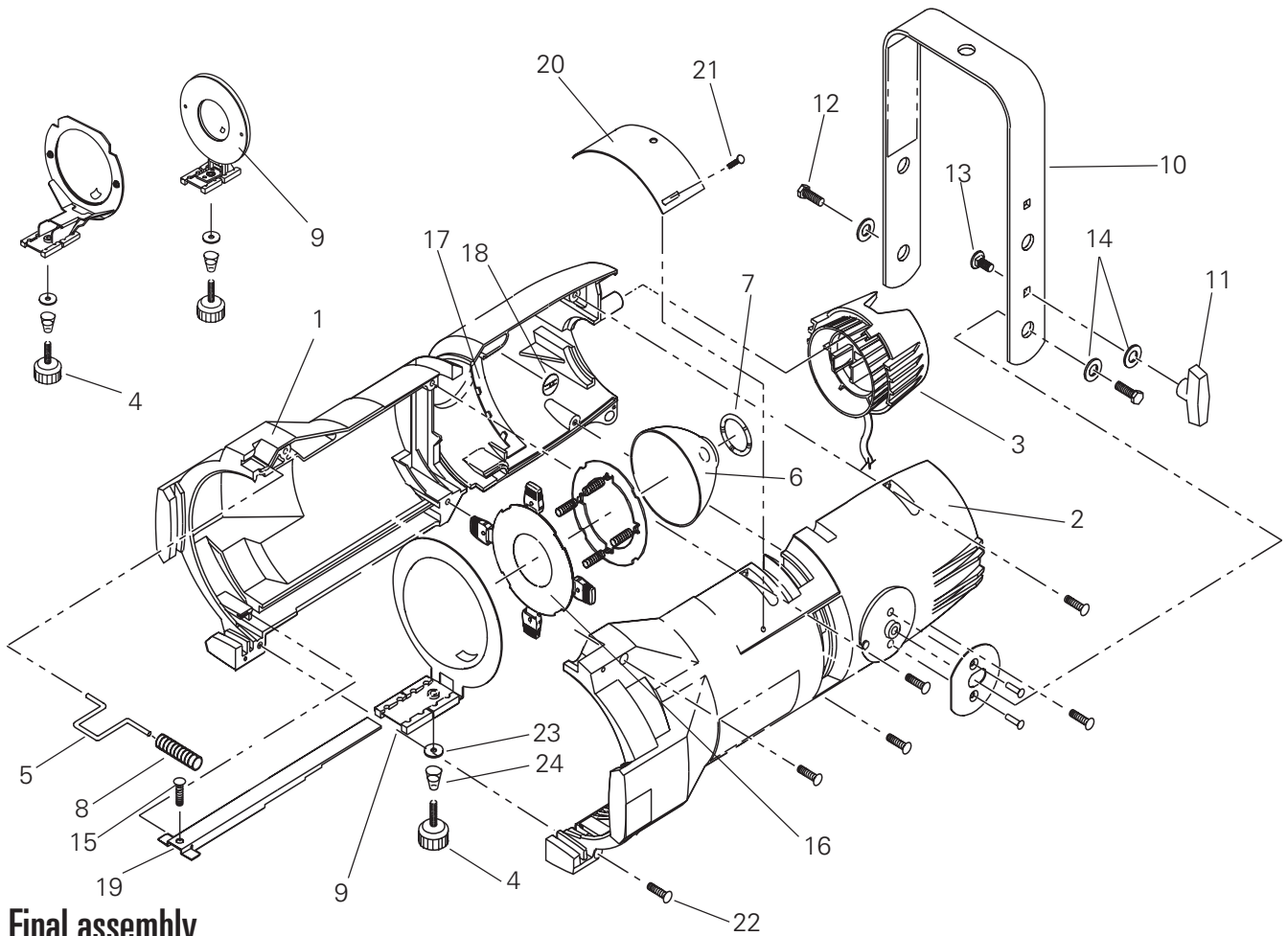

Figure 12



Final assembly

Reference number	Part number	Description	Quantity required
1	7062A3002	Barrel, left casting	1
2	7062A3004	Barrel, right casting	1
3	7062A2008	Lamp burner assembly	1
4	HW8201	Knob, 10-32X.50LG male stud, black	1 or 2
5	7061A3005	Retainer, gel clip	1
6	7062A4010	Reflector, jr, glass	1
7	7062A3007	Spring, round	1
8	HW750	Spring, gel retainer	1
9	See page 8	Lens holder assembly	1 or 2
10	7062A3009	Yoke, jr	1
11	HW8144	Handle, yoke knob, 3092, 5/16-18, female	1
12	HW5193	Bolt, hex 5/16-18 x 1.0" black oxide (yoke)	2
13	HW5125	Bolt, carriage 5/16-18	1
14	HW5126	Washer, flat, 5/16, black oxide (yoke)	3
15	HW391	Screw, PHMS, 8-32 X 3/4 LG.	1
16	See page 10	Shutter assembly	1
17	7062A3013	Spring, reflector support	2
18	HW8200	Retainer, push on	2
19	7062A3014	Light baffle strip	1
20	7062A3015	Cover, iris slot	1
21	HW372	Screw, PhPHMS, 8-32 X 1/4 black oxide	2
22	HW369	Screw, PhPHMS, 8-32 X 5/8 black oxide	6
23	HW4117	Nylon, washer flat, #10	1 or 2
24	HW779	Spring compression	1 or 2

Final assembly

Note: *Left and right designations are your left and rights as you look at the front (gel plane) of the unit.*

Tools required: Phillips head screwdriver.

1. Place the left barrel casting (1) face up on your work surface with the colorframe end to your right.
2. If necessary, place spring (17) over post in right and left castings (1 and 2). Secure with clip (18).
3. Set shutter assembly into the shutter slot in left casting (1) with the rounded side of the shutter handles facing right.
4. Install the short end of the gel retainer clip (5) in the left lens holder casting (1).
5. Position clip (5) in the forward, locked position, then install the retainer spring (8) on the clip.
6. Snap spring (7) onto reflector (6) and place assembly into left casting (1) so that the front edge of the reflector is supported by spring (17) and the spring (7) on the back rests in the left casting rear supports.
7. Gently set the right barrel casting (2) onto the left casting so that the gel clip retainer, shutter assembly and reflector assembly fit into their respective positions.
8. Starting with the corner nearest the gel clip retainer, attach the right casting to the left casting with screws (22). Do the right screws first, then the middle screws, then the left screws.
9. Install the iris slot cover (20) onto the barrel assembly with screws (21).
10. With the colored dot on the lens facing out the barrel, slide the lens holder assembly (or assemblies, if Zoom) into the lens holder track inside the barrel. The assembly should slide smoothly in the track.
11. Insert light baffle strip (19) through front of barrel assembly and through hole in lens holder assembly. Slide strip (19) through supports in front of fixture and install screw (15), spring (24), washer (23), and knob (4).
12. Attach the lamp burner (3) to the barrel assembly with the knurled head screw.
13. Attach yoke (10) to barrel assembly with bolts (12) and washers (14). Attach yoke knob (11) with bolt (13) and washer (14). Tighten bolts (12) to secure yoke to fixture.



Electronic Theatre Controls

North America

3030 Laura Lane
Middleton, Wisconsin 53562 • USA
Tel: (+1) 608 831 4116 • Fax: (+1) 608 836 1736

Europe

5 Victoria Industrial Estate • Victoria Road
London W3 6UU • England
Tel: (+44) 181 896 1000 • Fax: (+44) 181 896 2000

Asia

Room 605-606 • Tower III • Enterprise Square
9 Sheung Yuet Road • Kowloon Bay • Hong Kong
Tel: (+852) 2799 1220 • Fax: (+852) 2799 9325

World Wide Web <http://www.etconnect.com> • **Email** mail@etconnect.com

Copyright 1999. Specifications subject to change. Source Four jr™ and Source Four jr™ Zoom are protected by US patent numbers 5,268,613 and 5,446,637. International patents pending.

Revised 9/99. 7062M1006

This document is the confidential property of ETC and is loaned subject to return upon demand. Title to this document is never sold or transferred for any reason. This document is to be used only pursuant to written license or written instructions of ETC. All rights to designs and inventions are reserved by ETC. Possession of this document is subject to the foregoing.