



**the  
t.bone**

IEM 100  
UHF wireless system

Musikhaus Thomann  
Thomann GmbH  
Hans-Thomann-Straße 1  
96138 Burgebrach  
Germany  
Telephone: +49 (0) 9546 9223-0  
E-mail: [info@thomann.de](mailto:info@thomann.de)  
Internet: [www.thomann.de](http://www.thomann.de)

18.06.2018, ID: 269815

# Table of contents

<b>1</b>	<b>General notes</b> .....	<b>5</b>
<b>2</b>	<b>Safety instructions</b> .....	<b>7</b>
<b>3</b>	<b>Features and scope of delivery</b> .....	<b>11</b>
<b>4</b>	<b>Installation and starting up</b> .....	<b>15</b>
	4.1 General information.....	15
	4.2 Transmitter.....	17
	4.3 Receiver.....	20
	4.4 Taking the system into operation.....	21
<b>5</b>	<b>Components and functions</b> .....	<b>22</b>
	5.1 Transmitter.....	22
	5.2 Receiver.....	27
<b>6</b>	<b>Operating</b> .....	<b>32</b>
	6.1 Setting up the transmitter.....	32
	6.2 Setting up the receiver.....	35
<b>7</b>	<b>Troubleshooting</b> .....	<b>38</b>

<b>8</b>	<b>Technical specifications.....</b>	<b>41</b>
8.1	Transmitter.....	41
8.2	Receiver.....	42
8.3	Frequency charts.....	43
<b>9</b>	<b>Protecting the environment.....</b>	<b>54</b>

# 1 General notes

This user manual contains important information on safe operation of the device. Read and follow all safety notes and all instructions. Save this manual for future reference. Make sure that it is available to all persons using this device. If you sell the device to other users, be sure that they also receive this manual.

Our products are subject to a process of continuous development. We therefore reserve the right to make changes without notice.

## **Symbols and signal words**

This section provides an overview of the symbols and signal words used in this user manual.

Signal word	Meaning
<b>DANGER!</b>	This combination of symbol and signal word indicates an immediate dangerous situation that will result in death or serious injury if it is not avoided.
<b>CAUTION!</b>	This combination of symbol and signal word indicates a possible dangerous situation that can result in minor injury if it is not avoided.
<b>NOTICE!</b>	This combination of symbol and signal word indicates a possible dangerous situation that can result in material and environmental damage if it is not avoided.
Warning signs	Type of danger
	Warning – danger zone.

## 2 Safety instructions

### Intended use

This device is intended to be used for the wireless transmission of audio signals to earplugs. Use the device only as described in this user manual. Any other use or use under other operating conditions is considered to be improper and may result in personal injury or property damage. No liability will be assumed for damages resulting from improper use.

This device may be used only by persons with sufficient physical, sensorial, and intellectual abilities and having corresponding knowledge and experience. Other persons may use this device only if they are supervised or instructed by a person who is responsible for their safety.

### Safety



#### **DANGER!**

#### **Danger for children**

Ensure that plastic bags, packaging, etc. are disposed of properly and are not within reach of babies and young children. Choking hazard!

Ensure that children do not detach any small parts (e.g. knobs or the like) from the unit. They could swallow the pieces and choke!

Never let children unattended use electrical devices.



### **CAUTION!**

#### **Possible hearing impairment**

The use of earphones at high volume over a longer period of time can cause permanent hearing damage.

Adjust the output volume of your audio device to a medium value and use the earphones no longer than about one hour a day.



### **NOTICE!**

#### **Operating conditions**

This device has been designed for indoor use only. To prevent damage, never expose the device to any liquid or moisture. Avoid direct sunlight, heavy dirt, and strong vibrations.





**NOTICE!**

**External power supply**

The device is powered by an external power supply. Before connecting the external power supply, ensure that the input voltage (AC outlet) matches the voltage rating of the device and that the AC outlet is protected by a residual current circuit breaker. Failure to do so could result in damage to the device and possibly the user.

Unplug the external power supply before electrical storms occur and when the device is unused for long periods of time to reduce the risk of electric shock or fire.



**NOTICE!**

**Risk of fire due to incorrect polarity**

Incorrectly inserted batteries may destroy the device or the batteries.

Ensure that proper polarity is observed when inserting batteries.



**NOTICE!**

**Possible damage by leaking batteries**

Leaking batteries can cause permanent damage to the device.

Take batteries out of the device if it is not going to be used for a longer period.

### **3 Features and scope of delivery**

The UHF wireless system IEM 100 is suitable for use as in-ear monitoring system especially for professional events, on rock stages and concert halls, theatres and musicals.

### **the t.bone IEM 100 770 MHz (item no. 269815)**

Your UHF wireless system IEM 100 consists of the following components:

- 9.5" stereo transmitter IEM 100 ST
  - Very high sensitivity at very high signal-to-noise ratio
  - Input: 2 × XLR/1/4" phone combo socket
  - Headphones outlet (1/4" phone socket) with volume control
  - Mounting option for two transmitters side by side in a 19" rack
  - Operating voltage supply: DC 12 V  $\overline{\text{---}}$
- Bodypack receiver IEM 100 R
  - Earplug outlet (1/8" mini phone socket) with volume control
  - Operating voltage supply: 2 × AA cells (LR6, 1.5 V)
- Earplugs EP 3

Ten systems can be operated simultaneously. The system operates within a frequency range of 768.000 MHz to 787.275 MHz, divided into 10 frequency groups. The frequency range is intended for use in Germany with regard to LTE.

Included accessories: 12V AC adapter, mounting hardware for rack mounting, antenna-converter and plastic case.

**the t.bone IEM 100 800 MHz  
(item no. 137618)**

Your UHF wireless system IEM 100 consists of the following components:

- 9.5" stereo transmitter IEM 100 ST
  - Very high sensitivity at very high signal-to-noise ratio
  - Input: 2 × XLR/1/4" phone combo socket
  - Headphones outlet (1/4" phone socket) with volume control
  - Mounting option for two transmitters side by side in a 19" rack
  - Operating voltage supply: DC 12 V  $\overline{\text{---}}$
- Bodypack receiver IEM 100 R
  - Earplug outlet (1/8" mini phone socket) with volume control
  - Operating voltage supply: 2 × AA cells (LR6, 1.5 V)
- Earplugs EP 3

Ten systems can be operated simultaneously. The system operates within a frequency range of 791.850 MHz to 813.225 MHz, divided into 10 frequency groups.

Included accessories: 12V AC adapter, mounting hardware for rack mounting, antenna-converter and plastic case.

### **the t.bone IEM 100 863 MHz (item no. 137793)**

Your UHF wireless system IEM 100 consists of the following components:

- 9.5" stereo transmitter IEM 100 ST
  - Very high sensitivity at very high signal-to-noise ratio
  - Input: 2 × XLR/1/4" phone combo socket
  - Headphones outlet (1/4" phone socket) with volume control
  - Mounting option for two transmitters side by side in a 19" rack
  - Operating voltage supply: DC 12 V  $\overline{\text{---}}$
- Bodypack receiver IEM 100 R
  - Earplug outlet (1/8" mini phone socket) with volume control
  - Operating voltage supply: 2 × AA cells (LR6, 1.5 V)
- Earplugs EP 3

Three systems can be operated simultaneously. The system operates within a frequency range of 863.1 MHz to 864.4 MHz.

Included accessories: 12V AC adapter, mounting hardware for rack mounting, antenna-converter and plastic case.

## 4 Installation and starting up

### 4.1 General information

Unpack and carefully check that there is no transportation damage before using the unit. Keep the equipment packaging. To fully protect the device against vibration, dust and moisture during transportation or storage use the original packaging or your own packaging material suitable for transport or storage, respectively.

Establish all connections as long as the unit is switched off. Use the shortest possible high-quality cables for all connections.

### Notes on wireless transmission

- This device utilizes frequencies that are not harmonized within the European Union (EU) and therefore may only be used in certain EU member states. In all European countries, the frequencies used for the transmission of audio signals are strictly regulated. Before you start, make sure the frequencies are allowed in the respective country and check whether the operation must be reported to the appropriate authority.  
For more information, please visit: <http://www.thomann.de>.
- Make sure that transmitter and receiver are both tuned to the same channel.
- Never set multiple transmitters to the same channel.
- Make sure that there are no metal objects between the transmitter and receiver.
- Avoid interference from other radio or in-ear systems.



## 4.2 Transmitter

### XLR connections for signal input on the transmitter

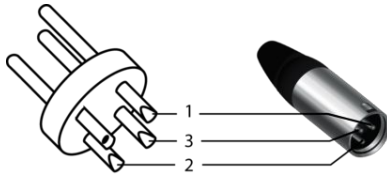

XLR/1/4" combo sockets for signal input on the transmitter. Drawing and table indicate the XLR pin assignment (balanced wiring) as well as the pin assignment of a suitable 1/4" phone plug.

1	Ground, shielding
2	Positive signal (+)
3	Negative signal (-)

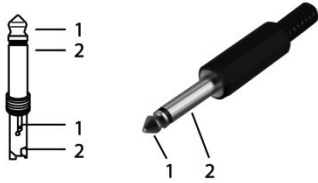

1	Signal
2	Ground, shielding

### Phone socket for headphones outlet



Drawing and table indicate the pin assignment of a 1/4" TRS phone plug to be used.

1	Signal (left)
2	Signal (right)
3	Ground, shielding

### Rack mounting

The unit has been designed for rack mounting in a standard 19-inch rack; it occupies one rack unit.

## Connecting the operating supply voltage



### **NOTICE!**

#### **External power supply**

The device is powered by an external power supply. Before connecting the external power supply, ensure that the input voltage (AC outlet) matches the voltage rating of the device and that the AC outlet is protected by a residual current circuit breaker. Failure to do so could result in damage to the device and possibly the user.

Unplug the external power supply before electrical storms occur and when the device is unused for long periods of time to reduce the risk of electric shock or fire.

First, connect the power adapter to the transmitter and then plug the adapter into a mains wall outlet.

### **Mounting the antenna**

Attach the included antenna to the back of the transmitter. To improve the transmission quality and for adaptation to the specific spatial conditions the antenna can be rotated and swivelled.

If there is not enough space for the direct mounting of the antenna on the unit, e.g. due to limited space in the rack, you can use the supplied coaxial cable to mount the antenna apart from the unit. Therefore use the BNC adapter.

### **Putting the audio connection into operation**

Connect the audio inputs of the transmitter to suitable line outputs of your mixing console or amplifier. Slide the level adjustment switch (11) to the '-12 dB' position. Set the input sensitivity control (2) to a middle position first.

To achieve best sound quality, a fine adjustment of this control may be required. If the input level is too low slide the level adjustment switch (11) to the '0 dB' position.

## **4.3 Receiver**

### **Inserting batteries into the receiver**

Press on the snap-in locks at the side to open the battery compartment (18). Flip the lid open and insert the batteries respecting the correct polarity. Close the battery compartment and switch the transmitter on. The 'RF' LED (22) briefly lights up.

## 4.4 Taking the system into operation

- Make sure that the receiver is switched off, the main switch (14) is set to the 'OFF' position.
- Attach the receiver with the clip to your belt or guitar strap.
- Insert the earplugs into the ear canal carefully and observe the markings 'L' and 'R' for left and right sides.
- Turn the transmitter and the receiver on and test the transmission. Make sure that both transmitter and receiver are set to the same frequency group and the same channel. If necessary, adjust the volume on the receiver, the input sensitivity of the transmitter and the levels on your mixer or amp.

## 5 Components and functions

### 5.1 Transmitter

#### Front panel of the transmitter

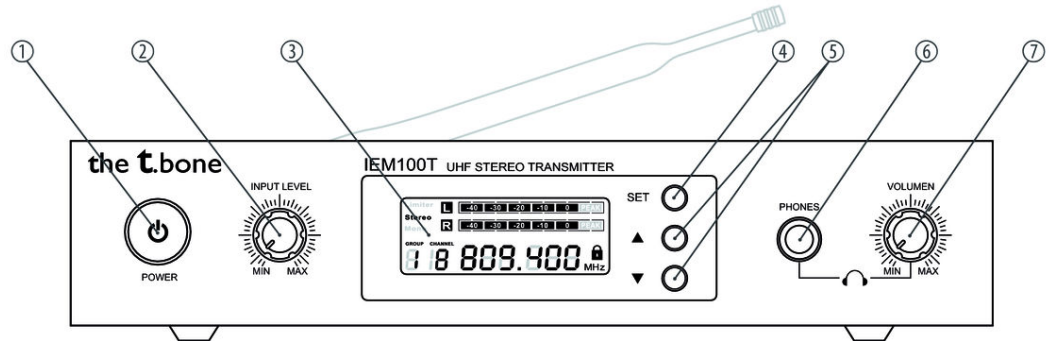

1	<b>POWER</b> Main switch to turn the device on or off. For turning on, keep this button pressed for one second.
2	<b>INPUT LEVEL</b> Control for adjusting the input sensitivity.
3	Display
4	<b>SET</b> Enter button for menu control.
5	▲ / ▼ Buttons for increasing / decreasing the currently indicated value.
6	<b>PHONES</b> Headphones socket.
7	<b>VOLUME</b> Headphones volume control.

## Rear panel of the transmitter

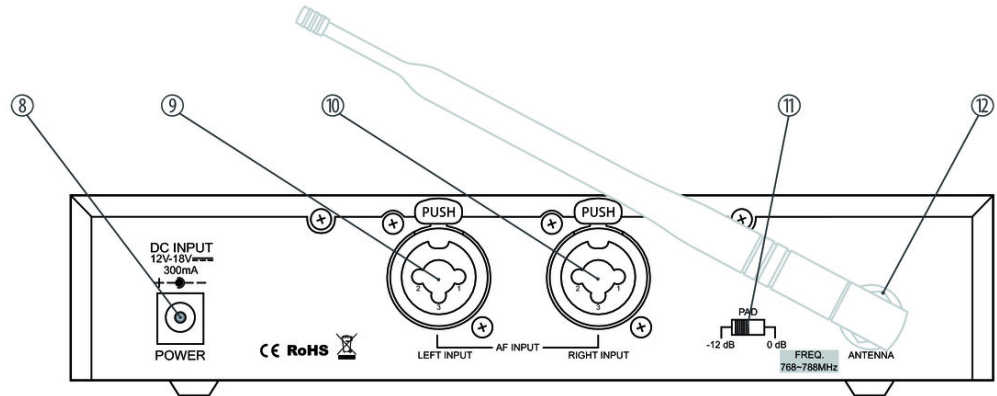



8	<p><b>DC INPUT</b></p> <p>Connect the cable of the supplied mains adapter to this socket. If using another power adapter make sure it provides the correct voltage, plug polarity and sufficient power.</p>
9, 10	<p><b>LEFT INPUT / RIGHT INPUT</b></p> <p>XLR/1/4" combo sockets (left and right channel) for the direct connection to a mixing console or another audio device that is used as signal source.</p>
11	<p><b>PAD</b></p> <p>Level adjustment switch. Set this switch to the '-12 dB' position to attenuate the input signals by 12 dB. In '0 dB' position, there is no attenuation.</p> <p>Beneath, you find the indication of the frequency range, in which the unit operates. The specification here must match the specification on the rear side of the receiver.</p>
12	<p><b>ANTENNA</b></p> <p>BNC mounting socket for the supplied UHF antenna. Make sure the frequency indicated on the antenna matches the frequency range indicated on the transmitter.</p>

## Display of the transmitter

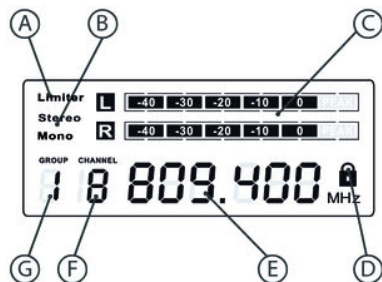

A	<b>Limiter</b> Indicates limiter action as protection against volume peaks.
B	<b>Stereo/Mono</b> Indicates the selected operating mode (stereo or mono).
C	Level indicator for left and right channel.
D	<b>🔒</b> Indicates that the unit is locked to prevent unintentional operation.
E	Indicates the frequency that is assigned to the set combination of frequency group and channel ( ↪ <i>Chapter 8.3 'Frequency charts' on page 43</i> ).
F	<b>CHANNEL</b> Shows the selected channel.
G	<b>GROUP</b> Shows the selected frequency group.

## 5.2 Receiver

### Front panel of the receiver

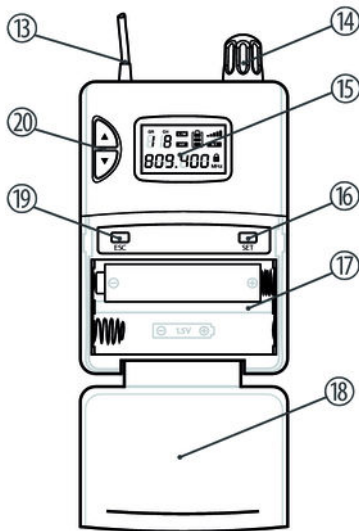

13 Flexible antenna.

14 **ON/OFF/MAX**

Main switch and volume control. Turn this knob clockwise past the point of resistance to turn on the receiver. Turn it further to increase the volume.

Turn this knob counter-clockwise to reduce the volume. Turn it further past the point of resistance to turn off the receiver.

15 Display

16 **SET**

Enter button for menu control.

17 Battery compartment for two AA cells (LR6), 1.5 V or comparable rechargeable batteries.

18 Battery compartment lid.

19 **ESC**  
Function „Cancel/EXIT“ in the menu.

20 **▲ / ▼**  
Buttons for increasing / decreasing the currently indicated value. The balance is regulated by pressing and holding the suitable key.

## Top panel of the receiver

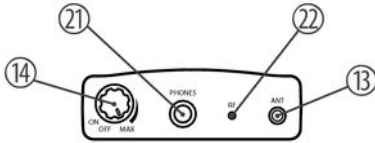

21 **PHONES**  
1/8" mini phone socket (stereo) for the earplugs.

22 **RF**  
This LED lights up on incoming radio signal.

**Rear panel of the receiver**

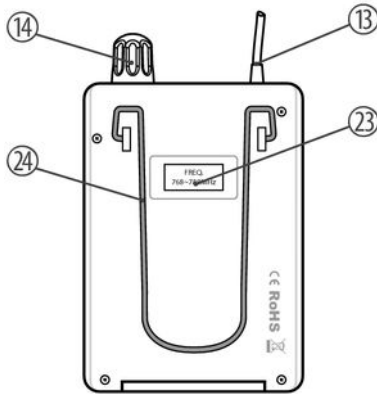

23 Indication of the frequency range in which the device operates. The specification here must match the specification printed on the back of the transmitter.

24 Clip to attach the transmitter to your belt or guitar strap.

## Display of the receiver



H	<b>GR</b> Indicates the selected frequency group.
I	<b>CH</b> Indicates the selected channel.
J	<b>LIM</b> Indicates Limiter action as protection against volume peaks.
K	<b>HF</b> Indicates the activated high frequency boost function.
L	Battery level indicator. Replace the batteries when only one bar remains displayed.
M	Radio signal strength indicator (one to five bars).
N	<b>ST</b> Indicates an incoming stereo signal.

O 	Indicates that the unit is locked to prevent unintentional operation.
P	Indicates the frequency that is assigned to the set combination of frequency group and channel ( ↪ <i>Chapter 8.3 'Frequency charts' on page 43</i> ).

## 6 Operating

### 6.1 Setting up the transmitter

#### Selecting frequency group and channel



Press the *[SET]* button repeatedly until the 'GROUP' field (frequency group) flashes in the display. Use the ▲ or ▼ buttons to increase or decrease the indicated value by one. When the desired value is shown press the *[SET]* button to confirm the setting and proceed to the next menu item.

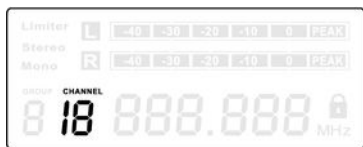

Press the *[SET]* button repeatedly until the 'CHANNEL' field flashes in the display. Use the ▲ or ▼ buttons to increase or decrease the indicated value by one. When the desired value is shown press the *[SET]* button to confirm the setting and proceed to the next menu item.

In the lower right area, the display shows the used transmission frequency in MHz, that is assigned to the set combination of frequency group and channel ( ↪ *Chapter 8.3 'Frequency charts' on page 43*).





*Transmitter and receiver must be set to the same combination of frequency group and channel. If you use multiple wireless systems from this device family, for best results you should assign all systems to the same frequency group, but give each system a different channel.*



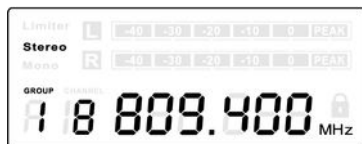

## Selecting the operating mode



Press the *[SET]* button repeatedly until the 'Stereo' or 'Mono' field flashes in the display. Use the ▲ or ▼ buttons to toggle between mono and stereo operation. When the desired mode is shown, press the *[SET]* button for confirmation and to proceed to the next menu item.

## Locking against changes



Press the *[SET]* button repeatedly until 'ON' or 'OFF' and the  symbol are flashing in the display. Use the  or  buttons to toggle between locked status (display = 'ON') and normal operation (display = 'OFF'). In locked status, you can view the system settings, but you can't change them. In this case the display shows the  symbol.

Press the *[SET]* button to confirm the setting and proceed to the next menu item.

## Adjusting the input level

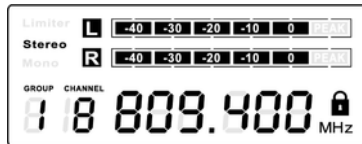

The display shows the input level of the left and right channels in a bar display. Set the input sensitivity control (2) so that signal peaks reach the '0 dB' marking. If the input level is still too low, slide the level adjustment switch (11) into the '0 dB' position.

## 6.2 Setting up the receiver



*The [SET] and [ESC] buttons that you need to set up the receiver are located behind the battery compartment lid.*

## Selecting frequency group and channel



Press the [SET] button repeatedly until the 'GROUP' field (frequency group) flashes in the display. Use the ▲ or ▼ buttons to increase or decrease the indicated value by one. When the desired value is shown press the [SET] button to confirm the setting and proceed to the next menu item. Press [ESC] to confirm the setting and exit the menu.



Press the [SET] button repeatedly until the 'CHANNEL' field flashes in the display. Use the ▲ or ▼ buttons to increase or decrease the indicated value by one. When the desired value is shown press the [SET] button to confirm the setting and proceed to the next menu item. Press [ESC] to confirm the setting and exit the menu.

In the lower area, the display shows the used transmission frequency in MHz, that is assigned to the set combination of frequency group and channel ( ↪ Chapter 8.3 'Frequency charts' on page 43).



*Transmitter and receiver must be set to the same combination of frequency group and channel. If you use multiple wireless systems from this device family, for best results you should assign all systems to the same frequency group, but give each system a different channel.*

### Turning on the treble boost





Press the *[SET]* button repeatedly until 'ON' or 'OFF' and the 'HF' field are flashing in the display. Use the ▲ or ▼ button to turn the treble boost function on or off (display = 'ON' or 'OFF'). If this function is enabled, the frequencies above 10 kHz are boosted by 6 dB and the display shows the 'HF' field. If the function is disabled, there's no treble boost.

Press the *[SET]* button to confirm the setting and proceed to the next menu item. Press *[ESC]* to confirm the setting and exit the menu.

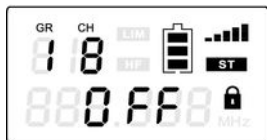
### Locking the settings



Press the *[SET]* button repeatedly until 'ON' or 'OFF' and the  symbol are flashing in the display. Use the ▲ or ▼ buttons to toggle between locked status (display = 'ON') and normal operation (display = 'OFF'). In locked status, you can view the system settings, but you can't change them. In this case the display shows the .

Press the *[SET]* button to confirm the setting and proceed to the next menu item. Press *[ESC]* to confirm the setting and exit the menu.

## 7 Troubleshooting

In the following we list a few common problems that may occur during operation. We give you some suggestions for easy troubleshooting:

Symptom	Remedy
No sound	<ol style="list-style-type: none"> <li data-bbox="624 238 1527 288">1. Check the power supply of the transmitter and receiver.</li> <li data-bbox="624 291 1527 395">2. Make sure that both transmitter and receiver operate in the same frequency range and that the transmitting antenna is designed for this frequency range. The frequency range is stated on the devices.</li> <li data-bbox="624 397 1527 473">3. Are both transmitter and receiver set to the same frequency group and the same channel?</li> <li data-bbox="624 476 1527 613">4. Check the connection between the transmitter and the connected audio device (amp, mixer). Is the connected audio device switched on and does the output signal level of the audio device match the input sensitivity of the transmitter?</li> <li data-bbox="624 616 1527 692">5. Try to improve the transmission by moving the receiver closer to the transmitter.</li> <li data-bbox="624 694 1527 770">6. Make sure that no metal objects near the transmitter or receiver obstruct the transmission.</li> </ol>
Transmission is interrupted.	<ol style="list-style-type: none"> <li data-bbox="624 772 1527 815">1. Modify the orientation of the antennas.</li> </ol>

Symptom	Remedy
	2. If you use more than one wireless system at the same time, check the used frequency groups and channels.
	3. Interference can also be caused by televisions, radios or mobile phones.
The sound is distorted.	Change the 'INPUT LEVEL' control setting on the transmitter.

If the procedures recommended above do not succeed, please contact our Service Center. You can find the contact information at [www.thomann.de](http://www.thomann.de).



## 8 Technical specifications

### 8.1 Transmitter

Input	2 × XLR / 1/4" phone combo socket (balanced)
Headphones output	1/4" phone socket (stereo)
Modulation type	Frequency modulation (FM)
Transmission level	10 dBm
Input impedance	100 kΩ
Maximum audio input level	+12 dBV
Gain range	40 dB
NF frequency response	60 Hz...16 kHz (±3 dB)
THD	< 1 % @ 1 kHz
Dynamic range	> 90 dB (A-weighted)

Operating voltage supply	DC 12...18 V $\overline{=}$ , 300 mA, via supplied power adapter
Dimensions (W × D × H, without antenna)	212 mm × 160 mm × 44 mm
Weight	960 g

## 8.2 Receiver

Modulation type	Frequency modulation (FM)
Image rejection	> 55 dB
Sensitivity	-94 dBm @ 30 dB SINAD, typical
Audio output level	100 mW
Operating voltage supply	2 × AA cell (LR6, 1.5 V)
Dimensions (W × D × H, without antenna)	105 mm × 23 mm × 64 mm
Weight (without batteries)	100 g

### 8.3 Frequency charts

#### the t.bone IEM 100 770 MHz (Item no. 269815)

##### Frequency group 1

Channel 1	Channel 2	Channel 3	Channel 4	Channel 5	Channel 6	Channel 7	Channel 8
768.000 MHz	768.625 MHz	768.975 MHz	769.350 MHz	770.175 MHz	771.125 MHz	772.725 MHz	773.375 MHz
Channel 9	Channel 10	Channel 11	Channel 12	Channel 13	Channel 14	Channel 15	Channel 16
774.525 MHz	775.075 MHz	777.050 MHz	778.675 MHz	780.100 MHz	783.325 MHz	784.175 MHz	787.950 MHz

##### Frequency group 2

Channel 1	Channel 2	Channel 3	Channel 4	Channel 5	Channel 6	Channel 7	Channel 8
768.125 MHz	769.875 MHz	770.300 MHz	771.250 MHz	772.250 MHz	773.500 MHz	774.650 MHz	775.200 MHz
Channel 9	Channel 10	Channel 11	Channel 12	Channel 13	Channel 14	Channel 15	Channel 16
777.175 MHz	778.800 MHz	780.225 MHz	781.400 MHz	783.450 MHz	785.475 MHz	786.375 MHz	787.700 MHz

**the t.bone IEM 100 770 MHz (Item no. 269815)**

**Frequency group 3**

Channel 1	Channel 2	Channel 3	Channel 4	Channel 5	Channel 6	Channel 7	Channel 8
768.425 MHz	769.775 MHz	770.600 MHz	771.050 MHz	772.075 MHz	773.150 MHz	774.950 MHz	775.500 MHz
Channel 9	Channel 10	Channel 11	Channel 12	Channel 13	Channel 14	Channel 15	Channel 16
776.250 MHz	777.475 MHz	779.100 MHz	780.525 MHz	781.700 MHz	783.750 MHz	785.775 MHz	786.675 MHz

**Frequency group 4**

Channel 1	Channel 2	Channel 3	Channel 4	Channel 5	Channel 6	Channel 7	Channel 8
768.850 MHz	769.825 MHz	770.600 MHz	771.975 MHz	772.500 MHz	772.975 MHz	773.575 MHz	774.225 MHz
Channel 9	Channel 10	Channel 11	Channel 12	Channel 13	Channel 14	Channel 15	Channel 16
775.375 MHz	776.675 MHz	777.900 MHz	779.525 MHz	781.200 MHz	783.900 MHz	784.475 MHz	786.900 MHz

**the t.bone IEM 100 770 MHz (Item no. 269815)**

**Frequency group 5**

Channel 1	Channel 2	Channel 3	Channel 4	Channel 5	Channel 6	Channel 7	Channel 8
769.125 MHz	769.750 MHz	770.475 MHz	771.300 MHz	772.250 MHz	773.850 MHz	774.500 MHz	775.650 MHz
Channel 9	Channel 10	Channel 11	Channel 12	Channel 13	Channel 14	Channel 15	Channel 16
776.200 MHz	776.950 MHz	778.175 MHz	779.800 MHz	781.475 MHz	783.325 MHz	784.175 MHz	787.175 MHz

**Frequency group 6**

Channel 1	Channel 2	Channel 3	Channel 4	Channel 5	Channel 6	Channel 7	Channel 8
769.450 MHz	770.075 MHz	770.800 MHz	771.625 MHz	772.075 MHz	773.575 MHz	774.825 MHz	775.975 MHz
Channel 9	Channel 10	Channel 11	Channel 12	Channel 13	Channel 14	Channel 15	Channel 16
776.525 MHz	777.275 MHz	778.500 MHz	780.125 MHz	781.550 MHz	782.725 MHz	784.775 MHz	785.625 MHz

## the t.bone IEM 100 770 MHz (Item no. 269815)

### Frequency group 7

Channel 1	Channel 2	Channel 3	Channel 4	Channel 5	Channel 6	Channel 7	Channel 8
769.625 MHz	770.975 MHz	771.375 MHz	772.250 MHz	773.275 MHz	774.350 MHz	775.000 MHz	776.150 MHz
Channel 9	Channel 10	Channel 11	Channel 12	Channel 13	Channel 14	Channel 15	Channel 16
777.450 MHz	778.675 MHz	780.300 MHz	781.725 MHz	782.900 MHz	784.950 MHz	785.800 MHz	787.875 MHz

### Frequency group 8

Channel 1	Channel 2	Channel 3	Channel 4	Channel 5	Channel 6	Channel 7	Channel 8
769.825 MHz	770.800 MHz	771.175 MHz	772.000 MHz	773.950 MHz	774.550 MHz	775.200 MHz	776.900 MHz
Channel 9	Channel 10	Channel 11	Channel 12	Channel 13	Channel 14	Channel 15	Channel 16
777.650 MHz	778.875 MHz	780.500 MHz	781.925 MHz	783.100 MHz	785.375 MHz	786.900 MHz	787.600 MHz

**the t.bone IEM 100 770 MHz (Item no. 269815)**

**Frequency group 9**

Channel 1	Channel 2	Channel 3	Channel 4	Channel 5	Channel 6	Channel 7	Channel 8
770.350 MHz	771.325 MHz	772.100 MHz	773.475 MHz	774.475 MHz	775.725 MHz	776.875 MHz	777.425 MHz
Channel 9	Channel 10	Channel 11	Channel 12	Channel 13	Channel 14	Channel 15	Channel 16
778.175 MHz	779.400 MHz	781.025 MHz	782.700 MHz	784.750 MHz	785.600 MHz	786.775 MHz	787.675 MHz

**Frequency group 10**

Channel 1	Channel 2	Channel 3	Channel 4	Channel 5	Channel 6	Channel 7	Channel 8
770.725 MHz	771.700 MHz	772.475 MHz	773.850 MHz	774.850 MHz	775.450 MHz	776.100 MHz	777.250 MHz
Channel 9	Channel 10	Channel 11	Channel 12	Channel 13	Channel 14	Channel 15	Channel 16
777.800 MHz	778.550 MHz	779.775 MHz	781.850 MHz	783.025 MHz	784.425 MHz	786.350 MHz	787.275 MHz

## the t.bone IEM 100 800 MHz (Item no. 137618)

### Frequency group 1

Channel 1	Channel 2	Channel 3	Channel 4	Channel 5	Channel 6	Channel 7	Channel 8
790.850 MHz	791.475 MHz	792.525 MHz	793.150 MHz	795.550 MHz	797.050 MHz	798.850 MHz	800.650 MHz
Channel 9	Channel 10	Channel 11	Channel 12	Channel 13	Channel 14	Channel 15	Channel 16
802.575 MHz	803.725 MHz	805.750 MHz	806.850 MHz	808.650 MHz	811.725 MHz	813.150 MHz	813.800 MHz

### Frequency group 2

Channel 1	Channel 2	Channel 3	Channel 4	Channel 5	Channel 6	Channel 7	Channel 8
791.400 MHz	792.600 MHz	793.925 MHz	794.200 MHz	795.725 MHz	797.750 MHz	799.400 MHz	801.475 MHz
Channel 9	Channel 10	Channel 11	Channel 12	Channel 13	Channel 14	Channel 15	Channel 16
803.100 MHz	804.775 MHz	805.800 MHz	807.400 MHz	809.200 MHz	810.200 MHz	812.775 MHz	813.750 MHz



**the t.bone IEM 100 800 MHz (Item no. 137618)**

**Frequency group 3**

Channel 1	Channel 2	Channel 3	Channel 4	Channel 5	Channel 6	Channel 7	Channel 8
790.875 MHz	791.450 MHz	792.550 MHz	793.175 MHz	795.575 MHz	797.075 MHz	798.875 MHz	801.100 MHz
Channel 9	Channel 10	Channel 11	Channel 12	Channel 13	Channel 14	Channel 15	Channel 16
802.550 MHz	803.700 MHz	805.775 MHz	806.875 MHz	808.625 MHz	811.700 MHz	813.175 MHz	813.775 MHz

**Frequency group 4**

Channel 1	Channel 2	Channel 3	Channel 4	Channel 5	Channel 6	Channel 7	Channel 8
792.625 MHz	793.100 MHz	793.450 MHz	793.950 MHz	795.025 MHz	797.300 MHz	799.425 MHz	800.625 MHz
Channel 9	Channel 10	Channel 11	Channel 12	Channel 13	Channel 14	Channel 15	Channel 16
804.800 MHz	805.250 MHz	807.475 MHz	808.550 MHz	809.975 MHz	810.325 MHz	811.600 MHz	813.300 MHz

## the t.bone IEM 100 800 MHz (Item no. 137618)

### Frequency group 5

Channel 1	Channel 2	Channel 3	Channel 4	Channel 5	Channel 6	Channel 7	Channel 8
790.900 MHz	791.425 MHz	792.575 MHz	793.200 MHz	795.600 MHz	797.100 MHz	798.900 MHz	801.125 MHz
Channel 9	Channel 10	Channel 11	Channel 12	Channel 13	Channel 14	Channel 15	Channel 16
803.025 MHz	803.675 MHz	805.300 MHz	806.900 MHz	808.600 MHz	810.050 MHz	811.675 MHz	813.125 MHz

### Frequency group 6

Channel 1	Channel 2	Channel 3	Channel 4	Channel 5	Channel 6	Channel 7	Channel 8
792.650 MHz	793.475 MHz	793.975 MHz	794.525 MHz	795.050 MHz	797.775 MHz	799.450 MHz	800.600 MHz
Channel 9	Channel 10	Channel 11	Channel 12	Channel 13	Channel 14	Channel 15	Channel 16
804.825 MHz	805.225 MHz	807.450 MHz	808.525 MHz	809.950 MHz	810.525 MHz	811.575 MHz	813.275 MHz

**the t.bone IEM 100 800 MHz (Item no. 137618)**

**Frequency group 7**

Channel 1	Channel 2	Channel 3	Channel 4	Channel 5	Channel 6	Channel 7	Channel 8
790.925 MHz	793.225 MHz	794.100 MHz	795.625 MHz	797.125 MHz	798.925 MHz	801.150 MHz	802.175 MHz
Channel 9	Channel 10	Channel 11	Channel 12	Channel 13	Channel 14	Channel 15	Channel 16
803.050 MHz	803.650 MHz	805.275 MHz	806.925 MHz	808.575 MHz	810.025 MHz	811.650 MHz	813.100 MHz

**Frequency group 8**

Channel 1	Channel 2	Channel 3	Channel 4	Channel 5	Channel 6	Channel 7	Channel 8
794.000 MHz	794.300 MHz	794.575 MHz	795.100 MHz	796.775 MHz	797.800 MHz	800.525 MHz	802.000 MHz
Channel 9	Channel 10	Channel 11	Channel 12	Channel 13	Channel 14	Channel 15	Channel 16
803.600 MHz	805.200 MHz	807.425 MHz	809.125 MHz	809.950 MHz	811.550 MHz	812.800 MHz	813.250 MHz

**the t.bone IEM 100 800 MHz (Item no. 137618)**

**Frequency group 9**

Channel 1	Channel 2	Channel 3	Channel 4	Channel 5	Channel 6	Channel 7	Channel 8
790.950 MHz	793.425 MHz	794.125 MHz	795.650 MHz	797.150 MHz	798.950 MHz	801.175 MHz	802.200 MHz
Channel 9	Channel 10	Channel 11	Channel 12	Channel 13	Channel 14	Channel 15	Channel 16
803.050 MHz	803.625 MHz	805.250 MHz	806.950 MHz	809.100 MHz	810.000 MHz	811.625 MHz	813.200 MHz

**Frequency group 10**

Channel 1	Channel 2	Channel 3	Channel 4	Channel 5	Channel 6	Channel 7	Channel 8
794.050 MHz	794.325 MHz	795.075 MHz	796.800 MHz	797.275 MHz	800.575 MHz	801.200 MHz	802.050 MHz
Channel 9	Channel 10	Channel 11	Channel 12	Channel 13	Channel 14	Channel 15	Channel 16
803.575 MHz	805.175 MHz	806.950 MHz	809.150 MHz	809.475 MHz	811.100 MHz	812.850 MHz	813.225 MHz

**the t.bone IEM 100 863 MHz (Item no. 137793)**

Channel 1	Channel 2	Channel 3	Channel 4	Channel 5	Channel 6	Channel 7	Channel 8
863.100 MHz	863.900 MHz	864.500 MHz	864.900 MHz	863.200 MHz	863.300 MHz	863.400 MHz	863.500 MHz
Channel 9	Channel 10	Channel 11	Channel 12	Channel 13	Channel 14	Channel 15	Channel 16
863.600 MHz	863.700 MHz	863.800 MHz	864.000 MHz	864.100 MHz	864.200 MHz	864.300 MHz	864.400 MHz

## 9 Protecting the environment

### Disposal of the packaging material



For the transport and protective packaging, environmentally friendly materials have been chosen that can be supplied to normal recycling.

Ensure that plastic bags, packaging, etc. are properly disposed of.

Do not just dispose these materials with your normal household waste, but make sure that they are fed to a recovery. Please follow the notes and markings on the packaging.

### Disposal of batteries



Batteries must not be disposed of as domestic waste or thrown into fire. Dispose of the batteries according to national or local regulations regarding hazardous waste. To protect the environment, dispose of empty batteries at your retail store or at appropriate collection sites.

### Disposal of your old device



This product is subject to the European Waste Electrical and Electronic Equipment Directive (WEEE) in its currently valid version. Do not dispose with your normal household waste.

Dispose this device through an approved waste disposal firm or through your local waste facility. When discarding the device, comply with the rules and regulations that apply in your country. If in doubt, consult your local waste disposal facility.





IEM 100





