



Tour Guide TG
C18, C2, 16 HAT, 16 R, 16 T
tour guide system

Musikhaus Thomann
Thomann GmbH
Hans-Thomann-Straße 1
96138 Burgebrach
Germany
Telephone: +49 (0) 9546 9223-0
E-mail: info@thomann.de
Internet: www.thomann.de

19.04.2021, ID: 234704, 234705, 234706, 235603, 278197 (V2)

Table of contents

1	General information	6
1.1	Further information.....	7
1.2	Notational conventions.....	8
1.3	Symbols and signal words.....	8
2	Safety instructions	10
3	Features and scope of delivery	13
3.1	Bodypack Transmitter TG 16 T.....	14
3.2	Handheld transmitter TG 16 HT.....	15
3.3	Bodypack Receiver TG 16 R.....	16
3.4	Charger system TG C2.....	17
3.5	Charger system TG C18.....	18
4	Installation and starting up	19
4.1	General Information.....	19
4.2	Dealing with lithium batteries.....	21

5	Connections and controls	23
5.1	Bodypack Transmitter TG 16 T.....	23
5.2	Handheld transmitter TG 16 HT.....	26
5.3	Bodypack Receiver TG 16 R.....	29
5.4	Charger system TG C2.....	32
5.5	Charger system TG C18.....	34
6	Operating	36
6.1	Bodypack Transmitter TG 16 T.....	36
6.2	Handheld transmitter TG 16 HT.....	37
6.3	Bodypack Receiver TG 16 R.....	39
6.4	Charger system TG C2.....	40
6.5	Charger system TG C18.....	40
7	Technical specifications	42
7.1	Bodypack Transmitter TG 16 T.....	42
7.2	Handheld transmitter TG 16 HT.....	43
7.3	Bodypack Receiver TG 16 R.....	45
7.4	Charger system TG C2.....	46
7.5	Charger system TG C18.....	47

7.6	Frequency table.....	48
8	Plug and connection assignment.....	50
9	Troubleshooting.....	52
10	Protecting the environment.....	55

1 General information

This user manual contains important information on the safe operation of the device. Read and follow all safety notes and all instructions. Save this manual for future reference. Make sure that it is available to all persons using this device. If you sell the device to another user, be sure that they also receive this manual.

Our products and user manuals are subject to a process of continuous development. We therefore reserve the right to make changes without notice. Please refer to the latest version of the user manual which is ready for download under www.thomann.de.

1.1 Further information

On our website (www.thomann.de) you will find lots of further information and details on the following points:

Download	This manual is also available as PDF file for you to download.
Keyword search	Use the search function in the electronic version to find the topics of interest for you quickly.
Online guides	Our online guides provide detailed information on technical basics and terms.
Personal consultation	For personal consultation please contact our technical hotline.
Service	If you have any problems with the device the customer service will gladly assist you.

1.2 Notational conventions

This manual uses the following notational conventions:

Letterings

The letterings for connectors and controls are marked by square brackets and italics.

Examples: *[VOLUME]* control, *[Mono]* button.

1.3 Symbols and signal words

In this section you will find an overview of the meaning of symbols and signal words that are used in this manual.

Signal word	Meaning
DANGER!	This combination of symbol and signal word indicates an immediate dangerous situation that will result in death or serious injury if it is not avoided.
WARNING!	This combination of symbol and signal word indicates a possible dangerous situation that can result in death or serious injury if it is not avoided.
NOTICE!	This combination of symbol and signal word indicates a possible dangerous situation that can result in material and environmental damage if it is not avoided.
Warning signs	Type of danger
	Warning – danger zone.

2 Safety instructions

Intended use

This device is intended to be used for the wireless transmission of audio signals especially for voice transmission during guided tours and events. Use the device only as described in this user manual. Any other use or use under other operating conditions is considered to be improper and may result in personal injury or property damage. No liability will be assumed for damages resulting from improper use.

This device may be used only by persons with sufficient physical, sensorial, and intellectual abilities and having corresponding knowledge and experience. Other persons may use this device only if they are supervised or instructed by a person who is responsible for their safety.

Safety



DANGER!

Danger for children

Ensure that plastic bags, packaging, etc. are disposed of properly and are not within reach of babies and young children. Choking hazard! Ensure that children do not detach any small parts (e.g. knobs or the like) from the unit. They could swallow the pieces and choke! Never let children unattended use electrical devices.

**WARNING!****Incorrect handling of lithium batteries can result in injury**

In the event of a short circuit, overheating or mechanical damage, lithium batteries can cause severe injuries. Follow the advice on the correct handling of lithium batteries in the present section.

**NOTICE!****Operating conditions**

This device has been designed for indoor use only. To prevent damage, never expose the device to any liquid or moisture. Avoid direct sunlight, heavy dirt, and strong vibrations. Only operate the device within the ambient conditions specified in the chapter 'Technical specifications' of this user manual. Avoid heavy temperature fluctuations and do not switch the device on immediately after it was exposed to temperature fluctuations (for example after transport at low outside temperatures). Dust and dirt inside can damage the unit. When operated in harmful ambient conditions (dust, smoke, nicotine, fog, etc.), the unit should be maintained by qualified service personnel at regular intervals to prevent overheating and other malfunction.

**NOTICE!****External power supply**

The device is powered by an external power supply. Before connecting the external power supply, ensure that the input voltage (AC outlet) matches the voltage rating of the device and that the AC outlet is protected by a residual current circuit breaker. Failure to do so could result in damage to the device and possibly the user. Unplug the external power supply before electrical storms occur and when the device is unused for long periods of time to reduce the risk of electric shock or fire.



NOTICE!

Risk of fire due to incorrect polarity

- Incorrectly inserted batteries may destroy the device or the batteries. Ensure that proper polarity is observed when inserting batteries.



NOTICE!

Possible damage by leaking batteries

- Leaking batteries can cause permanent damage to the device. Take batteries out of the device if it is not going to be used for a longer period.



NOTICE!

Possible damage to lithium-ion batteries through incorrect storage

- By deep discharge, lithium-ion batteries can be permanently damaged or lose some of their capacity. Before long breaks, charge the batteries to around 50 % of their capacity and then switch off the device. Store the device at room temperature or cooler in an environment as dry as possible. If the batteries are stored for a longer period, recharge them to 50 % every three months. Fully charge the batteries only shortly before use at room temperature.

3 Features and scope of delivery

The wireless tour guide system TG 16 can be used as tour guide system for visitors in many different areas where ideal voice quality and simple handling are essential. The system offers various compilation possibilities so it can be tailored easily to many different needs. The system operates within a UHF frequency range that is free of charge and registration (863 ... 865 MHz) on one out of 16 switchable frequencies. Up to three parallel systems are possible. The system is designed for mono transmission.

The tour guide system consists of the following components:

- one transmitter – either
 - Bodypack Transmitter TG 16 T
 - or
 - Handheld transmitter TG 16 HT
- as many Bodypack Receivers TG 16 R as desired

To charge the Receiver TG 16 R and Transmitter TG 16 T the following charger systems are used:

- TG C2 with two charging slots
- TG C18 with 18 charging slots

The components are available separately and as handy combinations.

3.1 Bodypack Transmitter TG 16 T

The transmitter for the wireless tour guide system TG 16 is characterized by the following features:

- Displays for set channel and operating status
- Integrated chargeable lithium battery
- Charging contacts for charger system TG C2 and TG C18
- Integrated microphone
- 3.5 mm output for separate microphone
- Housing colour: Black
- Suitable earset microphone, cloth pouch for storage, band and belt clip included.

3.2 Handheld transmitter TG 16 HT

The transmitter for the wireless tour guide system TG 16 is characterized by the following features:

- Displays for set channel and operating status
- Operating voltage supply 2 × AA cells (LR6, 1.5 V)

3.3 Bodypack Receiver TG 16 R

The transmitter for the wireless tour guide system TG 16 is characterized by the following features:

- Displays for set channel and operating status
- Integrated chargeable lithium battery
- Charging contacts for charger system TG C2 and TG C18
- Housing colour: Grey
- 3.5 mm output for ear phones
- Suitable one ear phone, band and belt clip included

3.4 Charger system TG C2

The charger system for the wireless tour guide system TG 16 is characterized by the following features:

- Two charging slots for Bodypack Transmitter TG 16 T and Bodypack Receiver TG 16 R
- Separate control LED for each charging slot
- Power supply via supplied power adapter

3.5 Charger system TG C18

The charger system for the wireless tour guide system TG 16 is characterized by the following features:

- 18 charging slots for Bodypack Transmitter TG 16 T and Bodypack Receiver TG 16 R
- Separate control LED for each charging slot
- Power supply via supplied power adapter
- Built into a handy and robust portable case

4 Installation and starting up

4.1 General Information

Unpack and check carefully there is no transportation damage before using the unit. Keep the equipment packaging. To fully protect the product against vibration, dust and moisture during transportation or storage use the original packaging or your own packaging material suitable for transport or storage, respectively.

Create all connections while the device is off. Use the shortest possible high-quality cables for all connections. Take care when running the cables to prevent tripping hazards.

Notes on wireless transmission

- This device utilizes frequencies that are not harmonized within the European Union (EU) and therefore may only be used in certain EU member states. In all European countries, the frequencies used for the transmission of audio signals are strictly regulated. Before you start, make sure the frequencies are allowed in the respective country and check whether the operation must be reported to the appropriate authority.
For more information, please visit: <http://www.thomann.de>.
- Make sure that transmitter and receiver are both tuned to the same channel.
- Never set multiple transmitters to the same channel.
- Make sure that there are no metal objects between the transmitter and receiver.
- Avoid interference from other radio or in-ear systems.

4.2 Dealing with lithium batteries



WARNING!

Incorrect handling of lithium batteries can result in injury

In the event of a short circuit, overheating or mechanical damage, lithium batteries can cause severe injuries.

Follow the advice on the correct handling of lithium batteries in the present section.

When handled correctly and appropriately lithium batteries pose no risk.

Store lithium batteries in a cool, dry place, ideally in the original packaging.

Store lithium batteries away from heat sources (e.g. radiators or sunlight). Lithium batteries are hermetically sealed. Never attempt to open a lithium battery.

If the battery housing is damaged small amounts of the electrolyte may leak out. If this should happen, seal the lithium battery in airtight packaging and wipe up the traces of electrolyte using absorbent paper towels. You must wear protective rubber gloves when doing so. Clean your hands and the affected surface thoroughly with cold water.

Never attempt to recharge non-rechargeable lithium batteries. When charging lithium batteries you must use a suitable charging device intended for the purpose.

Before disposing of the device remove the lithium batteries. Protect used lithium batteries against potential short circuits, e.g. by covering the poles with adhesive tape.

Only use powder extinguishers or other suitable extinguishing agents to extinguish a burning lithium battery.

5 Connections and controls

5.1 Bodypack Transmitter TG 16 T

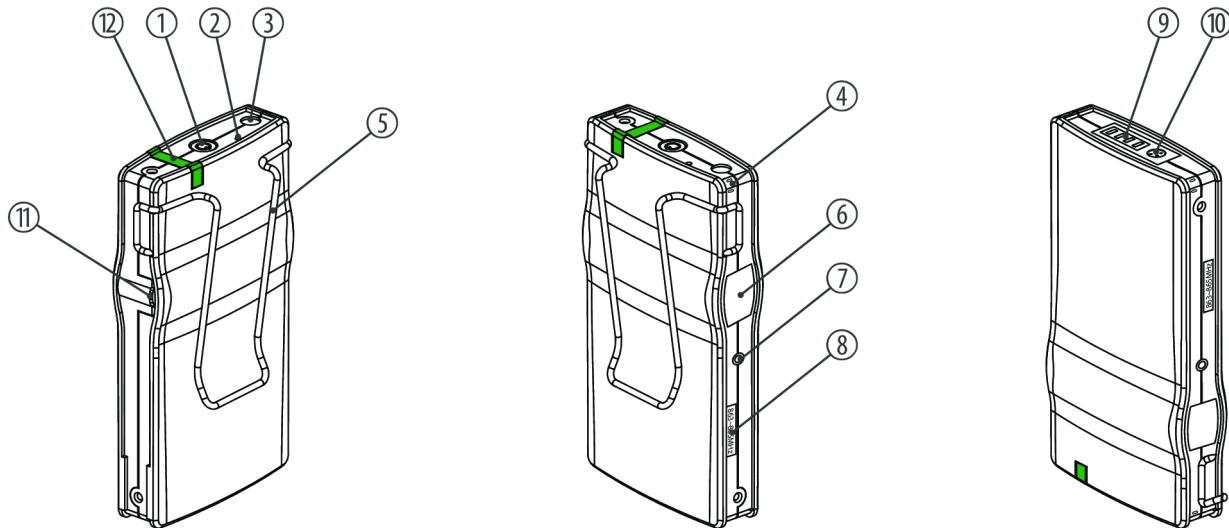

Tour Guide TG C18, C2, 16 HAT, 16 R, 16 T

1	<i>[POWER]</i> Main switch. Turns the device on and off. To turn the device on, press the button for about one second. To turn it off, press the button for about three seconds.
2	<i>[RESET]</i> Reset button for resetting the device to factory defaults.
3	<i>[MIC INPUT]</i> 3.5 mm mini phone socket (mono) to connect the supplied earset microphone or another microphone.
4	Notches for threading the band.
5	belt clip.
6	Display.
7	<i>[CHANNEL]</i> Channel selection button. Transmitter and receiver must be set to the same channel.
8	Indicating the frequency range in which the device operates. The indication here must match the information on the receiver.
9	Charging contacts.

10	MIC Built-in microphone.
11	[VOL] Volume control.
12	LED to indicate the operating status. The LED lights up green when the device is turned on. The LED lights up red when the charge of the built-in battery is too low.

5.2 Handheld transmitter TG 16 HT

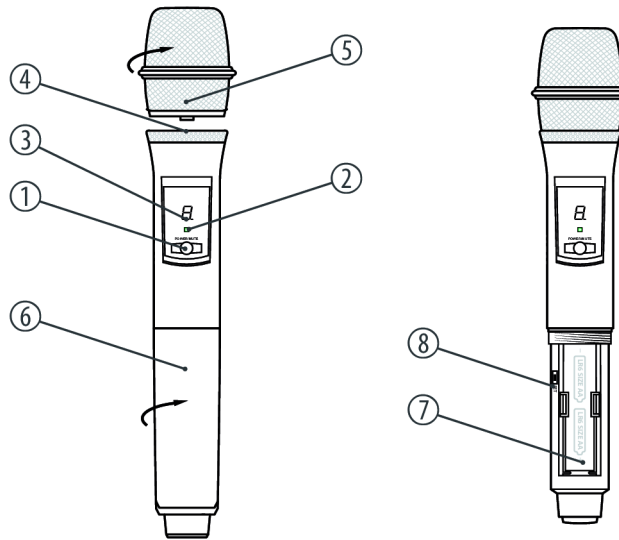

1	<i>[POWER / MUTE]</i> Power switch. Turns the device on and off or mutes it. To turn the device on and off, press the switch for about three seconds. Press the switch once briefly to mute or unmute the microphone.
2	LED to indicate the operating status. The LED lights up green when the device is turned on. The LED flashes when the device is muted and it lights up red when the charge of the built-in battery is too low.
3	Display.
4	<i>[GAIN]</i> Rotary control to adjust the volume (under the removable microphone head).
5	Removable microphone head (with screw-cap).
6	Removable cover for the battery compartment.

7	Battery compartment.
---	----------------------

7	[SET]
---	-------

Channel selection button. Transmitter and receiver must be set to the same channel.

The frequency range of the device is indicated below the button. The indication here must match the information on the receiver.

5.3 Bodypack Receiver TG 16 R

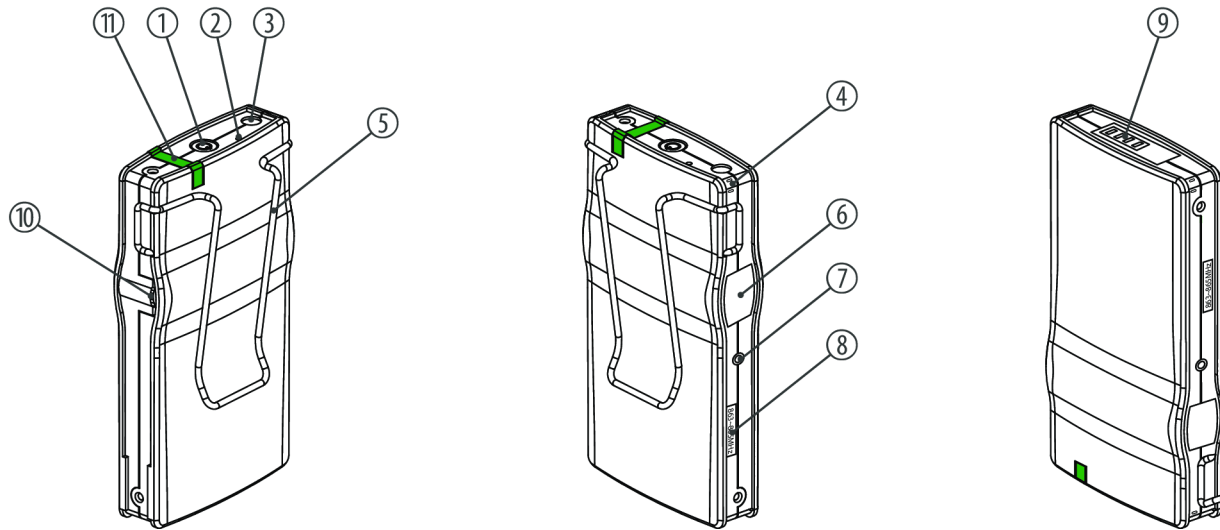

Tour Guide TG C18, C2, 16 HAT, 16 R, 16 T

1	<i>[POWER]</i> Main switch. Turns the device on and off. To turn the device on, press the button for about one second. To turn it off, press the button for about three seconds.
2	<i>[RESET]</i> Reset button for resetting the device to factory defaults.
3	3.5 mm mini phone socket (mono) to connect the supplied one ear phone or another ear phone.
4	Notches for threading the band.
5	belt clip.
6	Display.
7	<i>[CHANNEL]</i> Channel selection button. Transmitter and receiver must be set to the same channel.
8	Indicating the frequency range in which the device operates. The indication here must match the information on the transmitter.
9	Charging contacts.

10	<i>[VOL]</i> Volume control.
11	LED to indicate the operating status. The LED lights up green when the device is turned on. The LED lights up red when the charge of the built-in battery is too low.

5.4 Charger system TG C2

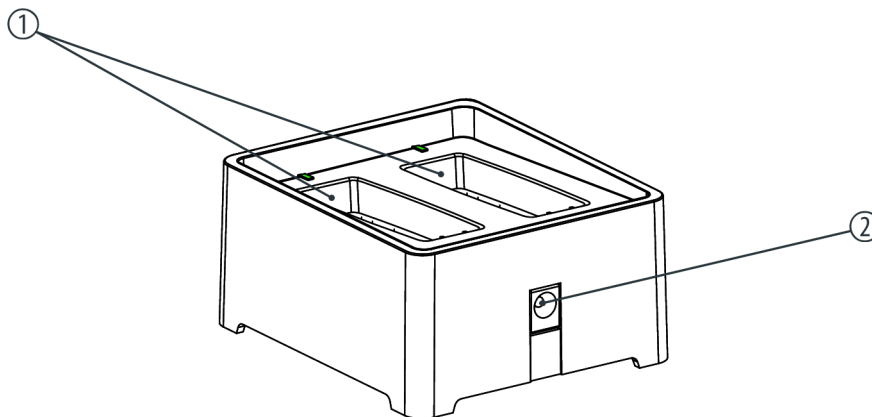

- 1 2 Charging slots for Bodypack Transmitter or Receiver with separate control LED. The LED flashes when the charging slot is free. The LED lights when the charging starts. It turns off after about 10 to 15 seconds.
- 2 Connection for the supplied power adapter.

5.5 Charger system TG C18

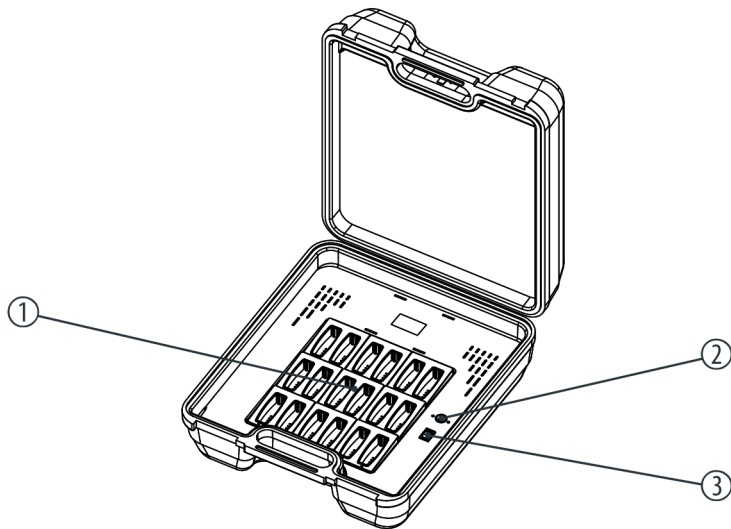

1	18 Charging slots for Bodypack Transmitter or Receiver with separate control LED. The LED flashes when the charging slot is free. The LED lights when the charging starts. It turns off after about 10 to 15 seconds.
2	<i>[DC INPUT]</i> Connection for the supplied power adapter.
3	<i>[POWER]</i> Main switch to turn the device on and off. The integrated LED indicates that the device is turned on.

6 Operating

6.1 Bodypack Transmitter TG 16 T

Preparing the unit

Thread the supplied band through the corresponding notches at the upper right corner of the housing. If you do not want to use the built-in microphone, you can connect the supplied earset microphone or another suitable microphone to the corresponding socket.

Make sure that the device is fully charged before using it.

Turning the unit on

Press *[POWER]* until the control LED lights up green. The device is now operational.

Select channel

The display at the side of the device indicates the channel that is currently set. To change the setting, press the button underneath the display until the decimal point on the display flashes. If you briefly press the button now, you can change the channel number by one each time. The channel numbers are represented by the characters „0“ ... „9“, „A“ ... „F“. If you do not press the button for about six seconds, the device works with the current settings. Transmitter and receiver must be set to the same channel.

Turning the unit off

Press *[POWER]* until the control LED turns off. The unit is turned off.

6.2 Handheld transmitter TG 16 HT

Inserting batteries into the receiver

Unscrew the bottom housing section of the hand-held microphone. Insert the batteries. Pay attention to the correct location of the poles. The correct arrangement of the batteries is indicated with symbols in the battery compartment. Remount the lower part of the housing.

Turning the unit on

Press *[POWER / MUTE]* until the control LED and the display light up. The device is now operational. The display is turned off automatically after a few seconds.

Select channel

The display on the front side of the device indicates the channel currently set after turning on the device. To change the setting, unscrew the lower part of the housing. Press *[SET]* (button next to the battery compartment) until the decimal point on the display flashes. If you briefly press the button now, you can change the channel number by one each time. The channel numbers are represented by the characters „0“ ... „9“, „A“ ... „F“. If you do not press the button for about six seconds, the device works with the current settings. Transmitter and receiver must be set to the same channel.

Mute microphone

Press briefly *[POWER / MUTE]*. The flashing control LED indicates that the microphone is now muted.

Press *[POWER / MUTE]* again to unmute the microphone.

Turning the unit off

Press *[POWER / MUTE]* until the control LED turns off. The unit is turned off.

6.3 Bodypack Receiver TG 16 R

Preparing the unit

Thread the supplied band through the corresponding notches at the upper right corner of the housing. Connect the supplied one ear phone or another ear phone to the corresponding socket.

Make sure that the device is fully charged before using it.

Turning the unit on

Press *[POWER]* until the control LED lights up green. The device is now operational.

Select channel

The display at the side of the device indicates the channel that is currently set. To change the setting, press the button underneath the display until the decimal point on the display flashes. If you briefly press the button now, you can change the channel number by one each time. The channel numbers are represented by the characters „0“ ... „9“, „A“ ... „F“. If you do not press the button for about six seconds, the device works with the current settings. Transmitter and receiver must be set to the same channel.

Turning the unit off

Press *[POWER]* until the control LED turns off. The unit is turned off.

6.4 Charger system TG C2

Preparing the unit

Connect the supplied power adapter with the power supply input of the unit. Then connect the power adapter to a power outlet.

Charging Bodypack units

Turn off the Bodypack Transmitter or Receiver that needs charging. Position the charging contacts of the Bodypack unit over the charging contacts of the charging slot. Insert the Bodypack unit into the charging slot so that it clicks into place. The control LED of the charging slot turns off. It lights up again when the device is fully charged.

6.5 Charger system TG C18

Preparing the unit

Connect the supplied power adapter with the power supply input of the unit. Then connect the power adapter to a power outlet. Using the main switch, turn the device on. The integrated control LED lights up red.

Charging Bodypack units

Turn off the Bodypack Transmitter or Receiver that needs charging. Position the charging contacts of the Bodypack unit over the charging contacts of the charging slot. Insert the Bodypack unit into the charging slot so that it clicks into place. The control LED of the charging slot turns off. It lights up again when the device is fully charged.

7 Technical specifications

7.1 Bodypack Transmitter TG 16 T

Functional principle	PLL synthesized control	
Inputs	Microphone	1 × 3.5 mm jack socket
Frequency of operation	863 MHz ... 865 MHz	
Max. transmission power	10 mW	
Range (free field)	50 m	
Stability	±0.005 %	
Frequency deviation	±48 kHz	
Spurious emissions	< -50 dBC	
NF frequency response	40 Hz ... 18 kHz	
Battery	Battery type	Lithium-ion

	Voltage	3.7 V
	Operating time	14 h
Dimensions (W × H × D)	54 mm × 99 mm × 17 mm	
Weight	80 g	
Ambient conditions	Temperature range	0 °C...40 °C
	relative humidity	20 %...80 % (non-condensing)

7.2 Handheld transmitter TG 16 HT

Functional principle	PLL synthesized control
Frequency of operation	863 MHz ... 865 MHz
Max. transmission power	10 mW

Technical specifications

Range (free field)	50 m	
NF frequency response	40 Hz ... 16.5 kHz	
Battery	Battery type	2 × round cell batteries AA LR06
	Voltage	1.5 V
	Operating time	14 h
Dimensions (Ø × L)	50 mm × 265 mm	
Weight	215 g	
Ambient conditions	Temperature range	0 °C...40 °C
	relative humidity	20 %...80 % (non-condensing)

7.3 Bodypack Receiver TG 16 R

Functional principle	PLL synthesized control	
Max. number of parallel systems	3 systems	
Output connections	Earphones	1 × 3.5 mm jack socket
Frequency of operation	863 MHz ... 865 MHz	
Sensitivity	-95 dBm	
Antenna gain	2 dBi	
NF frequency response	40 Hz ... 18 kHz	
Battery	Battery type	Lithium-ion
	Voltage	3.7 V
	Operating time	14 h
	Charging time in the device	approx. 8 h
Dimensions (W × H × D)	54 mm × 99 mm × 17 mm	

Weight	80 g	
Ambient conditions	Temperature range	0 °C...40 °C
	relative humidity	20 %...80 % (non-condensing)

7.4 Charger system TG C2

Loading slots	2
Power supply	External power adapter, 100 - 240 V ~ 50/60 Hz
Operating voltage	12 V ... 18 V $\overline{\text{=}}$ / 600 mA , centre positive
Charging time	approx. 8 h
Dimensions (W x H x D)	85 mm x 41 mm x 75 mm
Weight	115 g

Ambient conditions	Temperature range	0 °C...40 °C
	relative humidity	20 %...80 % (non-condensing)

7.5 Charger system TG C18

Loading slots	18
Power supply	External power adapter, 100 - 240 V ~ 50/60 Hz
Operating voltage	15 V $\overline{\text{---}}$ / 3.3 A , positive centre
Dimensions (W × H × D)	361 mm × 189 mm × 422 mm
Weight	3.4 kg

Ambient conditions	Temperature range	0 °C...40 °C
	relative humidity	20 %...80 % (non-condensing)

7.6 Frequency table

Channel	Display	Frequency (MHz)	Channel	Display	Frequency (MHz)
1	0	863.125	9	8	864.125
2	1	863.250	10	9	864.250
3	2	863.375	11	A	864.375
4	3	863.500	12	B	864.500
5	4	863.625	13	C	864.625
6	5	863.750	14	D	864.750

Channel	Display	Frequency (MHz)	Channel	Display	Frequency (MHz)
7	6	863.875	15	E	864.875
8	7	864.000	16	F	865.000

8 Plug and connection assignment

Introduction

This chapter will help you select the right cables and plugs to connect your valuable equipment in such a way that a perfect sound experience is ensured.

Please note these advices, because especially in 'Sound & Light' caution is indicated: Even if a plug fits into the socket, an incorrect connection may result in a destroyed power amp, a short circuit or 'just' in poor transmission quality!

Balanced and unbalanced transmission

Unbalanced transmission is mainly used in semi-professional environment and in hifi use. Instrument cables with two conductors (one core plus shielding) are typical representatives of the unbalanced transmission. One conductor is ground and shielding while the signal is transmitted through the core.

Unbalanced transmission is susceptible to electromagnetic interference, especially at low levels, such as microphone signals and when using long cables.

In a professional environment, therefore, the balanced transmission is preferred, because this enables an undisturbed transmission of signals over long distances. In addition to the conductors 'Ground' and 'Signal', in a balanced transmission a second core is added. This also transfers the signal, but phase-shifted by 180°.

Since the interference affects both cores equally, by subtracting the phase-shifted signals, the interfering signal is completely neutralized. The result is a pure signal without any noise interference.

**Three-pole 1/8" mini phone jack
(stereo, unbalanced)**



1	Signal (left)
2	Signal (right)
3	Ground, shielding

9 Troubleshooting

In the following we list a few common problems that may occur during operation. We give you some suggestions for easy troubleshooting:

Symptom	Remedy
No sound	<ol style="list-style-type: none"> 1. Check the power supply of transmitter and receiver. 2. Make sure that transmitter and receiver are operating in the same frequency range. The frequency can be found on the devices. 3. Are transmitter and receiver set to the same channel? 4. Check the connection between the transmitter and the connected microphone and the receiver and the connected ear phone. 5. See if the sound transmission works when you move the receiver closer to the transmitter. 6. Make sure that no metal objects near the transmitter or receiver obstruct the transmission.
Transmission is interrupted.	<ol style="list-style-type: none"> 1. If you use more than one wireless system at the same time, check the used frequency groups and channels. 2. Interference can also be caused by televisions, radios or mobile phones.
The sound is distorted.	Change the volume setting of the transmitter and the receiver for test purposes.

If the procedures recommended above do not succeed, please contact our Service Center. You can find the contact information at www.thomann.de.

10 Protecting the environment

Disposal of the packaging material



For the packaging, environmentally friendly materials have been chosen that can be supplied to normal recycling.

Ensure that plastic bags, packaging, etc. are properly disposed of.

Do not just dispose of these materials with your normal household waste, but make sure that they are collected for recycling. Please follow the notes and markings on the packaging.

Disposal of batteries



Batteries do contain some hazardous chemicals so they should not be thrown away with the normal household waste. They should be returned to the manufacturer for disposal or recycled elsewhere in accordance with your local regulations.

Dispose lithium batteries only in discharged condition. Remove lithium batteries from the device before disposal. Protect used lithium batteries against potential short circuits, e.g. by covering the poles with adhesive tape. Dispose the built-in lithium batteries together with the device. Please check for an appropriate reception facility.

Disposal of your old device



This product is subject to the European Waste Electrical and Electronic Equipment Directive (WEEE) in its currently valid version. Do not dispose with your normal household waste.

Dispose of this device through an approved waste disposal firm or through your local waste facility. When discarding the device, comply with the rules and regulations that apply in your country. If in doubt, consult your local waste disposal facility.

Tour Guide TG C18, C2, 16 HAT, 16 R, 16 T



Musikhaus Thomann · Hans-Thomann-Straße 1 · 96138 Burgebrach · Germany · www.thomann.de