

the
box **pro**

A 10 LA
line array element

Musikhaus Thomann
Thomann GmbH
Hans-Thomann-Straße 1
96138 Burgebrach
Germany
Telephone: +49 (0) 9546 9223-0
E-mail: info@thomann.de
Internet: www.thomann.de

11.02.2020, ID: 313500 (V3)

Table of contents

1	General information	4
	1.1 Further information.....	5
	1.2 Notational conventions.....	6
	1.3 Symbols and signal words.....	7
2	Safety instructions	9
3	Features	14
4	Installation	15
	4.1 Installation.....	17
5	Connections and controls	24
6	Starting up	30
7	Networking and remote control	31
8	Technical specifications	35
9	Plug and connection assignment	37
10	Protecting the environment	39

1 General information

This user manual contains important information on the safe operation of the device. Read and follow all safety notes and all instructions. Save this manual for future reference. Make sure that it is available to all persons using this device. If you sell the device to another user, be sure that they also receive this manual.

Our products and user manuals are subject to a process of continuous development. We therefore reserve the right to make changes without notice. Please refer to the latest version of the user manual which is ready for download under www.thomann.de.

1.1 Further information

On our website (www.thomann.de) you will find lots of further information and details on the following points:

Download	This manual is also available as PDF file for you to download.
Keyword search	Use the search function in the electronic version to find the topics of interest for you quickly.
Online guides	Our online guides provide detailed information on technical basics and terms.
Personal consultation	For personal consultation please contact our technical hotline.
Service	If you have any problems with the device the customer service will gladly assist you.

1.2 Notational conventions

This manual uses the following notational conventions:

Letterings

The letterings for connectors and controls are marked by square brackets and italics.

Examples: *[VOLUME]* control, *[Mono]* button.

Instructions

The individual steps of an instruction are numbered consecutively. The result of a step is indented and highlighted by an arrow.



Example:

- 1.** ▶ Switch on the device.
- 2.** ▶ Press *[Auto]*.
 - ⇒ Automatic operation is started.
- 3.** ▶ Switch off the device.

1.3 Symbols and signal words

In this section you will find an overview of the meaning of symbols and signal words that are used in this manual.

Signal word	Meaning
DANGER!	This combination of symbol and signal word indicates an immediate dangerous situation that will result in death or serious injury if it is not avoided.
WARNING!	This combination of symbol and signal word indicates a possible dangerous situation that can result in death or serious injury if it is not avoided.
CAUTION!	This combination of symbol and signal word indicates a possible dangerous situation that can result in minor injury if it is not avoided.
NOTICE!	This combination of symbol and signal word indicates a possible dangerous situation that can result in material and environmental damage if it is not avoided.

Warning signs	Type of danger
 A yellow triangular warning sign with a black border and a black lightning bolt symbol in the center.	Warning – high-voltage.
 A yellow triangular warning sign with a black border and a black symbol of a crane hook lifting a rectangular load.	Warning – suspended load.
 A yellow triangular warning sign with a black border and a black exclamation mark in the center.	Warning – danger zone.

2 Safety instructions

Intended use

This device is designed for sound reinforcement. Use the device only as described in this user manual. Any other use or use under other operating conditions is considered to be improper and may result in personal injury or property damage. No liability will be assumed for damages resulting from improper use.

This device may be used only by persons with sufficient physical, sensorial, and intellectual abilities and having corresponding knowledge and experience. Other persons may use this device only if they are supervised or instructed by a person who is responsible for their safety.

Safety



DANGER!

Danger for children

Ensure that plastic bags, packaging, etc. are disposed of properly and are not within reach of babies and young children. Choking hazard!

Ensure that children do not detach any small parts (e.g. knobs or the like) from the unit. They could swallow the pieces and choke!

Never let children unattended use electrical devices.



DANGER!

Electric shock caused by high voltages inside

Within the device there are areas where high voltages may be present. Never remove any covers.

There are no user-serviceable parts inside.

Do not use the device if covers, protectors or optical components are missing or damaged.



DANGER!

Electric shock caused by short-circuit

Always use proper ready-made insulated mains cabling (power cord). Do not modify the mains cable. Failure to do so could result in electric shock/death or fire. If in doubt, seek advice from a registered electrician.



CAUTION!

Possible hearing damage

The device can produce volume levels that may cause temporary or permanent hearing impairment. Over an extended period of time, even levels that seem to be uncritical can cause hearing damage.

Decrease the volume level immediately if you experience ringing in your ears or hearing impairment. If this is not possible, keep a greater distance or use sufficient ear protectors.



NOTICE!

Risk of fire

Do not block areas of ventilation. Do not install the device near any direct heat source. Keep the device away from naked flames.



NOTICE!

Operating conditions

This device has been designed for indoor use only. To prevent damage, never expose the device to any liquid or moisture. Avoid direct sunlight, heavy dirt, and strong vibrations.

Only operate the device within the ambient conditions specified in the chapter 'Technical specifications' of this user manual. Avoid heavy temperature fluctuations and do not switch the device on immediately after it was exposed to temperature fluctuations (for example after transport at low outside temperatures).

Dust and dirt inside can damage the unit. When operated in harmful ambient conditions (dust, smoke, nicotine, fog, etc.), the unit should be maintained by qualified service personnel at regular intervals to prevent overheating and other malfunction.



NOTICE!

Power supply

Before connecting the device, ensure that the input voltage (AC outlet) matches the voltage rating of the device and that the AC outlet is protected by a residual current circuit breaker. Failure to do so could result in damage to the device and possibly injure the user.

Unplug the device before electrical storms occur and when it is unused for long periods of time to reduce the risk of electric shock or fire.

3 Features

Special features of the device:

- Active line array element featuring 2 × 1.4" tweeters with titanium diaphragm and 2 × 10" woofers with 2.5" aluminum voice coil
- 2 × 1000 W Class D amplifier
- XLR in and output
- Lockable input socket (Power Twist) for power supply.
- Frequency response: 75 Hz ... 18 kHz
- Dispersion angle (H × V) 110° × 10°
- Maximum sound pressure level: 131 dB
- Internal Digital Signal Processor (DSP) with four presets
- Network port for connecting a notebook/PC using exclusively the CanBus converters (item no.: 440591 the box pro USB2CAN CanBus Converter) and the Pronet software (free download from www.thomann.de).
- Mounting in flown or stacked line arrays with optionally available accessory
- Birch plywood housing with waterproof paint

4 Installation

Unpack and check carefully there is no transportation damage before using the unit. Keep the equipment packaging. To fully protect the product against vibration, dust and moisture during transportation or storage use the original packaging or your own packaging material suitable for transport or storage, respectively.

Create all connections while the device is off. Use the shortest possible high-quality cables for all connections. Take care when running the cables to prevent tripping hazards.



WARNING!

Risk of injury caused by falling objects

Make sure that the installation complies with the standards and rules that apply in your country. Always secure the device with a secondary safety attachment, such as a safety cable or a safety chain.



CAUTION!

Risk of injury due to heavy weight

Due to the heavy weight of the device, at least two persons are required for transport and installation.



NOTICE!

Possible property damage by magnetic fields

Loudspeakers produce a static magnetic field. Therefore, maintain an appropriate distance to devices that can be adversely affected or damaged by an external magnetic field.



NOTICE!

Use of stands

When mounting the device onto a stand, ensure that the stand is in a safe and stable position and that the weight of the device does not exceed the maximum permissible load capacity of the stand.

4.1 Installation

Overview

Due to its mechanical structure, the device can either be individually put on the ground or hung, or arranged to line arrays of variable size. The units can be joined together using the built-in fasteners without any additional parts. For easy, flexible and secure mounting, the flying frame (item number 313502) is available as optional accessories. This section shows how easy the assembly is.

Connecting the devices to each other

To the left and right of the front panel, a safety pin is attached, allowing you to stably connect the unit to the one directly above it. There is a fold-out vertical latch on the rear panel. This latch fits into the U-rail of the device mounted below, which has a series of numbered bores. Attach the latch of the upper unit to the U-rail of the underlying device with a safety pin. By selecting the hole, you can set the desired angle of inclination. Figure and table show the mechanical parts on the rear side and its function.

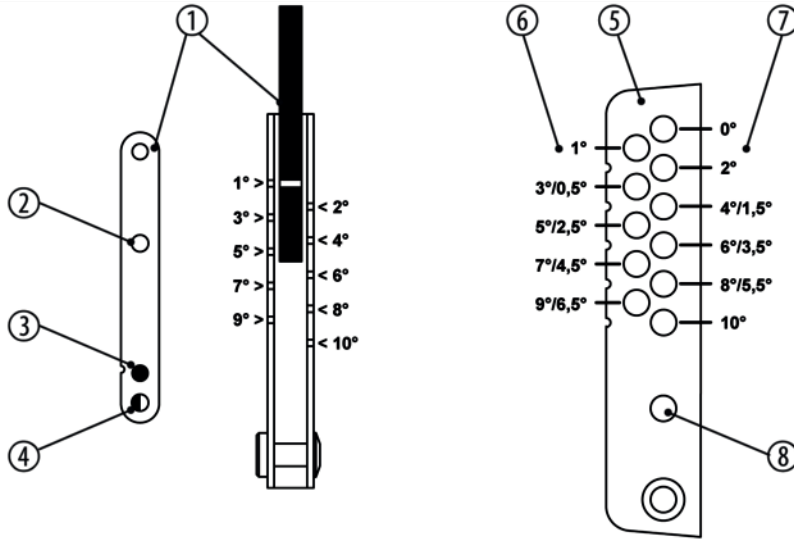

1	Vertical latch of the overlying unit (in longitudinal and lateral view).
2	Securing bore in the vertical latch. Use this bore when the vertical latch of the device is not folded down, so for single installation or for the lowest unit in a system.
3	Bore for angular steps of 1 °.
4	Bore for angular steps of 0.5°.
5	U-rail of the device (side view).
6	Clearance bores for odd-numbered angles.
7	Clearance bores for even-numbered angles.
8	Use this bore of the U-rail when the vertical latch of the device is not folded down, so for single installation or for the lowest unit in a system.

Flying frame

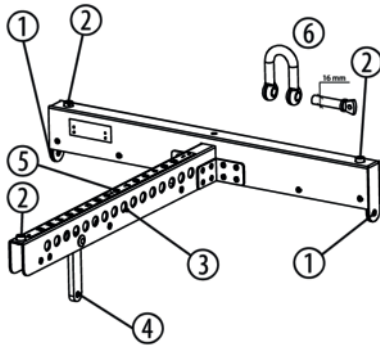

- | | |
|---|--|
| 1 | Bores for locking pin. |
| 2 | Thread (M10) for attaching standard screw feet for stack mounting. |
| 3 | Clearance bores. |
| 4 | Vertical latch, suitable for the U-rail of the devices |
| 5 | Numbering of the clearance bores. |
| 6 | 16 mm shackle, optionally available as accessory (item number 323399). |

Installation of a flown system

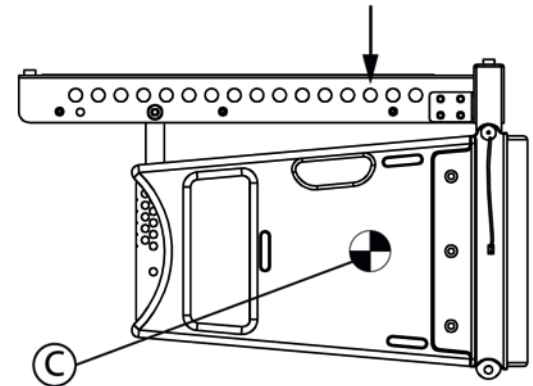
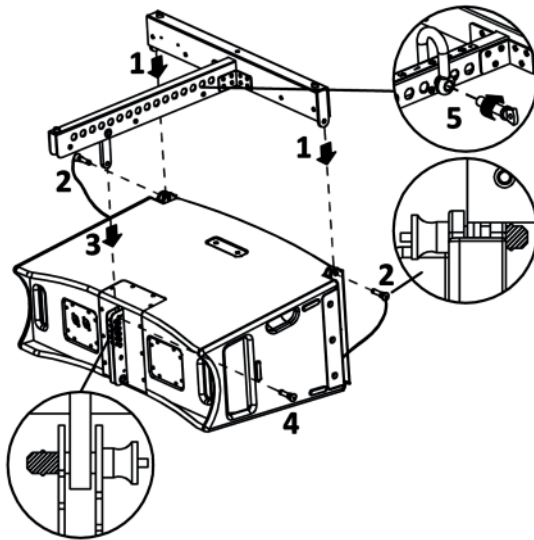

1. ➤ Attach the flying frame left and right at the front panel of top unit.
2. ➤ Secure the flying frame with the locking pins that are attached to the top unit.

A 10 LA

3. ▶ Position the vertical latch of the flight frame in the U-rail of the top unit.
4. ▶ Secure the latch in the correct position with a safety pin at the U-rail.
5. ▶ For flying operation, mount a shackle on the flying frame. It must be located directly above the centre of gravity of the entire system. In the figure, the centre of gravity is marked by 'C', the arrow shows the correct position of the U-shackle for this installation situation.

Assembly of a device for positioning

The flying frame can also be used as a framework for positioning of a device on the floor. In this case, turn the unit by 180° upside down and attach it to the flying frame, as described in chapter Installation of a flown system. Then turn the whole thing around and put the flying frame with the rubber feet on the ground.

Mounting multiple devices in a system

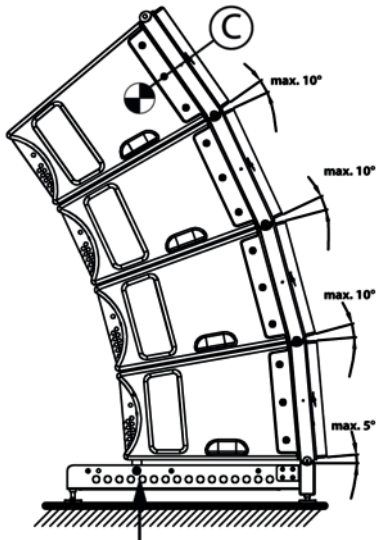

Usually, several units are so installed to a line array, that they are arranged arcuately. The figure alongside shows an example of how four elements can be combined into a system that stands on the ground (ground stack). In the figure, the centre of gravity is marked by 'C'.



In a ground stack, no more than four elements with maximum angulation may be used.

In flying operation, the shackle must be mounted just above the centre of gravity of the entire system.

5 Connections and controls

Rear panel, left side

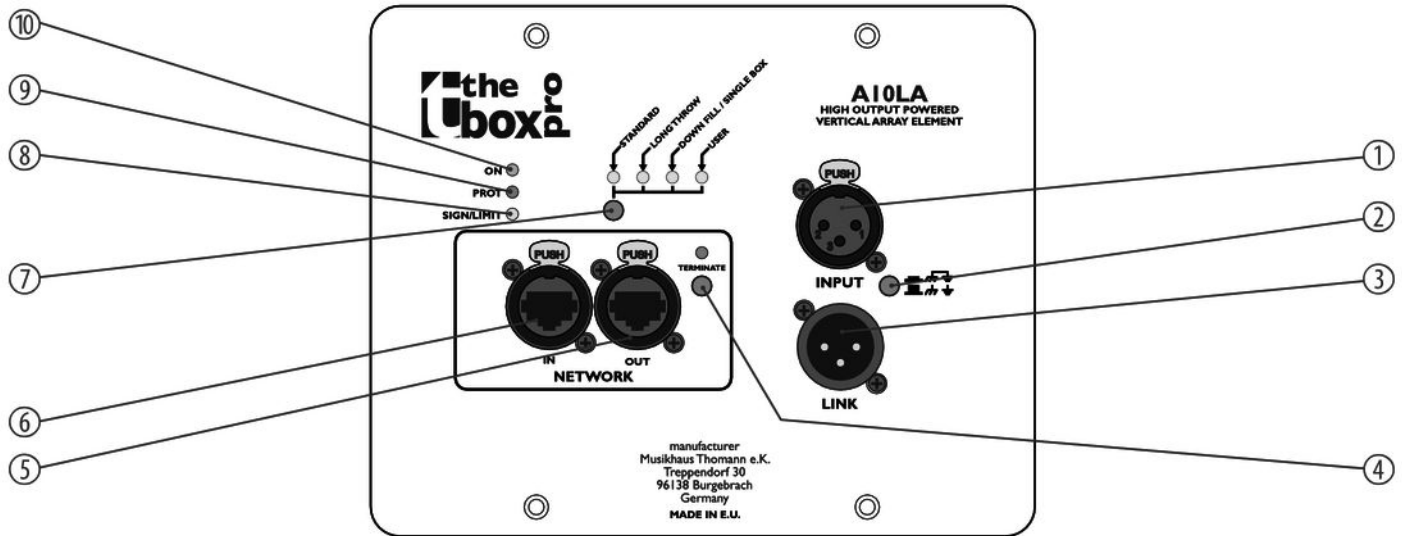

line array element

1	<p><i>[INPUT]</i></p> <p>Audio signal input with lockable XLR chassis socket. The socket is electronically perfectly symmetrical wired to achieve an optimal signal-to-noise ratio and a sufficient power reserve, including A / D conversion.</p>
2	<p><i>[GND LIFT]</i> pushbutton</p> <p>If hum is caused by a ground loop, you can use this switch to disconnect the connection between the earth pin of the device and the signal ground of the device. Switching only has an effect when using balanced connection cables.</p>
3	<p><i>[LINK]</i></p> <p>Audio signal output with XLR chassis plug to connect other line array elements or speakers to which the input signal is passed.</p>
4	<p><i>[TERMINATE]</i> pushbutton</p> <p>If the devices of a line arrays are networked together, the last unit must be terminated with the built-in load resistance. Press the pushbutton <i>[TERMINATE]</i>. The LED above it lights up.</p>
5,6	<p><i>[NETWORK IN/OUT]</i></p> <p>RJ45 CAT5 connectors for establishing a network connection to the CanBus Converter (item number 440591), to the Pronet software and to the line array elements.</p>

7 Preset button

This button has two functions:

- If kept pressed while turning the device on, the ID assignment is made. The internal digital signal processor (DSP) assigns a new ID to the device for the remote control within the Pronet network. Each device must have a unique ID so that it can be represented in the Pronet network. If you assign a new ID, all devices with already assigned IDs must be turned on and connected to the Pronet network.
- If the device is already on, pressing the button selects the DSP preset. The selected preset is indicated by the corresponding LED.
 - *[STANDARD]*

This setting is suitable for vertically flown line arrays, which consist of four to eight devices, or for the middle area of a larger flown array. It can also be used for stacked arrays.
 - *[LONG THROW]*

This setting can be used in arrays with more than six or eight devices and be loaded in the top or the top two devices in order to achieve a more balanced distribution of sound pressure, especially when these devices are aimed at distant targets or the upper galleries of a large house.
 - *[DOWN FILL / SINGLE BOX]*

This setting, which provides a much smoother frequency response can be loaded in the lower (usually one or two) devices of a large flown array to achieve a pleasant sound for the audience near the stage. This setting is also very useful if the device is used alone at the front on very large stages.
 - *[USER]*

	<p>This LED lights up when the user setting is loaded. This setting corresponds to the user preset no. 1 of the DSP. In delivered condition, the user setting is identical to the setting <i>[STANDARD]</i>. If you want to change it, you must connect the device to a notebook/PC using the CanBus converter, edit the parameters using the Pronet software, and save the setting to user memory preset no. 1.</p>
8	<p>LED <i>[SIGN/LIMIT]</i></p> <p>This LED lights green when an input signal is present.</p> <p>This LED lights red when the internal output signal is limited (due to excessive input signal level!).</p>
9	<p>LED <i>[PROT]</i></p> <p>This LED lights red when the protection circuit of the amplifier module responds due to an internal error and the amplifier is therefore muted.</p> <p>This LED lights red when the internal output signal is limited (due to excessive input signal level!).</p>
10	<p>LED <i>[ON]</i></p> <p>This LED lights green when the unit is turned on and the power supply voltage is present.</p>

Rear panel, right side.

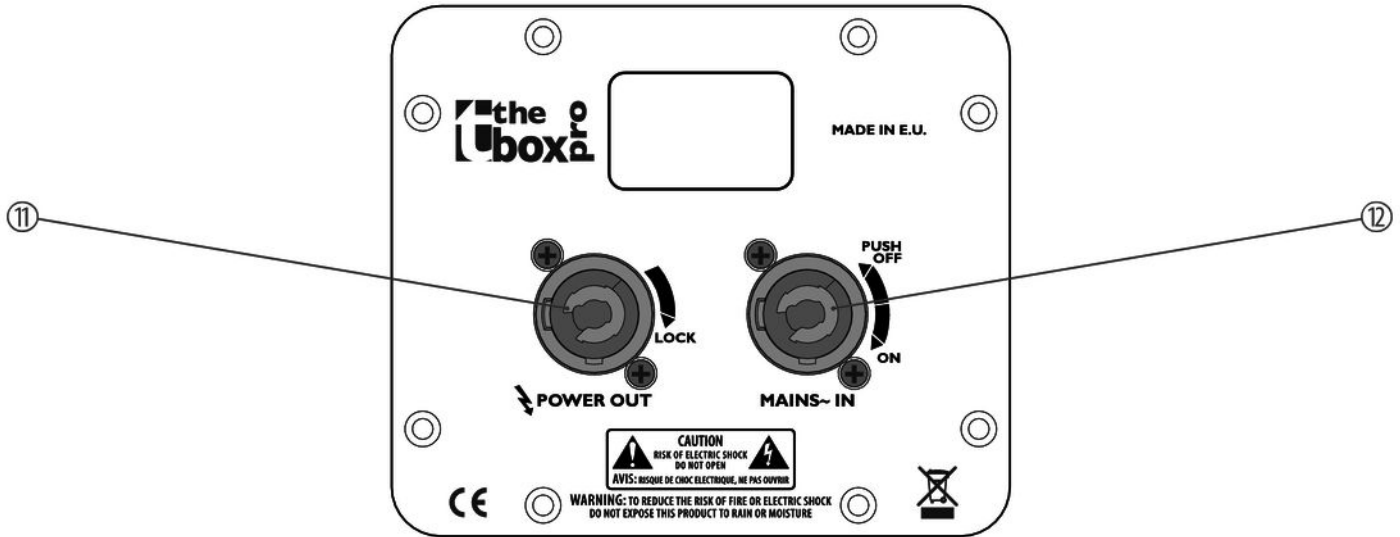

11 *[POWER OUT]*

Gray lockable output socket (Power Twist). This output is looped through from the blue input socket *[MAINS IN]*. You can use it to feed the power supply to the blue input sockets *[MAINS IN]* of further elements. A maximum of four line array elements can be connected.

12 *[MAINS IN]*

Blue lockable input socket (Power Twist). To turn the unit on, plug the power cord or the connector cable from another device into this socket and turn the plug clockwise to the position *[ON]*. To turn the unit off, pull the locking lever on the plug backwards and turn the plug counter-clockwise to the position *[PUSH OFF]*.

6 Starting up

Switching on

After you have made all the required connections, turn on the audio system.

It is recommended to provide one switch for turning on the entire audio system and to always leave the plugs (Power Twist) connected to the sockets of the individual elements. With this simple trick you can extend the life of the connectors.

DSP preset

Select the desired DSP preset (**STANDARD, LONG THROW, DOWN FILL/SINGLE BOX** or **USER**).

7 Networking and remote control

Network capability

Using the network ports on the rear panel, the individual devices of the entire audio system can be networked and controlled remotely with a notebook or PC.

Pronet

The communication protocol used in the Pronet network is CanBus.

USB2CAN

All you need to build such a network is the free Thomann Pronet software offered in the Thomann Cyberstore for download, the CanBus Converter (item number 440591) available from Thomann and a notebook or PC. Installation and user's guides are included in the free download of the software.

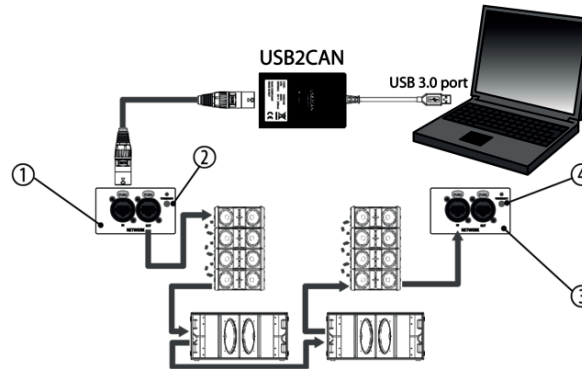

- 1 Network ports on the rear panel of the first unit.
- 2 [TERMINATE] pushbutton must not be pressed.
The LED above it is off.

3	Network ports on the rear panel of the last unit.
4	<i>[TERMINATE]</i> pushbutton must be pressed. The LED above it is on.

Network setup and termination

The individual units must be linearly linked by RJ45 CAT5 cable. Beginning and end of the network bus must be terminated. The beginning is terminated by the CanBus converter. At the end, the *[TERMINATE]* switch must be pressed on the rear panel of the last unit to enable the built-in terminating resistor for termination. The *[TERMINATE]* switch on all units between the CanBus converter and the last device must not be pressed.

ID assignment

Each device of a Pronet network must have a unique identifier or ID. By default, the USB2CAN converter has the ID 0. Any other device can only have an ID equal or higher than 1. There must be no devices with the same ID on the network. The ID is assigned automatically when a device connected to the network is turned on for the first time.

Proceed as follows to assign a unique ID to all devices in the Pronet network:

1. Turn off all devices.
2. Connect them with the RJ-45 CAT5 cables in the desired order.

3. ▶ Press the *[TERMINATE]* button on the rear panel of the last unit.
4. ▶ Turn on the first device while keeping its *[PRESET]* button pressed on the rear panel.
5. ▶ Leave the first device turned on and repeat step 4 for all other devices until the last device is turned on.

When a new device is to be added, only step 4 must be repeated. Each device keeps its ID, even if it is turned off, as it is stored in the internal memory of the device. The ID is only deleted or reassigned by explicit allocation as described above. Find more detailed information and instructions in the User Manual supplied with the Pronet software.

8 Technical specifications

Speaker	2 × 1.4" tweeters with titanium diaphragm and 2 × 10" woofers with 2.5" aluminum voice coil	
Input connections	Power supply	1 × lockable input socket (Power Twist)
	Audio signal	1 × XLR panel socket, 3-pin (balanced)
	Network connection	1 × RJ45-CAT5 input socket
Input impedance	20 kΩ	
Input sensitivity	+4 dBu / 1.25 V	
Output connections	Power supply of further devices	1 × lockable input socket (Power Twist)
	Audio signal	1 × XLR panel socket, 3-pin (balanced)
	Network connection	1 × RJ45-CAT5 input socket
Output power	2 × 1000 W (RMS)	
Frequency range	75 Hz...18 kHz, ± 3 dB	

Technical specifications

Beam angle	10° × 110°	
Sound pressure level (SPL), max.	131 dB	
Power consumption	700 W (nominal)	
	1700 W (max.)	
Operating supply voltage	230 V ~ 50 Hz	
Dimensions (W × H × D)	746 mm × 530 mm × 341 mm	
Weight	40 kg	
Ambient conditions	Temperature range	0 °C...40 °C
	Relative humidity	50 %, non-condensing

9 Plug and connection assignment

Introduction

This chapter will help you select the right cables and plugs to connect your valuable equipment in such a way that a perfect sound experience is ensured.

Please note these advices, because especially in 'Sound & Light' caution is indicated: Even if a plug fits into the socket, an incorrect connection may result in a destroyed power amp, a short circuit or 'just' in poor transmission quality!

Balanced and unbalanced transmission

Unbalanced transmission is mainly used in semi-professional environment and in hifi use. Instrument cables with two conductors (one core plus shielding) are typical representatives of the unbalanced transmission. One conductor is ground and shielding while the signal is transmitted through the core.

Unbalanced transmission is susceptible to electromagnetic interference, especially at low levels, such as microphone signals and when using long cables.

In a professional environment, therefore, the balanced transmission is preferred, because this enables an undisturbed transmission of signals over long distances. In addition to the conductors 'Ground' and 'Signal', in a balanced transmission a second core is added. This also transfers the signal, but phase-shifted by 180°.

Since the interference affects both cores equally, by subtracting the phase-shifted signals, the interfering signal is completely neutralized. The result is a pure signal without any noise interference.

XLR plug (balanced)

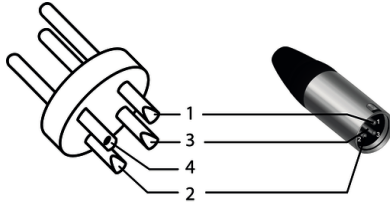

1	Ground, shielding
2	Signal (in phase, +)
3	Signal (out of phase, -)
4	Shielding on plug housing (option)

10 Protecting the environment

Disposal of the packaging material



For the transport and protective packaging, environmentally friendly materials have been chosen that can be supplied to normal recycling.

Ensure that plastic bags, packaging, etc. are properly disposed of.

Do not just dispose of these materials with your normal household waste, but make sure that they are collected for recycling. Please follow the notes and markings on the packaging.

Disposal of your old device



This product is subject to the European Waste Electrical and Electronic Equipment Directive (WEEE) in its currently valid version. Do not dispose with your normal household waste.

Dispose of this device through an approved waste disposal firm or through your local waste facility. When discarding the device, comply with the rules and regulations that apply in your country. If in doubt, consult your local waste disposal facility.

A 10 LA



Musikhaus Thomann · Hans-Thomann-Straße 1 · 96138 Burgebrach · Germany · www.thomann.de