



Wild Wash
132 LED RGB DMX,
132 LED White DMX,
648 LED RGB DMX,
648 LED White DMX

LED floodlight

Musikhaus Thomann
Thomann GmbH
Hans-Thomann-Straße 1
96138 Burgebrach
Germany
Telephone: +49 (0) 9546 9223-0
E-mail: info@thomann.de
Internet: www.thomann.de

17.10.2019, ID: 399664, 399663, 399658, 399662 (V2)

Table of contents

1	General information	5
1.1	Further information.....	6
1.2	Notational conventions.....	7
1.3	Symbols and signal words.....	8
2	Safety instructions	10
3	Features	17
4	Installation	19
5	Starting up	22
6	Connections and controls	25
7	Operating	30
7.1	Starting the device.....	30
7.2	Main menu.....	31
7.3	Menu overview.....	41
7.4	Functions in DMX mode 1ch.....	44
7.5	Functions in DMX mode 2Ch (model versions with white LEDs).....	45

Wild Wash 132 LED RGB DMX, 132 LED White DMX, 648 LED RGB DMX,
648 LED White DMX

7.6	Functions in DMX mode 2Ch1 (model versions with RGB LEDs).....	46
7.7	Functions in DMX mode 2Ch2.....	48
7.8	Functions in DMX mode 3Ch1.....	49
7.9	Functions in DMX mode 3Ch2 (model versions with RGB LEDs).....	50
7.10	Functions in DMX mode 3Ch2 (model versions with white LEDs).....	53
7.11	Functions in DMX mode 3Ch3 (model versions with RGB LEDs).....	54
7.12	Functions in DMX mode 4Ch (model versions with RGB LEDs).....	55
7.13	Functions in DMX mode 5Ch (model versions with white LEDs).....	58
7.14	Functions in DMX mode 6Ch (model versions with RGB LEDs).....	60
7.15	Functions in DMX mode 7Ch (model version with 648 white LEDs).....	62
8	Technical specifications.....	64
9	Plug and connection assignments.....	73
10	Troubleshooting.....	74
11	Cleaning.....	76
12	Protecting the environment.....	77

1 General information

This user manual contains important information on the safe operation of the device. Read and follow all safety notes and all instructions. Save this manual for future reference. Make sure that it is available to all persons using this device. If you sell the device to another user, be sure that they also receive this manual.

Our products and user manuals are subject to a process of continuous development. We therefore reserve the right to make changes without notice. Please refer to the latest version of the user manual which is ready for download under www.thomann.de.

1.1 Further information

On our website (www.thomann.de) you will find lots of further information and details on the following points:

Download	This manual is also available as PDF file for you to download.
Keyword search	Use the search function in the electronic version to find the topics of interest for you quickly.
Online guides	Our online guides provide detailed information on technical basics and terms.
Personal consultation	For personal consultation please contact our technical hotline.
Service	If you have any problems with the device the customer service will gladly assist you.

1.2 Notational conventions

This manual uses the following notational conventions:

Letterings

The letterings for connectors and controls are marked by square brackets and italics.

Examples: *[VOLUME]* control, *[Mono]* button.

Displays

Texts and values displayed on the device are marked by quotation marks and italics.

Examples: *'24ch'*, *'OFF'*.

Cross-references





References to other locations in this manual are identified by an arrow and the specified page number. In the electronic version of the manual, you can click the cross-reference to jump to the specified location.

Example: See [↪](#) *'Cross-references'* on page 7.

1.3 Symbols and signal words

In this section you will find an overview of the meaning of symbols and signal words that are used in this manual.

Signal word	Meaning
DANGER!	This combination of symbol and signal word indicates an immediate dangerous situation that will result in death or serious injury if it is not avoided.
WARNING!	This combination of symbol and signal word indicates a possible dangerous situation that can result in death or serious injury if it is not avoided.
NOTICE!	This combination of symbol and signal word indicates a possible dangerous situation that can result in material and environmental damage if it is not avoided.

Warning signs	Type of danger
	Warning – high-voltage.
	Warning – dangerous optical radiation.
	Warning – suspended load.
	Warning – danger zone.

Wild Wash 132 LED RGB DMX, 132 LED White DMX, 648 LED RGB DMX,
648 LED White DMX

2 Safety instructions

Intended use

This device is intended for use as an electronic lighting effect by means of LED technology. The device is designed for professional use and is not suitable for use in households. Use the device only as described in this user manual. Any other use or use under other operating conditions is considered to be improper and may result in personal injury or property damage. No liability will be assumed for damages resulting from improper use.

This device may be used only by persons with sufficient physical, sensorial, and intellectual abilities and having corresponding knowledge and experience. Other persons may use this device only if they are supervised or instructed by a person who is responsible for their safety.

Extend the life of the device by regular breaks in operation and avoid switching it on and off frequently. This device is not suitable for continuous use.

Safety**DANGER!****Danger for children**

Ensure that plastic bags, packaging, etc. are disposed of properly and are not within reach of babies and young children. Choking hazard!

Ensure that children do not detach any small parts (e.g. knobs or the like) from the unit. They could swallow the pieces and choke!

Never let children unattended use electrical devices.

**DANGER!****Electric shock caused by high voltages inside**

Within the device there are areas where high voltages may be present. Never remove any covers.

There are no user-serviceable parts inside.

Do not use the device if covers, protectors or optical components are missing or damaged.

Wild Wash 132 LED RGB DMX, 132 LED White DMX, 648 LED RGB DMX,
648 LED White DMX



DANGER!

Electric shock caused by short-circuit

Always use proper ready-made insulated mains cabling (power cord) with a protective contact plug. Do not modify the mains cable or the plug. Failure to do so could result in electric shock/death or fire. If in doubt, seek advice from a registered electrician.



WARNING!

Eye damage caused by high light intensity

Never look directly into the light source.



WARNING!

Risk of epileptic shock

Strobe lighting can trigger seizures in photosensitive epilepsy. Sensitive persons should avoid looking at strobe lights.



NOTICE!

Risk of fire

Do not block areas of ventilation. Do not install the device near any direct heat source. Keep the device away from naked flames.

Wild Wash 132 LED RGB DMX, 132 LED White DMX, 648 LED RGB DMX,
648 LED White DMX



NOTICE!

Operating conditions

This device has been designed for indoor use only. To prevent damage, never expose the device to any liquid or moisture. Avoid direct sunlight, heavy dirt, and strong vibrations.

Only operate the device within the ambient conditions specified in the chapter 'Technical specifications' of this user manual. Avoid heavy temperature fluctuations and do not switch the device on immediately after it was exposed to temperature fluctuations (for example after transport at low outside temperatures).

Dust and dirt inside can damage the unit. When operated in harmful ambient conditions (dust, smoke, nicotine, fog, etc.), the unit should be maintained by qualified service personnel at regular intervals to prevent overheating and other malfunction.



NOTICE!

Power supply

Before connecting the device, ensure that the input voltage (AC outlet) matches the voltage rating of the device and that the AC outlet is protected by a residual current circuit breaker. Failure to do so could result in damage to the device and possibly injure the user.

Unplug the device before electrical storms occur and when it is unused for long periods of time to reduce the risk of electric shock or fire.



NOTICE!

Possible damage due to installation of a wrong fuse

The use of different types of fuses can cause serious damage to the unit. Fire hazard!

Only fuses of the same type may be used.



NOTICE!

Possible staining

The plasticiser contained in the rubber feet of this product may possibly react with the coating of your parquet, linoleum, laminate or PVC floor and after some time cause permanent dark stains.

In case of doubt, do not put the rubber feet directly on the floor, but use felt-pad floor protectors or a carpet.



NOTICE!

Risk of overheating

The distance between light output and the illuminated surface must be more than 1.5 m (19.7in).

Provide sufficient ventilation.

The ambient temperature must always be below 104 °F (40 °C).

3 Features

The LED floodlight is particularly suitable for lighting applications in clubs and discotheques, on rock stages, in theatres and musicals. It can also be used for effect lighting of stage backgrounds and as blinder.

Special features of the device:

- Equipped with SMD LEDs with 0.2 W power consumption each, depending on the model version:
 - Stairville Wild Wash 132 LED RGB DMX (item no. 399664): 132 tricolour LEDs (RGB)
 - Stairville Wild Wash 132 LED White DMX (item no. 399663): 132 cold white LEDs
 - Stairville Wild Wash 648 LED RGB DMX (item no. 399658): 648 tricolour LEDs (RGB)
 - Stairville Wild Wash 648 LED White DMX (item no. 399662): 648 cold white LEDs
- Control via DMX (different modes depending on the model version) and via buttons and display on the unit
- Built-in automatic show programmes
- Sound control
- Master / slave mode
- Robust metal housing with compact design
- Versatile installation and mounting options with the included two-piece mounting bracket

Wild Wash 132 LED RGB DMX, 132 LED White DMX, 648 LED RGB DMX,
648 LED White DMX

For technological reasons, the light output of LEDs decreases over their lifetime. This effect increases with higher operating temperature. You can extend the service life of the illuminants by providing adequate ventilation and operating the LEDs with the lowest possible brightness.

4 Installation

Unpack and check carefully there is no transportation damage before using the unit. Keep the equipment packaging. To fully protect the product against vibration, dust and moisture during transportation or storage use the original packaging or your own packaging material suitable for transport or storage, respectively.

You can install the device standing or hanging. When in use, the device must be mounted at a solid surface or clamped to an approved truss.

Work from a stable platform whenever you install or move the device or when you perform any kind of maintenance. Block access under the work area.



WARNING!

Risk of injury caused by falling objects

Make sure that the installation complies with the standards and rules that apply in your country. Always secure the device with a secondary safety attachment, such as a safety cable or a safety chain.

Wild Wash 132 LED RGB DMX, 132 LED White DMX, 648 LED RGB DMX,
648 LED White DMX



NOTICE!

Risk of overheating

The distance between light output and the illuminated surface must be more than 1.5 m (19.7in).

Provide sufficient ventilation.

The ambient temperature must always be below 40 °C (104 °F).



NOTICE!

Possible data transmission errors

For error-free operation make use of dedicated DMX cables and do not use ordinary microphone cables.

Never connect the DMX input or output to audio devices such as mixers or amplifiers.



Please note that this device must not be connected to a dimmer.

Wild Wash 132 LED RGB DMX, 132 LED White DMX, 648 LED RGB DMX,
648 LED White DMX

5 Starting up

Create all connections while the device is off. Use the shortest possible high-quality cables for all connections. Take care when running the cables to prevent tripping hazards.

Connections in DMX mode

Connect the DMX input of the device to the DMX output of a DMX controller or another DMX device. Connect the output of the first DMX device to the input of the second one, and so on to form a daisy chain. Always ensure that the output of the last DMX device in the daisy chain is terminated with a resistor ($110\ \Omega$, $\frac{1}{4}\ \text{W}$).

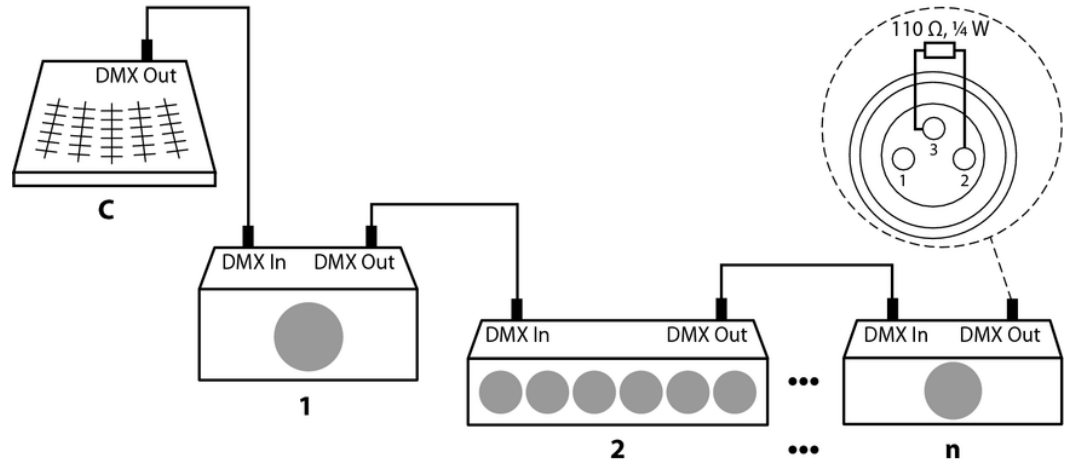

Wild Wash 132 LED RGB DMX, 132 LED White DMX, 648 LED RGB DMX,
648 LED White DMX

Connections in master/slave mode

When you configure a group of devices in master/slave mode, the first unit will control the other units for an automatic, sound-activated, synchronized show. This function is ideal when you want to start a show immediately. Connect the DMX output of the master device to the DMX input of the first slave device. Then connect the DMX output of the first slave device to the DMX input of the second slave device and so on.

6 Connections and controls

Stairville Wild Wash 132 LED
 RGB DMX (item no. 399664)

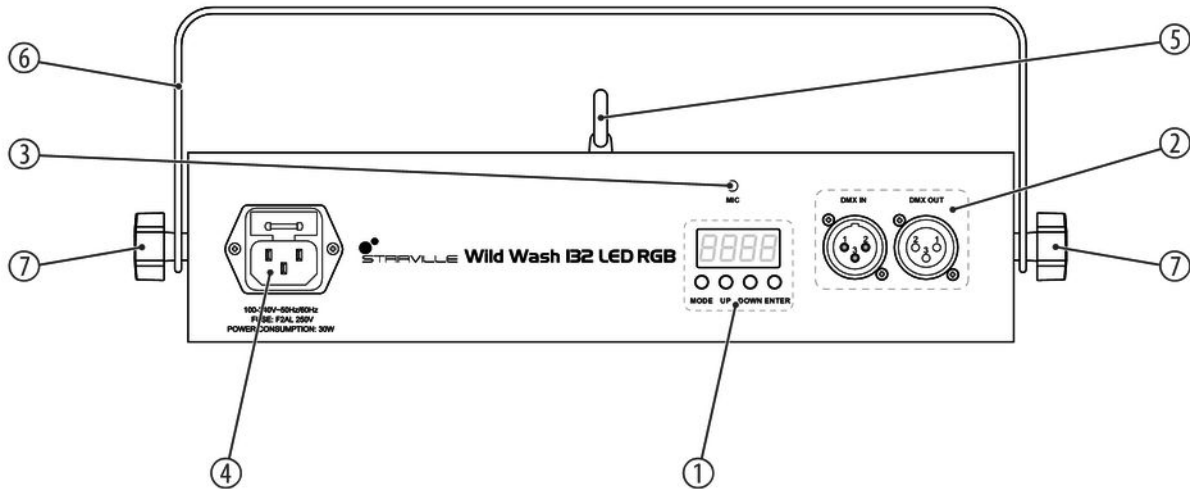

Wild Wash 132 LED RGB DMX, 132 LED White DMX, 648 LED RGB DMX,
 648 LED White DMX

Stairville Wild Wash 132 LED
White DMX (item no. 399663)

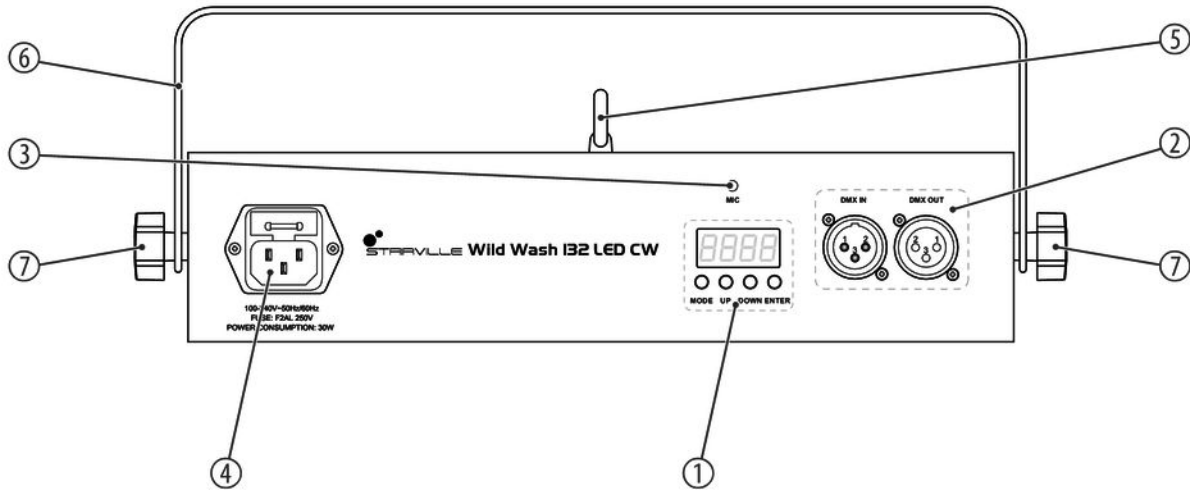

**Stairville Wild Wash 648 LED
RGB DMX (item no. 399658)**

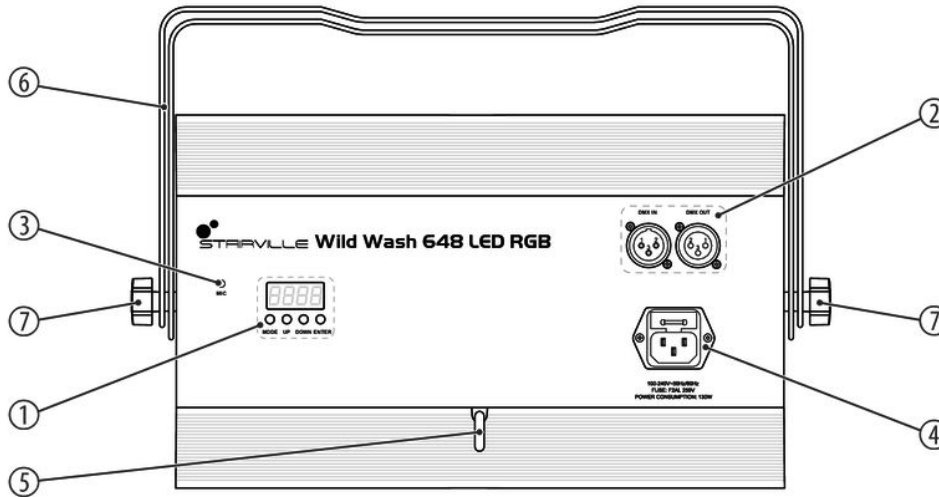

Wild Wash 132 LED RGB DMX, 132 LED White DMX, 648 LED RGB DMX,
648 LED White DMX

Stairville Wild Wash 648 LED
White DMX (item no. 399662)

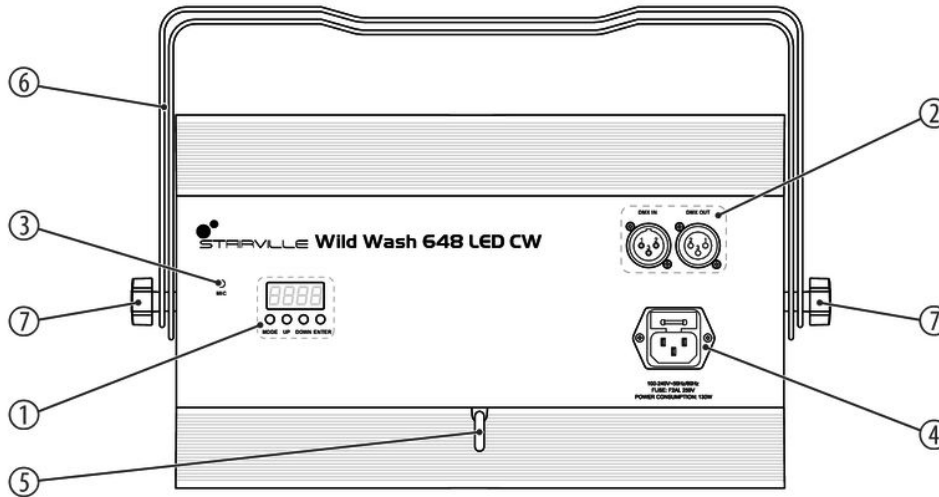

1	Display and control buttons: <i>[MENU]</i> : Activates the main menu and toggles between menu items. <i>[UP]</i> : Increases the displayed value by one <i>[DOWN]</i> : Decreases the displayed value by one <i>[ENTER]</i> : Chooses between the options of the selected mode
2	<i>[DMX IN]</i> : DMX input socket <i>[DMX OUT]</i> : DMX output socket
3	<i>[MIC]</i> Microphone for sound control
4	IEC chassis plug for the mains cable with fuse holder
5	Safety cable eyelet.
6	Two-piece bracket for hanging or installation and for securing the safety cable
7	Locking screw for fixing the spotlight

Wild Wash 132 LED RGB DMX, 132 LED White DMX, 648 LED RGB DMX,
648 LED White DMX

7 Operating

7.1 Starting the device

Connect the device to the power supply to start operation. After a few seconds, the display indicates that a reset is in progress. The device is then ready for use. The display shows the operating mode that was selected when the unit was last powered off.

7.2 Main menu

Operating mode 'DMX'

This setting is only relevant if the device is controlled via a DMX controller.

Press *[MODE]* repeatedly until one of the available DMX modes appears in the display and press *[ENTER]*. Use *[UP]* and *[DOWN]* to select the desired DMX mode and press *[ENTER]*.

The following table shows the DMX modes available depending on the version.

Model version	Available DMX modes
Stairville Wild Wash 132 LED RGB DMX (item no. 399664)	1CH, 2CH1, 2CH2, 3CH1, 3CH2, 3CH3, 4CH, 6CH
Stairville Wild Wash 132 LED White DMX (item no. 399663)	1Ch, 2CH, 3CH1, 3CH2
Stairville Wild Wash 648 LED RGB DMX (item no. 399658)	1CH, 2CH1, 2CH2, 3CH1, 3CH2, 3CH3, 4CH, 6CH
Stairville Wild Wash 648 LED White DMX (item no. 399662)	1CH, 2CH, 3CH, 5CH, 7CH

Wild Wash 132 LED RGB DMX, 132 LED White DMX, 648 LED RGB DMX,
648 LED White DMX

DMX address

This setting is only relevant if the device is controlled via a DMX controller.

Press *[MODE]* repeatedly until the currently set DMX address appears in the display ('Axxx') and press *[ENTER]*. Use *[UP]* and *[DOWN]* to select the desired DMX address between 1 ('A001') and 512 ('A512') and press *[ENTER]*.

Operating mode 'Manual control' (white LED model versions)

This setting is only relevant if the device is not controlled via a DMX controller and not working as slave in a master / slave configuration. In this mode, the brightness of the white LEDs can be adjusted and a Strobe effect can be engaged.

Press *[MODE]* repeatedly until 'C000' appears in the display and press *[ENTER]*. Use *[UP]* and *[DOWN]* to select the menu item 'C1xx' for brightness or the menu item 'CFxx' for the Strobe effect and press *[ENTER]*.

To adjust the brightness, use *[UP]* and *[DOWN]* to select a value between 'C101' (minimum brightness) and 'C199' (maximum brightness) or 'C100' (blackout, LEDs off) and press *[ENTER]*.

To adjust the Strobe effect, use *[UP]* and *[DOWN]* to select a value between 'CF01' (Strobe frequency approx. 1 Hz) and 'CF99' (Strobe frequency approx. 30 Hz) or 'CF00' (continuous light, no Strobe effect) and press *[ENTER]*.

Operating mode 'Manual control' (RGB LED model versions)

This setting is only relevant if the device is not controlled via a DMX controller and not working as slave in a master / slave configuration. In this mode, the intensity of the LEDs can be adjusted per colour and a Strobe effect can be engaged.

Press *[MODE]* repeatedly until 'C1xx' appears in the display and press *[ENTER]*. Use *[UP]* and *[DOWN]* to select the menu item 'C1xx', 'C2xx' or 'C3xx' for brightness of the red, green or blue LEDs or the menu item 'CFxx' for the Strobe effect and press *[ENTER]*.

To adjust the Strobe effect, use *[UP]* and *[DOWN]* to select a value between 'CF01' (Strobe frequency approx. 1 Hz) and 'CF99' (Strobe frequency approx. 30 Hz) or 'CF00' (continuous light, no Strobe effect) and press *[ENTER]*.

Operating mode 'Colour macros' (RGB LED model versions)

This setting is only relevant if the device is not controlled via a DMX controller and not working as slave in a master / slave configuration. In this mode, one of the three primary colours or a predefined mixed colour can be selected.

Press *[MODE]* repeatedly until 'CMxx' appears in the display and press *[ENTER]*. Use *[UP]* and *[DOWN]* to select a value between 'CM01' and 'CM015' and press *[ENTER]*. The table below shows the colour assignment.

Setting	Colour
CM01	Red
CM02	Amber
CM03	Warm yellow
CM04	Yellow
CM05	Green
CM06	Turquoise
CM07	Cyan
CM08	Blue

Setting	Colour
CM09	Lavender
CM10	Mauve
CM11	Magenta
CM12	Pink
CM13	Warm white
CM14	White
CM15	Cold white

Wild Wash 132 LED RGB DMX, 132 LED White DMX, 648 LED RGB DMX,
648 LED White DMX

Operating mode 'Automatic colour change' (RGB LED model versions)

This setting is only relevant if the device is not controlled via a DMX controller and not working as slave in a master / slave configuration. In this mode, the colours are changed at freely selectable speed, a Strobe effect can be engaged.

Press *[MODE]* repeatedly until 'JUxx' appears in the display and press *[ENTER]*. Use *[UP]* and *[DOWN]* to select the menu item 'JUxx' for colour change speed or the menu item 'JFxx' for the Strobe effect.

For colour change speed, use *[UP]* and *[DOWN]* to select a value between 'JU00' (minimum speed) and 'JU99' (maximum speed) and press *[ENTER]*.

To adjust the Strobe effect, use *[UP]* and *[DOWN]* to select a value between 'JF01' (flash frequency approx. 1 Hz) and 'CF99' (flash frequency approx. 30 Hz) or 'CF00' (continuous light, no Strobe effect) and press *[ENTER]*.

Operating mode 'Fading' (white LED model versions)

This setting is only relevant if the device is not controlled via a DMX controller and not working as slave in a master / slave configuration. In this mode, the LEDs will gradually fade in with a freely selectable speed from blackout to maximum brightness and reverse, a Strobe effect can be engaged.

Press *[MODE]* repeatedly until 'FA00' appears in the display and press *[ENTER]*. Use *[UP]* and *[DOWN]* to select the menu item 'FAxx' for the fading speed or the menu item 'FFxx' for the Strobe effect and press *[ENTER]*.

To adjust the fading speed, use *[UP]* and *[DOWN]* to select a value between 'FA01' (minimum speed) and 'FA99' (maximum speed) and press *[ENTER]*.

To adjust the Strobe effect, use *[UP]* and *[DOWN]* to select a value between 'FF01' (flash frequency approx. 1 Hz) and 'FF99' (flash frequency approx. 30 Hz) or 'FF00' (continuous light, no Strobe effect) and press *[ENTER]*.

Operating mode 'Fading' (RGB LED model versions)

This setting is only relevant if the device is not controlled via a DMX controller and not working as slave in a master / slave configuration. In this mode, the LEDs gradually change between the available colours at freely selectable speed, a Strobe effect can be engaged.

Press *[MODE]* repeatedly until 'FA00' appears in the display and press *[ENTER]*. Use *[UP]* and *[DOWN]* to select the menu item 'FAxx' for the fading speed or the menu item 'FAxx' for the Strobe effect and press *[ENTER]*.

To adjust the fading speed, use *[UP]* and *[DOWN]* to select a value between 'FA01' (minimum speed) and 'FA99' (maximum speed) or 'C100' and press *[ENTER]*.

To adjust the Strobe effect, use *[UP]* and *[DOWN]* to select a value between 'FF01' (flash frequency approx. 1 Hz) and 'FF99' (flash frequency approx. 30 Hz) or 'FF00' (continuous light, no Strobe effect) and press *[ENTER]*.

Operating mode 'Automatic show' (white LED model versions)

This setting is only relevant if the device is not controlled via a DMX controller and not working as slave in a master / slave configuration. In this mode, the LEDs will gradually fade in with a freely selectable speed from blackout to maximum brightness and reverse, the Strobe effect is automatically engaged in regular intervals.

Press *[MODE]* repeatedly until 'AUTO' appears in the display and press *[ENTER]*. For effect speed, use *[UP]* and *[DOWN]* to select a value between 'AU00' (minimum speed) and 'AU99' (maximum speed) and press *[ENTER]*.

Operating mode 'Automatic show' (RGB LED model versions)

This setting is only relevant if the device is not controlled via a DMX controller and not working as slave in a master / slave configuration. In this mode, the LEDs gradually change at freely selectable speed between the available colours, the Strobe effect is automatically engaged in regular intervals.

Press *[MODE]* repeatedly until 'AUTO' appears in the display and press *[ENTER]*. For effect speed, use *[UP]* and *[DOWN]* to select a value between 'AU00' (minimum speed) and 'AU99' (maximum speed) and press *[ENTER]*.

Operating mode 'Sound control'

This setting is only relevant if the device is not controlled via a DMX controller and not working as slave in a master / slave configuration. In this mode, the LEDs are controlled via the built-in microphone.

Press *[MODE]* repeatedly until 'SOUN' appears in the display and press *[ENTER]*. For microphone sensitivity, use *[UP]* and *[DOWN]* to select a value between 'SO00' (minimum sensitivity) and 'SO99' (maximum sensitivity) and press *[ENTER]*.

Operating mode 'Slave'

This setting is only relevant if the device is not controlled via a DMX controller and working as slave in a master / slave configuration. Master and slave devices are connected to each other via a DMX cable, the master device is in one of the operating modes 'Manual control', 'Fading', 'Automatic show' or 'Sound control'.

Press *[MODE]* repeatedly until 'SLAV' appears in the display and press *[ENTER]*. The slave device now copies exactly the actions of the master device.

7.3 Menu overview

Model version with 132 white LEDs.

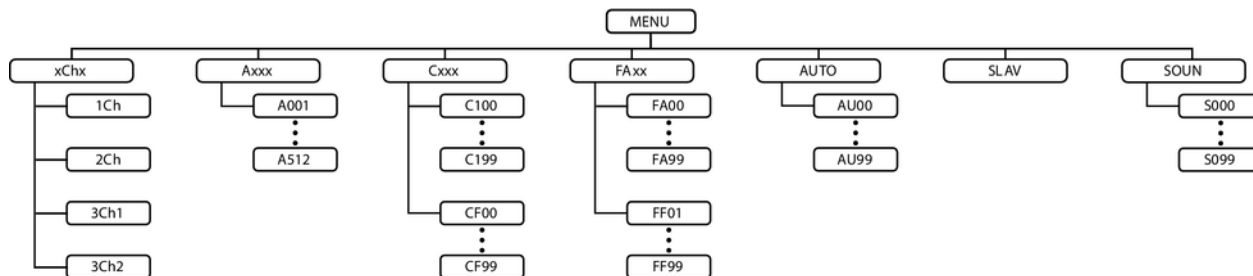

Wild Wash 132 LED RGB DMX, 132 LED White DMX, 648 LED RGB DMX,
648 LED White DMX

Model version with 648 white LEDs.

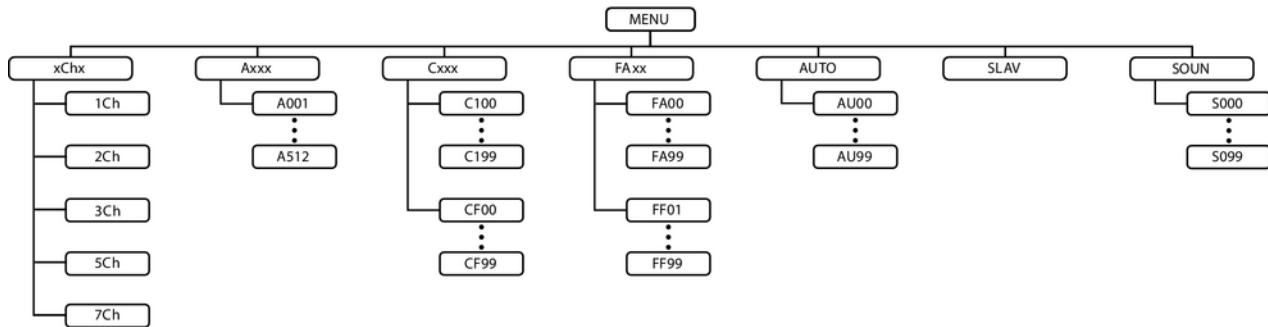

Model versions with RGB LEDs

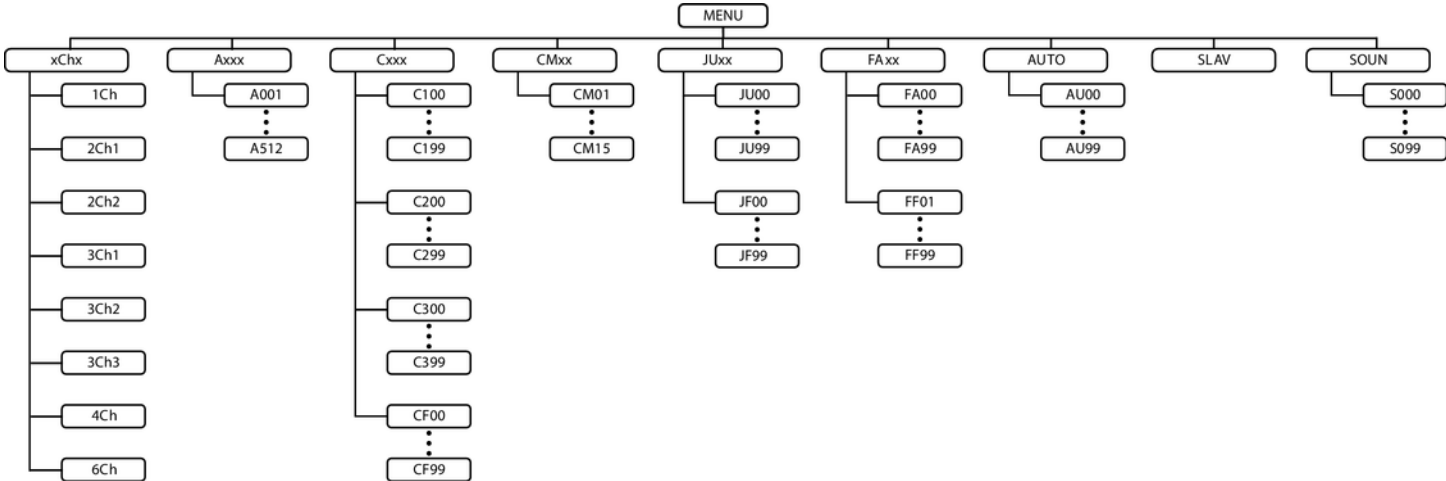

Wild Wash 132 LED RGB DMX, 132 LED White DMX, 648 LED RGB DMX, 648 LED White DMX

7.4 Functions in DMX mode 1ch

Channel	Value	Function
1	Strobe	
	0 ... 10	LEDs off (blackout)
	11 ... 255	Strobe effect, speed increasing from approx. 0 Hz to 30 Hz

7.5 Functions in DMX mode 2Ch (model versions with white LEDs)

Channel	Value	Function
1	0 ... 255	Dimmer (0 % to 100 %)
2	Strobe	
	0 ... 5	LEDs on
	6 ... 10	LEDs off (blackout)
	11 ... 250	Strobe effect, speed increasing from approx. 0 Hz to 30 Hz
	251 ... 255	LEDs on

Wild Wash 132 LED RGB DMX, 132 LED White DMX, 648 LED RGB DMX,
648 LED White DMX

7.6 Functions in DMX mode 2Ch1 (model versions with RGB LEDs)

Channel	Value	Function
1	0 ... 255	Dimmer (0 % to 100 %)
2	Colour macro	
	0 ... 5	LEDs off (blackout)
	6 ... 13	Red
	14 ... 21	Amber
	22 ... 29	Warm yellow
	30 ... 37	Yellow
	38 ... 45	Green
	46 ... 53	Turquoise
	54 ... 61	Cyan
	62 ... 69	Blue

Channel	Value	Function
	70 ... 77	Lavender
	78 ... 85	Mauve
	86 ... 93	Magenta
	94 ... 101	Pink
	102 ... 109	Warm white
	110 ... 117	White
	118 ... 125	Cold white
	126 ... 128	Ending colour change
	129 ... 192	Colour change, increasing speed
	193 ... 255	Gradual colour change, increasing speed

Wild Wash 132 LED RGB DMX, 132 LED White DMX, 648 LED RGB DMX,
648 LED White DMX

7.7 Functions in DMX mode 2Ch2

Channel	Value	Function
1	0 ... 255	Dimmer (0 % to 100 %)
2	Strobe	
	0 ... 5	LEDs on
	6 ... 10	LEDs off (blackout)
	11 ... 250	Strobe effect, speed increasing from approx. 0 Hz to 30 Hz
	251 ... 255	LEDs on

7.8 Functions in DMX mode 3Ch1

Channel	Value	Function
1	0 ... 255	Dimmer (0 % to 100 %)
2	Strobe	
	0 ... 5	LEDs on
	6 ... 10	LEDs off (blackout)
	11 ... 250	Strobe effect, speed increasing from approx. 0 Hz to 30 Hz
	251 ... 255	LEDs on
3	Flash impulse	
	0 ... 255	Flash impulse duration, increasing from 0 ms to 510 ms

Wild Wash 132 LED RGB DMX, 132 LED White DMX, 648 LED RGB DMX,
648 LED White DMX

7.9 Functions in DMX mode 3Ch2 (model versions with RGB LEDs)

Channel	Value	Function
1	0 ... 255	Dimmer (0 % to 100 %)
2	Strobe	
	0 ... 5	LEDs on
	6 ... 10	LEDs off (blackout)
	11 ... 250	Strobe effect, speed increasing from approx. 0 Hz to 30 Hz
	251 ... 255	LEDs on
3	Colour macro	
	0 ... 5	LEDs off (blackout)
	6 ... 13	Red
	14 ... 21	Amber
	22 ... 29	Warm yellow

Channel	Value	Function
	30 ... 37	Yellow
	38 ... 45	Green
	46 ... 53	Turquoise
	54 ... 61	Cyan
	62 ... 69	Blue
	70 ... 77	Lavender
	78 ... 85	Mauve
	86 ... 93	Magenta
	94 ... 101	Pink
	102 ... 109	Warm white
	110 ... 117	White
	118 ... 125	Cold white
	126 ... 128	Ending colour change

Wild Wash 132 LED RGB DMX, 132 LED White DMX, 648 LED RGB DMX,
648 LED White DMX

Channel	Value	Function
	129 ... 192	Colour change, increasing speed
	193 ... 255	Gradual colour change, increasing speed

7.10 Functions in DMX mode 3Ch2 (model versions with white LEDs)

Channel	Value	Function
1	0 ... 255	Dimmer (0 % to 100 %)
2	Strobe	
	0 ... 5	LEDs on, brightness controlled by channel 1
	6 ... 10	LEDs off (blackout)
	11 ... 33	Random impulses, increasing speed
	34 ... 56	Randomly increasing brightness, increasing speed
	57 ... 79	Randomly decreasing brightness, increasing speed
	80 ... 102	Random Strobe effect, increasing speed
	103 ... 127	Interrupt effect, 5 s to 1 s
	128 ... 250	Strobe effect, speed increasing from approx. 0 Hz to 30 Hz
	251 ... 255	LEDs on, brightness controlled by channel 1

Wild Wash 132 LED RGB DMX, 132 LED White DMX, 648 LED RGB DMX,
648 LED White DMX

Channel	Value	Function
3	Sound control	
	0 ... 5	Sound control off
	6 ... 255	Sound control on, increasing sensitivity

7.11 Functions in DMX mode 3Ch3 (model versions with RGB LEDs)

Channel	Value	Function
1	0 ... 255	Intensity red (0 % to 100 %)
2	0 ... 255	Intensity green (0 % to 100 %)
3	0 ... 255	Intensity blue (0 % to 100 %)

7.12 Functions in DMX mode 4Ch (model versions with RGB LEDs)

Channel	Value	Function
1	0 ... 255	Dimmer (0 % to 100 %)
2	Strobe	
	0 ... 5	LEDs on, brightness controlled by channel 1
	6 ... 10	LEDs off (blackout)
	11 ... 33	Random impulses, increasing speed
	34 ... 56	Randomly increasing brightness, increasing speed
	57 ... 79	Randomly decreasing brightness, increasing speed
	80 ... 102	Random Strobe effect, increasing speed
	103 ... 127	Interrupt effect, 5 s to 1 s
	128 ... 250	Strobe effect, speed increasing from approx. 0 Hz to 30 Hz
	251 ... 255	LEDs on, brightness controlled by channel 1

Wild Wash 132 LED RGB DMX, 132 LED White DMX, 648 LED RGB DMX,
648 LED White DMX

Channel	Value	Function
3	Colour macro	
	0 ... 5	LEDs off (blackout)
	6 ... 13	Red
	14 ... 21	Amber
	22 ... 29	Warm yellow
	30 ... 37	Yellow
	38 ... 45	Green
	46 ... 53	Turquoise
	54 ... 61	Cyan
	62 ... 69	Blue
	70 ... 77	Lavender
	78 ... 85	Mauve
86 ... 93	Magenta	

Channel	Value	Function
	94 ... 101	Pink
	102 ... 109	Warm white
	110 ... 117	White
	118 ... 125	Cold white
	126 ... 128	Ending colour change
	129 ... 192	Colour change, increasing speed
	193 ... 255	Gradual colour change, increasing speed
4	Sound control	
	0 ... 5	Sound control off
	6 ... 255	Sound control on, increasing sensitivity

Wild Wash 132 LED RGB DMX, 132 LED White DMX, 648 LED RGB DMX,
648 LED White DMX

7.13 Functions in DMX mode 5Ch (model versions with white LEDs)

Channel	Value	Function
1	0 ... 255	Dimmer (0 % to 100 %)
2	Strobe	
	0 ... 5	LEDs on, brightness controlled by channel 1
	6 ... 10	LEDs off (blackout)
	11 ... 33	Random impulses, increasing speed
	34 ... 56	Randomly increasing brightness, increasing speed
	57 ... 79	Randomly decreasing brightness, increasing speed
	80 ... 102	Random Strobe effect, increasing speed
	103 ... 127	Interrupt effect, 5 s to 1 s
	128 ... 250	Strobe effect, speed increasing from approx. 0 Hz to 30 Hz
	251 ... 255	LEDs on, brightness controlled by channel 1

Channel	Value	Function
3	Strobe programmes	
	0 ... 5	No function
	11 ... 255	Automatic Strobe programmes with alternating segments
4	Running speed	
	11 ... 255	Automatic Strobe programme speed, increasing if channel 5 = 0...5)
5	Sound control	
	0 ... 5	Sound control off
	6 ... 255	Sound control on, increasing sensitivity

Wild Wash 132 LED RGB DMX, 132 LED White DMX, 648 LED RGB DMX,
648 LED White DMX

7.14 Functions in DMX mode 6Ch (model versions with RGB LEDs)

Channel	Value	Function
1	0 ... 255	Dimmer (0 % to 100 %)
2	Strobe	
	0 ... 5	LEDs on, brightness controlled by channel 1
	6 ... 10	LEDs off (blackout)
	11 ... 33	Random impulses, increasing speed
	34 ... 56	Randomly increasing brightness, increasing speed
	57 ... 79	Randomly decreasing brightness, increasing speed
	80 ... 102	Random Strobe effect, increasing speed
	103 ... 127	Interrupt effect, 5 s to 1 s
	128 ... 250	Strobe effect, speed increasing from approx. 0 Hz to 30 Hz
	251 ... 255	LEDs on, brightness controlled by channel 1

Channel	Value	Function
3	0 ... 255	Intensity red (0 % to 100 %)
4	0 ... 255	Intensity green (0 % to 100 %)
5	0 ... 255	Intensity blue (0 % to 100 %)
6	Sound control	
	0 ... 5	Sound control off
	6 ... 255	Sound control on, increasing sensitivity

Wild Wash 132 LED RGB DMX, 132 LED White DMX, 648 LED RGB DMX,
648 LED White DMX

7.15 Functions in DMX mode 7Ch (model version with 648 white LEDs)

Channel	Value	Function
1	0 ... 255	Dimmer (0 % to 100 %)
2	Strobe	
	0 ... 5	LEDs on
	6 ... 10	LEDs off (blackout)
	11 ... 250	Strobe effect, speed increasing from approx. 0 Hz to 30 Hz
	251 ... 255	LEDs on
3	Flash impulse	
	0 ... 255	Flash impulse duration, increasing from 0 ms to 510 ms
4	0 ... 255	Brightness of LED segment 1 (0 % to 100 %)
5	0 ... 255	Brightness of LED segment 2 (0 % to 100 %)

Channel	Value	Function
6	0 ... 255	Brightness of LED segment 3 (0 % to 100 %)
7	0 ... 255	Brightness of LED segment 4 (0 % to 100 %)

Wild Wash 132 LED RGB DMX, 132 LED White DMX, 648 LED RGB DMX,
648 LED White DMX

8 Technical specifications

Stairville Wild Wash 132 LED RGB DMX (item no. 399664)

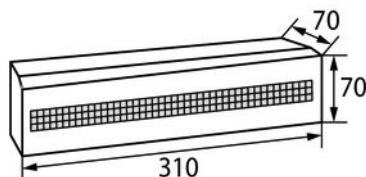

Light source	132 × tricolour SMD LEDs, 0.2 W each	
Optical properties	Beam angle	approx. 75°
Control	DMX, buttons and display on the unit	
Number of DMX channels	1, 2, 3, 4 or 6	
Input connections	Power supply	IEC chassis plug C14
	DMX control	XLR chassis socket, 3-pin
Output connections	DMX control	XLR chassis socket, 3-pin
Power consumption	30 W	
Supply voltage	100 – 240 V ~ 50/60 Hz	
Fuse	5 mm × 20 mm, 2 A, 250 V, fast-acting	

Degree of protection	IP20	
Mounting options	Hanging, standing	
Dimensions (W × H × D)	310 mm × 70 mm × 70 mm	
Weight	1.05 kg	
Ambient conditions	Temperature range	0 °C...40 °C
	Relative humidity	50 %, non-condensing

Wild Wash 132 LED RGB DMX, 132 LED White DMX, 648 LED RGB DMX,
648 LED White DMX

**Stairville Wild Wash 132 LED
White DMX (item no. 399663)**

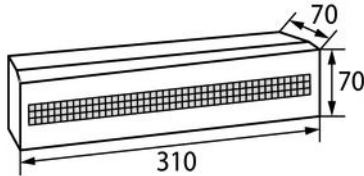

Light source	132 × SMD LEDs, cold white, 0.2 W each	
Light source properties	Colour temperature	6000 K
	Colour rendering index	CRI 75
Optical properties	Beam angle	approx. 75°
Control	DMX, buttons and display on the unit	
Number of DMX channels	1, 2 or 3	
Input connections	Power supply	IEC chassis plug C14
	DMX control	XLR chassis socket, 3-pin
Output connections	DMX control	XLR chassis socket, 3-pin
Power consumption	30 W	
Supply voltage	100 – 240 V ~ 50/60 Hz	
Fuse	5 mm × 20 mm, 2 A, 250 V, fast-acting	

Degree of protection	IP20	
Mounting options	Hanging, standing	
Dimensions (W × H × D)	310 mm × 70 mm × 70 mm	
Weight	1.05 kg	
Ambient conditions	Temperature range	0 °C...40 °C
	Relative humidity	50 %, non-condensing

Wild Wash 132 LED RGB DMX, 132 LED White DMX, 648 LED RGB DMX,
648 LED White DMX

**Stairville Wild Wash 648 LED
RGB DMX (item no. 399658)**

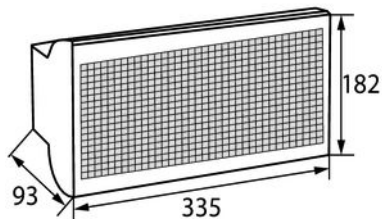

Light source	648 × tricolour SMD LEDs, 0.2 W each	
Optical properties	Beam angle	approx. 75°
Control	DMX, buttons and display on the unit	
Number of DMX channels	1, 2, 3, 5 or 7	
Input connections	Power supply	IEC chassis plug C14
	DMX control	XLR chassis socket, 3-pin
Output connections	DMX control	XLR chassis socket, 3-pin
Power consumption	130 W	
Supply voltage	100 – 240 V ~ 50/60 Hz	
Fuse	5 mm × 20 mm, 2 A, 250 V, fast-acting	
Degree of protection	IP20	
Mounting options	Hanging, standing	

Dimensions (W × H × D)	335 mm × 182 mm × 93 mm	
Weight	3.25 kg	
Ambient conditions	Temperature range	0 °C...40 °C
	Relative humidity	50 %, non-condensing

Wild Wash 132 LED RGB DMX, 132 LED White DMX, 648 LED RGB DMX,
648 LED White DMX

**Stairville Wild Wash 648 LED
White DMX (item no. 399662)**

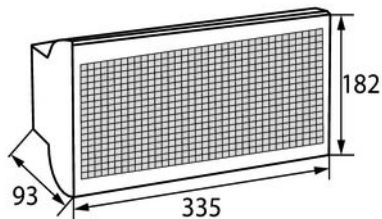

Light source	648 × SMD LEDs, cold white, 0.2 W each	
Light source properties	Colour temperature	600 K
	Colour rendering index	CRI 70
Optical properties	Beam angle	approx. 75°
Control	DMX, buttons and display on the unit	
Number of DMX channels	1, 2, 3, 4 or 6	
Input connections	Power supply	IEC chassis plug C14
	DMX control	XLR chassis socket, 3-pin
Output connections	DMX control	XLR chassis socket, 3-pin
Power consumption	130 W	
Supply voltage	100 – 240 V ~ 50/60 Hz	
Fuse	5 mm × 20 mm, 2 A, 250 V, fast-acting	

Degree of protection	IP20	
Mounting options	Hanging, standing	
Dimensions (W × H × D)	335 mm × 182 mm × 93 mm	
Weight	3.25 kg	
Ambient conditions	Temperature range	0 °C...40 °C
	Relative humidity	50 %, non-condensing

Wild Wash 132 LED RGB DMX, 132 LED White DMX, 648 LED RGB DMX,
648 LED White DMX

Further information

Suitable for outdoor use	No
LED type	SMD
Floor housing	No
Fanless	No
Remote control	Not possible
wireless DMX	No
Housing colour	Black

9 Plug and connection assignments

Introduction

This chapter will help you select the right cables and plugs to connect your valuable equipment so that a perfect light experience is guaranteed.

Please take our tips, because especially in 'Sound & Light' caution is indicated: Even if a plug fits into a socket, the result of an incorrect connection may be a destroyed DMX controller, a short circuit or 'just' a not working light show!

DMX connections

The unit offers a 3-pin XLR socket for DMX output and a 3-pin XLR plug for DMX input. Please refer to the drawing and table below for the pin assignment of a suitable XLR plug.



Pin	Configuration
1	Ground, shielding
2	Signal inverted (DMX-, 'cold signal')
3	Signal (DMX+, 'hot signal')

Wild Wash 132 LED RGB DMX, 132 LED White DMX, 648 LED RGB DMX, 648 LED White DMX

10 Troubleshooting



NOTICE!

Possible data transmission errors

For error-free operation make use of dedicated DMX cables and do not use ordinary microphone cables.

Never connect the DMX input or output to audio devices such as mixers or amplifiers.

In the following we list a few common problems that may occur during operation. We give you some suggestions for easy troubleshooting:

Symptom	Remedy
The unit does not work, no light, the display is dark	Check the mains connection and the main fuse.
Apparently no function despite proper power supply	Check if the unit is in DMX mode or in 'slave' mode. If so, check the unit in another mode.
No response to the DMX controller	1. Check whether the DMX controller is switched on. Check the DMX connectors and cables for proper connection.
	2. Check the address settings and the DMX polarity.
	3. Try using another DMX controller.
	4. Check whether the DMX cables run near or parallel to high-voltage cables that may cause damage or interference to a DMX interface circuit.

If the procedures recommended above do not succeed, please contact our Service Center. You can find the contact information at www.thomann.de.

Wild Wash 132 LED RGB DMX, 132 LED White DMX, 648 LED RGB DMX,
648 LED White DMX

11 Cleaning

Optical lenses

Clean the optical lenses, that are accessible from the outside, regularly in order to optimize the light output. The frequency of cleaning depends on the operating environment: wet, smoky or particularly dirty surroundings can cause more accumulation of dirt on the optics of the device.

- Clean with a soft cloth using our lamp and lens cleaner (item no. 280122).
- Always dry the parts carefully.

Fan grids

The fan grids of the device must be cleaned of any contamination, such as dust, etc. on a regular basis. Before cleaning, switch off the device and disconnect mains-operated devices from the mains. Only use pH-neutral, solvent-free and non-abrasive cleaning agents. Clean the unit with a slightly damp lint-free cloth.

12 Protecting the environment

Disposal of the packaging material



For the transport and protective packaging, environmentally friendly materials have been chosen that can be supplied to normal recycling.

Ensure that plastic bags, packaging, etc. are properly disposed of.

Do not just dispose of these materials with your normal household waste, but make sure that they are collected for recycling. Please follow the notes and markings on the packaging.

Disposal of your old device



This product is subject to the European Waste Electrical and Electronic Equipment Directive (WEEE) in its currently valid version. Do not dispose with your normal household waste.

Dispose of this device through an approved waste disposal firm or through your local waste facility. When discarding the device, comply with the rules and regulations that apply in your country. If in doubt, consult your local waste disposal facility.

Wild Wash 132 LED RGB DMX, 132 LED White DMX, 648 LED RGB DMX,
648 LED White DMX



