

# HITMAN

HD-7 Sonic  
e-drum set



Musikhaus Thomann  
Thomann GmbH  
Hans-Thomann-Straße 1  
96138 Burgebrach  
Germany  
Telephone: +49 (0) 9546 9223-0  
E-mail: [info@thomann.de](mailto:info@thomann.de)  
Internet: [www.thomann.de](http://www.thomann.de)

24.05.2019, ID: 429325 (V2)

---

## Table of contents

<b>1</b>	<b>General information</b> .....	<b>4</b>
	1.1 Further information.....	4
	1.2 Notational conventions.....	4
	1.3 Symbols and signal words.....	5
<b>2</b>	<b>Safety instructions</b> .....	<b>6</b>
<b>3</b>	<b>Features</b> .....	<b>8</b>
<b>4</b>	<b>Scope of delivery</b> .....	<b>9</b>
<b>5</b>	<b>Assembly</b> .....	<b>10</b>
<b>6</b>	<b>Drum seat assembly (option)</b> .....	<b>14</b>
<b>7</b>	<b>Installation</b> .....	<b>15</b>
<b>8</b>	<b>Connections and controls</b> .....	<b>17</b>
<b>9</b>	<b>Operating</b> .....	<b>20</b>
	9.1 Functions.....	20
	9.2 Drum kits.....	20
	9.3 Setup.....	24
	9.4 Songs.....	26
	9.5 Metronome.....	27
	9.6 Tempo.....	28
	9.7 Record and playback.....	29
<b>10</b>	<b>Technical specifications</b> .....	<b>30</b>
<b>11</b>	<b>Cleaning</b> .....	<b>31</b>
<b>12</b>	<b>Protecting the environment</b> .....	<b>32</b>
<b>13</b>	<b>Appendix</b> .....	<b>33</b>
	13.1 Kit list.....	33
	13.2 Song-style list.....	33
	13.3 Sound list.....	34
	13.4 MIDI implementation.....	40

# 1 General information

This user manual contains important information on the safe operation of the device. Read and follow all safety notes and all instructions. Save this manual for future reference. Make sure that it is available to all persons using this device. If you sell the device to another user, be sure that they also receive this manual.

Our products and user manuals are subject to a process of continuous development. We therefore reserve the right to make changes without notice. Please refer to the latest version of the user manual which is ready for download under [www.thomann.de](http://www.thomann.de).

## 1.1 Further information

On our website ([www.thomann.de](http://www.thomann.de)) you will find lots of further information and details on the following points:

Download	This manual is also available as PDF file for you to download.
Keyword search	Use the search function in the electronic version to find the topics of interest for you quickly.
Online guides	Our online guides provide detailed information on technical basics and terms.
Personal consultation	For personal consultation please contact our technical hotline.
Service	If you have any problems with the device the customer service will gladly assist you.

## 1.2 Notational conventions

This manual uses the following notational conventions:

### Letterings

The letterings for connectors and controls are marked by square brackets and italics.

**Examples:** *[VOLUME]* control, *[Mono]* button.

### Displays

Texts and values displayed on the device are marked by quotation marks and italics.

**Examples:** '24ch', 'OFF'.

**Instructions**

The individual steps of an instruction are numbered consecutively. The result of a step is indented and highlighted by an arrow.

**Example:**

1. ➤ Switch on the device.
2. ➤ Press [Auto].  
⇒ Automatic operation is started.
3. ➤ Switch off the device.

**Cross-references**

References to other locations in this manual are identified by an arrow and the specified page number. In the electronic version of the manual, you can click the cross-reference to jump to the specified location.

Example: See ➤ 'Cross-references' on page 5.

**1.3 Symbols and signal words**

In this section you will find an overview of the meaning of symbols and signal words that are used in this manual.

Signal word	Meaning
<b>DANGER!</b>	This combination of symbol and signal word indicates an immediate dangerous situation that will result in death or serious injury if it is not avoided.
<b>CAUTION!</b>	This combination of symbol and signal word indicates a possible dangerous situation that can result in minor injury if it is not avoided.
<b>NOTICE!</b>	This combination of symbol and signal word indicates a possible dangerous situation that can result in material and environmental damage if it is not avoided.
Warning signs	Type of danger
	Warning – danger zone.

## 2 Safety instructions

### Bestimmungsgemäßer Gebrauch

E-drum sets consist of a drum module and drum pads. The drum module converts the digital trigger signals from the drum pads into various drum sounds. Use the unit only as described in this manual. Any other use or use under other operating conditions is considered to be improper and may result in personal injury or property damage. No liability will be assumed for damages resulting from improper use.

This device may be used only by persons with sufficient physical, sensorial, and intellectual abilities and having corresponding knowledge and experience. Other persons may use this device only if they are supervised or instructed by a person who is responsible for their safety.

### Safety



#### **DANGER!**

##### **Danger for children**

Ensure that plastic bags, packaging, etc. are disposed of properly and are not within reach of babies and young children. Choking hazard!

Ensure that children do not detach any small parts (e.g. knobs or the like) from the unit. They could swallow the pieces and choke!

Never let children unattended use electrical devices.



#### **CAUTION!**

##### **Possible hearing damage**

With loudspeakers or headphones connected, the device can produce volume levels that may cause temporary or permanent hearing impairment.

Do not operate the device permanently at a high volume level. Decrease the volume level immediately if you experience ringing in your ears or hearing impairment.



#### **NOTICE!**

##### **Operating conditions**

This device has been designed for indoor use only. To prevent damage, never expose the device to any liquid or moisture. Avoid direct sunlight, heavy dirt, and strong vibrations.

Only operate the device within the ambient conditions specified in the chapter 'Technical specifications' of this user manual. Avoid heavy temperature fluctuations and do not switch the device on immediately after it was exposed to temperature fluctuations (for example after transport at low outside temperatures).

Dust and dirt inside can damage the unit. When operated in harmful ambient conditions (dust, smoke, nicotine, fog, etc.), the unit should be maintained by qualified service personnel at regular intervals to prevent overheating and other malfunction.



**NOTICE!**

**External power supply**

The device is powered by an external power supply. Before connecting the external power supply, ensure that the input voltage (AC outlet) matches the voltage rating of the device and that the AC outlet is protected by a residual current circuit breaker. Failure to do so could result in damage to the device and possibly the user.

Unplug the external power supply before electrical storms occur and when the device is unused for long periods of time to reduce the risk of electric shock or fire.



**NOTICE!**

**Possible staining**

The plasticiser contained in the rubber feet of this product may possibly react with the coating of your parquet, linoleum, laminate or PVC floor and after some time cause permanent dark stains.

In case of doubt, do not put the rubber feet directly on the floor, but use felt-pad floor protectors or a carpet.

### 3 Features

Special features of the device:

- 355 sounds
- 24 preset drum kits, 16 user kits
- 30 songs
- 4 × 8" snare and tom pads, 3 × 10" crash, ride and hi-hat cymbal pads
- 2 × pedals for bass drum and hi-hat
- Metronome
- Record and playback function
- Flexible assignment of pad sounds
- Headphones, AUX IN and USB-MIDI interface
- defeatable standby function



## 4 Scope of delivery



*Before you assemble your drum set, make sure the contents of package is complete according to the following list.*

- Frame with 3 × stand tube
- 3 × cymbal holder
- 3 × tom drum
- 3 × cymbal (ride, crash and hi-hat)
- Snare drum
- Sound module
- Hi-hat controller pedal
- Bass drum pedal
- 1 × set of drumsticks
- Labelled wiring harness
- Velcro fastener

## 5 Assembly

Loosen the screws of the clamps before sticking the tubes together. Mount the various elements in the specified sequence as shown in the illustration below.

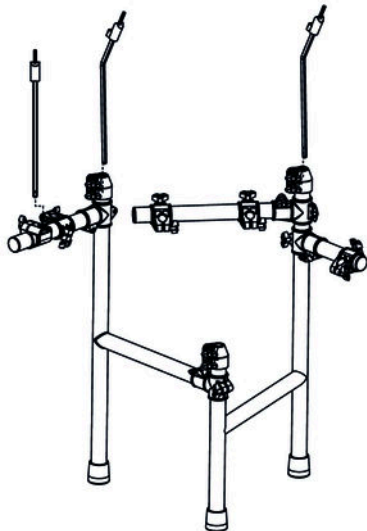

1. ▶ Attach the cymbal holders to the frame as shown.



2. ▶ Attach the cymbal to the holders as shown.

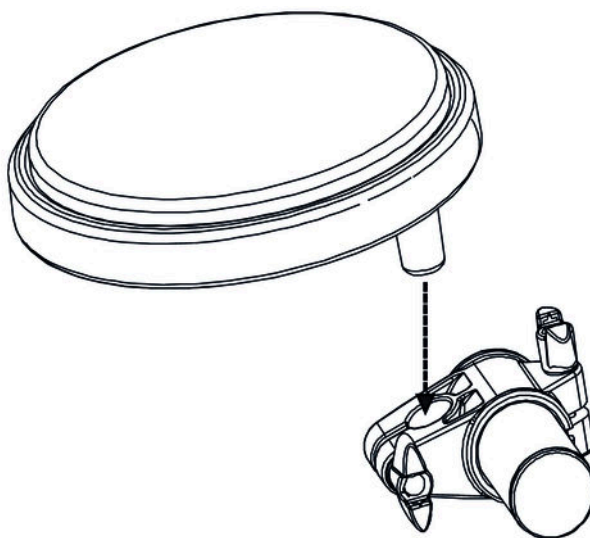

- 3.** ▶ Insert the rods of the snare drum pad and the three tom drum pads as shown into the holders on the stand tubes and tighten the wing nuts.

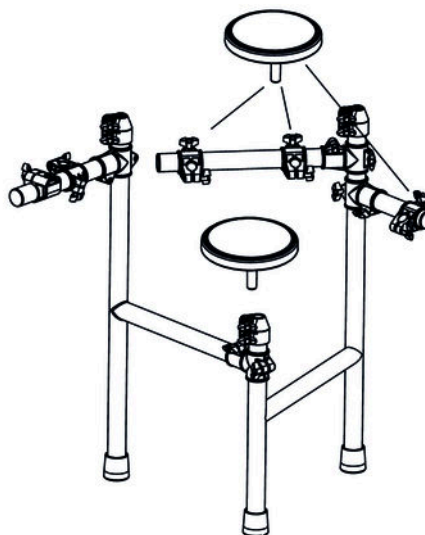

- 4.** ▶ Attach the pads to the frame on the locations shown in the illustration.



- 5.** ▶ Insert the rod of the sound module holder into the clamp on the frame and tighten the wing nut.

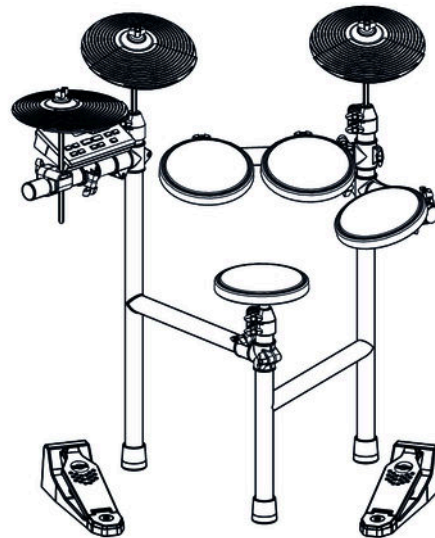

- 6.** ▶ Place the hi-hat controller pedal on the left side and the bass drum pedal on the right side.
- 7.** ▶ Connect the wiring harness to the interface on the rear panel of the sound module. Now connect the marked cables to the corresponding pads, cymbals and pedals.

The assembled e-drum set should now look like the following illustration:

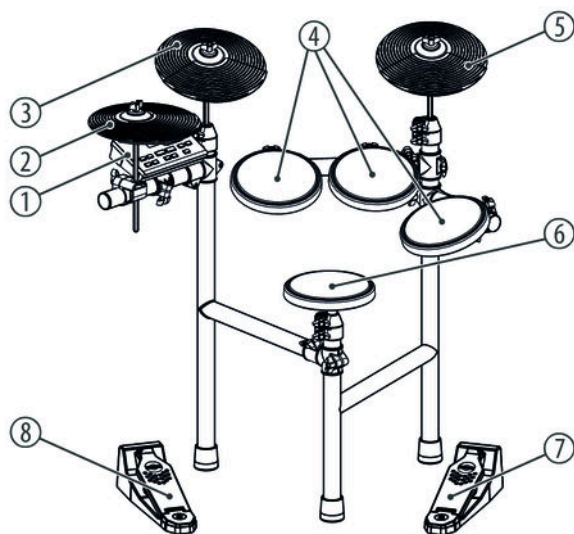

1	Sound module
2	Hi-hat cymbal
3	Crash Cymbal
4	Tom drums
5	Ride Cymbal
6	Snare drum
7	Bass drum pedal
8	Hi-hat controller pedal

## 6 Drum seat assembly (option)

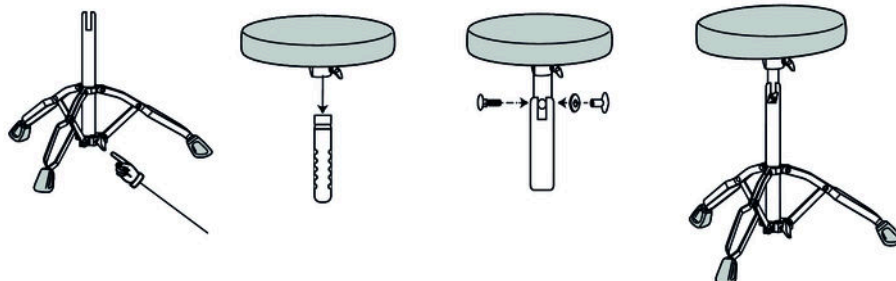

1. ➤ Pull out the legs of the seat and secure them with the wing nut.
2. ➤ Attach the drum seat to the height-adjustable pole and secure the seat with the wing nut.
3. ➤ Adjust the seat to the desired height as shown.

## 7 Installation

### Set-up and cabling

Set up the pads and cymbals according to your needs. Connect the drum module and wire all triggers to the drum module. Please observe the labelling on the rear of the drum module and the labelling on the individual cable ends. Finally check that all cables between the pads and the drum module have been properly connected.

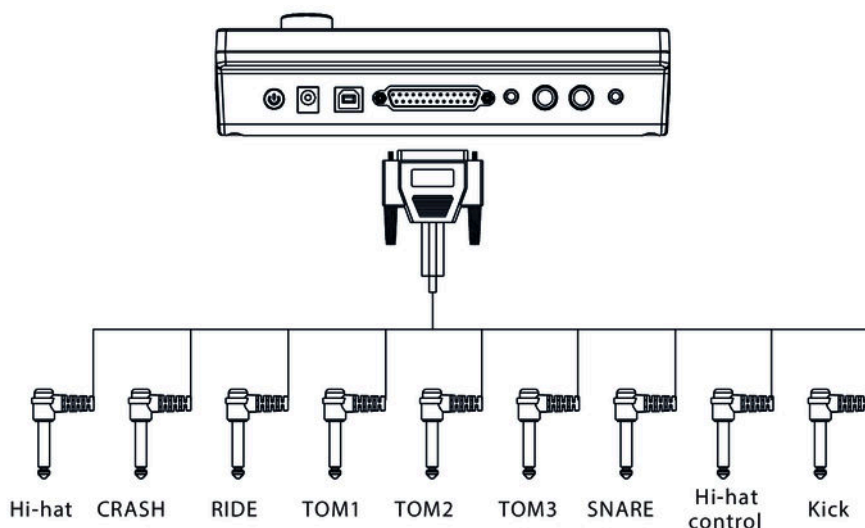

### Hi-hat controller

- You produce a closed hi-hat sound when you pedal the hi-hat controller while hitting the hi-hat
- You produce an open hi-hat sound when you do not pedal the hi-hat controller while hitting the hi-hat
- You produce the hi-hat pedal sound when pedalling the hi-hat controller directly without hitting the hi-hat
- An open hi-hat sound changes smoothly to a closed hi-hat sound when you pedal the hi-hat controller while hitting the hi-hat.

### Connecting the power adapter

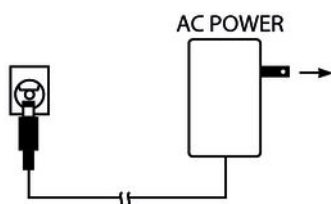

Connect the included power supply unit to the DC 9V input on the rear of the bottom case and then insert the power plug into the socket outlet.

## Connecting USB devices



Connect your computer to the USB port on the rear panel of the drum module.

## Connecting audio devices

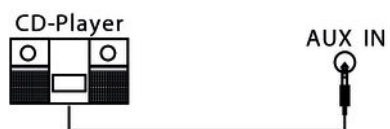

Connect audio devices like CD or MP3 player etc. to the AUX IN input socket on the rear panel of the drum module.

## Connecting headphones

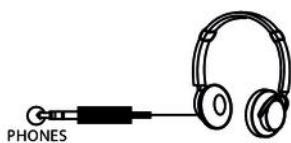

Connect your stereo headphones to the PHONES output on the rear panel of the drum module.



## 8 Connections and controls

### Drum module top view

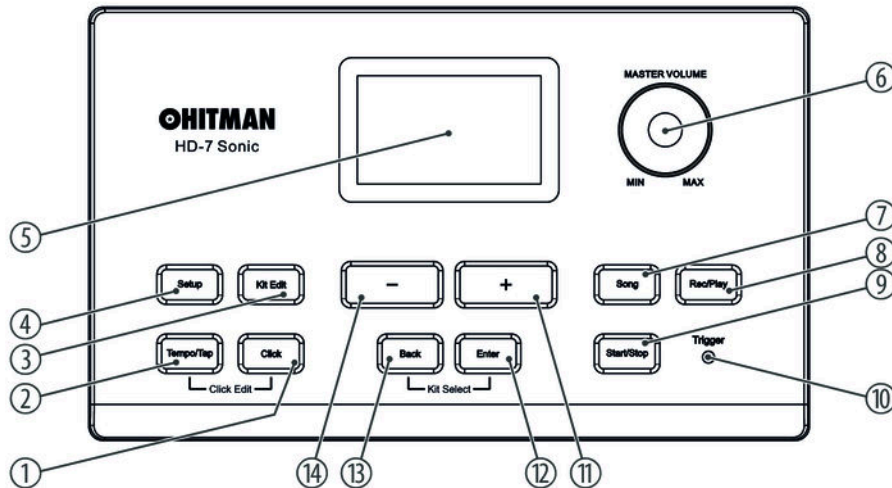

1	<p><i>[Click]</i></p> <p>Turns the metronome on and off.</p> <p>Simultaneously pressing <i>[Click]</i> and <i>[Tempo/Tap]</i>: Opens the metronome configuration.</p>
2	<p><i>[Tempo/Tap]</i></p> <p>Adjusts the tempo of the metronome and song playback.</p> <p>Simultaneously pressing <i>[Click]</i> and <i>[Tempo/Tap]</i>: Opens the metronome configuration.</p>
3	<p><i>[Kit Edit]</i></p> <p>Opens the drum kit selection.</p> <p>Calls up the setting mode. In this mode, various device parameters can be adjusted and the standby function can be switched off and on.</p>
4	<p><i>[Setup]</i></p> <p>Sets various parameters, e.g. for threshold, velocity curve, effect, etc.</p>
5	LED display
6	<p><i>[MASTER VOLUME]</i></p> <p>Adjusts the volume of the e-drum module.</p>
7	<p><i>[Song]</i></p> <p>Opens the song selection menu.</p>
8	<p><i>[Rec/Play]</i></p> <p>Opens the menu for song record and playback.</p>

9	<i>[Start / Stop]</i> Starts and stops song playback or recording.
10	LED <i>[Trigger]</i> Lights up when trigger pulses are generated.
11	<i>[+]</i> Scrolls forward through drum kits, parameters, sounds, etc.
12	<i>[Enter]</i> Confirms a selected value or parameter. Activates the next submenu level. By simultaneously pressing <i>[Back]</i> : Back to drum kit selection menu.
13	<i>[Back]</i> Returns to the parent menu level without changing the displayed value. By simultaneously pressing <i>[Enter]</i> : Back to kit selection menu.
14	<i>[-]</i> Scrolls backwards through a displayed selection.

### Display

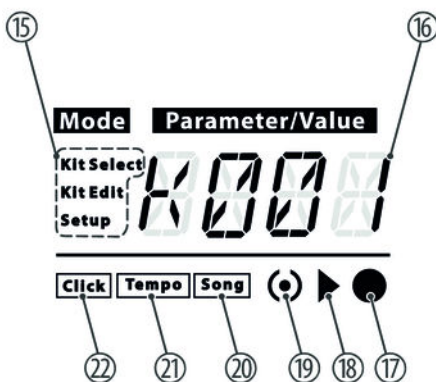

15	Shows the selected mode (kit select, kit edit, setup).
16	Shows the current selection (song, drum kit, parameter or value).
17	Shows that the recording function is active.
18	Shows that the playback function is active.
19	Flashes to the beat when the metronome is active, during recording or during playback.
20	Shows that song mode is active.
21	Without function
22	Shows that the metronome is active.

## Rear of the drum module

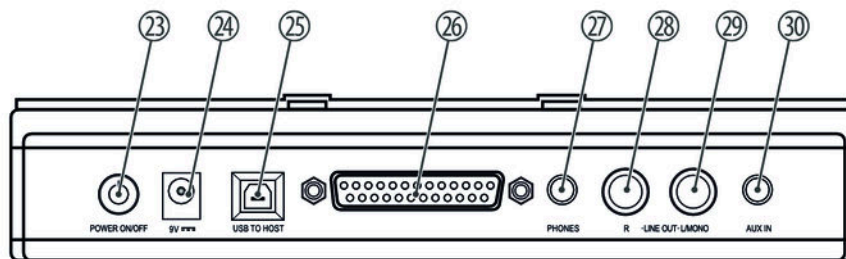

23	<i>[POWER ON/OFF]</i> Main switch. Turns the device on and off.
24	Connection socket for the 9 V power supply unit
25	<i>[USB TO HOST]</i> USB port for connecting a computer with USB-MIDI interface.
26	Serial interface for connecting the pads and cymbals
27	<i>[PHONES]</i> Headphones (3.5-mm stereo mini jack)
28, 29	<i>[LINE OUT L/R]</i> Connecting option for powered speakers or amplifiers.
30	<i>[AUX IN]</i> Input jack (3.5-mm stereo mini jack) for connecting audio devices, such as CD, MP3 players, etc.

## 9 Operating

### 9.1 Functions

#### Switching on



*Check all cable connections for correct fit before turning on  
Before switching on, turn the volume control [MASTER VOLUME] on the drum module to minimum.*

- ➔ Turn the drum module on using the main switch [POWER ON/OFF] on the rear panel.
  - ⇒ The display shows 'K001'. You can now select a drum kit.

#### Adjusting the volume

1. ➔ Turn the control [MASTER VOLUME] to [MIN].
2. ➔ Press [Start / Stop].
3. ➔ Turn the control [MASTER VOLUME] clockwise until you hear the playing song at a comfortable volume.
  - ⇒ The drum module volume is set.
4. ➔ Press [Start / Stop] to stop song playback.

#### Resetting the drum module to factory defaults

1. ➔ Turn the device off using the main switch [POWER ON/OFF].
2. ➔ Simultaneously press [+] and [-] while turning the device back on again using the main switch [POWER ON/OFF].
  - ⇒ The display shows 'RSET'. All parameters of the drum module are reset to factory settings.

### 9.2 Drum kits

#### Selecting a drum kit

A drum kit is a compilation in which a certain sound and several sound parameters are assigned to each trigger. Selecting different drum kits lets you customise the sound of your e-drum sets in seconds to the desired music genre.

1. ➔ Simultaneously press [Back] and [Enter] to call up the menu item 'Kit Select'. The display shows the number of the first preset drum kit.
2. ➔ Use [+] or [-] to select the desired kit.

## Selecting an instrument

1. ➤ Press *[Kit Edit]* to call up the menu for editing the drum kits. The display shows 'INST'.
2. ➤ Confirm the selection with *[Enter]*.
3. ➤ Press *[+]* or *[-]* repeatedly until the display shows the desired instrument. The following instruments are available:

Display	Instrument
KICK	Bass Drum
SNAR	Snare
TOM1	Tom 1
TOM2	Tom 2
TOM3	Tom 3
HH-0	Open hi-hat
HH-C	Closed hi-hat
HH-P	Hi-hat pedal
HH-S	Hi-hat splash
CRSH	Crash
RIDE	Ride

4. ➤ Use *[Enter]*, use *[+]* / *[-]* or a strong hit on the respective pad to select the desired instrument and confirm with *[Enter]*. You can now listen to the selection with 'Start/Stop'.
5. ➤ Press again *[Enter]* to save the selection. Use *[Back]* to return to the previous menu level without saving the settings.
6. ➤ Simultaneously press *[+]* and *[-]* to restore the factory settings.

## Setting the pad volume

1. ➤ Press *[Kit Edit]* to call up the menu for editing the drum kits. The display shows 'INST'.
2. ➤ Press *[+]* or *[-]* repeatedly until the display shows 'LEVL'.
3. ➤ Use *[Enter]*, use *[+]* or *[-]* or a strong hit on the respective pad to select the desired instrument and confirm with *[Enter]*.
4. ➤ Press *[+]* or *[-]* repeatedly until the display shows the desired volume value (display shows '000' ... '127'). You can now listen to the selection with 'Start/Stop'.
5. ➤ Press again *[Enter]* to save the selection. With *[Back]* to return to the previous menu level without saving the settings.

## Setting the reverb

1. ➤ Press *[Kit Edit]* to call up the menu for editing the drum kits. The display shows 'INST'.
2. ➤ Press *[+]* or *[-]* repeatedly until the display shows 'RSND' and confirm with *[Enter]*.
3. ➤ Press *[+]* or *[-]* repeatedly until the display shows the desired value for the reverb effect (display shows '000' ... '127').
4. ➤ Press again *[Enter]* to save the selection. With *[Back]* to return to the previous menu level without saving the settings.

## Setting the chorus

1. ➤ Press *[Kit Edit]* to call up the menu for editing the drum kits. The display shows 'INST'.
2. ➤ Press *[+]* or *[-]* repeatedly until the display shows 'CSND' and confirm with *[Enter]*.
3. ➤ Press *[+]* or *[-]* repeatedly until the display shows the desired value for the chorus effect (display shows '000' ... '127').
4. ➤ Press again *[Enter]* to save the selection. With *[Back]* to return to the previous menu level without saving the settings.

## Setting the reverb type

1. ➤ Press *[Kit Edit]* to call up the menu for editing the drum kits. The display shows 'INST'.
2. ➤ Press *[+]* or *[-]* repeatedly until the display shows 'RTYP' and confirm with *[Enter]*.
3. ➤ Press *[+]* or *[-]* repeatedly until the display shows the desired reverb type. The following reverb types are available:

Display	Reverb type
ROM1 ... 3	Room
HAL1 ... 2	Reverb
PLAT	Plate
DELY	Delay
ECHO	Echo

4. ➤ Press again *[Enter]* to save the selection. With *[Back]* to return to the previous menu level without saving the settings.

## Setting the chorus type

1. ➤ Press *[Kit Edit]* to call up the menu for editing the drum kits. The display shows 'INST'.
2. ➤ Press *[+]* or *[-]* repeatedly until the display shows 'CTYP' and confirm with *[Enter]*.

3. ➤ Press [ + ] or [ - ] repeatedly until the display shows the desired chorus type (display shows 'CHR1 ... 4', 'FBAK', 'FLG1', 'SDLY', 'DLFY', 'FLG2', 'FLG3', 'CLS1 ... 3'.
4. ➤ Press again [Enter] to save the selection. With [Back] to return to the previous menu level without saving the settings.

### Copying drum kits

You can copy drum kits from any of the 24 memory locations, to e.g. change the order of the drum kits.

1. ➤ Press [Kit Edit] to call up the menu for editing the drum kits. The display shows 'INST'.
2. ➤ Press [ + ] or [ - ] repeatedly until the display shows 'COPY' and confirm with [Enter].
3. ➤ Press [ + ] or [ - ] repeatedly until the display shows the number of the drum kit you want to target.
4. ➤ Press again [Enter] to save the previously set drum kit to the number of the selected drum kit.
  - ⇒ The display shows 'DONE'. The drum kit previously stored on this number will be overwritten with the selected drum kit.
5. ➤ Press [Back] to return to the previous menu level without saving the settings.

### Resetting the drum kit effects to factory defaults

You can separately reset the drum kit's instruments and effects to factory settings.

To reset the instruments to factory settings:

1. ➤ Press [Kit Edit] to call up the menu for editing the drum kits. The display shows 'INST'.
2. ➤ Press [ + ] or [ - ] repeatedly until the display shows 'RSET' and confirm with [Enter].
3. ➤ Press [ + ] or [ - ] repeatedly until the display shows 'DRMS'.
4. ➤ Press again [Enter].
  - ⇒ The display shows 'DONE'. The drum kit's instruments are reset to factory settings.

To reset the effects to factory settings:

1. ➤ Press [Kit Edit] to call up the menu for editing the drum kits. The display shows 'INST'.
2. ➤ Press [ + ] or [ - ] repeatedly until the display shows 'RSET' and confirm with [Enter].
3. ➤ Press [ + ] or [ - ] repeatedly until the display shows 'EFCT'.
4. ➤ Press again [Enter].
  - ⇒ The display shows 'DONE'. The drum kit's effects are reset to factory settings.

## 9.3 Setup

### Configuring the triggers

The trigger function lets you set how the e-drum set responds to your playing style. You can set the parameters for sensitivity, threshold, velocity curve, and crosstalk.

1. ➤ Press *[Setup]* to call up the menu for editing the settings. The display shows 'TRIG'.
2. ➤ Confirm the selection with *[Enter]*.
3. ➤ Press *[+]* or *[-]* repeatedly until the display shows the desired instrument.
4. ➤ Press *[Enter]* and press *[+]* or *[-]* repeatedly until the display shows the desired parameter you want to change. The following parameters are available:

Display	Function	
'SENS'	Sets the sensitivity of the selected instrument (display shows '001' ... '005').	
'THRS'	Sets the threshold that must be exceeded for a pad to respond. This is to prevent a pad from responding to the vibrations of other pads (display shows '000' ... '050').	
'CURV'	Sets the velocity values for the selected instrument to define the type of response. There are four velocity curves to choose from.	
	'EASY'	Easily play the maximum MIDI Velocity 127
	'NORL'	Even transitions with velocity changes
	'DYN'	High adaptability to loud or quiet play
'FID'	MIDI Velocity 100, regardless of the strength of the hit	
'XTLK'	Sets the crosstalk value to avoid overlays caused by unintentionally addressed pads. If a pad unintentionally responds to the hit on another pad, this can be prevented by raising the crosstalk value for the respective pad (display shows '000' ... '080').	
'COPY'	Copies the settings of an instrument and transfers them to another instrument.	

5. ➤ Press *[Enter]* and press *[+]* or *[-]* repeatedly until the display shows the desired new value.
6. ➤ Press again *[Enter]* to save the selection. With *[Back]* to return to the previous menu level without saving the settings.

### Selecting Midi channels

1. ➤ Press *[Setup]* to call up the menu for editing the settings. The display shows 'TRIG'.
2. ➤ Press again *[Setup]*, *[+]* or *[-]* repeatedly until the display shows 'CHAN'.



3. ➤ Press *[Enter]* and use *[+]* or *[-]* to select the desired MIDI channel (display shows '0001' ... '016', 'OFF').
4. ➤ Press again *[Enter]* to save the selection. With *[Back]* to return to the previous menu level without saving the settings.

### Using a drum pad as MIDI trigger (Local Off)

By hitting a pad, external audio sources can be triggered via USB without the pad itself being heard. This feature is called Local Off.

1. ➤ Press *[Setup]* to call up the menu for editing the settings. The display shows 'TRIG'.
2. ➤ Press again *[Setup]*, *[+]* or *[-]* repeatedly until the display shows 'LOCL'.
3. ➤ Press *[Enter]* and use *[+]* or *[-]* to select either 'Off' or 'On'. The default setting is 'On'. In the 'Off' setting, the pads are not addressed directly.
4. ➤ Press *[Enter]* and use *[+]* or *[-]* to select either 'Off' or 'On'. The default setting is 'On'.
5. ➤ Press again *[Enter]* to save the selection. With *[Back]* to return to the previous menu level without saving the settings.

### Turning off all drum kit effects

Many drum kits include effects like reverb and chorus by default. They can be turned off if e.g. external effects are to be fed in.

1. ➤ Press *[Setup]* to call up the menu for editing the settings. The display shows 'TRIG'.
2. ➤ Press again *[Setup]*, *[+]* or *[-]* repeatedly until the display shows 'EFACT'.
3. ➤ Press *[Enter]* and use *[+]* or *[-]* to select either 'REVB' to turn the reverb effect on or off, or 'CHRS' to turn the chorus effect on or off.
4. ➤ Press again *[Enter]* to save the selection. With *[Back]* to return to the previous menu level without saving the settings.

### Resetting triggers to factory defaults

1. ➤ Press *[Setup]* to call up the menu for editing the settings. The display shows 'TRIG'.
2. ➤ Press again *[Setup]*, *[+]* or *[-]* repeatedly until the display shows 'RSET'.
3. ➤ Press again *[Setup]*, *[+]* or *[-]* repeatedly until the display shows 'TRGS'.
4. ➤ Press *[Enter]*.  
⇒ The display shows 'DONE'. The values for the parameter sensitivity 'SENS', threshold 'THRS', velocity curve 'CURV' and crosstalk 'XTLK' are reset to factory defaults.

### Resetting drum kits to factory defaults

1. ➤ Press *[Setup]* to call up the menu for editing the settings. The display shows 'TRIG'.
2. ➤ Press again *[Setup]*, *[+]* or *[-]* repeatedly until the display shows 'RSET'.

3. ➤ Press *[Enter]* and press *[+]* or *[-]* repeatedly until the display shows 'KITS'.
4. ➤ Press *[Enter]*.
  - ⇒ The display shows 'DONE'. The values for all drum kits except the trigger settings 'TRGS' are reset to factory defaults.

## Enabling sleep mode

1. ➤ Press *[Setup]* to call up the menu for editing the settings. The display shows 'TRIG'.
2. ➤ Press again *[Setup]*, *[+]* or *[-]* repeatedly until the display shows 'POWR'.
3. ➤ Press *[Enter]*, use *[+]* or *[-]* to select either 'On' or 'Off' and confirm the selection with *[Enter]*.

Display	Function
'On'	Sleep mode is activated. After 30 minutes inactivity, the unit will automatically switch off.  To start from sleep mode, press <i>[POWER ON/OFF]</i> twice.
'Off'	Sleep mode is not activated.

## 9.4 Songs

1. ➤ Press *[Song]* to call up the song list. The display shows the number of the last selected song.
2. ➤ Use *[+]* or *[-]* to select the desired song.
3. ➤ Press *[Start / Stop]* to start or stop song playback.

## Muting the drum track

The drum track in the preinstalled songs can be muted to, e.g., let you play the drums along with it yourself.

1. ➤ Press *[Song]* to call up the song list. The display shows 'S001'.
2. ➤ Press *[Enter]* and press *[+]* or *[-]* repeatedly until the display shows 'DRUM'.
3. ➤ Press *[Enter]*, use *[+]* or *[-]* to select 'Off' to mute the drum track. Confirm the selection with *[Enter]*.

When power is turned off, the setting is automatically reset to 'On'.

## Setting the drum track volume

The volume of the drum track in the preinstalled songs can be set separately.

1. ▶ Press *[Song]* to call up the song list. The display shows 'S001'.
2. ▶ Press *[Enter]* and press *[+]* or *[-]* repeatedly until the display shows 'DVOL'.
3. ▶ Press *[Enter]* and use *[+]* or *[-]* to adapt the drum track volume. Simultaneously press *[+]* and *[-]* to reset the volume of the drum track to factory settings (value 028). Confirm the selection with *[Enter]*.

When power is turned off, the drum track volume is automatically reset to factory setting.

### Setting the accompaniment instruments volume

The volume of the accompaniment instruments in the preinstalled songs can be set separately.

1. ▶ Press *[Song]* to call up the song list. The display shows 'S001'.
2. ▶ Press *[Enter]* and press *[+]* or *[-]* repeatedly until the display shows 'ACCV'.
3. ▶ Press *[Enter]* and use *[+]* or *[-]* to adapt the volume of the accompaniment instruments. Simultaneously press *[+]* and *[-]* to reset the volume of the accompaniment instruments to factory settings (value 028). Confirm the selection with *[Enter]*.

When power is turned off, the accompaniment instruments volume is automatically reset to factory setting.

### Resetting drum track and accompanying instruments to factory defaults

1. ▶ Press *[Song]* to call up the song list. The display shows 'S001'.
2. ▶ Press *[Enter]* and press *[+]* or *[-]* repeatedly until the display shows 'RSET'.
3. ▶ Press *[Enter]*.
  - ⇒ The display shows 'DONE'. The values for the drum track and the accompanying instruments are reset to factory settings.

## 9.5 Metronome

### Setting the metronome volume

1. ▶ Simultaneously press *[Tempo/Tap]* and *[Click]* to call up the menu for editing the metronome.
2. ▶ Press *[Enter]* and press *[+]* or *[-]* repeatedly until the display shows 'LEVL'.
3. ▶ Press *[Enter]* and use *[+]* or *[-]* to adapt the volume of the metronome. Simultaneously press *[+]* and *[-]* to reset the metronome volume to factory settings (value 020). Confirm the selection with *[Enter]*.

## Setting the metronome time signature

1. Simultaneously press *[Tempo/Tap]* and *[Click]* to call up the menu for editing the metronome.
2. Press *[Enter]* and press *[+]* or *[-]* repeatedly until the display shows 'TSIG'.
3. Press *[Enter]* and use *[+]* or *[-]* to select the desired time signature (display shows '1-4', '2-4', '3-4', '4-4', '5-4', '6-4', '7-4', '3-8'). Simultaneously press *[+]* and *[-]* to reset the time signature of the metronome to factory settings (value 4 4). Confirm the selection with *[Enter]*.

## Setting the metronome sound

1. Simultaneously press *[Tempo/Tap]* and *[Click]* to call up the menu for editing the metronome.
2. Press *[Enter]* and press *[+]* or *[-]* repeatedly until the display shows 'SND'.
3. Press *[Enter]* and use *[+]* or *[-]* to select one of the metronome sounds. Confirm the selection with *[Enter]*.

## Resetting the metronome to factory defaults

1. Simultaneously press *[Tempo/Tap]* and *[Click]* to call up the menu for editing the metronome.
2. Press *[+]* or *[-]* repeatedly until the display shows 'RSET'.
3. Press *[Enter]*.
  - ⇒ The display shows 'DONE'. The values for the metronome are reset to factory settings.

## 9.6 Tempo

### Changing the tempo

There are two ways you can change the tempo using *[TEMPO / TAP]*.

1. Press *[Tempo/Tap]*. The display shows the currently set tempo.
2. Press *[+]* or *[-]* repeatedly until the desired value is shown (display shows '020' to '240').

or:
3. Press *[Tempo/Tap]*. The display shows the currently set tempo.
4. Press *[Enter]*. The value of the currently set tempo is shown briefly in the display.
5. Rhythmically hit a pad four times to change the tempo. The new value is determined by the time interval between the four hits.
6. To reset the tempo to factory settings, simultaneously press *[+]* and *[-]*.

---

## 9.7 Record and playback

### Record

1. ▶ Press *[Rec/Play]* and press *[+]* or *[-]* until the display shows 'RECD'.
2. ▶ Press *[Start / Stop]* to start recording. Press *[Start / Stop]* again to stop recording.

### Playback

1. ▶ Press *[Rec/Play]* and press *[+]* or *[-]* until the display shows 'PLAY'.
2. ▶ Press *[Start / Stop]* to start playback. Press *[Start / Stop]* again to stop playback.

### Deleting a recording

1. ▶ Press *[Rec/Play]* and press *[+]* or *[-]* until the display shows 'CLER'.
2. ▶ Press *[Enter]*. The recording is deleted.

## 10 Technical specifications

Input connections	USB port	USB 2.0 type B
	Combined trigger connection	1 × sub D
	AUX in	1 × 3.5 mm phone socket
Output connections	Headphones	1 × 3.5 mm phone socket
	Main output left	1 × 1/4" phone socket
	Main output right	1 × 1/4" phone socket
Voices	355	
Effects	Reverb, Chorus	
Drum kits	24 preset kits, 16 user kits	
Demo and practice songs	30 preprogrammed songs	
Power supply	Plug-in power supply (9 V $\overline{\text{---}}$ / 600 mA, centre positive)	
Dimensions (W × H × D)	1020 mm × 560 mm × 1050 mm	
Weight	11.2 kg	
Ambient conditions	Temperature range	0 °C...40 °C
	Relative humidity	50 %, non-condensing

### Further information

Rack included	Yes
Seat included	No
Pedal included	No
Headphones included	No
Mesh Head Pads	Yes
Pads in Stereo	No
Number of direct outputs	0

## 11 Cleaning

### Components

Clean the externally accessible device parts regularly. The frequency of cleaning depends on the operating environment: wet, smoky or particularly dirty surroundings can cause more accumulation of dirt on the device parts.

- Clean with a soft dry cloth.
- Stubborn dirt can be removed with a slightly dampened cloth.
- Use only pH-neutral, solvent-free and non-abrasive cleaning agents. Never use cleaners containing alcohol or thinner.
- Do not place vinyl objects on the device, as vinyl may stick to the surface or cause it to discolour.

## 12 Protecting the environment

### Disposal of the packaging material



For the transport and protective packaging, environmentally friendly materials have been chosen that can be supplied to normal recycling.

Ensure that plastic bags, packaging, etc. are properly disposed of.

Do not just dispose of these materials with your normal household waste, but make sure that they are collected for recycling. Please follow the notes and markings on the packaging.

### Disposal of your old device



This product is subject to the European Waste Electrical and Electronic Equipment Directive (WEEE) in its currently valid version. Do not dispose with your normal household waste.

Dispose of this device through an approved waste disposal firm or through your local waste facility. When discarding the device, comply with the rules and regulations that apply in your country. If in doubt, consult your local waste disposal facility.



## 13 Appendix

### 13.1 Kit list

No.	Name	No.	Name
1	Acoustic 1	21	Rock 2
2	Acoustic 2	22	Reggae-pop
3	Room	23	Brush
4	Nine-oh	24	Modern R&B
5	Rock 1	25	User 1
6	Dance Club	26	User 2
7	Jazz	27	User 3
8	Rap-hop	28	User 4
9	Early R&B	29	User 5
10	Electronic 1	30	User 6
11	Crunch	31	User 7
12	Compressed	32	User 8
13	Electronic 2	33	User 9
14	Analog	34	User 10
15	Drum Box 1	35	User 11
16	Latin	36	User 12
17	Pop	37	User 13
18	Eight-oh	38	User 14
19	Electro-pop	39	User 15
20	Trash	40	User 16

### 13.2 Song-style list

No.	Name	No.	Name
01	Rock Shuffle	05	Hard Rock
02	Surf Pop	06	Pop Bossa
03	Techno	07	80's Rock
04	60's Rock	08	16 Beat

No.	Name	No.	Name
09	Pop Shuffle	20	Big Band
10	Guitar Pop	21	Country 8 Beat
11	Modern 6/8	22	3/4 Gospel
12	Swing Funk	23	Soul
13	Piano Ballad	24	8 Beat Two
14	Rap	25	Reggae
15	16 Beat Ballad	26	Swing Reggae
16	Pop Ballad	27	English Waltz
17	8 Beat Dance	28	Tango
18	8 Beat Modern	29	Rhythm & Blues
19	70's Disco	30	Polka

### 13.3 Sound list

Group 1: Kick Drums			
01	Acoustic kick 1	17	Rock kick 3
02	Acoustic kick_2	18	Rock kick 4
03	Room kick 1	19	Rock kick 5
04	Room kick 2	20	8-oh kick
05	Rock kick 1	21	9-oh kick
06	Jazz kick 1	22	Dance club kick
07	Early R&B kick	23	Rap-hop kick
08	Compressed kick	24	Electronic kick 1
09	Latin kick	25	Electronic kick 2
10	Pop kick	26	Analog kick
11	Trash_kick	27	Drum box kick 1
12	Rock kick 2	28	Drum box kick 2
13	Reggae-pop kick	29	Crunch kick
14	Brush kick	30	Electro-pop kick
15	Modern R&B kick	31	Thick kick
16	Big kick		

Group 2: Snare Drums			
01	Acoustic snare 1	32	Crunch snare 1
02	Piccolo snare 1	33	Electronic snare 2
03	Piccolo snare 2	34	Analog snare 2
04	Room snare 1	35	Crunch snare 2
05	Room snare 2	36	Drum box snare 3
06	Rock snare 1	37	Noise snare
07	Rock snare 2	38	Reso-snare
08	Rock snare 3	39	Bubble snare
09	Rock snare 4	40	Acoustic rimshot 1
10	Compressed snare	41	Early R&B rimshot
11	Jazz snare	42	Pop rimshot 1
12	Acoustic snare 2	43	Piccolo rimshot 1
13	Acoustic snare 3	44	Rock rimshot 1
14	Trash snare	45	Jazz rimshot 1
15	Pop snare 1	46	Acoustic rimshot 2
16	Reggae-pop snare	47	Compressed rimshot
17	Brush snare	48	Room rimshot
18	Early R&B snare	49	Pop rimshot 2
19	Pop snare 2	50	Rock rimshot 2
20	Latin snare + tambourine	51	Reggae-pop rimshot
21	Electro-pop snare	52	Brush rimshot
22	Rap-hop snare	53	Analog rimshot 1
23	Analog snare	54	Modern R&B rimshot
24	Modern R&B snare	55	Trash rimshot
25	Rock snare 5	56	Drum box rimshot 1
26	Electronic snare 1	57	8-oh rimshot
27	Drum box snare 1	58	Dance club rimshot
28	8-oh snare	59	Electronic rimshot 1
29	Dance club snare	60	Crunch rimshot
30	9-oh snare	61	Electronic rimshot 2
31	Drum box snare 2	62	Analog rimshot 2

63	Drum box rimshot 2	66	Piccolo rimshot 2
64	Electro-pop rimshot	67	Rock snare 6
65	Piccolo snare 3	68	Rock rimshot 3

Group 3: Toms			
01	Acoustic tom 1 (high)	29	D-dub tom (mid)
02	Acoustic tom 1 (mid)	30	D-dub tom (low)
03	Acoustic tom 1 (low)	31	Rock tom 3 (high)
04	Acoustic tom 2 (high)	32	Rock tom 3 (mid)
05	Acoustic tom 2 (mid)	33	Rock tom 3 (low)
06	Acoustic tom 2 (low)	34	Rock tom 4 (high)
07	Room tom 1 (high)	35	Rock tom 4 (mid)
08	Room tom 1 (mid)	36	Rock tom 4 (low)
09	Room tom 1 (low)	37	Rock tom 5
10	Compressed tom (high)	38	Modern R&B tom (high)
11	Compressed tom (mid)	39	Modern R&B tom (mid)
12	Compressed tom (low)	40	Modern R&B tom (low)
13	Rock tom 1 (high)	41	Jazz tom (high)
14	Rock tom 1 (mid)	42	Jazz tom (mid)
15	Rock tom 1 (low)	43	Jazz tom (low)
16	Rock tom 2 (high)	44	Brush tom (high)
17	Rock tom 2 (mid)	45	Brush tom (mid)
18	Rock tom 2 (low)	46	Brush tom (low)
19	Pop tom 1 (high)	47	Early R&B tom (high)
20	Pop tom 1 (mid)	48	Early R&B tom (mid)
21	Pop tom 1 (low)	49	Early R&B tom (low)
22	Pop tom 2 (high)	50	Reggae-pop tom & timbale
23	Pop tom 2 (mid)	51	Reggae-pop tom & conga
24	Pop tom 2 (low)	52	Reggae-pop tom & conga
25	Tight tom (high)	53	Latin tom & conga
26	Tight tom (mid)	54	Latin tom & bongo
27	Tight tom (low)	55	Electro-pop tom (high)
28	D-dub tom (high)	56	Electro-pop tom (mid)

57	Electro-pop tom (low)	77	Analog tom (mid)
58	Electro-pop tom 2 (high)	78	Analog tom (low)
59	Electro-pop tom 2 (mid)	79	9-oh tom (high)
60	Electro-pop tom 2 (low)	80	9-oh tom (mid)
61	Trash tom (high)	81	9-oh tom (low)
62	Trash tom (mid)	82	9-oh tom 2 (high)
63	Trash tom (low)	83	9-oh tom 2 (mid)
64	Crunch tom (high)	84	9-oh tom 2 (low)
65	Crunch tom (mid)	85	8-oh tom fall (high)
66	Crunch tom (low)	86	8-oh tom fall (mid)
67	Rap-hop tom (high)	87	8-oh tom fall (low)
68	Rap-hop tom (mid)	88	Drum box tom 1 (high)
69	Rap-hop tom (low)	89	Drum box tom 1 (mid)
70	Electronic tom 1 (high)	90	Drum box tom 1 (low)
71	Electronic tom 1 (mid)	91	Drum box tom 2 (high)
72	Electronic tom 1 (low)	92	Drum box tom 2 (mid)
73	Electronic tom 2 (high)	93	Drum box tom 2 (low)
74	Electronic tom 2 (mid)	94	Dance club tom (high)
75	Electronic tom 2 (low)	95	Dance club tom (mid)
76	Analog tom (high)	96	Dance club tom (low)

Group 4: Cymbals			
01	Crash cymbal 1	11	Crispy splash
02	Crash cymbal 2	12	Trash splash
03	Rap-hop crash	13	Small splash
04	Mid crash 1	14	Electro splash
05	Mid crash 2	15	Dark splash
06	Dark crash	16	Low crash 1
07	18" crash 1	17	Low crash 2
08	18" crash 2	18	Analog crash
09	Mid splash	19	Electro-pop crash
10	High splash	20	Dance club crash

21	Electro crash 1	35	Cymbal ride plus bell 1
22	Electro crash 2	36	Cymbal ride plus bell 2
23	Falling crash	37	Trash ride
24	Submarine crash	38	Electronic ride 1
25	Sizzle ride	39	Electro-pop ride
26	Sizzle ride plus bell	40	High ping ride
27	Cimbal ride bell 1	41	Drum box ride
28	Cimbal ride bell 2	42	9-oh ride crash
29	Low ride	43	Pie tin ride
30	Early R&B ride	44	Electronic ride 2
31	Ride crash	45	Crunch ride
32	Brush ride	46	Electronic crash-ride
33	Cimbal ride plus bell 3	47	Electronic ride 3
34	Latin ride & cowbell		

Group 5: Hi-hats			
01	Brush hat 1 closed	18	Rock hat 2 foot
02	Brush hat 1 foot	19	Rock hat 2 open
03	Brush hat 1 open	20	Rock hat 2 splash
04	Brush hat 1 splash	21	Small hat 1 closed
05	Brush hat 2 closed	22	Small hat 1 foot
06	Brush hat 2 foot	23	Small hat 1 open
07	Brush hat 2 open	24	Small hat 1 splash
08	Brush hat 2 splash	25	Small hat 2 closed
09	Room hat closed	26	Small hat 2 foot
10	Room hat foot	27	Small hat 2 open
11	Room hat open	28	Small hat 2 splash
12	Room hat splash	29	Snappy brush hat closed
13	Rock hat 1 closed	30	Snappy brush hat foot
14	Rock hat 1 foot	31	Snappy brush hat open
15	Rock hat 1 open	32	Snappy brush hat splash
16	Rock hat 1 splash	33	Trash hat closed
17	Rock hat 2 closed	34	Trash hat foot

35	Trash hat open	62	Electronic hat 2 closed
36	Trash hat splash	63	Electronic hat 2 foot
37	Early R&B hat closed	64	Electronic hat 2 open
38	Early R&B hat foot	65	Electronic hat 2 splash
39	Early R&B hat open	66	Analog hat closed
40	Early R&B hat splash	67	Analog hat foot
41	Boom snap hat closed	68	Analog hat open
42	Boom snap hat open	69	Drum box hat 1 closed
43	Boom snap hat splash	70	Drum box hat 1 foot
44	Rock hat 3 closed	71	Drum box hat 1 open
45	Rock hat 3 open	72	9-oh hat closed
46	8-oh hat closed	73	9-oh hat foot
47	8-oh hat foot	74	9-oh hat open
48	8-oh hat open	75	9-oh hat splash
49	Dance club hat closed	76	Electro-pop hat closed
50	Dance club hat foot	77	Electro-pop hat foot
51	Dance club hat open	78	Electro-pop hat open
52	Rap-hop hat closed	79	Electro-pop hat splash
53	Rap-hop hat foot	80	Modern R&B hat closed
54	Rap-hop hat open	81	Modern R&B hat foot
55	Rap-hop hat splash	82	Modern R&B hat open
56	Electronic hat 1 closed	83	Modern R&B hat splash
57	Electronic hat 1 foot	84	Drum box hat 2 closed
58	Electronic hat 1 open	85	Drum box hat 2 foot
59	Crunch hat closed	86	Drum box hat 2 open
60	Crunch hat foot	87	Shaker hat closed
61	Crunch hat open		

Group 6: Percussion			
01	Agogo (high)	05	Conga (low)
02	Agogo (low)	06	Hand claps
03	Agogo (high/low)	07	Timbale (high)
04	Conga (high)	08	Timbale (low)

09	Triangle mute	18	Tambourine (up/down)
10	Triangle open	19	Cowbell
11	Triangle (open/mute)	20	8-oh cowbell
12	Woodblock (high)	21	Side H
13	Woodblock (low)	22	Side L
14	Woodblock (high/low)	23	Wood Block H
15	Shaker	24	Wood Block L
16	Tambourine (down)	25	Agogo H
17	Tambourine (up)	26	Agogo L

### 13.4 MIDI implementation

Function		Sent	Received	Notes
Basic Channel	Default	1-16 CH	1-16 CH	
	Changed	1-16 CH	1-16 CH	
Mode	Default	Mode 3	Mode 3	
	Messages	No	No	
	Altered	*****	No	
Note Number		0 ... 127	0 ... 127	
	True voice	*****	0 ... 127	
Velocity	Note ON	Yes 9nH, v = 1...- 127	Yes 9nH, v = 1...- 127	
	Note OFF	Yes, 8nH, v = 0	Yes, 9nH, v = 0 or 8nh	
After Keys		No	No	
Pitch Bender		No	Yes	



Function		Sent	Received	Notes
Control Change	0.32	Yes	Yes	Bank Select
	1	No	Yes	Modulation
	5	No	Yes	Portamento Time
	6	Yes	Yes	Data Entry
	7	Yes	Yes	Volume
	10	No	Yes	Pan
	11	No	Yes	Expression
	64	No	Yes	Sustain
	65	No	Yes	Portamento
	66	No	Yes	Sostenuto
	67	No	Yes	Soft Pedal
	80, 81	Yes	Yes	DSP Type
	91, 93	Yes	Yes	DSP Depth
	100, 101	No	Yes	RPN LSB, MSB
121	No	= (*1)	Reset All Controllers	
Program Change	True	Yes 0 ... 127	Yes 0 ... 127	
System Exclusive		No	No	
System Common	Song Position	No	No	
	Song Select	No	No	
	Tune	No	No	
Aux Messages	Local ON/OFF	No	Yes	All Notes Off is sent as All Sounds Off (CC# 120)
	All Notes OFF	Yes	Yes	
	Active Sense	No	Yes	
	Reset	No	Yes	

Mode 1: OMNI ON, POLY. Mode 2: OMNI ON, MONO. Mode 3: OMNI OFF, POLY. Mode 4: OMNI OFF, MONO

\*1: Registered parameter number: #0: Pitch sensitivity, #1: Fine tuning, #2: Coarse tuning in half-tones





