



**the
t.mix**

USB Mix 4
mixer

Musikhaus Thomann
Thomann GmbH
Hans-Thomann-Straße 1
96138 Burgebrach
Germany
Telephone: +49 (0) 9546 9223-0
E-mail: info@thomann.de
Internet: www.thomann.de

10.10.2018, ID: 441270

Table of contents

1	General information	4
	1.1 Further information.....	5
	1.2 Notational conventions.....	6
	1.3 Symbols and signal words.....	6
2	Safety instructions	8
3	Features	12
4	Installation	13
5	Connections and controls	15
6	Technical specifications	22
7	Plug and connection assignment	24
8	Protecting the environment	27

1 General information

This manual contains important instructions for the safe operation of the unit. Read and follow the safety instructions and all other instructions. Keep the manual for future reference. Make sure that it is available to all those using the device. If you sell the unit please make sure that the buyer also receives this manual.

Our products are subject to a process of continuous development. Thus, they are subject to change.

1.1 Further information

On our website (www.thomann.de) you will find lots of further information and details on the following points:

Download	This manual is also available as PDF file for you to download.
Keyword search	Use the search function in the electronic version to find the topics of interest for you quickly.
Online guides	Our online guides provide detailed information on technical basics and terms.
Personal consultation	For personal consultation please contact our technical hotline.
Service	If you have any problems with the device the customer service will gladly assist you.

1.2 Notational conventions

This manual uses the following notational conventions:



Letterings

The letterings for connectors and controls are marked by square brackets and italics.

Examples: *[VOLUME]* control, *[Mono]* button.

1.3 Symbols and signal words

In this section you will find an overview of the meaning of symbols and signal words that are used in this manual.

Signal word	Meaning
DANGER!	This combination of symbol and signal word indicates an immediate dangerous situation that will result in death or serious injury if it is not avoided.
NOTICE!	This combination of symbol and signal word indicates a possible dangerous situation that can result in material and environmental damage if it is not avoided.
Warning signs	Type of danger
	Warning – high-voltage.
	Warning – danger zone.

2 Safety instructions

Intended use

This device is intended to be used for amplification, mixing and playback of signals from musical instruments and microphones. Use the device only as described in this user manual. Any other use or use under other operating conditions is considered to be improper and may result in personal injury or property damage. No liability will be assumed for damages resulting from improper use.

This device may be used only by persons with sufficient physical, sensorial, and intellectual abilities and having corresponding knowledge and experience. Other persons may use this device only if they are supervised or instructed by a person who is responsible for their safety.

Safety**DANGER!****Danger for children**

Ensure that plastic bags, packaging, etc. are disposed of properly and are not within reach of babies and young children. Choking hazard!

Ensure that children do not detach any small parts (e.g. knobs or the like) from the unit. They could swallow the pieces and choke!

Never let children unattended use electrical devices.

**DANGER!****Electric shock caused by high voltages inside**

Within the device there are areas where high voltages may be present. Never remove any covers.

There are no user-serviceable parts inside.

Do not use the device if covers, protectors or optical components are missing or damaged.



DANGER!

Electric shock caused by short-circuit

Always use proper ready-made insulated mains cabling (power cord) with a protective contact plug. Do not modify the mains cable or the plug. Failure to do so could result in electric shock/death or fire. If in doubt, seek advice from a registered electrician.



NOTICE!

Risk of fire

Do not block areas of ventilation. Do not install the device near any direct heat source. Keep the device away from naked flames.



NOTICE!

Operating conditions

This device has been designed for indoor use only. To prevent damage, never expose the device to any liquid or moisture. Avoid direct sunlight, heavy dirt, and strong vibrations.



NOTICE!

Power supply

Before connecting the device, ensure that the input voltage (AC outlet) matches the voltage rating of the device and that the AC outlet is protected by a residual current circuit breaker. Failure to do so could result in damage to the device and possibly injure the user.

Unplug the device before electrical storms occur and when it is unused for long periods of time to reduce the risk of electric shock or fire.

3 Features

- 4-channel DJ mixer with USB player
- 4 stereo inputs (3 × phono / line, 1 × line / mic)
- 1 × microphone input (XLR)
- 1 × headphones output (stereo, as 1/4" phone jack)
- 1 × master output (RCA sockets)
- 1 × output for recording device (RCA sockets)
- 1 × USB port for playback

4 Installation

Unpack and carefully check that there is no transportation damage before using the unit. Keep the equipment packaging. To fully protect the device against vibration, dust and moisture during transportation or storage use the original packaging or your own packaging material suitable for transport or storage, respectively.

Create all connections while the device is off. Use the shortest possible high-quality cables for all connections. Take care when running the cables to prevent tripping hazards.

Connection options

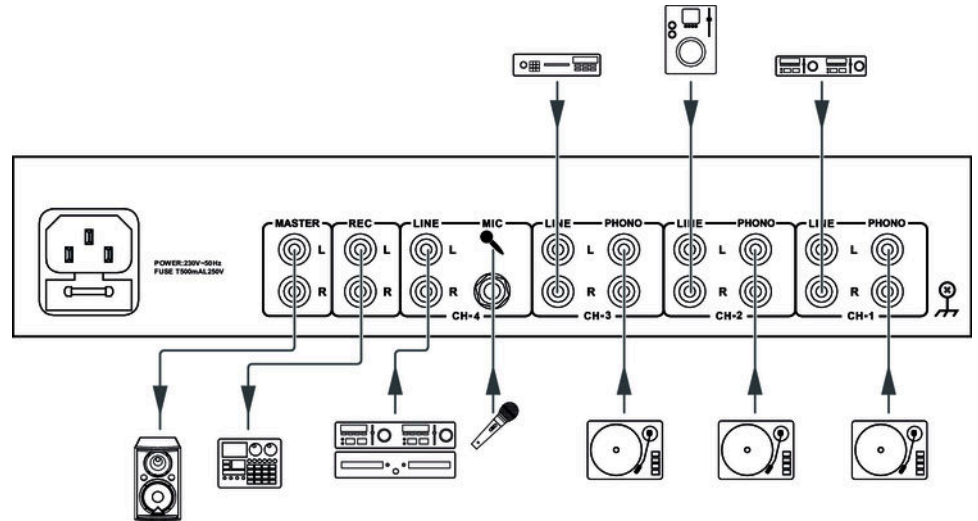

5 Connections and controls

Front panel

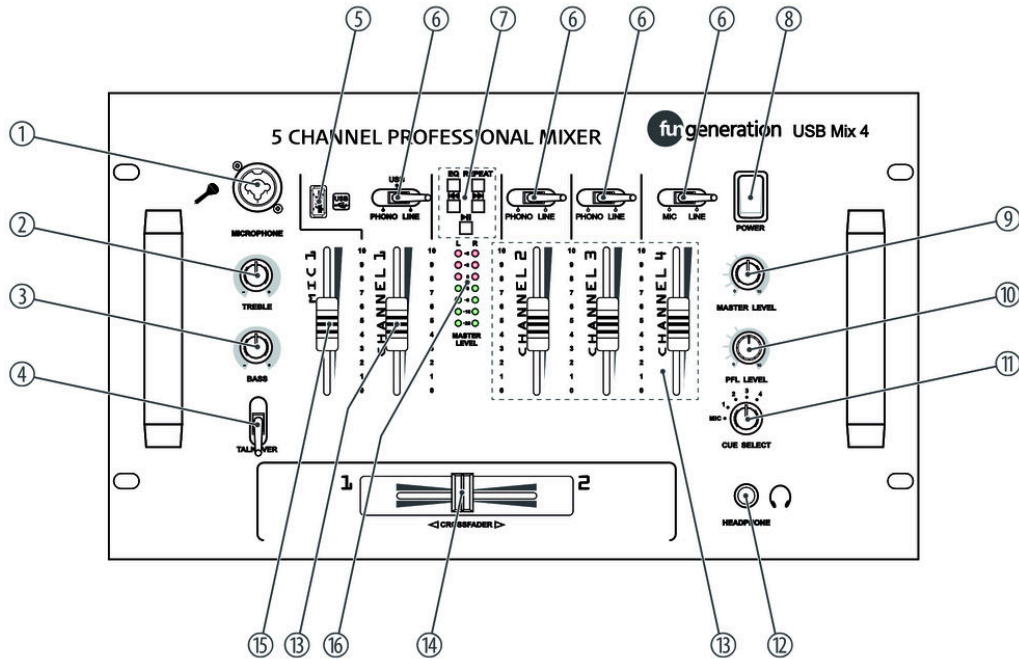

1	<i>[MIC 1]</i> Microphone input, designed as XLR / 1/4" phone combo socket
2	<i>[TREBLE]</i> Rotary treble control for the microphone input signal.
3	<i>[BASS]</i> Rotary bass control for the microphone input signal.
4	<i>[TALKOVER]</i> Enables the Talk over function. When the selector switch is moved in the ON position, all other signal sources are attenuated, so that the microphone is clearly audible. In OFF position, all signals retain their original level.
5	<i>[USB]</i> Connection for playback via a USB device. Before ejecting, pause USB stick playback or select another playback source.
6	<i>[PHONO / LINE]</i> Input source selector switch for the respective channel.

7	<p><i>[EQ]</i> EQ selection</p> <p><i>[REPEAT]</i> Plays a track repeatedly.</p> <p>⏮ Selects the previous track for playback.</p> <p>⏭ Selects the next track for playback.</p> <p>▶ Starts or pauses playback.</p>
8	<p><i>[POWER]</i> Main switch. Turns the device on and off.</p>
9	<p><i>[MASTER LEVEL]</i> Rotary control for adjusting the master out volume</p>

10	<i>[PFL LEVEL]</i> Rotary control for adjusting the headphones volume
11	<i>[CUE SELECT]</i> Rotary control to select the channel that can be heard through the headphones.
12	<i>[HEADPHONE]</i> Headphones output, designed as 1/4" phone socket (stereo).
13	CHANNEL 1...4 Sliders for adjusting the volume of the respective channel
14	<i>[CROSSFADER]</i> Slider for mixing the signals of the left and right channel If the controller is in middle position, both channels can be heard.
15	<i>[MIC 1]</i> Volume control for microphone 1.
16	<i>[MASTER LEVEL]</i> Level meter shows the volume of the output channel or the currently selected solo channel.

Rear panel

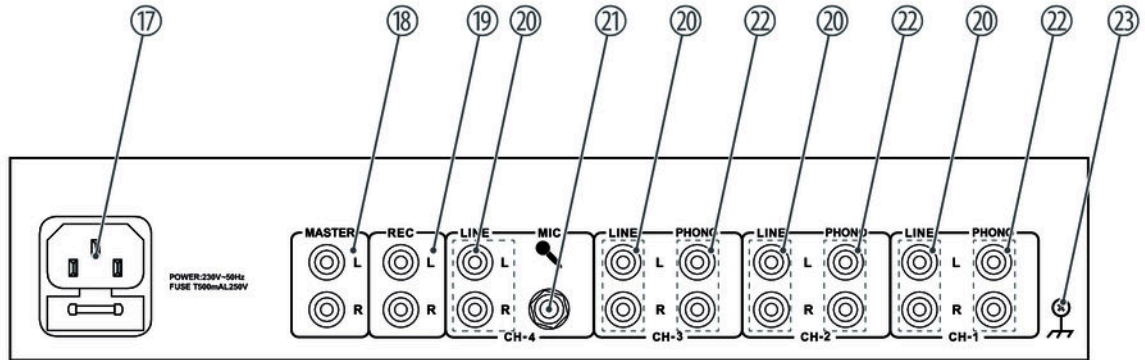

17	IEC chassis plug for operating voltage supply with fuse holder. Should the fuse have blown, disconnect the unit from the power supply and replace the fuse with a new fuse of the same type.
18	<i>[MASTER]</i> Master output for connecting an amplifier or powered speaker box, designed as RCA sockets.
19	<i>[REC]</i> Output for connecting a recording device.
20	<i>[LINE]</i> Inputs for line level signals (e.g., CD, DVD, MP3), designed as RCA sockets.
21	<i>[MIC]</i> Microphone input, designed as 1/4" phone jack.
22	<i>[PHONO]</i> Inputs for signals with phono level (e.g. turntables), designed as RCA sockets.
23	Grounding screw to reduce hum noise when connecting turntables

6 Technical specifications

Inputs	Microphone: 1.5 mV Phono: 3.2 mV Line: 150 mV
Outputs	Master: 1 V Rec: 1 V
Input impedance	Microphone: 2.2 k Ω Phono: 47 k Ω Line: 47 k Ω
Output impedance	Master: 600 Ω Rec: 600 Ω
Tone control (bass, treble)	+12 dB...-12 dB
Frequency range	20 Hz...20 kHz, ± 2 dB

Signal-to-noise ratio	> 70 dB
THD	0.02 %
Operating supply voltage	230 V ~ 50 Hz
Fuse	5 mm × 20 mm, 500 mA, 250 V, slow-blow
Dimensions (W × H × D)	382 mm × 220 mm × 130 mm
Weight	2.6 kg

7 Plug and connection assignment

Introduction

This chapter will help you select the right cables and plugs to connect your valuable equipment in such a way that a perfect sound experience is ensured.

Please note these advices, because especially in 'Sound & Light' caution is indicated: Even if a plug fits into the socket, an incorrect connection may result in a destroyed power amp, a short circuit or 'just' in poor transmission quality!

Balanced and unbalanced transmission

Unbalanced transmission is mainly used in semi-professional environment and in hifi use. Instrument cables with two conductors (one core plus shielding) are typical representatives of the unbalanced transmission. One conductor is ground and shielding while the signal is transmitted through the core.

Unbalanced transmission is susceptible to electromagnetic interference, especially at low levels, such as microphone signals and when using long cables.

In a professional environment, therefore, the balanced transmission is preferred, because this enables an undisturbed transmission of signals over long distances. In addition to the conductors 'Ground' and 'Signal', in a balanced transmission a second core is added. This also transfers the signal, but phase-shifted by 180°.

Since the interference affects both cores equally, by subtracting the phase-shifted signals, the interfering signal is completely neutralized. The result is a pure signal without any noise interference.

1/4" TS phone plug (mono, unbalanced)



1	Signal
2	Ground, shielding

1/4" TRS phone plug (mono, balanced)



1	Signal (in phase, +)
2	Signal (out of phase, -)
3	Ground

XLR plug (balanced)

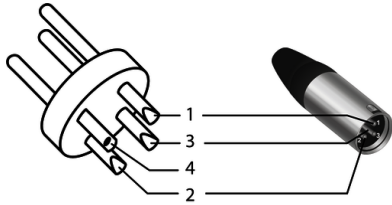

1	Ground, shielding
2	Signal (in phase, +)
3	Signal (out of phase, -)
4	Shielding on plug housing (option)

RCA connection



Drawing and table indicate the pin assignment of an RCA plug.

1	Signal
2	Ground, shielding

8 Protecting the environment

Disposal of the packaging material



For the transport and protective packaging, environmentally friendly materials have been chosen that can be supplied to normal recycling.

Ensure that plastic bags, packaging, etc. are properly disposed of.

Do not just dispose of these materials with your normal household waste, but make sure that they are collected for recycling. Please follow the notes and markings on the packaging.

Disposal of your old device



This product is subject to the European Waste Electrical and Electronic Equipment Directive (WEEE) in its currently valid version. Do not dispose with your normal household waste.

Dispose of this device through an approved waste disposal firm or through your local waste facility. When discarding the device, comply with the rules and regulations that apply in your country. If in doubt, consult your local waste disposal facility.



