



**furgeneration**

PicoBeam 60  
COB RGBW  
moving head

Musikhaus Thomann  
Thomann GmbH  
Hans-Thomann-Straße 1  
96138 Burgebrach  
Germany  
Telephone: +49 (0) 9546 9223-0  
E-mail: [info@thomann.de](mailto:info@thomann.de)  
Internet: [www.thomann.de](http://www.thomann.de)

19.03.2021, ID: 442853 (V3)

# Table of contents

<b>1</b>	<b>General information.....</b>	<b>5</b>
	1.1 Further information.....	6
	1.2 Notational conventions.....	7
	1.3 Symbols and signal words.....	7
<b>2</b>	<b>Safety instructions.....</b>	<b>10</b>
<b>3</b>	<b>Features.....</b>	<b>15</b>
<b>4</b>	<b>Installation.....</b>	<b>17</b>
<b>5</b>	<b>Starting up.....</b>	<b>22</b>
<b>6</b>	<b>Connections and controls.....</b>	<b>25</b>
<b>7</b>	<b>Operating.....</b>	<b>31</b>
	7.1 Starting the device.....	31
	7.2 Main menu.....	32
	7.3 Functions in 3-channel DMX mode.....	41
	7.4 Functions in 8-channel DMX mode.....	42
	7.5 Functions in 13-channel DMX mode.....	44

<b>8</b>	<b>Technical specifications.....</b>	<b>48</b>
<b>9</b>	<b>Plug and connection assignments.....</b>	<b>51</b>
<b>10</b>	<b>Troubleshooting.....</b>	<b>52</b>
<b>11</b>	<b>Cleaning.....</b>	<b>54</b>
<b>12</b>	<b>Protecting the environment.....</b>	<b>55</b>

# 1 General information

This user manual contains important information on the safe operation of the device. Read and follow all safety notes and all instructions. Save this manual for future reference. Make sure that it is available to all persons using this device. If you sell the device to another user, be sure that they also receive this manual.

Our products and user manuals are subject to a process of continuous development. We therefore reserve the right to make changes without notice. Please refer to the latest version of the user manual which is ready for download under [www.thomann.de](http://www.thomann.de).

## 1.1 Further information

On our website ([www.thomann.de](http://www.thomann.de)) you will find lots of further information and details on the following points:

Download	This manual is also available as PDF file for you to download.
Keyword search	Use the search function in the electronic version to find the topics of interest for you quickly.
Online guides	Our online guides provide detailed information on technical basics and terms.
Personal consultation	For personal consultation please contact our technical hotline.
Service	If you have any problems with the device the customer service will gladly assist you.

## 1.2 Notational conventions

This manual uses the following notational conventions:

### Letterings

The letterings for connectors and controls are marked by square brackets and italics.

**Examples:** *[VOLUME]* control, *[Mono]* button.

### Displays

Texts and values displayed on the device are marked by quotation marks and italics.



**Examples:** *'24ch'*, *'OFF'*.

## 1.3 Symbols and signal words

In this section you will find an overview of the meaning of symbols and signal words that are used in this manual.

Signal word	Meaning
<b>DANGER!</b>	This combination of symbol and signal word indicates an immediate dangerous situation that will result in death or serious injury if it is not avoided.
<b>WARNING!</b>	This combination of symbol and signal word indicates a possible dangerous situation that can result in death or serious injury if it is not avoided.
<b>CAUTION!</b>	This combination of symbol and signal word indicates a possible dangerous situation that can result in minor injury if it is not avoided.
<b>NOTICE!</b>	This combination of symbol and signal word indicates a possible dangerous situation that can result in material and environmental damage if it is not avoided.
Warning signs	Type of danger
	Warning – high-voltage.



Warning signs	Type of danger
	<p>Warning – dangerous optical radiation.</p>
	<p>Warning – suspended load.</p>
	<p>Warning – danger zone.</p>

## 2 Safety instructions

### Intended use

This device is intended for use as a freely moving multifunctional spotlight. The device is designed for professional use and is not suitable for use in households. Use the device only as described in this user manual. Any other use or use under other operating conditions is considered to be improper and may result in personal injury or property damage. No liability will be assumed for damages resulting from improper use.

This device may be used only by persons with sufficient physical, sensorial, and intellectual abilities and having corresponding knowledge and experience. Other persons may use this device only if they are supervised or instructed by a person who is responsible for their safety.



*Extend the operating life of the device by regular breaks and by avoiding frequent switching on and off. The device is not suitable for continuous operation.*

**Safety**



**DANGER!**

**Danger for children**

Ensure that plastic bags, packaging, etc. are disposed of properly and are not within reach of babies and young children. Choking hazard! Ensure that children do not detach any small parts (e.g. knobs or the like) from the unit. They could swallow the pieces and choke! Never let children unattended use electrical devices.



**DANGER!**

**Electric shock caused by high voltages inside**

Within the device there are areas where high voltages may be present. Never remove any covers. There are no user-serviceable parts inside. Do not use the device if covers, protectors or optical components are missing or damaged.



**DANGER!**

**Electric shock caused by short-circuit**

Always use proper ready-made insulated mains cabling (power cord) with a protective contact plug. Do not modify the mains cable or the plug. Failure to do so could result in electric shock/death or fire. If in doubt, seek advice from a registered electrician.



**WARNING!**

**Eye damage caused by high light intensity**

Never look directly into the light source.



**WARNING!**

**Risk of epileptic shock**

Strobe lighting can trigger seizures in photosensitive epilepsy. Sensitive persons should avoid looking at strobe lights.



**WARNING!**

**Risk of injury caused by falling objects**

Make sure that the installation complies with the standards and rules that apply in your country. Always secure the device with a secondary safety attachment, such as a safety cable or a safety chain. The load capacity of trusses or other fixtures must be sufficient for the intended number of devices. Note that the movement of the head places additional loads on the load-bearing parts.



**CAUTION!**

**Risk of injury due to movements of the device**

The head of the device can move quickly (pan, tilt) and can produce very bright light. This is also valid immediately after you turn on the device, when the device operates in automatic mode or under remote control and when you turn off a DMX controller that is connected to the device. Persons staying near the device could be injured or frightened. Before you turn on the device and during the operation, always ensure that nobody stays close to the device. If work has to be performed in the area of movement or in the near vicinity of the device, it must remain turned off.



**NOTICE!**

**Risk of fire**

Do not block areas of ventilation. Do not install the device near any direct heat source. Keep the device away from naked flames.

**NOTICE!****Operating conditions**

This device has been designed for indoor use only. To prevent damage, never expose the device to any liquid or moisture. Avoid direct sunlight, heavy dirt, and strong vibrations. Only operate the device within the ambient conditions specified in the chapter 'Technical specifications' of this user manual. Avoid heavy temperature fluctuations and do not switch the device on immediately after it was exposed to temperature fluctuations (for example after transport at low outside temperatures). Dust and dirt inside can damage the unit. When operated in harmful ambient conditions (dust, smoke, nicotine, fog, etc.), the unit should be maintained by qualified service personnel at regular intervals to prevent overheating and other malfunction. The device must not be moved during use.

**NOTICE!****Power supply**

Before connecting the device, ensure that the input voltage (AC outlet) matches the voltage rating of the device and that the AC outlet is protected by a residual current circuit breaker. Failure to do so could result in damage to the device and possibly injure the user. Unplug the device before electrical storms occur and when it is unused for long periods of time to reduce the risk of electric shock or fire.

**NOTICE!****Possible damage due to installation of a wrong fuse**

The use of different types of fuses can cause serious damage to the unit. Fire hazard! Only fuses of the same type may be used.



### **NOTICE!**

#### **Possible staining**

The plasticiser contained in the rubber feet of this product may possibly react with the coating of your parquet, linoleum, laminate or PVC floor and after some time cause permanent dark stains. In case of doubt, do not put the rubber feet directly on the floor, but use felt-pad floor protectors or a carpet.

## 3 Features

Special features of the device:

- Two moving axes
  - Tilt (180°)
  - Pan (540°)
- Pan and Tilt invertible
- 1 × 60 W High Performance RGBW QuadColour COB LED
- RGBW colour mixing
- Very narrow beam angle of only 4°
- Control via DMX (3, 8 or 13 channels) and via buttons and display on the unit
- Master / Slave mode
- Automatic mode with 5 preprogrammed shows
- Sound control
- Electronic dimmer 0 %...100 %
- Shutter frequency 0...25 Hz
- Omega bracket, infrared remote control and 1 m power cord included

For technological reasons, the light output of LEDs decreases over their lifetime. This effect increases with higher operating temperature. You can extend the service life of the illuminants by providing adequate ventilation and operating the LEDs with the lowest possible brightness.



## 4 Installation

Unpack and check carefully there is no transportation damage before using the unit. Keep the equipment packaging. To fully protect the product against vibration, dust and moisture during transportation or storage use the original packaging or your own packaging material suitable for transport or storage, respectively.



### **WARNING!**

#### **Risk of injury caused by falling objects**

Make sure that the installation complies with the standards and rules that apply in your country. Always secure the device with a secondary safety attachment, such as a safety cable or a safety chain.

The load capacity of trusses or other fixtures must be sufficient for the intended number of devices. Note that the movement of the head places additional loads on the load-bearing parts.



## **CAUTION!**

### **Risk of injury due to movements of the device**

The head of the device can move quickly (pan, tilt) and can produce very bright light. This is also valid immediately after you turn on the device, when the device operates in automatic mode or under remote control and when you turn off a DMX controller that is connected to the device. Persons staying near the device could be injured or frightened.

Before you turn on the device and during the operation, always ensure that nobody stays close to the device. If work has to be performed in the area of movement or in the near vicinity of the device, it must remain turned off.



## **NOTICE!**

### **Risk of overheating**

The distance between light output and the illuminated surface must be more than 1.5 m (19.7in).

Provide sufficient ventilation.

The ambient temperature must always be below 40 °C (104 °F).



**NOTICE!**

**Possible damage caused by movements of the device**

Always ensure that enough space is free around the device for the movements of the head (pan, tilt).



**NOTICE!**

**Possible data transmission errors**

For error-free operation make use of dedicated DMX cables and do not use ordinary microphone cables.

Never connect the DMX input or output to audio devices such as mixers or amplifiers.



*Please note that this device must not be connected to a dimmer.*

## Mounting options

You can install the device on the wall, the ceiling or on the floor.

The threads on the housing bottom are used to secure the supplied Omega bracket or truss clamps.

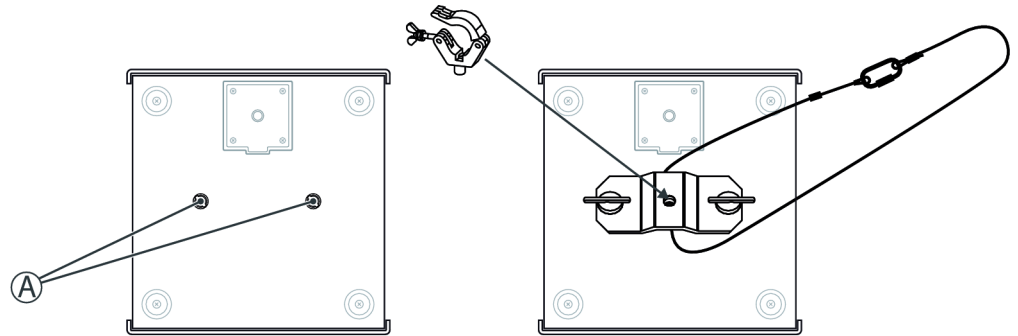

### Inserting the battery into the remote control

Press the lock of the battery holder to the centre of the housing and pull out the battery holder like a drawer. Insert the battery. The battery is correct if the positive pole points to the housing base of the remote control. Slide the battery holder back into the remote until it clicks into place.

When shipping, the battery is already installed in the remote and protected against discharge by a transparent plastic foil. Remove the plastic foil prior to first use.

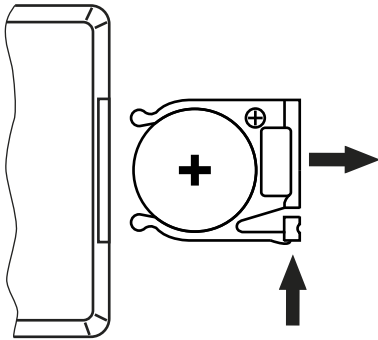

## 5 Starting up

Create all connections while the device is off. Use the shortest possible high-quality cables for all connections. Take care when running the cables to prevent tripping hazards.

**Connections in DMX mode**

Connect the DMX input of the device to the DMX output of a DMX controller or another DMX device. Connect the output of the first DMX device to the input of the second one, and so on to form a daisy chain. Always ensure that the output of the last DMX device in the daisy chain is terminated with a resistor ( $110\ \Omega$ ,  $\frac{1}{4}\ \text{W}$ ).

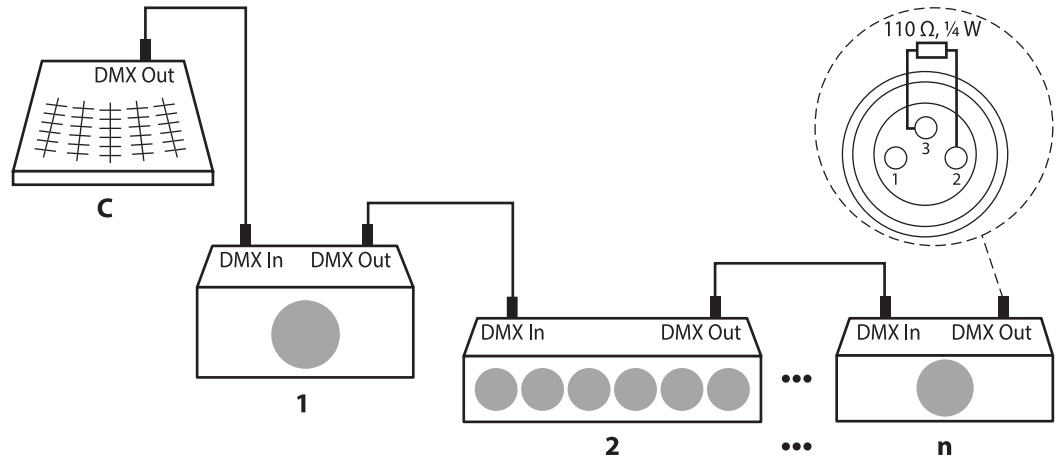

### **Connections in master/slave mode**

When you configure a group of devices in master/slave mode, the first unit will control the other units for an automatic, sound-activated, synchronized show. This function is ideal when you want to start a show immediately. Connect the DMX output of the master device to the DMX input of the first slave device. Then connect the DMX output of the first slave device to the DMX input of the second slave device and so on.



## 6 Connections and controls

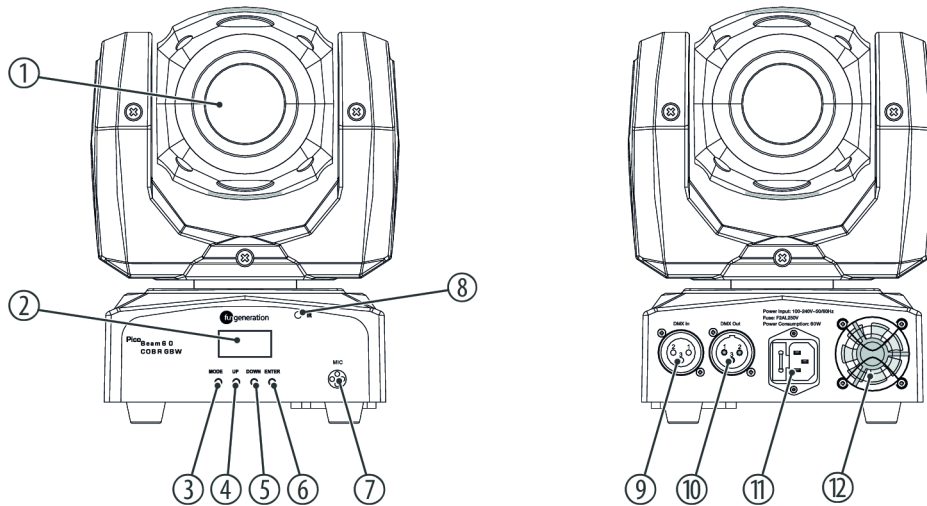

PicoBeam 60 COB RGBW

1	Light aperture
2	Display
3	<i>[MODE]</i> Calls up the settings menu, skips one menu level back and closes an opened submenu without saving any changes.
4	<i>[UP]</i> Increases the displayed value by one and selects menu items.
5	<i>[DOWN]</i> Decreases the displayed value by one and selects menu items.
6	<i>[ENTER]</i> Calls up the menu for the respective operation mode, confirms a set value.
7	Microphone for sound control.
8	Infrared sensor for receiving remote control signals.
9	<i>[DMX In]</i> DMX input

10	<i>[DMX Out]</i> DMX output
11	IEC chassis plug for the mains cable with fuse holder.
12	Fan

## Infrared remote (optionally available)

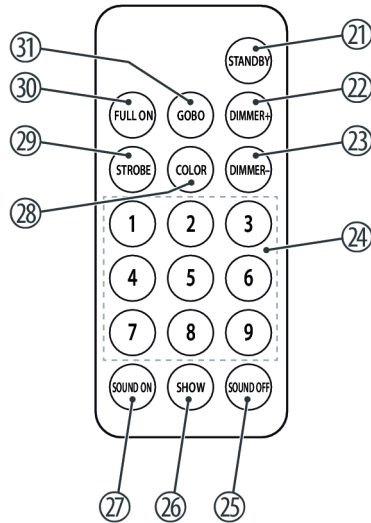

To use the remote control, point its infrared diode at the infrared sensor on the unit and press the desired buttons. The maximum operating distance is about 9 m. The device will only respond to the remote control signals if it is not controlled via DMX.

To enable the operation via remote control, press *[STAND BY]* on the remote control and then *[FULL ON]*.

21	<i>[STAND BY]</i> Stops the automatic mode and blackouts the unit. The display shows 'Stop'. In this mode, the device responds to the remote control.
22, 23	<i>[Dimmer+]</i> / <i>[Dimmer-]</i> Adjusts the light intensity between 0 and 100%. Press <i>[Dimmer +]</i> repeatedly or keep the button pressed to increase the light intensity. Press <i>[Dimmer-]</i> repeatedly or keep the button pressed to decrease the light intensity.
24	Number buttons These buttons allow you to trim the rotation (X) and tilt (Y) of the device head:

	Button 1: X- & Y+	Button 2: Y+	Button 3: X+ & Y+	Button 4: X-	Button 5: Centre	Button 6: X+	Button 7: X- & Y-	Button 8: Y-	Button 9: X+ & Y-
25	<p><i>[SOUND OFF]</i> Deactivates the sound-control.</p>								
26	<p><i>[SHOW]</i> To call up one of the 5 preprogrammed automatic shows, press this button followed by the number button 1 – 5 for the desired show. To cancel a show, press <i>[STAND BY]</i>.</p>								
27	<p><i>[SOUND ON]</i> Activates the sound-control.</p>								
28	<p><i>[COLOR]</i> To call up various colours for the current light scene. Then press one of the number buttons 1 – 4 for the desired colour. 1 for red, 2 for green, 3 for blue, 4 for white. Use <i>[Dimmer + / -]</i> to adjust the intensity.</p>								

29	<i>[STROBE]</i> Enables the Strobe function for the current light scene. Then press one of the number buttons 1– 7 for the desired strobe frequency.
30	<i>[FULL ON]</i> Press this button to call up the programmed light scene.
31	<i>[GOBO]</i> No function.

## 7 Operating

### 7.1 Starting the device



#### **CAUTION!**

#### **Risk of injury due to movements of the device**

The head of the device can move quickly (pan, tilt) and can produce very bright light. This is also valid immediately after you turn on the device, when the device operates in automatic mode or under remote control and when you turn off a DMX controller that is connected to the device. Persons staying near the device could be injured or frightened.

Before you turn on the device and during the operation, always ensure that nobody stays close to the device. If work has to be performed in the area of movement or in the near vicinity of the device, it must remain turned off.

Connect the device to the power supply to start operation. After a few seconds, the fans start to work, the head moves to the home positions for rotation (pan) and inclination (tilt). After some more seconds, 'Addr:001 NoSignal' is flashing in the display. The device is now operational.

## 7.2 Main menu

Press *[MODE]* to activate the main menu. Use *[UP]* or *[DOWN]* to select a submenu. When the display shows the desired submenu press *[ENTER]* to open it up. To close the submenu, press *[MODE]*. Confirm changed values with *[ENTER]*.

The following table shows the setting options.



Main menu	Menu level 2	Menu level 3	Menu level 4
	<b>Meaning</b>		
'DMX menu'	'DMX Addr'	Setting the DMX address	
		'DMX Addr : 001...500/505/510'	
	'Channels Select'	Selecting a DMX mode	
		'3 Chnl Mode'	3-channel DMX mode
		'8 Chnl Mode'	8-channel DMX mode
		'13 Chnl Mode'	13-channel DMX mode
	'DMX Break'	Device behaviour on DMX signal failure	
		'DMX Break : Hold'	Retaining last settings
		'DMX Break : Auto'	Performing an automatic run
		'DMX Break : Sound'	Performing a sound-controlled automatic run

Main menu	Menu level 2	Menu level 3	Menu level 4
Meaning			
		'DMX Break : Stop '	Stop and take starting position
'Set Menu'	'Reload Default'	Resetting the device to factory defaults	
		'On'	Perform
		'Off'	Don't perform
	'Reset Machine'	Reset positions and colours to the respectively programmed parameters	
		'On'	Perform
		'Off'	Don't perform
	'Master & Alone'	Master and Stand-alone operation	
		'Master '	Device works as a master and controls further devices
		'Alone'	Device works in stand-alone mode
	'Auto & Sound'	Auto operation or sound control	
'Auto'		Auto operation	

Main menu	Menu level 2	Menu level 3	Menu level 4
	<b>Meaning</b>		
		'Sound'	Sound control
	'MICSense'	Microphone sensitivity for sound control	
		'00' ... '99', default = 60	
	'Clear Display'	Automatic display shutdown when not in use	
		'Always On'	Display remains on
		'Delay Off'	Display is dimmed after about 25 seconds
	'Key Lock'	Key lock 30 seconds after last keystroke	
		'Lock: On'	Switching on
		'Lock: Off'	Turning off
	'Information'	Device information	
		'LED Date:'	Date and time of production
	'Machine Timer'	Operating hours counter	

Main menu	Menu level 2	Menu level 3	Menu level 4		
Meaning					
		'ThisTime '	Time since last powering on the device in minutes		
		'TotlTime '	Total elapsed operating time in hours		
		'Clear Total '	Reset previous operating time to zero. Use [UP] and [DOWN] to enter the password to delete the entire previous operating time. Upon delivery, the password is '001'.		
	'Motor Set'	Behaviour on DMX-controlled motion			
		'Move BlackOut '	LED 'off' on DMX-controlled motion	On	
				Off	
	'Motor Calibrate '	Calibration of the motors for rotation and inclination	Pan Motor	Origin	
				HalfStep	
				Test	
				Reset	

Main menu	Menu level 2	Menu level 3	Menu level 4			
Meaning						
					Reverse	
				Tilt Motor	Origin	
					HalfStep	
					Test	
					Reset	
					Reverse	
	'Record Scene'	Recording scenes The displayed names of the colours serve as the names of the scenes.				
		'Red'				
		'Green'				
		'Blue'				
		'White'				
		'Yellow'				

Main menu	Menu level 2	Menu level 3	Menu level 4	
	<b>Meaning</b>			
		'Cyan'		
		'Purple'		
		'AllWhite'		
'Red Alone'	Scene 'Red'			
	'Scene Menu'	Specifying parameters		
		'Dimmer'	'000' ... '255'	Brightness (0 % to 100 %)
		'Strobe'	'000' ... '255'	Strobe effect with increasing speed
		'PanMSB'	'000' ... '255'	Rough adjustment for rotation (pan)
		'PanLSB'	'000' ... '255'	Fine adjustment for rotation (pan)
		'PanSPD'	'000' ... '255'	Rotation (pan) speed
		'TiltMSB'	'000' ... '255'	Rough adjustment for inclination (tilt)
		'TiltLSB'	'000' ... '255'	Fine adjustment for inclination (tilt)

Main menu	Menu level 2	Menu level 3	Menu level 4
	<b>Meaning</b>		
		<i>'TiltSPD'</i>	<i>'000' ... '255'</i> Inclination (tilt) speed
		<i>'ColMacro'</i>	<i>'000' ... '255'</i> Colour Macro
		<i>'Red'</i>	<i>'000' ... '255'</i> Intensity red (0 % to 100 %)
		<i>'Green'</i>	<i>'000' ... '255'</i> Intensity green (0 % to 100 %)
		<i>'Blue'</i>	<i>'000' ... '255'</i> Intensity blue (0 % to 100 %)
		<i>'White'</i>	<i>'000' ... '255'</i> Intensity white (0 % to 100 %)
	<i>'Set Menu'</i>	Saving the parameters, selection option according to <i>'Scene Menu'</i>	
<i>'Green Alone'</i>	Scene <i>'Green'</i> , submenus and selection options according to scene <i>'Red'</i>		
<i>'Blue Alone'</i>	Scene <i>'Blue'</i> , submenus and selection options according to scene <i>'Red'</i>		
<i>'White Alone'</i>	Scene <i>'White'</i> , submenus and selection options according to scene <i>'Red'</i>		
<i>'Yellow Alone'</i>	Scene <i>'Yellow'</i> , submenus and selection options according to scene <i>'Red'</i>		
<i>'Cyan Alone'</i>	Scene <i>'Cyan'</i> , submenus and selection options according to scene <i>'Red'</i>		

Main menu	Menu level 2	Menu level 3	Menu level 4	
	<b>Meaning</b>			
'Purple Alone'	Scene 'Purple', submenus and selection options according to scene 'Red'			
'AllWhite Alone'	Scene 'AllWhite', submenus and selection options according to scene 'Red'			
'Prog 1 Alon Aut'	Automatic show no. 1			
	'Program Menu'	Specifying parameters		
		'Speed'	'000' ... '255'	Running speed
		'Dimmer'	'000' ... '255'	Brightness (0 % to 100 %)
		'Strobe'	'000' ... '255'	Strobe effect with increasing speed
'Set Menu'	Saving the parameters, selection option according to 'Scene Menu'			
'Prog 2 Alon Aut'	Automatic show no. 2, submenus and selection options according to no. 1			
'Prog 3 Alon Aut'	Automatic show no. 3, submenus and selection options according to no. 1			
'Prog 4 Alon Aut'	Automatic show no. 4, submenus and selection options according to no. 1			



Main menu	Menu level 2	Menu level 3	Menu level 4
	<b>Meaning</b>		
'Prog 5 Alon Aut'	Automatic show no. 5, submenus and selection options according to no. 1		
'Sound Alone'	Sound-controlled automatic show, submenus and selection options according to no. 1		

### 7.3 Functions in 3-channel DMX mode

Channel	Value	Function
1	0...255	Rotation (pan) (0° up to the maximum value of the Pan range of 540°)
2	0...255	Inclination (tilt) (0° up to the maximum value of the Tilt range of 180°)
3	0...255	Master dimmer 0 – 100%

## 7.4 Functions in 8-channel DMX mode

Channel	Value	Function	
1	0...255	Rotation (pan) (0° up to the maximum value of the Pan range of 540°)	
2	0...255	Fine adjustment rotation (pan)	
3	0...255	Inclination (tilt) (0° up to the maximum value of the Tilt range of 180°)	
4	0...255	Fine adjustment inclination (tilt)	
5	0...255	Motor speed (fast to slow)	
6	0...255	Master dimmer 0 – 100%	
7	0...255	Programmes	
		000...049	No function
		050...059	Red
		060...069	Green
		070...079	Blue

Channel	Value	Function
	080...089	White
	090...099	Yellow
	100...109	Cyan
	110...119	Purple
	120...129	All white
	130...139	dark
	140...149	Programme 1
	150...159	Programme 2
	160...169	Programme 3
	170...179	Programme 4
	180...189	Programme 5
	190...233	No function
	234...236	Reset

Channel	Value	Function	
		237...249	No function
		250...255	Sound control
8	0...255	000...255	Speed / Sensitivity

## 7.5 Functions in 13-channel DMX mode

Channel	Value	Function
1	0...255	Rotation (pan) (0° up to the maximum value of the Pan range of 540°)
2	0...255	Fine adjustment rotation (pan)
3	0...255	Inclination (tilt) (0° up to the maximum value of the Tilt range of 180°)
4	0...255	Fine adjustment inclination (tilt)

Channel	Value	Function	
5	0...255	Motor speed (fast to slow)	
6	0...255	Master dimmer 0 – 100%	
7	0...255	000...009	no function (open)
		010...255	Strobe effect (1 Hz...25 Hz)
8	0...255	Intensity red	
9	0...255	Intensity green	
10	0...255	Intensity blue	
11	0...255	Intensity white	
12	0...255	Programmes	
		000...049	No function
		050...059	Red
		060...069	Green
		070...079	Blue

Channel	Value	Function
	080...089	White
	090...099	Yellow
	100...109	Cyan
	110...119	Purple
	120...129	All white
	130...139	No function
	140...149	Programme 1
	150...159	Programme 2
	160...169	Programme 3
	170...179	Programme 4
	180...189	Programme 5
	190...233	No function
	234...236	Reset

Channel	Value	Function	
		237...249	No function
		250...255	Sound control
13	0...255	000...255	Speed / Sensitivity

## 8 Technical specifications

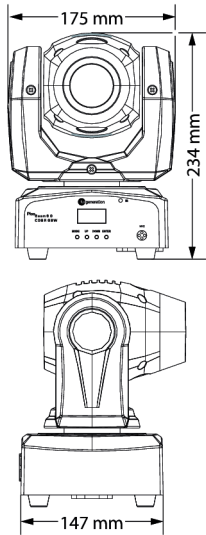

Light source	1 × 60 W High Performance RGBW QuadColour COB LED	
Light source properties	Colour temperature	R620, G520, B450, W8000
	Colour rendering index	CRI (70)
Optical properties	Beam angle	4°
Rotation angle (pan), max.	540°	
Inclination angle (tilt), max.	180°	
Control protocol	DMX512	
Control	DMX, via buttons and display on the unit, infrared remote control	
Number of DMX channels	3, 8 or 13	
Input connections	Power supply	IEC chassis plug C14
	DMX control	XLR chassis socket, 3-pin



Output connections	DMX control	XLR chassis socket, 3-pin
Power consumption	65 W	
Supply voltage	100 – 240 V ~ , 50/60 Hz	
Fuse	5 mm × 20 mm, 2 A, 250 V, fast-acting	
Degree of protection	IP20	
Mounting options	Hanging, standing	
Dimensions (W × H × D), when light beam pointing horizontally	175 mm × 234 mm × 147 mm	
Weight	3 kg	
Ambient conditions	Temperature range	0 °C...40 °C
	Relative humidity	20 % – 80 %, non-condensing

### Further information

Type	Beam
Colour mixture	RGBW
Motorized zoom	No
Motorized focus	No
Rotating gobos	No
Static gobos	No
Number of colour wheels	0
Iris	No
Prism	No

# 9 Plug and connection assignments

## Introduction

This chapter will help you select the right cables and plugs to connect your valuable equipment so that a perfect light experience is guaranteed.

Please take our tips, because especially in 'Sound & Light' caution is indicated: Even if a plug fits into a socket, the result of an incorrect connection may be a destroyed DMX controller, a short circuit or 'just' a not working light show!

## DMX connections



The unit offers a 3-pin XLR socket for DMX output and a 3-pin XLR plug for DMX input. Please refer to the drawing and table below for the pin assignment of a suitable XLR plug.

Pin	Configuration
1	Ground, shielding
2	Signal inverted (DMX-, 'cold signal')
3	Signal (DMX+, 'hot signal')

## 10 Troubleshooting



### **NOTICE!**

#### **Possible data transmission errors**

For error-free operation make use of dedicated DMX cables and do not use ordinary microphone cables.

Never connect the DMX input or output to audio devices such as mixers or amplifiers.

In the following we list a few common problems that may occur during operation. We give you some suggestions for easy troubleshooting:

Symptom	Remedy
The unit does not work, no light, the fan does not run	Check the mains connection and the main fuse.
No response to the DMX controller	1. Check the DMX connectors and cables for proper connection.
	2. Check the address settings and the DMX polarity.
	3. Try using another DMX controller.
	4. Check to see if the DMX cables run near or alongside to high voltage cables that may cause damage or interference to DMX interface circuits.

If the procedures recommended above do not succeed, please contact our Service Center. You can find the contact information at [www.thomann.de](http://www.thomann.de).

## 11 Cleaning

### Optical lenses

Clean the optical lenses, that are accessible from the outside, regularly in order to optimize the light output. The frequency of cleaning depends on the operating environment: wet, smoky or particularly dirty surroundings can cause more accumulation of dirt on the optics of the device.

- Clean with a soft cloth using our lamp and lens cleaner (item no. 280122).
- Always dry the parts carefully.

### Fan grids

The fan grids of the device must be cleaned of any contamination, such as dust, etc. on a regular basis. Before cleaning, switch off the device and disconnect mains-operated devices from the mains. Only use pH-neutral, solvent-free and non-abrasive cleaning agents. Clean the unit with a slightly damp lint-free cloth.

## 12 Protecting the environment

### Disposal of the packaging material



For the transport and protective packaging, environmentally friendly materials have been chosen that can be supplied to normal recycling.

Ensure that plastic bags, packaging, etc. are properly disposed of.

Do not just dispose these materials with your normal household waste, but make sure that they are fed to a recovery. Please follow the notes and markings on the packaging.

### Disposal of batteries



Batteries must not be disposed of as domestic waste or thrown into fire. Dispose of the batteries according to national or local regulations regarding hazardous waste. To protect the environment, dispose of empty batteries at your retail store or at appropriate collection sites.

### Disposal of your old device



This product is subject to the European Waste Electrical and Electronic Equipment Directive (WEEE) in its currently valid version. Do not dispose with your normal household waste.

Dispose this device through an approved waste disposal firm or through your local waste facility. When discarding the device, comply with the rules and regulations that apply in your country. If in doubt, consult your local waste disposal facility.



PicoBeam 60 COB RGBW





