

**the
t.bone**

GigA Pro Wind Set
wireless system



Musikhaus Thomann
Thomann GmbH
Hans-Thomann-Straße 1
96138 Burgebrach
Germany
Telephone: +49 (0) 9546 9223-0
E-mail: info@thomann.de
Internet: www.thomann.de

16.04.2021, ID: 453984 (V3)

Table of contents

1	General information	5
	1.1 Further information.....	6
	1.2 Notational conventions.....	7
	1.3 Symbols and signal words.....	9
2	Safety instructions	11
3	Features	14
4	Installation and starting up	17
	4.1 General Information.....	17
	4.2 Dealing with lithium batteries.....	19
	4.3 Receiver.....	20
5	Connections and controls	22
	5.1 Receiver.....	22
	5.2 Clip-On Microphone.....	29
	5.3 Transmitter.....	31
	5.4 Rechargeable battery station.....	32

6	Operating.....	34
6.1	Receiver.....	34
6.2	Transmitter.....	43
7	Technical specifications.....	45
7.1	Receiver.....	45
7.2	Clip-On Microphone.....	47
7.3	Transmitter.....	48
7.4	Rechargeable battery station.....	49
8	Plug and connection assignment.....	51
9	Troubleshooting.....	54
10	Protecting the environment.....	56

1 General information

This user manual contains important information on the safe operation of the device. Read and follow all safety notes and all instructions. Save this manual for future reference. Make sure that it is available to all persons using this device. If you sell the device to another user, be sure that they also receive this manual.

Our products and user manuals are subject to a process of continuous development. We therefore reserve the right to make changes without notice. Please refer to the latest version of the user manual which is ready for download under www.thomann.de.

1.1 Further information

On our website (www.thomann.de) you will find lots of further information and details on the following points:

Download	This manual is also available as PDF file for you to download.
Keyword search	Use the search function in the electronic version to find the topics of interest for you quickly.
Online guides	Our online guides provide detailed information on technical basics and terms.
Personal consultation	For personal consultation please contact our technical hotline.
Service	If you have any problems with the device the customer service will gladly assist you.

1.2 Notational conventions

This manual uses the following notational conventions:

Letterings

The letterings for connectors and controls are marked by square brackets and italics.

Examples: *[VOLUME]* control, *[Mono]* button.

Displays

Texts and values displayed on the device are marked by quotation marks and italics.

Examples: *'24ch'*, *'OFF'*.

Instructions

The individual steps of an instruction are numbered consecutively. The result of a step is indented and highlighted by an arrow.

Example:

1. ▶ Switch on the device.
2. ▶ Press *[Auto]*.
 - ⇒ Automatic operation is started.
3. ▶ Switch off the device.

Cross-references

References to other locations in this manual are identified by an arrow and the specified page number. In the electronic version of the manual, you can click the cross-reference to jump to the specified location.

Example: See ↗ *'Cross-references'* on page 8.

1.3 Symbols and signal words

In this section you will find an overview of the meaning of symbols and signal words that are used in this manual.

Signal word	Meaning
DANGER!	This combination of symbol and signal word indicates an immediate dangerous situation that will result in death or serious injury if it is not avoided.
WARNING!	This combination of symbol and signal word indicates a possible dangerous situation that can result in death or serious injury if it is not avoided.
NOTICE!	This combination of symbol and signal word indicates a possible dangerous situation that can result in material and environmental damage if it is not avoided.

Warning signs	Type of danger
	Warning – danger zone.

2 Safety instructions

Intended use

This device is intended to be used for the wireless transmission of audio signals from microphones or instruments to amplifiers or active speakers. Use the device only as described in this user manual. Any other use or use under other operating conditions is considered to be improper and may result in personal injury or property damage. No liability will be assumed for damages resulting from improper use.

This device may be used only by persons with sufficient physical, sensorial, and intellectual abilities and having corresponding knowledge and experience. Other persons may use this device only if they are supervised or instructed by a person who is responsible for their safety.

Safety



DANGER!

Danger for children

Ensure that plastic bags, packaging, etc. are disposed of properly and are not within reach of babies and young children. Choking hazard! Ensure that children do not detach any small parts (e.g. knobs or the like) from the unit. They could swallow the pieces and choke! Never let children unattended use electrical devices.



WARNING!

Incorrect handling of lithium batteries can result in injury

In the event of a short circuit, overheating or mechanical damage, lithium batteries can cause severe injuries. Follow the advice on the correct handling of lithium batteries in the present section.



NOTICE!

Operating conditions

This device has been designed for indoor use only. To prevent damage, never expose the device to any liquid or moisture. Avoid direct sunlight, heavy dirt, and strong vibrations. Only operate the device within the ambient conditions specified in the chapter 'Technical specifications' of this user manual. Avoid heavy temperature fluctuations and do not switch the device on immediately after it was exposed to temperature fluctuations (for example after transport at low outside temperatures). Dust and dirt inside can damage the unit. When operated in harmful ambient conditions (dust, smoke, nicotine, fog, etc.), the unit should be maintained by qualified service personnel at regular intervals to prevent overheating and other malfunction.



NOTICE!

External power supply

The device is powered by an external power supply. Before connecting the external power supply, ensure that the input voltage (AC outlet) matches the voltage rating of the device and that the AC outlet is protected by a residual current circuit breaker. Failure to do so could result in damage to the device and possibly the user. Unplug the external power supply before electrical storms occur and when the device is unused for long periods of time to reduce the risk of electric shock or fire.



NOTICE!

Risk of fire due to incorrect polarity



Incorrectly inserted batteries may destroy the device or the batteries. Ensure that proper polarity is observed when inserting batteries.



NOTICE!

Possible damage by leaking batteries



Leaking batteries can cause permanent damage to the device. Take batteries out of the device if it is not going to be used for a longer period.



NOTICE!

Possible damage to lithium-ion batteries through incorrect storage



By deep discharge, lithium-ion batteries can be permanently damaged or lose some of their capacity. Before long breaks, charge the batteries to around 50 % of their capacity and then switch off the device. Store the device at room temperature or cooler in an environment as dry as possible. If the batteries are stored for a longer period, recharge them to 50 % every three months. Fully charge the batteries only shortly before use at room temperature.



NOTICE!

Possible staining



The plasticiser contained in the rubber feet of this product may possibly react with the coating of your parquet, linoleum, laminate or PVC floor and after some time cause permanent dark stains. In case of doubt, do not put the rubber feet directly on the floor, but use felt-pad floor protectors or a carpet.

3 Features

The Wireless System GigA Pro Wind Set consists of the following components:

- 9.5" Diversity receiver:
 - Two antennas for optimum reception quality
 - Automatic frequency scan, eight frequencies in parallel
 - Infrared interface for sending the frequency selection from the receiver to the transmitter (ACT sync)
 - Outputs: XLR, 1/4" jack socket
 - Power supply: 12 V \Rightarrow , a suitable power adapter and mounting accessories for installation in a rack are included in the delivery
- Wind Mic Clip-On Microphone:
 - Gooseneck cardioid microphone to clip on music instruments
 - Condenser capsule (10 mm)
 - Frequency range 65 Hz ... 20 kHz
- Plug On instrument transmitter:
 - Replaceable lithium-ion rechargeable battery operation
 - Charging contacts for battery charging station GigA Pro MP24
 - Three-digit display for battery capacity

- Flexible stub antenna
- Screwed adapter from 3.5 mm to 1/4" jack socket
- Rechargeable battery station MP24

The system operates at 2.400 GHz ... 2.4835 GHz and is worldwide free of charge and registration.

Components and sets

		Vocal Set	Body Set	Pedal Set	Wind Set	Cam Set PT	Cam Set HT
Components	Article	313901	313903	437954	453984	453985	453987
Bodypack Transmitter	314031		x			x	
Bodypack Receiver	453669					x	x
Handheld Transmitter	314033	x					x
Receiver	314034	x	x		x		
GT	453986			x	x		
BC2	398020	x	x				
Wind Mic	454560				x		
Pedal Board Receiver (PBR)*				x			
MP-24 for GT *				x	x		

* not available separately

4 Installation and starting up

4.1 General Information

Unpack and check carefully there is no transportation damage before using the unit. Keep the equipment packaging. To fully protect the product against vibration, dust and moisture during transportation or storage use the original packaging or your own packaging material suitable for transport or storage, respectively.

Create all connections while the device is off. Use the shortest possible high-quality cables for all connections. Take care when running the cables to prevent tripping hazards.

Notes on wireless transmission

- This device utilizes frequencies that are not harmonized within the European Union (EU) and therefore may only be used in certain EU member states. In all European countries, the frequencies used for the transmission of audio signals are strictly regulated. Before you start, make sure the frequencies are allowed in the respective country and check whether the operation must be reported to the appropriate authority.
For more information, please visit: <http://www.thomann.de>.
- Make sure that transmitter and receiver are both tuned to the same channel.
- Never set multiple transmitters to the same channel.
- Make sure that there are no metal objects between the transmitter and receiver.
- Avoid interference from other radio or in-ear systems.

4.2 Dealing with lithium batteries



WARNING!

Incorrect handling of lithium batteries can result in injury

In the event of a short circuit, overheating or mechanical damage, lithium batteries can cause severe injuries.

Follow the advice on the correct handling of lithium batteries in the present section.

When handled correctly and appropriately lithium batteries pose no risk.

Store lithium batteries in a cool, dry place, ideally in the original packaging.

Store lithium batteries away from heat sources (e.g. radiators or sunlight). Lithium batteries are hermetically sealed. Never attempt to open a lithium battery.

If the battery housing is damaged small amounts of the electrolyte may leak out. If this should happen, seal the lithium battery in airtight packaging and wipe up the traces of electrolyte using absorbent paper towels. You must wear protective rubber gloves when doing so. Clean your hands and the affected surface thoroughly with cold water.

Never attempt to recharge non-rechargeable lithium batteries. When charging lithium batteries you must use a suitable charging device intended for the purpose.

Before disposing of the device remove the lithium batteries. Protect used lithium batteries against potential short circuits, e.g. by covering the poles with adhesive tape.

Only use powder extinguishers or other suitable extinguishing agents to extinguish a burning lithium battery.

4.3 Receiver

Rack mounting

The unit has been designed for rack mounting in a standard 19" rack; it occupies one rack unit. The fixing material required for assembly is included.

Connect the voltage supply



NOTICE!

External power supply

The device is powered by an external power supply. Before connecting the external power supply, ensure that the input voltage (AC outlet) matches the voltage rating of the device and that the AC outlet is protected by a residual current circuit breaker. Failure to do so could result in damage to the device and possibly the user.

Unplug the external power supply before electrical storms occur and when the device is unused for long periods of time to reduce the risk of electric shock or fire.

First, connect the power adapter to the receiver and then plug the power adapter into the power outlet.

Connecting audio and starting up

Connect one of the audio outputs of the receiver to your mixer or your amplifier. Ensure that only one of the two outputs is ever used at a time, because faults might occur otherwise.

5 Connections and controls

5.1 Receiver

Front panel

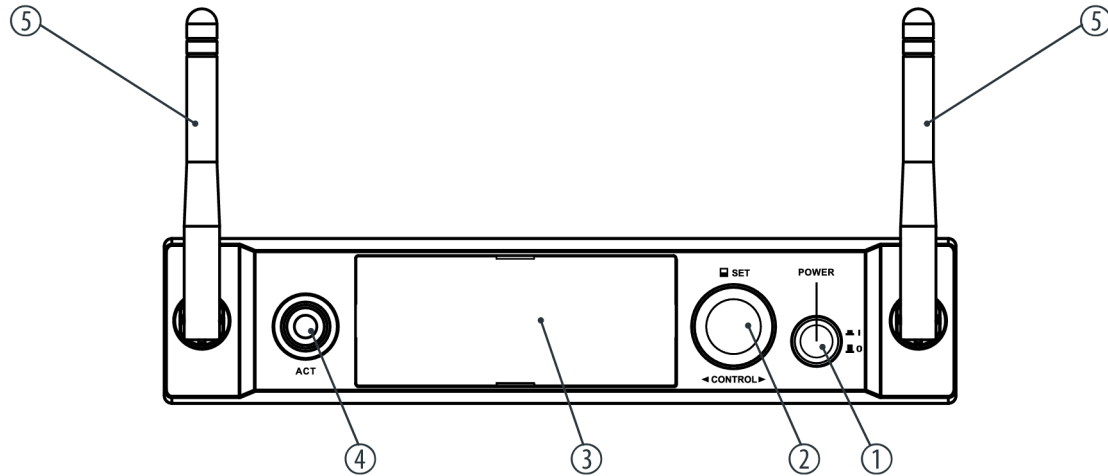

1	<i>[POWER]</i> Press the switch to switch the device on or off. All previous settings are retained even when you switch the device off and disconnect it from the mains.
2	<i>[CONTROL]</i> Press the jog wheel to open the menu and rotate it to select a menu item. Press the jog wheel again to call up the menu item.
3	Display
4	<i>[ACT]</i> Starts the synchronization of the settings with the transmitter.
5	Antenna

Rear panel

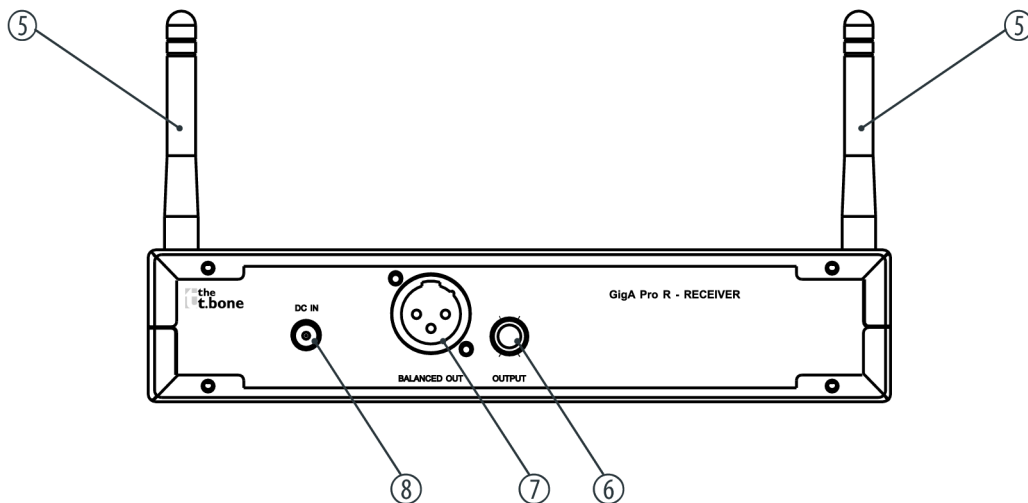

5	Antenna
6	<i>[OUTPUT]</i> 1/4" phone socket as unbalanced audio signal output for direct connection to a mixer, a power amplifier or recording device.
7	<i>[BALANCED OUT]</i> Male XLR panel connector as symmetrical audio signal output for direct connection with a mixer, a power amplifier, or a recording device.
8	<i>[DC IN]</i> Socket for connecting the supplied AC power supply. If you are using a different power supply, observe the correct voltage, the polarity of the plug and the power consumption.

Display

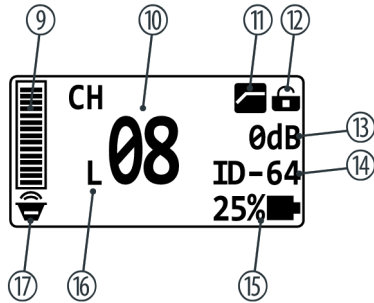

9	Output signal level
10	[CH] Display of the selected channel
11	Bass filter Symbol visible: Bass filter active Symbol invisible: Bass filter not active
12	Write protection Lock icon open: Write protection not active Lock icon closed: Write protection active
13	Gain
14	[ID] Displays the selected ID code

15	Displays the battery status of the transmitter from which the device just received a signal. <i>'10%'</i> : Battery change required <i>'T×OFF'</i> : The transmitter is turned off.
16	Indicates RF power level <i>'L'</i> : low power level <i>'H'</i> : high power level
17	Transmitter status indicator Speaker icon: The transmitter is not muted Speaker icon crossed out: The transmitter is muted

Display during automatic channel evaluation

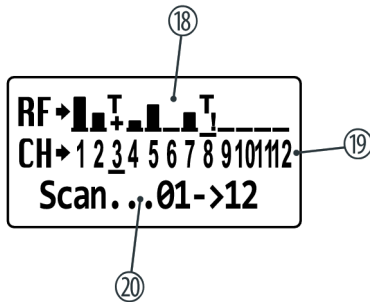

18	'RF'	Current evaluation result. Here, the vertical bars indicate how strong the interferences on the respective channel are. The 'T+' symbol indicates the currently used channel. The 'T!' symbol is displayed for channels that are occupied by other devices. The symbols flash for the channel currently being tested.
19	'CH'	Available channel numbers. The channel currently selected with the jog wheel is highlighted.
20	'Scan'	Scanned channels

5.2 Clip-On Microphone

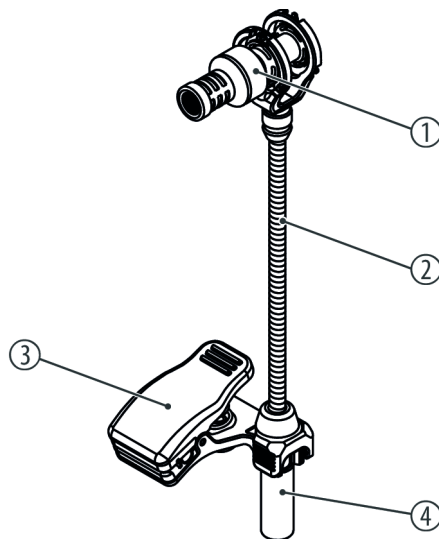

GigA Pro Wind Set

1	Condenser capsule with detachable head grill
2	Flexible gooseneck
3	Clip for fixing the microphone to the instrument
4	3.5 mm mini jack plug with thread for connecting the microphone to the transmitter

5.3 Transmitter

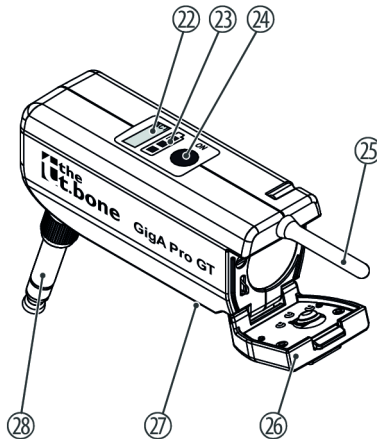

22	[ACT] Infrared sensor
23	Battery status indicator If the last remaining segment lights up red, at most 25% of the battery capacity remains.
24	[ON] Main switch. Press the switch for several seconds to switch the device on or off.
25	Antenna
26	Snap locks for the battery compartment.
27	Charging contacts.
28	Jack socket (mono) for connecting to your instrument You can screw an adapter to a 1/4" jack socket or the supplied connection cable on the 3.5 mm phone plug.

5.4 Rechargeable battery station

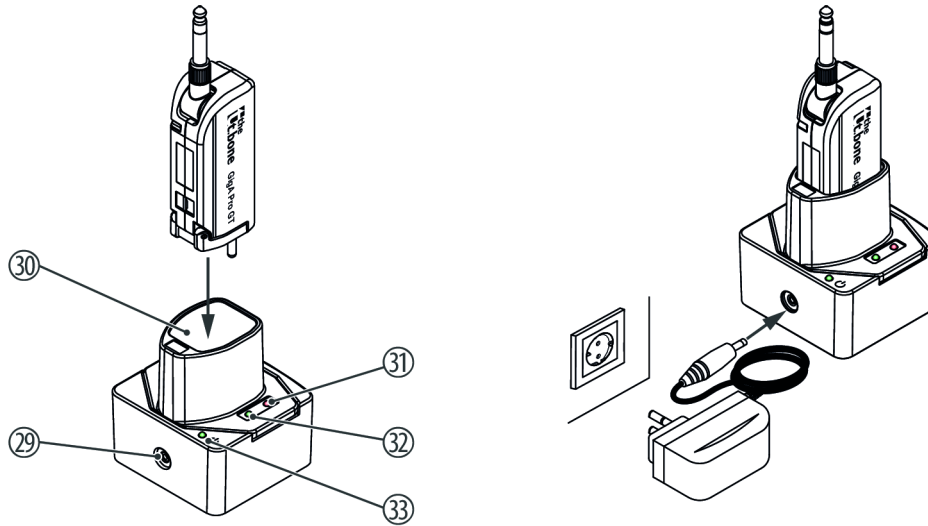

29	Connector for the supplied power supply adapter
30	Charging slot
31.32	Charging indication The red LED lights during charging, while the green LED will light up when the device is charged.
33	Power indicator. Lights up when the device is connected to the power supply.

6 Operating

6.1 Receiver

Switching on the receiver

Requirements: All transmitters are switched off. The volume control of the mixer is set to minimum volume.

- Press *[POWER]* to turn the device on.
- ⇒ The display shows the current settings.

How to navigate in the menu

1. ➤ Press the jog wheel to open the main menu or to open a menu item.
2. ➤ Turn the jog wheel left or right to select a menu item.
3. ➤ Press the jog wheel to call up the selected menu item.
4. ➤ Turn the jog wheel left or right to select a parameter or value.
5. ➤ Press the jog wheel to confirm the selected parameter or value.

6. ▶ Turn the jog wheel left or right to select the menu item '*Exit&Save*'.
7. ▶ Press the jog wheel to to save the settings and return to the home screen.

Selecting channel and ID

In this menu the channel number is selected. The ID adjustable in addition to the channel increases the transmission reliability.

- 1.** ▶ Press the jog wheel to open the main menu.
- 2.** ▶ Turn the jog wheel until the menu item '*Channel&ID*' appears.
Press the jog wheel to call up the menu item.
⇒ The current channel number and ID are displayed. The cursor is positioned on the channel number.
- 3.** ▶ Turn the jog wheel left or right to select the desired channel.
Press the jog wheel to confirm the selection.
⇒ The selected setting is accepted. The cursor is positioned on the ID.
- 4.** ▶ Turn the jog wheel left or right to select the desired ID.
- 5.** ▶ Press the jog wheel to confirm the selection.
- 6.** ▶ Turn the jog wheel left or right to select the menu item '*Exit&Save*'.
- 7.** ▶ Press the jog wheel to to save the settings and return to the home screen.

Gain setting

1. ▶ Press the jog wheel to open the main menu.
2. ▶ Turn the jog wheel until the menu item '*AudioGain*' appears.
Press the jog wheel to call up the menu item.
⇒ The current gain setting is displayed. The cursor is positioned on the dB value.
3. ▶ Turn the jog wheel left or right to select a dB value between -10 dB and +20 dB. The setting is made in steps of 1 dB.
Press the jog wheel to confirm the selection.
4. ▶ Turn the jog wheel left or right to select the menu item '*Exit&Save*'.
5. ▶ Press the jog wheel to to save the settings and return to the home screen.

Enabling / disabling the bass filter

1. ▶ Press the jog wheel to open the main menu.
2. ▶ Turn the jog wheel until the menu item '*LowCut*' appears.
Press the jog wheel to call up the menu item.

- 3.** ▶ Turn the jog wheel left or right to select '*ON*' if you want to activate the bass filter. The filter is used to suppress annoying hum or rumbling noises.
or
Turn the jog wheel left or right to select '*OFF*' if you want to deactivate the bass filter.
Press the jog wheel to confirm the selection.
- 4.** ▶ Turn the jog wheel left or right to select the menu item '*Exit&Save*'.
- 5.** ▶ Press the jog wheel to to save the settings and return to the home screen.

Adjusting radio signal level

1. ▶ Press the jog wheel to open the main menu.
2. ▶ Turn the jog wheel until the menu item '*RFPower*' appears.
Press the jog wheel to call up the menu item.
⇒ The last selected setting is displayed.
3. ▶ Turn the jog wheel left or right to select '*High*' if you want to set a high level.
or
Turn the jog wheel left or right to select '*Low*' if you want to set a low level.
Press the jog wheel to confirm the selection.
4. ▶ Turn the jog wheel left or right to select the menu item '*Exit&Save*'.
5. ▶ Press the jog wheel to to save the settings and return to the home screen.

Automatic channel evaluation

1. ▶ Press the jog wheel to open the main menu.
2. ▶ Turn the jog wheel until the menu item '*ChannelScan*' appears.
Press the jog wheel to start the automatic channel evaluation.
 - ⇒ The evaluation result is displayed. Here, the vertical bars indicate how strong the interferences on the respective channel are. The '*T+*' symbol indicates the currently used channel. The '*T!*' symbol is displayed for channels that are occupied by other devices. The symbols flash for the channel currently being tested.
3. ▶ Turn the jog wheel left or right to select the channel with the least interference.
Press the jog wheel to confirm the selection.
4. ▶ Turn the jog wheel left or right to select the menu item '*Exit&Save*'.
5. ▶ Press the jog wheel to to save the settings and return to the home screen.
6. ▶ Synchronize receiver and transmitter ↻ '*Synchronizing transmitter and receiver*' on page 42.

Enable write protection

The settings of the device can be protected against unintentional changes by a write protection.

1. ▶ Press the jog wheel to open the main menu.
2. ▶ Turn the jog wheel until the menu item *'SetLock'* appears.
Press the jog wheel to call up the menu item.
3. ▶ Turn the jog wheel left or right to select *'NO'* if you do not want to set write protection.
or
Turn the jog wheel left or right to select *'YES'* if you want to set write protection.
Press the jog wheel to confirm the selection.
4. ▶ Turn the jog wheel left or right to select the menu item *'Exit&Save'*.
5. ▶ Press the jog wheel to save the settings and return to the home screen.

Showing firmware version

1. ▶ Press the jog wheel to open the main menu.
2. ▶ Turn the jog wheel until the menu item *'Version?'* appears.
Press the jog wheel to call up the menu item.
⇒ The current firmware version of the device is displayed.

3. ▶ Press the jog wheel to close the display.
4. ▶ Turn the jog wheel left or right to select the menu item '*Exit&Save*'.
5. ▶ Press the jog wheel to return to the home screen.

Synchronizing transmitter and receiver

1. ▶ Turn on the transmitter and point the infrared sensor of the transmitter directly at the *[ACT]* button of the receiver.
2. ▶ Press *[ACT]*.
 - ⇒ The message '*ACT...*' in the display indicates that the synchronization is running.
3. ▶ After successful synchronization, the display appears in the default state. The battery status of the transmitter with which you just synchronized is now displayed here.

If the synchronization has failed, the message '*FAIL*' appears. In this case, hold the transmitter closer to the receiver and restart the synchronization.

6.2 Transmitter

Engaging transmitter

1. ▶ Connect the transmitter to your instrument before switching the transmitter on. If the transmitter should not be connected directly to the instrument, use the screwable extension cable. Use the practical metal clip to fix the transmitter at the guitar strap.
2. ▶ Press *[ON]*.
 - ⇒ The battery level indicator and the button *[AF]* light up.
3. ▶ If the last remaining segment of the battery level indicator lights up red, at most 25 % of the battery capacity remains.

In this case, recharge the transmitter in the charger or replace the empty battery with a charged one.

Turning the transmitter off

Press *[ON]* for several seconds until the battery level indicator goes out.

Battery replacement

1. ▶ Turn the transmitter off.
2. ▶ Press the snap lock forward to open the battery compartment cover.
3. ▶ Remove the empty battery and replace it with a charged one. Observe the correct polarity. The positive pole points into the device in the direction of the phone socket.
4. ▶ Close the battery compartment and turn the transmitter back on.
5. ▶ Should the transmitter also fail to work with a freshly charged battery, turn the transmitter on and off again.

7 Technical specifications

7.1 Receiver

Number of systems that can be operated in parallel	8 systems	
Input connections	Power supply	Connector for power adapter
Output connections	Audio signal	XLR chassis plug, balanced
		1 × 1/4" jack socket (unbalanced)
Output level adjustment	-10 dB ... +20 dB	
Frequency range	2.400 GHz ... 2.4835 GHz	
Sensitivity	-95 dBm	
Total harmonic distortion (THD)	0.1 %	
Signal-to-noise ratio	> 115 dB (A)	
Audio sampling rate	24 bit / 44.1 kHz	

Technical specifications

NF frequency response	20 Hz ... 20 kHz (-2 dB)	
Power consumption	1.6 W	
Power supply	External power adapter, 100 - 240 V ~ 50/60 Hz	
Operating voltage	12 - 15 V $\overline{\text{---}}$ / 1000 mA, centre positive	
Installation	19", 1 RU	
Dimensions (W x H x D, without antennas)	210 mm x 44 mm x 180 mm	
Weight	0.75 kg	
Ambient conditions	Temperature range	0 °C...40 °C
	Relative humidity	20 %...80 % (non-condensing)

7.2 Clip-On Microphone

Polar pattern	Cardioid	
Output connections	3.5 mm mini jack plug with thread	
Frequency range	65 Hz ... 20 kHz	
Sound pressure level (SPL)	142 dB	
Sensitivity	-52 dB	
Dimensions (W × H):	10 mm × 197 mm	
Weight	57 g (incl. capsule, clip and gooseneck)	
Ambient conditions	Temperature range	0 °C...40 °C
	Relative humidity	20 %...80 % (non-condensing)

7.3 Transmitter

Frequency range	2.400 GHz ... 2.4835 GHz	
Max. transmission power	10 mW	
Maximum input level	6.5 dBV	
Input impedance	1,0 MΩ	
Range (free field)	Up to 100 m	
Battery / rechargeable battery	Battery type	1 × lithium-ion rechargeable battery ICR-18500
	Voltage	3.7 V
	Capacity	1400 mAh
	Operating time	> 1 h (after 25 minutes charging time), > 10 h (after four hours charging time)
Dimensions (W × H × D, without antenna)	84 mm × 35 mm × 29 mm	
Weight	61 g	

Ambient conditions	Temperature range	0 °C...40 °C
	Relative humidity	20 %...80 % (non-condensing)

7.4 Rechargeable battery station

Suitable for	Battery type	Lithium-ion rechargeable battery ICR-18500
	Voltage	3.7 V
	Capacity	1400 mAh
Charging current	approx. 500 mA	
Power supply	External power adapter, 100 - 240 V ~ 50/60 Hz	
Operating voltage	5 V $\overline{\text{---}}$ / 1 A, centre positive	
Current consumption	approx. 550 mA	

Technical specifications

Dimensions (W × H × D)	72 mm × 76,5 mm × 68 mm	
Weight	162 g	
Ambient conditions	Temperature range	0 °C...40 °C
	Relative humidity	20 %...80 % (non-condensing)

8 Plug and connection assignment

Introduction

This chapter will help you select the right cables and plugs to connect your valuable equipment in such a way that a perfect sound experience is ensured.

Please note these advices, because especially in 'Sound & Light' caution is indicated: Even if a plug fits into the socket, an incorrect connection may result in a destroyed power amp, a short circuit or 'just' in poor transmission quality!

Balanced and unbalanced transmission

Unbalanced transmission is mainly used in semi-professional environment and in hifi use. Instrument cables with two conductors (one core plus shielding) are typical representatives of the unbalanced transmission. One conductor is ground and shielding while the signal is transmitted through the core.

Unbalanced transmission is susceptible to electromagnetic interference, especially at low levels, such as microphone signals and when using long cables.

In a professional environment, therefore, the balanced transmission is preferred, because this enables an undisturbed transmission of signals over long distances. In addition to the conductors 'Ground' and 'Signal', in a balanced transmission a second core is added. This also transfers the signal, but phase-shifted by 180°.

Since the interference affects both cores equally, by subtracting the phase-shifted signals, the interfering signal is completely neutralized. The result is a pure signal without any noise interference.

1/4" TS phone plug (mono, unbalanced)



1	Signal
2	Ground, shielding

1/4" TRS phone plug (mono, balanced)



1	Signal (in phase, +)
2	Signal (out of phase, -)
3	Ground

**Three-pole 1/8" mini phone jack
(stereo, unbalanced)**



1	Signal (left)
2	Signal (right)
3	Ground, shielding

XLR plug (balanced)

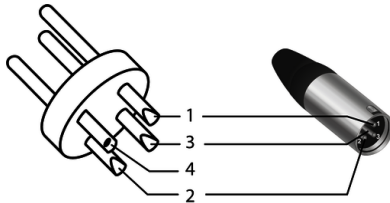

1	Ground, shielding
2	Signal (in phase, +)
3	Signal (out of phase, -)
4	Shielding on plug housing (option)

9 Troubleshooting

In the following we list a few common problems that may occur during operation. We give you some suggestions for easy troubleshooting:

Symptom	Remedy
No sound	1. Check the power supply of transmitter and receiver.
	2. Make sure that transmitter and receiver are operating in the same frequency range. The frequency range can be found on the devices.
	3. Are transmitter and receiver set to the same channel and ID?
	4. Test the connection between the receiver and the connected audio device (amplifier, mixer). Is the connected audio device turned on and does the signal level at the output of the receiver match the input requirements of the audio device?
	5. See if the audio transmission works when you move the transmitter closer to the receiver.

Symptom	Remedy
	6. Make sure that no metal objects near the transmitter or receiver obstruct the transmission.
Transmission is interrupted	1. Modify the orientation of the antennas.
	2. If you use more than one wireless system at the same time, check the used frequencies and channels.
	3. Interference can also be caused by other radio or in-ear systems.

If the procedures recommended above do not succeed, please contact our Service Center. You can find the contact information at www.thomann.de.

10 Protecting the environment

Disposal of the packaging material



For the packaging, environmentally friendly materials have been chosen that can be supplied to normal recycling.

Ensure that plastic bags, packaging, etc. are properly disposed of.

Do not just dispose of these materials with your normal household waste, but make sure that they are collected for recycling. Please follow the notes and markings on the packaging.

Disposal of batteries



Batteries do contain some hazardous chemicals so they should not be thrown away with the normal household waste. They should be returned to the manufacturer for disposal or recycled elsewhere in accordance with your local regulations.

Dispose lithium batteries only in discharged condition. Remove lithium batteries from the device before disposal. Protect used lithium batteries against potential short circuits, e.g. by covering the poles with adhesive tape. Dispose the built-in lithium batteries together with the device. Please check for an appropriate reception facility.

Disposal of your old device



This product is subject to the European Waste Electrical and Electronic Equipment Directive (WEEE) in its currently valid version. Do not dispose with your normal household waste.

Dispose of this device through an approved waste disposal firm or through your local waste facility. When discarding the device, comply with the rules and regulations that apply in your country. If in doubt, consult your local waste disposal facility.



