



PORTABLE PA SYSTEM

# STAGEPAS 1K

Owner's Manual

Mode d'emploi

Manual de instrucciones

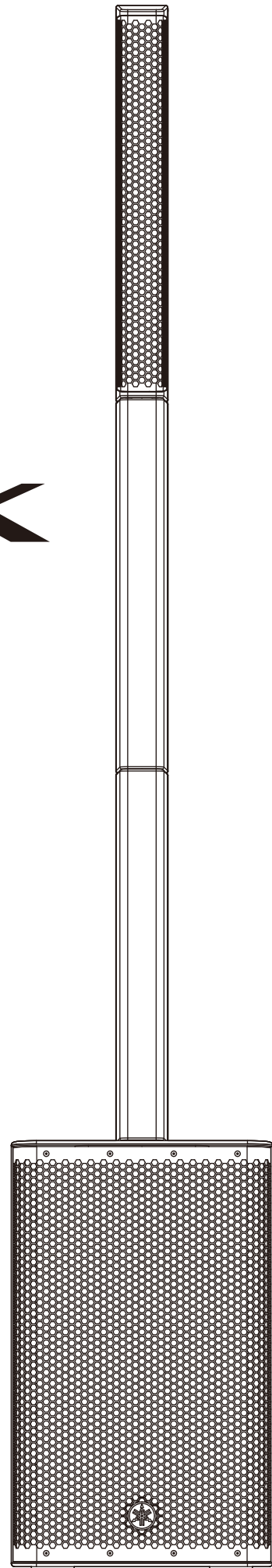

English

Français

Español

EN

FR

ES

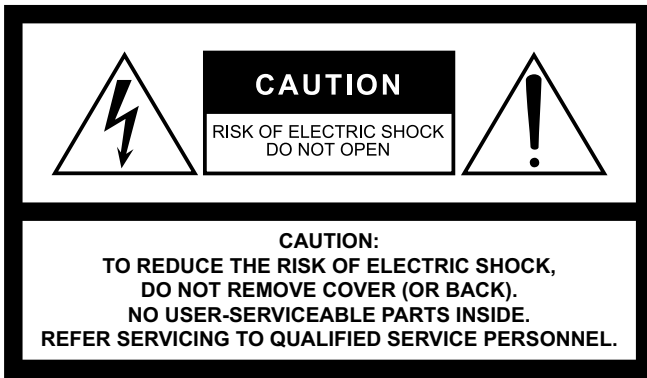

The above warning is located on the rear of the unit.



L'avertissement ci-dessus est situé sur l'arrière de l'unité.

## Explanation of Graphical Symbols Explication des symboles



The lightning flash with arrowhead symbol within an equilateral triangle is intended to alert the user to the presence of uninsulated "dangerous voltage" within the product's enclosure that may be of sufficient magnitude to constitute a risk of electric shock to persons.  
L'éclair avec une flèche à l'intérieur d'un triangle équilatéral est destiné à attirer l'attention de l'utilisateur sur la présence d'une « tension dangereuse » non isolée à l'intérieur de l'appareil, pouvant être suffisamment élevée pour constituer un risque d'électrocution.



The exclamation point within an equilateral triangle is intended to alert the user to the presence of important operating and maintenance (servicing) instructions in the literature accompanying the product.  
Le point d'exclamation à l'intérieur d'un triangle équilatéral est destiné à attirer l'attention de l'utilisateur sur la présence d'instructions importantes sur l'emploi ou la maintenance (réparation) de l'appareil dans la documentation fournie.

## IMPORTANT SAFETY INSTRUCTIONS

- 1 Read these instructions.
- 2 Keep these instructions.
- 3 Heed all warnings.
- 4 Follow all instructions.
- 5 Do not use this apparatus near water.
- 6 Clean only with dry cloth.
- 7 Do not block any ventilation openings. Install in accordance with the manufacturer's instructions.
- 8 Do not install near any heat sources such as radiators, heat registers, stoves, or other apparatus (including amplifiers) that produce heat.
- 9 Do not defeat the safety purpose of the polarized or grounding-type plug. A polarized plug has two blades with one wider than the other. A grounding type plug has two blades and a third grounding prong. The wide blade or the third prong are provided for your safety. If the provided plug does not fit into your outlet, consult an electrician for replacement of the obsolete outlet.
- 10 Protect the power cord from being walked on or pinched particularly at plugs, convenience receptacles, and the point where they exit from the apparatus.
- 11 Only use attachments/accessories specified by the manufacturer.
- 12 Use only with the cart, stand, tripod, bracket, or table specified by the manufacturer, or sold with the apparatus. When a cart is used, use caution when moving the cart/apparatus combination to avoid injury from tip-over.
- 13 Unplug this apparatus during lightning storms or when unused for long periods of time.
- 14 Refer all servicing to qualified service personnel. Servicing is required when the apparatus has been damaged in any way, such as power-supply cord or plug is damaged, liquid has been spilled or objects have fallen into the apparatus, the apparatus has been exposed to rain or moisture, does not operate normally, or has been dropped.



### WARNING

TO REDUCE THE RISK OF FIRE OR ELECTRIC SHOCK, DO NOT EXPOSE THIS APPARATUS TO RAIN OR MOISTURE.

(UL60065\_03)

## PRÉCAUTIONS CONCERNANT LA SÉCURITÉ

- 1 Lire ces instructions.
- 2 Conserver ces instructions.
- 3 Tenir compte de tous les avertissements.
- 4 Suivre toutes les instructions.
- 5 Ne pas utiliser ce produit à proximité d'eau.
- 6 Nettoyer uniquement avec un chiffon propre et sec.
- 7 Ne pas bloquer les orifices de ventilation. Installer l'appareil conformément aux instructions du fabricant.
- 8 Ne pas installer l'appareil à proximité d'une source de chaleur comme un radiateur, une bouche de chaleur, un poêle ou tout autre appareil (y compris un amplificateur) produisant de la chaleur.
- 9 Ne pas modifier le système de sécurité de la fiche polarisée ou de la fiche de terre. Une fiche polarisée dispose de deux broches dont une est plus large que l'autre. Une fiche de terre dispose de deux broches et d'une troisième pour le raccordement à la terre. Cette broche plus large ou cette troisième broche est destinée à assurer la sécurité de l'utilisateur. Si la fiche équipant l'appareil n'est pas compatible avec les prises de courant disponibles, faire remplacer les prises par un électricien.
- 10 Acheminer les cordons d'alimentation de sorte qu'ils ne soient pas piétinés ni coincés, en faisant tout spécialement attention aux fiches, prises de courant et au point de sortie de l'appareil.
- 11 Utiliser exclusivement les fixations et accessoires spécifiés par le fabricant.
- 12 Utiliser exclusivement le chariot, le stand, le trépied, le support ou la table recommandés par le fabricant ou vendus avec cet appareil. Si l'appareil est posé sur un chariot, déplacer le chariot avec précaution pour éviter tout risque de chute et de blessure.
- 13 Débrancher l'appareil en cas d'orage ou lorsqu'il doit rester hors service pendant une période prolongée.
- 14 Confier toute réparation à un personnel qualifié. Faire réparer l'appareil s'il a subi tout dommage, par exemple si la fiche ou le cordon d'alimentation est endommagé, si du liquide a coulé ou des objets sont tombés à l'intérieur de l'appareil, si l'appareil a été exposé à la pluie ou à de l'humidité, si l'appareil ne fonctionne pas normalement ou est tombé.



### AVERTISSEMENT

POUR RÉDUIRE LES RISQUES D'INCENDIE OU DE DÉCHARGE ÉLECTRIQUE, N'EXPOSEZ PAS CET APPAREIL À LA PLUIE OU À L'HUMIDITÉ.

(UL60065\_03)

## FCC INFORMATION (U.S.A.)

### 1. IMPORTANT NOTICE: DO NOT MODIFY THIS UNIT!

This product, when installed as indicated in the instructions contained in this manual, meets FCC requirements. Modifications not expressly approved by Yamaha may void your authority, granted by the FCC, to use the product.

### 2. IMPORTANT:

When connecting this product to accessories and/or another product use only high quality shielded cables. Cable/s supplied with this product MUST be used. Follow all installation instructions. Failure to follow instructions could void your FCC authorization to use this product in the USA.

### 3. NOTE:

This product has been tested and found to comply with the requirements listed in FCC Regulations, Part 15 for Class "B" digital devices. Compliance with these requirements provides a reasonable level of assurance that your use of this product in a residential environment will not result in harmful interference with other electronic devices. This equipment generates/uses radio frequencies and, if not installed and used according to the instructions found in the users manual, may cause interference harmful to the operation of other electronic devices. Compliance with FCC regulations does

not guarantee that interference will not occur in all installations. If this product is found to be the source of interference, which can be determined by turning the unit "OFF" and "ON", please try to eliminate the problem by using one of the following measures:

Relocate either this product or the device that is being affected by the interference.

Utilize power outlets that are on different branch (circuit breaker or fuse) circuits or install AC line filter/s.

In the case of radio or TV interference, relocate/reorient the antenna. If the antenna lead-in is 300 ohm ribbon lead, change the lead-in to co-axial type cable.

If these corrective measures do not produce satisfactory results, please contact the local retailer authorized to distribute this type of product. If you can not locate the appropriate retailer, please contact Yamaha Corporation of America, Electronic Service Division, 6600 Orangethorpe Ave, Buena Park, CA90620

The above statements apply ONLY to those products distributed by Yamaha Corporation of America or its subsidiaries.

\* This applies only to products distributed by Yamaha Corporation of America.

(class B)

### COMPLIANCE INFORMATION STATEMENT (Supplier's declaration of conformity procedure)

Responsible Party : Yamaha Corporation of America  
Address : 6600 Orangethorpe Ave., Buena Park, Calif. 90620  
Telephone : 714-522-9011  
Type of Equipment : PORTABLE PA SYSTEM  
Model Name : STAGEPAS 1K

This device complies with Part 15 of the FCC Rules.

Operation is subject to the following two conditions:

- 1) this device may not cause harmful interference, and
- 2) this device must accept any interference received including interference that may cause undesired operation.

\* This applies only to products distributed by Yamaha Corporation of America.

(FCC SDoC)

# PRECAUTIONS

## PLEASE READ CAREFULLY BEFORE PROCEEDING

Please keep this manual in a safe place for future reference.

This device is designed for use at musical or other live events. Do not use for any purposes other than the one intended. Those who are unfamiliar with handling or those who can not handle according to this manual such as children, should be supervised by responsible persons to ensure safety.



### **WARNING**

**Always follow the basic precautions listed below to avoid the possibility of serious injury or even death from electrical shock, short-circuiting, damages, fire or other hazards. These precautions include, but are not limited to, the following:**

#### **If you notice any abnormality**

- If any of the following problems occur, immediately turn off the power switch and disconnect the electric plug from the outlet.
  - The power cord or plug becomes frayed or damaged.
  - Unusual smells or smoke are emitted.
  - Some object, or water has been dropped into the product.
  - There is a sudden loss of sound during use of the product.
  - Cracks or other visible damage appear on the product.
 Then have the product inspected or repaired by qualified Yamaha service personnel.

#### **Power supply/Power cord**

- Do not place the power cord near heat sources such as heaters or radiators, and do not excessively bend or otherwise damage the cord, place heavy objects on it, or place it in a position where anyone could walk on, trip over, or roll anything over it.
- Only use the voltage specified as correct for the product. The required voltage is printed on the name plate of the product.
- Use only the supplied power cord/plug. If you intend to use the product in an area other than in the one you purchased, the included power cord may not be compatible. Please check with your Yamaha dealer.
- Check the electric plug periodically and remove any dirt or dust which may have accumulated on it.
- Make sure to fully insert the electric plug to prevent electric shocks or fire.
- When setting up the product, make sure that the AC outlet you are using is easily accessible. If some trouble or malfunction occurs, immediately turn off the power switch and disconnect the plug from the outlet. Even when the power switch is turned off, as long as the power cord is not unplugged from the wall AC outlet, the product will not be disconnected from the power source.
- Remove the electric plug from the outlet when the product is not to be used for extended periods of time.
- Do not touch the product or the electric plug during an electrical storm.

- Be sure to connect to an appropriate outlet with a protective grounding connection. Improper grounding can result in electrical shock, fire, or damage.

#### **Do not open**

- This product contains no user-serviceable parts. Do not attempt to disassemble the internal parts or modify them in any way.

#### **Water warning/Fire warning**

- Do not expose the product to rain, use it near water or in damp or wet conditions, or place on it any containers (such as vases, bottles or glasses) containing liquids which might spill into any openings.
- Never insert or remove an electric plug with wet hands.
- Do not place any burning items or open flames near the product, since they may cause a fire.

#### **Hearing loss**

- Before turning the power of all devices on or off, make sure that all volume levels are set to the minimum. Failing to do so may result in hearing loss, electric shock, or device damage.
- When turning on the AC power in your audio system, always turn on the product LAST, to avoid hearing loss and speaker damage. When turning the power off, the product should be turned off FIRST for the same reason.

#### **Wireless unit**

- Do not use this product near medical devices or inside medical facilities. Radio waves from this product may affect electro-medical devices.
- Do not use this product within 15 cm (6 in) of persons with a heart pacemaker implant or a defibrillator implant. Radio waves from this product may affect electro-medical devices, such as a heart pacemaker implant or defibrillator implant.



### **CAUTION**

**Always follow the basic precautions listed below to avoid the possibility of physical injury to you or others. These precautions include, but are not limited to, the following:**

#### **Power supply/Power cord**

- When removing the electric plug from the product or an outlet, always hold the plug itself and not the cord. Pulling by the cord can damage it.

#### **Location and connection**

- Do not place the product in an unstable position or a location with excessive vibration, where it might accidentally fall over and cause injury.
- Keep the device out of reach of children. This product is not suitable for use in locations where children are likely to be present.
- Do not block the vents. This product has ventilation holes at the rear to prevent the internal temperature from becoming too high. In particular, do not place the product on its side or upside down. Inadequate ventilation can result in overheating, possibly causing damage to the product(s), or even fire.

- To ensure proper heat dissipation of the product, when installing it:
  - Do not cover it with any cloth.
  - Make sure the top surface faces up; do not install on its sides or upside down.
  - Do not use the product in a confined, poorly-ventilated location.

Inadequate ventilation can result in overheating, possibly causing damage to the product(s), or even fire. Make sure that there is adequate space around the product: at least 30 cm above, 30 cm at the sides and 30 cm behind.

- Do not carry or transport the device unless it is disassembled. Otherwise, you might be injured if the speaker or spacers strike your head or body.
- Do not place the product in a location where it may come into contact with corrosive gases or salt air. Doing so may result in malfunction.
- Before moving the product, remove all connected cables.
- When transporting or moving the product, always use two or more people. Attempting to lift the product by yourself may damage your back, result in other injury, or cause damage to the product itself.
- Do not press the rear panel of the product against the wall. Doing so may cause the plug to come in contact with the wall and detach from the power cord, resulting in short circuiting, malfunction, or even fire.

## Maintenance

- Remove the power plug from the AC outlet when cleaning the product.

## Handling caution

- Do not insert your fingers or hands in any gaps or openings on the product (vents).
- Do not rest your weight on the product or place heavy objects on it.
- Do not operate the product if the sound is distorting. Prolonged use in this condition could cause overheating and result in fire.



The Bluetooth® word mark and logos are registered trademarks owned by Bluetooth SIG, Inc. and any use of such marks by Yamaha Corporation is under license.

The model number, serial number, power requirements, etc., may be found on or near the name plate, which is at the rear of the unit. You should note this serial number in the space provided below and retain this manual as a permanent record of your purchase to aid identification in the event of theft.

**Model No.**

---

**Serial No.**

---

(rear\_en\_01)

# NOTICE

**To avoid the possibility of malfunction/ damage to the product, damage to data, or damage to other property, follow the notices below.**

## Handling and maintenance

- Do not use the product in the vicinity of a TV, radio, or other electric products. Otherwise, the product, TV, or radio may generate noise.
- Do not expose the product to excessive dust or vibration, or extreme cold or heat, in order to prevent the possibility of panel disfiguration, unstable operation, or damage to the internal components.
- Do not install in locations where temperature changes are severe. Otherwise, condensation may form on the inside or the surface of the product, causing it to break.
- If there is reason to believe that condensation might have occurred, leave the product for several hours without turning on the power until the condensation has completely dried out, in order to prevent possible damage.
- Do not place vinyl, plastic or rubber objects on the product, since this might cause alteration or discoloration of the panel.
- When cleaning the product, use a dry and soft cloth. Do not use paint thinners, solvents, cleaning fluids, or chemical-impregnated wiping cloths, since this might cause alteration or discoloration.

# Information

## About functions/data bundled with the product

- XLR-type connectors are wired as follows (IEC60268 standard): pin 1: ground, pin 2: hot (+), and pin 3: cold (-).

## About this manual

- The illustrations as shown in this manual are for instructional purposes only.
- The company names and product names in this manual are the trademarks or registered trademarks of their respective companies.

## About disposal

- This product contains recyclable components. When disposing of this product, please contact the appropriate local authorities.

Yamaha cannot be held responsible for damage caused by improper use or modifications to the product, or data that is lost or destroyed.

# Table of Contents

---

<b>PRECAUTIONS</b> .....	<b>4</b>	<b>Playing Bluetooth® Audio</b> .....	<b>15</b>
<b>NOTICE</b> .....	<b>5</b>	Registering (pairing) a Bluetooth® device .....	15
<b>Information</b> .....	<b>5</b>	Connecting a Bluetooth® device.....	15
<b>Introduction</b> .....	<b>7</b>	Playing audio files stored in a Bluetooth® device .....	15
Features .....	7	Disconnecting the Bluetooth® device ..	15
Package contents .....	7	<b>Controlling the unit from STAGEPAS Editor</b> .....	<b>16</b>
Optional items .....	7	Connecting STAGEPAS Editor.....	16
About STAGEPAS Editor .....	7	Disconnecting STAGEPAS Editor .....	16
<b>Controls and Functions</b> .....	<b>8</b>	<b>Initializing the STAGEPAS 1K</b> .....	<b>17</b>
Top panel .....	8	<b>Storing the Unit</b> .....	<b>17</b>
Rear panel.....	10	<b>Troubleshooting</b> .....	<b>18</b>
<b>Quick Start Guide</b> .....	<b>12</b>	<b>General Specifications</b> .....	<b>51</b>
Attaching the line array speaker and spacers.....	12	Input Characteristics.....	52
Connecting microphones, musical instruments, or audio devices to the mixer.....	12	Output Characteristics .....	52
Getting sound out of the speaker .....	12	Dimensions.....	53
<b>Combining Two STAGEPAS 1K Units</b> ..	<b>14</b>	<b>Block Diagram</b> .....	<b>54</b>
Playing sound in stereo .....	14		
Expanding the number of STAGEPAS 1K input channels .....	14		

# Introduction

Thank you for purchasing the Yamaha STAGEPAS 1K portable PA System! The STAGEPAS 1K is an all-in-one portable PA system that is designed for use at musical or other live events. This owner's manual is intended for sound crew at live performances or other events. It explains the steps required to set up the STAGEPAS 1K throughout installation and connection of the PA system. It also explains how to operate the STAGEPAS 1K for sound amplification. To get the most out of your STAGEPAS 1K and enjoy its sophisticated range of features, we recommend that you read this manual thoroughly and keep it in a safe place for future reference.

## Features

- Easy setup involves connecting a line array speaker to the subwoofer.
- Line array speaker can consistently cover a broad area.
- 12-inch subwoofer produces a powerful low range.
- Built-in mixer features controls that facilitate complex processes, including “1-knob EQ” that enables you to handle multiple audio processes with only one knob.
- Efficient, dedicated cover that accommodates the line array speaker, spacers, and subwoofer.
- Application software that enables you to control the unit intuitively and in great detail.

## Package contents

- Subwoofer x 1

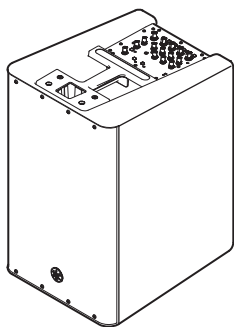

- Dedicated cover x 1

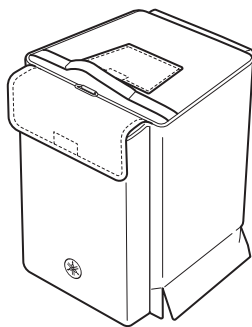

- Line array speaker x 1

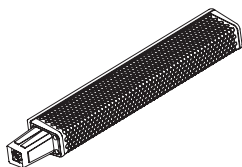

- Spacers x 2

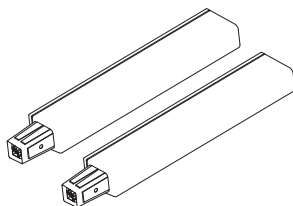

- Power cord x 1

- Owner's Manual (this book)

## Optional items

- DL-SP1K dolly dedicated for STAGEPAS 1K

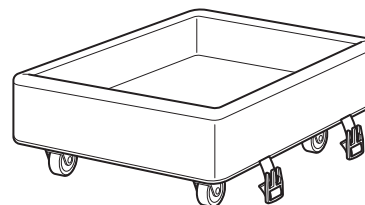

## About STAGEPAS Editor

STAGEPAS Editor is application software that enables you to remotely control the STAGEPAS 1K via Bluetooth from your mobile device, such as a smartphone or tablet. STAGEPAS Editor lets you adjust the parameters and monitor the meters and indicators on the STAGEPAS 1K. It also features music player functions, such as a “Ready Mode” function that engages the unit in stand-by mode until the song starts. This function is very useful when you are busy singing and playing.

For information on how to download STAGEPAS Editor, please refer to the following Yamaha Pro Audio website: <http://www.yamahaproaudio.com/>

# Controls and Functions

## Top panel

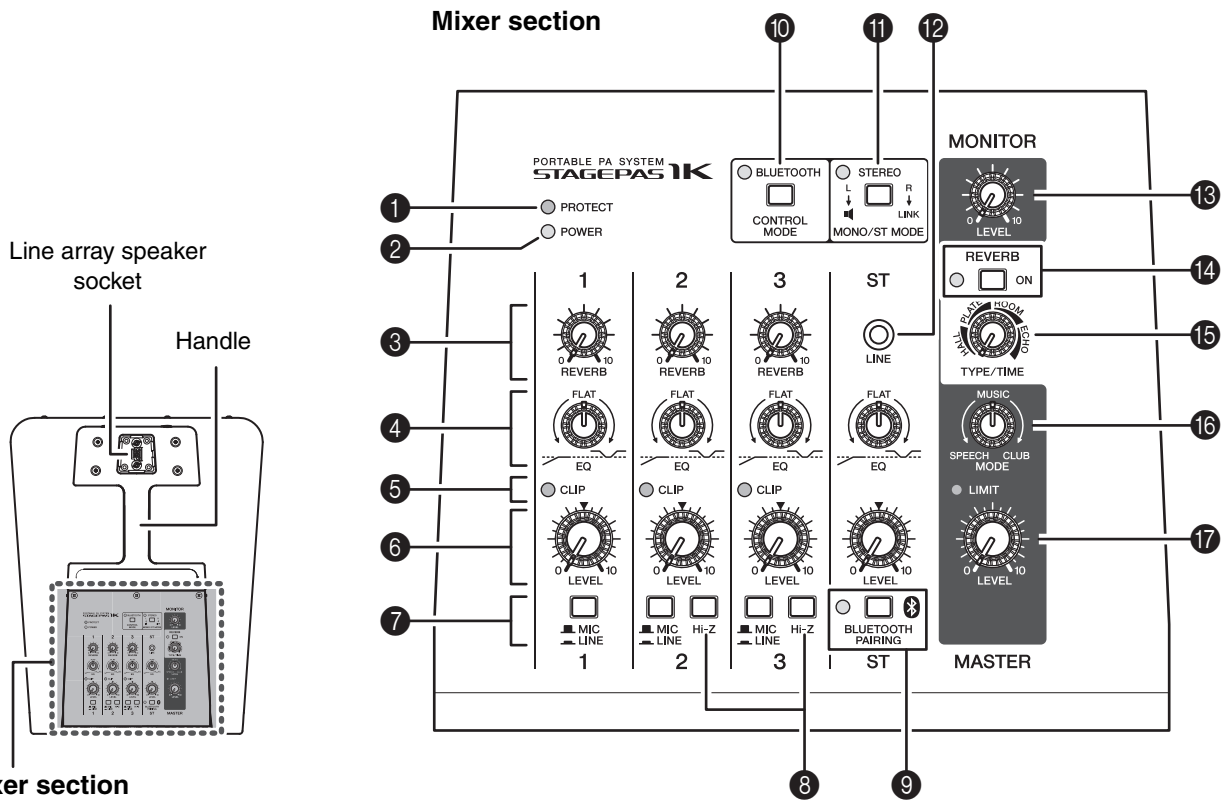

Mixer section

### 1 [PROTECT] LED

Lights red when the protection circuit is activated. The protection circuit will be activated in the following cases, and the speaker output will be muted.

- Amplifier overheat is detected
- A current surge is detected
- The power to the unit is turned on: The protection circuit will be activated for a few seconds to avoid noise. After the unit is properly turned on, the LED will turn off.

If the protection circuit is activated, wait until the temperature of the amplifier section decreases. Alternatively, turn the power to the unit off and then back on. Then the protection circuit will be deactivated. If the protection circuit is not deactivated, please contact your Yamaha dealer.

### 2 [POWER] LED

Lights green when the [I/O] (Power) switch (26) is turned on.

### 3 [REVERB] controls (channels 1-3)

Determine the amount of reverb for each channel when the [REVERB] switch (14) is turned on.

### 4 [EQ] controls

From the center (FLAT) position, turn these controls counterclockwise to cut the low range. Turn them clockwise to boost both low and high ranges.

### 5 [CLIP] LEDs (channels 1-3)

Light red if signals are clipping due to excessive input levels. If these LEDs light up, lower the level of the corresponding input channels, or set the corresponding [MIC/LINE] switches to LINE.

### 6 [LEVEL] controls

Use these controls to adjust the volume for each channel. To reduce noise, set LEVEL controls on unused channels to minimum.

### 7 [MIC/LINE] switches

For low-level signals (including microphones), set the switches to the MIC (M) position. For high-level signals (including electronic musical instruments and audio devices), set the switches to the LINE (L) position.



**8 [Hi-Z] switches (channel 2-3)**

This switch is used when connecting a device directly to the mixer without a DI (direct box)—for example, instruments with passive pickups, such as an acoustic-electric guitar or electric bass without a battery. This function is effective only for the phone jack input.

**9 [BLUETOOTH PAIRING] switch/LED**

This switch turns the Bluetooth audio connection on or off. It is also used to pair (register) a Bluetooth device (page 15).

The LED indicates the following status:

LED	Status
Off	Bluetooth standby mode
Lit steadily	Bluetooth connected
Flashing slowly	Searching for a Bluetooth device
Flashing rapidly	Waiting for Bluetooth pairing

**NOTE**

The STAGEPAS 1K enables you to pair (register) up to eight Bluetooth devices. Once the ninth Bluetooth device has been paired successfully, the pairing information for the Bluetooth device that was connected earliest will be deleted.

**10 [BLUETOOTH/CONTROL MODE] switch/LED**

This switch determines whether or not you can control the unit from STAGEPAS Editor.

The LED indicates the following status:

LED	Status
Off	Control disabled
Lit steadily	Connected to STAGEPAS Editor
Flashing slowly	Waiting for connection to STAGEPAS Editor

**11 [MONO/ST MODE] switch/LED**

Enables you to select whether the audio output from the speaker is monaural (MONO) or stereo (STEREO). Pressing this switch repeatedly will toggle between MONO and STEREO. If STEREO is selected, the L-channel signal of the stereo input will be output from this unit, while the R-channel signal will be output via the [LINK] output jack to the other STAGEPAS 1K.

The LED will light orange if STEREO is selected.

**12 [LINE] input jack**

Supports stereo-mini plugs. Connect an audio device here. A signal from the Bluetooth device is always mixed to the ST IN channel.

**13 [MONITOR] control**

Determines the signal level output from the [MONITOR] output jack (23). The [MASTER LEVEL] control does not affect this signal.

**14 [REVERB] switch/ LED**

When this switch is on, the LED lights up, indicating that you can apply reverb (reverberation/echo).

**15 [REVERB TYPE/TIME] control**

Determines reverb type and length. Turning the control clockwise lengthens the time of the selected reverb type.

**HALL:** Simulated reverb of a large space, such as a concert hall.

**PLATE:** Simulated steel plate reverb, producing a harder-edged and brighter sound.

**ROOM:** Simulated acoustic ambience of a small room.

**ECHO:** Echo effect suitable for vocals.

**16 [MODE] control**

Use this control to adjust the overall sound pressure and frequency balance. The center position (MUSIC) is a basic setting. If you turn the control counterclockwise (SPEECH), it will cut unneeded low-range frequencies, and create an optimum setting for speech, or singing and playing an acoustic musical instrument. If you turn the control clockwise (CLUB), it will create an optimum setting for playback of sound sources, since the high and low ranges are boosted.

**17 [MASTER LEVEL] control**

Determines the volume level of the signal output from the speaker and the level of the signal routed to the [LINK] output jack simultaneously. This allows you to adjust the overall volume without changing the relative volume balance among the various channels. The [LIMIT] LED lights when the limiter is applied.

## Rear panel

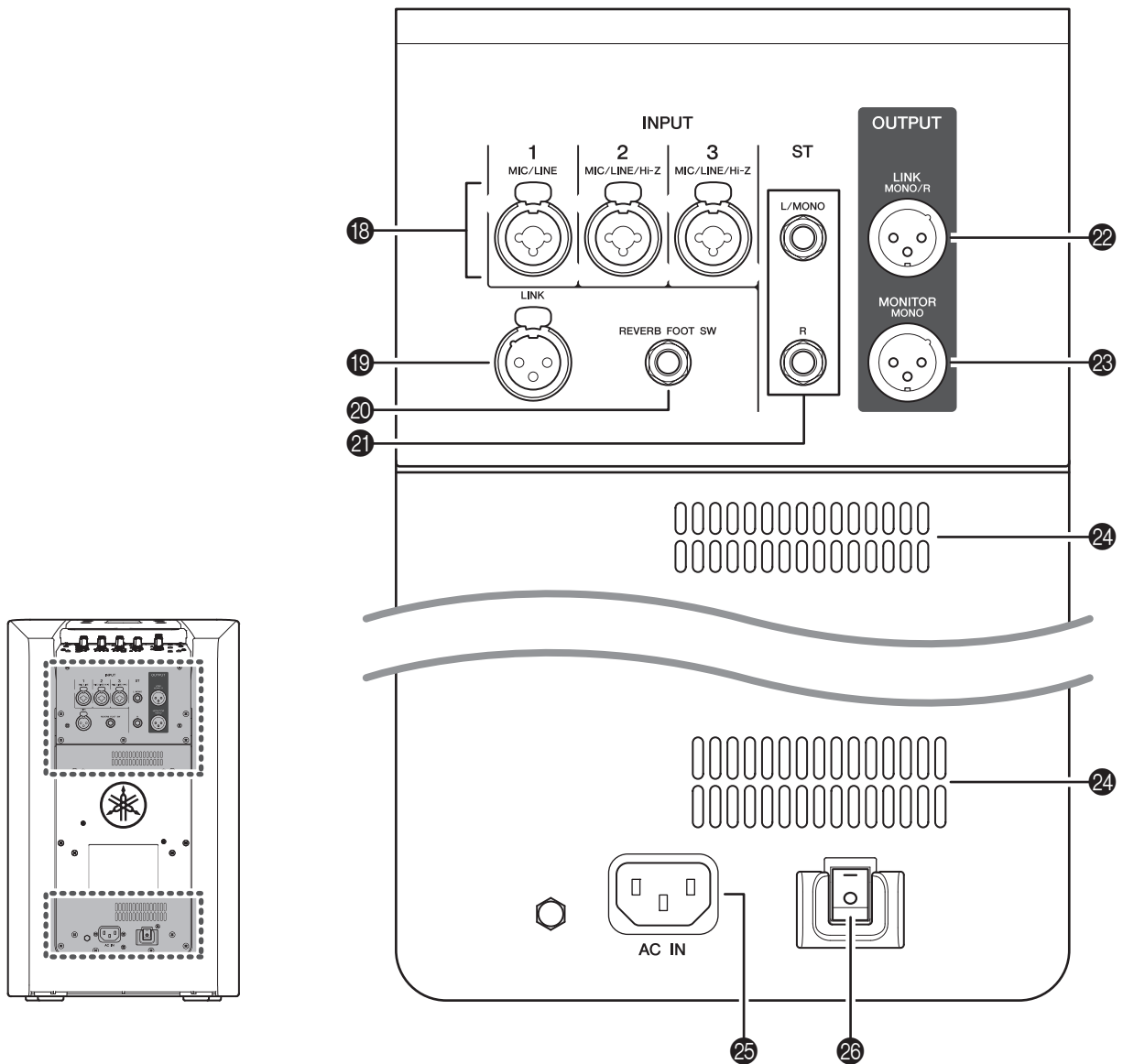

### 18 Mic/Line input jacks (channels 1-3)

Connect microphones, guitars, electronic musical instruments or audio equipment. These are combo jacks that support both XLR and phone plugs. Channels 2 and 3 support Hi-Z.



XLR

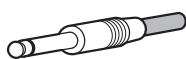

Phone

### 19 [LINK] input jack

This jack supports an XLR-type plug. If you use two STAGEPAS 1K units, connect the [LINK] output jack of the first unit to the [LINK] input jack of the second unit (See page 14 “Playing sound in stereo”).

We recommend that you use this jack if you plan to input a line-level signal from an external mixing console.

**20 [REVERB FOOT SW] jack**

This connects to an unlatched-type footswitch, such as the Yamaha FC5. This can be useful for solo performers, since you can toggle the reverb on and off as needed with your foot.

**21 [ST] input jacks**

These jacks support phone-type plugs. Connect line-level devices such as electronic musical instruments, acoustic-electric guitars, CD players, and portable audio players.

For monaural input, connect a cable to the L/MONO jack. For stereo input, connect cables to both L/MONO and R jacks. A signal from the Bluetooth device is always mixed to the ST IN channel.

**22 [LINK] output jack**

This jack supports an XLR-type plug. Mixed signals are output to the other STAGEPAS 1K. Connect the [LINK] output jack of the first STAGEPAS 1K to the [LINK] output jack of the other STAGEPAS 1K.

Alternatively, you can connect a powered speaker here. (See page 9 **11** [MONO/ST MODE] switch/LED).

**23 [MONITOR] output jack**

This jack supports an XLR-type plug. You can connect a powered speaker to this jack for monitoring purposes. Mixed monaural signals are output from here. Use the MONITOR control to adjust the output level (**13**). This jack is useful when you are recording a live performance to a recorder, or distributing a live broadcast.

**24 Vents**

These are the vents for the cooling fan inside the mixer. Do not block the vents when the unit is in use.

**25 [AC IN] jack**

Connect the included power cord here. Connect the power cord to this jack, and then insert the power plug into an AC outlet.

Be sure to turn off the power switch before connecting or disconnecting the power cord.

**26 I / O (Power) switch**

Turns the power to the unit on (I) or off (O). When you turn on the power to all connected devices, be sure to first turn on the power to the external sound source, then to this unit, and finally to the device that is connected to the [MONITOR] output jack or [LINK] output jack. When you turn off the power to all devices, follow this order in reverse.

**Notice**

Even when the power switch is turned off, a minimal amount of electric current is still flowing to the unit. If you plan not to use the unit for an extended period of time, be sure to unplug the power cord from the AC outlet.

**NOTE**

Rapidly turning the unit on and off in succession may cause it to malfunction. After turning the unit off, wait for about five seconds before turning it on again.

# Quick Start Guide

## Attaching the line array speaker and spacers

Use the included spacers to install the line array speaker at approximately the same height as the ears of the audience. The line array speaker features a grille.

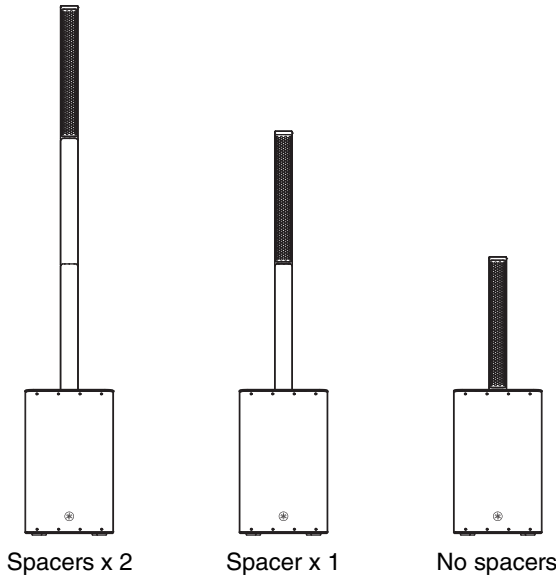

1. Insert the line array speaker and spacers firmly into the sockets one by one.

Use the spacers as needed.

**NOTE**

Insert the line array speaker and spacers firmly into the sockets. If the connectors are not in contact sufficiently, no sound may be output.



## Connecting microphones, musical instruments, or audio devices to the mixer

Before making connections, lower the volume level to the minimum by rotating the [LEVEL] controls counter-clockwise.

■ Connection example

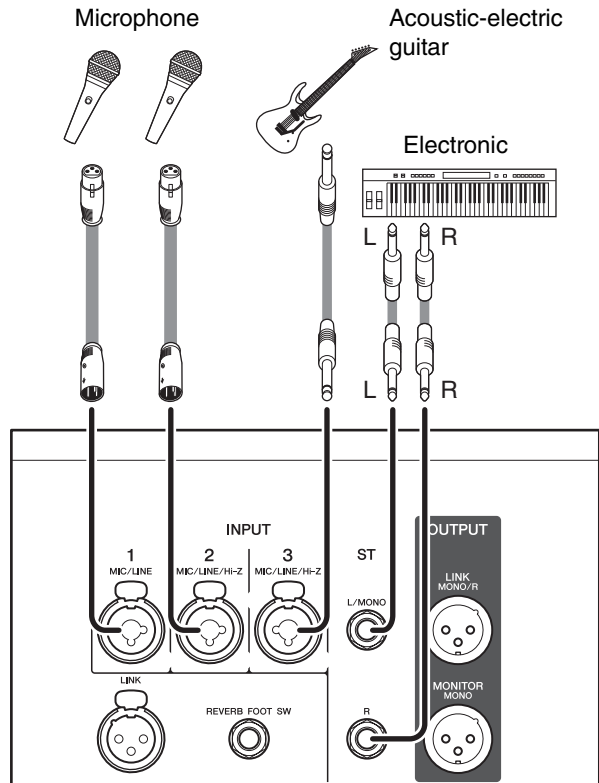

2. Connect desired devices, such as a microphone, or a musical instrument to the input jacks of the mixer.

## Getting sound out of the speaker

Make sure that the power to the STAGEPAS 1K is turned off.

3. Connect the plug on the included power cord to the [AC IN] jack on the rear panel of the unit.

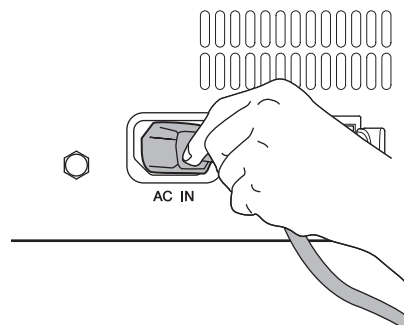

4. Insert the other end of the power cord into a power outlet.



### Warning

- The STAGEPAS 1K has been designed for grounded use. To avoid electrical shock and damage to connected devices, be sure to ground the unit using the included power cord. If you have any questions regarding proper connections, please contact your nearest Yamaha dealer.
- Use only the included power cord. Otherwise, heat may be generated or an electrical shock may be caused.

### Notice

Even when the power switch is turned off, a minimal amount of electric current is still flowing to the unit. If you plan not to use the unit for an extended period of time, be sure to unplug the power cord from the AC outlet.

5. Turn the [LEVEL] controls (white knobs) and [MASTER LEVEL] control (red knob) to the minimum (zero).

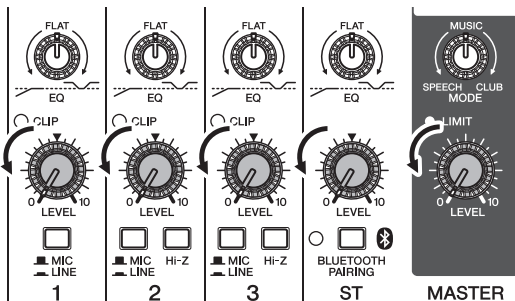

6. Also, set the [EQ] controls (green knobs) to the center (FLAT) position, and set the [MODE] control (yellow knob) to the (MUSIC) position.

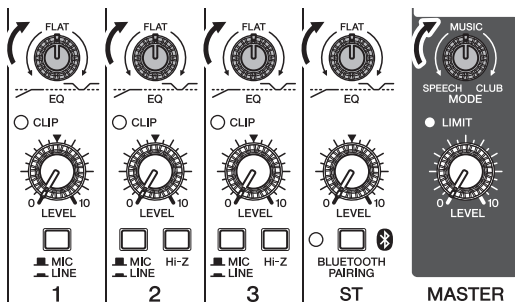

7. Set the [MIC/LINE] switch to the MIC (■) position for channels to which a microphone is connected. Set the [MIC/LINE] switch to the LINE (▬) position for channels to which a musical instrument or audio device is connected.

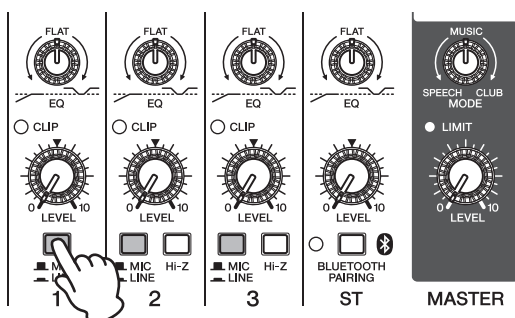

8. Turn on the power to the connected musical instrument or audio device, then to this unit.

The [POWER] LED lights up.



9. Use the [MASTER LEVEL] control to adjust the volume to an appropriate level.

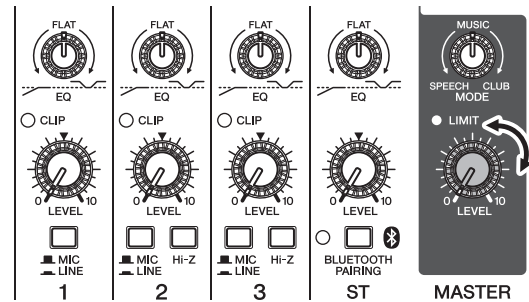

10. While playing your musical instrument or singing into the microphone, use the [LEVEL] controls to adjust the volume of the corresponding channels.

11. Use the [MASTER LEVEL] control to adjust the overall volume.

If you can hear sound and the volume seems appropriate, setup is complete. If not, please refer to the checklist in the "Troubleshooting" section (page 18).

### NOTE

To avoid any loud, unexpected noises from the speaker, first turn off the power to this unit, and then turn off the connected sound source (such as a musical instrument or audio device).

### Adjusting the volume

#### ■ When the volume is too loud

Turn the [LEVEL] control for the corresponding channel to the minimum (zero). Set the [MIC/LINE] switch to the LINE (▬) position, then slowly raise the [LEVEL] control until the desired volume is reached.

#### ■ When the volume is too low

Turn the [LEVEL] control for the corresponding channel to the minimum (zero). Set the [MIC/LINE] switch to the MIC (■) position, then slowly raise the [LEVEL] control until the desired volume is reached.

# Combining Two STAGEPAS 1K Units

## Playing sound in stereo

You can use two STAGEPAS 1K units to play sound in stereo.

1. Connect the [LINK] output jack of the L-channel STAGEPAS 1K to the [LINK] input jack of the R-channel STAGEPAS 1K.

Use the L-channel STAGEPAS 1K to input an audio signal from the source.

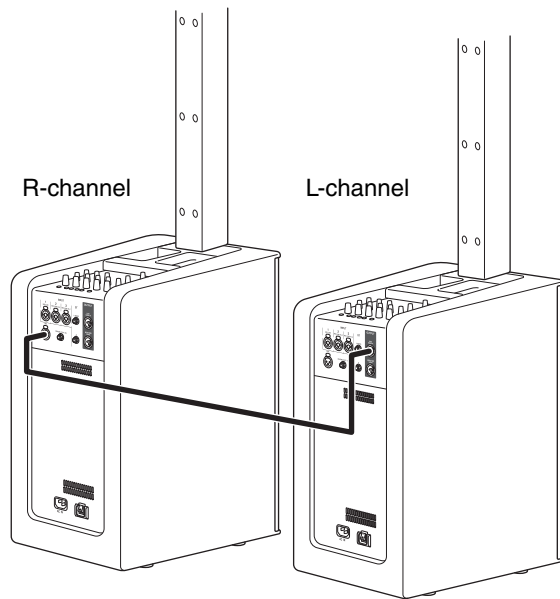

### NOTE

A signal input to the R-channel STAGEPAS 1K (on channels 1–3 or ST) will be played only from the R-channel speaker.

2. Press the [MONO/ST MODE] switch to engage STEREO mode.

The [STEREO] LED lights in STEREO mode.

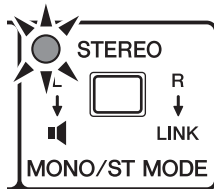

## Expanding the number of STAGEPAS 1K input channels

You can double the number of input channels by connecting two STAGEPAS 1K to each other. Each STAGEPAS 1K will operate as monaural.

1. Connect the [LINK] input jack and the [LINK] output jack of one of the STAGEPAS 1K units to the [LINK] output jack and [LINK] input jack of the other unit.

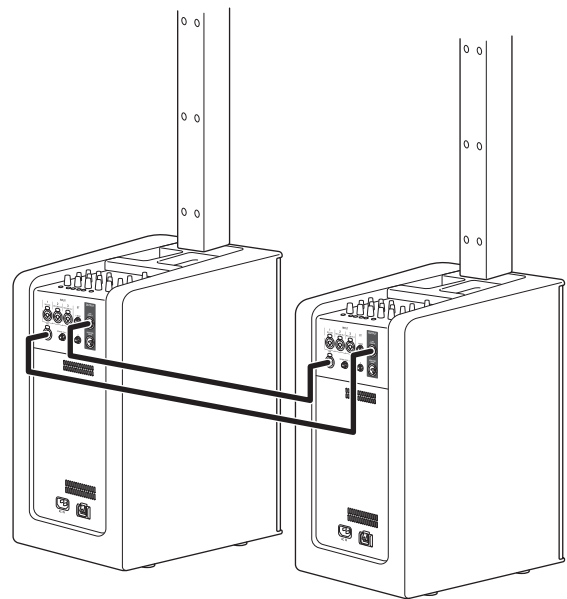

2. Press the [MONO/ST MODE] switch to engage MONO mode on both units.

The [STEREO] LED turns off in MONO mode.

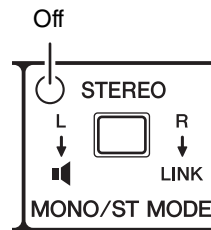

STAGEPAS 1K  
(1st unit)

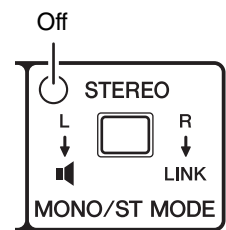

STAGEPAS 1K  
(2nd unit)

# Playing Bluetooth® Audio

You can set up the STAGEPAS 1K so it will play audio files stored in Bluetooth devices, such as a mobile device.

## Registering (pairing) a Bluetooth® device

Before you can connect a Bluetooth device for the first time, you need to “pair” the device. “Pairing” refers to registering one Bluetooth device with another Bluetooth device.

Once pairing is complete, you will be able to reconnect those devices easily after you terminate a Bluetooth connection.

1. **Make sure that the [BLUETOOTH PAIRING] LED is turned off. If the LED is lit steadily or is flashing, press the [BLUETOOTH PAIRING] switch to place the Bluetooth function in standby mode.**
2. **Press and hold down the [BLUETOOTH PAIRING] switch for three seconds or longer.**

The [BLUETOOTH PAIRING] LED will flash rapidly, indicating that the unit is ready for pairing.



3. **Turn on the Bluetooth function on the Bluetooth device that you want to pair.**  
For more information, refer to the owner’s manual for the Bluetooth device.
4. **Once the Bluetooth device displays a list of other Bluetooth devices that are available for connection, select STAGEPAS 1K AUDIO.**

### NOTE

You can change the name of the unit in the Device Name setting of STAGEPAS Editor.

When the pairing process is complete, the Bluetooth connection will be established and the [BLUETOOTH PAIRING] LED will light up.



### NOTE

- The STAGEPAS 1K enables you to pair (register) up to eight Bluetooth devices. Once the ninth Bluetooth device has been paired successfully, the pairing information for the Bluetooth device that was connected earliest will be deleted.
- You must complete the pairing process on the Bluetooth device within two minutes.

## Connecting a Bluetooth® device

1. **Press and hold down the [BLUETOOTH PAIRING] switch for one second.**  
The [BLUETOOTH PAIRING] LED will flash slowly, indicating that the unit is searching for a device.
2. **Turn on the Bluetooth function on the Bluetooth device that you want to connect.**  
When the connection is made automatically, the [BLUETOOTH PAIRING] LED will light up.

### NOTE

Even if the STAGEPAS 1K is in Bluetooth standby mode (the [BLUETOOTH PAIRING] LED is off), you can still connect your Bluetooth device by following the steps below:

1. **Turn on the Bluetooth function on the Bluetooth device that you want to connect.**
2. **Select STAGEPAS 1K AUDIO from the list of Bluetooth devices displayed on your Bluetooth device.**

## Playing audio files stored in a Bluetooth® device

You can use the STAGEPAS 1K to listen to an audio file playing on your Bluetooth device.

Signals from the Bluetooth device are input to the ST channel.

We recommend that you set the volume on the Bluetooth device a little higher than normal, and then adjust the volume for each channel using the ST [LEVEL] control.

If you receive a call or text message while playing audio files on your Bluetooth device such as a smartphone, audio file playback might be paused momentarily. To avoid this interruption, enable Airplane Mode, and then set Bluetooth to ON on your Bluetooth device.

## Disconnecting the Bluetooth® device

To disconnect the Bluetooth device, do one of the following:

- Use the Bluetooth device to disconnect. (The [BLUETOOTH PAIRING] LED on the unit will flash slowly, indicating that the unit now enters connection search mode.)
- Press the [BLUETOOTH PAIRING] switch on the unit to engage Bluetooth standby mode (The [BLUETOOTH PAIRING] LED will turn off.)

### Notice

Before you turn off the power to the unit, make sure that the Bluetooth function is turned off. (Make sure that the [BLUETOOTH PAIRING] LED is turned off.) If you turn off the power to the unit while the Bluetooth function remains enabled, the unit might lose the pairing information.

# Controlling the unit from STAGEPAS Editor

You can control the parameters and view the meters and clipping information of the STAGEPAS 1K from your Bluetooth device, such as a mobile device.

To view information on how to use STAGEPAS Editor, tap the [Manual] button on SETTINGS screen in STAGEPAS Editor.

## Connecting STAGEPAS Editor

To control the STAGEPAS 1K in this way, you first need to connect a device on which STAGEPAS Editor has been installed. (Alternatively, you can control the unit from a device that is different than the one connected for Bluetooth audio.)

1. **Press and hold down the [BLUETOOTH/CONTROL MODE] switch for one second.**

The [BLUETOOTH/CONTROL MODE] LED will flash slowly, indicating that the unit is ready for connection.

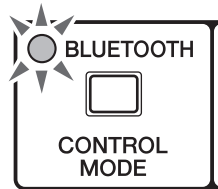

2. **Start STAGEPAS Editor.**
3. **On the Device List screen, tap the name of the STAGEPAS unit that you want to control from STAGEPAS Editor.**

The name of the target STAGEPAS unit will be highlighted.

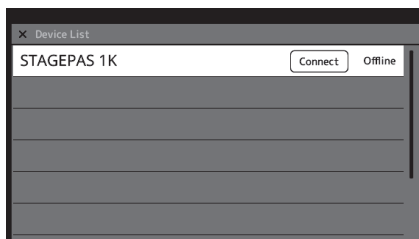

4. **Tap “Connect.”**

When the connection is complete, the Bluetooth connection will be established and the [BLUETOOTH/CONTROL MODE] LED will light up.

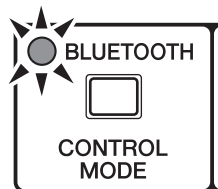

### NOTE

When you reconnect your Bluetooth device, you do not need to follow steps 3 and 4 above.

## Disconnecting STAGEPAS Editor

### ■ Disconnecting from the unit

1. **Press and hold down the [BLUETOOTH/CONTROL MODE] switch for three seconds or longer.**

The [BLUETOOTH/CONTROL MODE] LED will turn off, indicating that the control is disabled.

### NOTE

- The mixer parameters will restore the values set by the control knobs on the unit.
- Parameters that can be controlled from STAGEPAS Editor will be initialized to the default values.

### ■ Disconnecting from STAGEPAS Editor

1. **Open the Device List screen in STAGEPAS Editor.**

The name of the target STAGEPAS unit will be highlighted.

2. **Tap “Disconnect.”**

The [BLUETOOTH/CONTROL MODE] LED will flash, indicating that STAGEPAS Editor is ready for connection. STAGEPAS 1K will maintain the mixer parameter values that were set in the application.



# Initializing the STAGEPAS 1K

If you want to reset the parameters that were programmed from STAGEPAS Editor, or reset the Bluetooth pairing (registering) information to the factory default settings, follow the steps below:

1. Turn the power switch off.
2. While pressing and holding down the [BLUETOOTH/CONTROL MODE] switch and [REVERB] switch simultaneously, turn on the I/O (Power) switch on the rear panel.

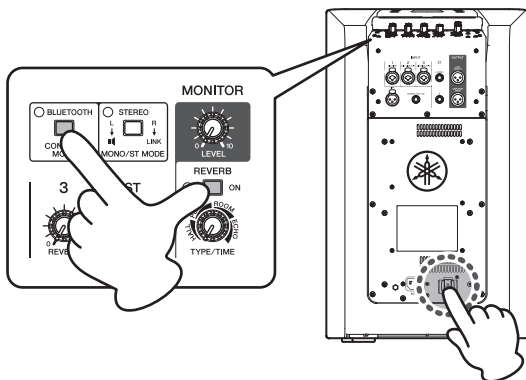

While the unit is being initialized, the [POWER] LED, [BLUETOOTH/CONTROL MODE] LED, and [BLUETOOTH PAIRING] LED will flash.

3. When the initialization is complete, the unit automatically restarts.

After the initialization process, the parameter values will change as follows:

Parameter	Value
REVERB	Knob position
EQ	
REVERB TYPE/TIME	
MODE	
MONITOR LEVEL	
MASTER LEVEL	
REVERB ON/OFF	Default (OFF)
STEREO MONO/ST MODE	Default (MONO)
BLUETOOTH CONTROL MODE	Default (OFF)
Bluetooth audio pairing (registration) information	All cleared
CHANNEL LEVEL*	Default (0 dB)
CHANNEL ON*	Default (ON)
PAN*	Default (CENTER)
CHANNEL REVERB LEVEL*	Default (ON)
REVERB LEVEL*	Default (-3 dB)
MASTER ON/OFF*	Default (ON)
LABEL*	Default (STAGEPAS 1K)
PRESET*	Values for PRESET #1-8 are cleared.
PASSCODE*	Disabled

\* Parameters that can be controlled only from STAGEPAS Editor

# Storing the Unit

1. Install the included, dedicated cover over the STAGEPAS 1K.

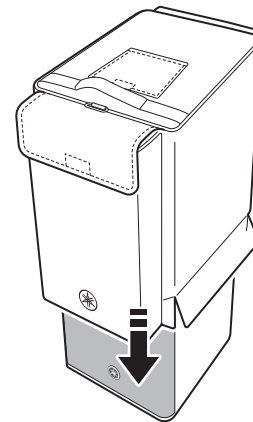

2. Put the line array speaker and spacers into the pocket that is marked with the Yamaha logo.

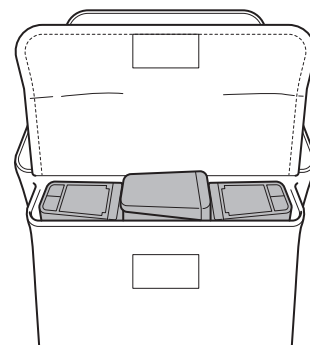

To move the unit, open the flap on top of the cover and hold the handle on the unit.

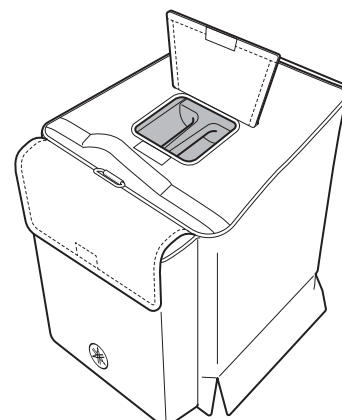

## NOTE

For information regarding the DL-SP1K, an optional dolly designed for use with the unit, please refer to the DL-SP1K Owner's Manual.

# Troubleshooting

---

## Power does not turn on.

- Did you firmly and securely connect the power cord?

## Power shuts down suddenly.

- Are the vents of the mixer blocked?  
Since inadequate ventilation can result in overheating the mixer, the power may be turned off automatically to protect the system from overheating. Arrange the ventilation for better cooling, then turn on the power again.

## No sound is heard.

- Did you insert the line array speaker and spacers firmly into the sockets?  
If the speaker is not inserted into the spacers or socket firmly, the connectors will not make sufficient contact and no sound will be output.
- Is the [PROTECT] LED lit?  
If the internal power amplifier section is overloaded, the amplifier will be muted to protect its circuits. The mixer will automatically reset itself after a while.

## Sound is distorted or noise is produced

- Are the [LEVEL] controls of any relevant channels and/or the [MASTER LEVEL] control set too high?
- Is the [MIC/LINE] switch of the corresponding channel set to MIC?  
If the input level from the source is high, setting the [MIC/LINE] switch to MIC may result in a distorted sound. Set the switch to LINE.
- Is the volume of the connected device too high?  
Lower the volume of the external device.

## Sound is not loud enough

- Are the [LEVEL] controls of all relevant channels and/or the [MASTER LEVEL] control set too low?
- Is the [MIC/LINE] switch of the corresponding channel set to LINE?  
Turn the [LEVEL] control to the minimum (zero). Set the switch to MIC, then slowly raise the [LEVEL] control.
- Is the volume of the connected device too low?  
Raise the volume of the external device.
- Some settings can be controlled only from STAGEPAS Editor.  
Use STAGEPAS Editor to adjust the settings.

## The high-range sounds and low-range sounds are unbalanced.

- Are the [EQ] controls raised or lowered too much?  
Set the [EQ] controls to the center position.
- Is the speaker properly outputting high-frequency range signals?  
If not, make sure that the line array speaker is firmly inserted into the socket.

## Cannot connect Bluetooth

- The unit may be connected to a different Bluetooth device.  
Cut the current Bluetooth connection, and then connect to the desired Bluetooth device.  
You can use one Bluetooth devices to control the STAGEPAS 1K, and a second Bluetooth device to play Bluetooth audio remotely.
- Your Bluetooth device may not support the A2DP profile.  
Use a Bluetooth device that supports A2DP.

## Bluetooth audio sound cuts intermittently

- The unit may be located in the vicinity of a device that emits electro-magnetic waves at a frequency of 2.4GHz (such as a wireless microphone transmitter, wireless LAN device, microwave oven, etc.).  
Locate the STAGEPAS 1K away from any device that emits electro-magnetic waves.  
If your Bluetooth device also features a wireless LAN function, turn off the function, and use only the Bluetooth function.

If a problem persists, please contact your Yamaha dealer.

# General Specifications

## ■ Main specifications

<b>System Type</b>	Powered subwoofer with a line array speaker
<b>Frequency Response (-10 dB)</b>	37 Hz - 20 kHz
<b>Coverage Angle (Horizontal x Vertical)</b>	170° x 30°
<b>Crossover Frequency</b>	240 Hz
<b>Maximum Output Level (Measured peak, IEC noise@1m)</b>	119 dB SPL
<b>Power Requirements</b>	110-120V 60Hz, 220-240V 50/60Hz
<b>Power Consumption</b>	25W (idle), 85W (1/8 power)
<b>Dimensions (W x H x D)</b>	System (maximum) 334 x 2,000 x 415 mm
<b>Weight</b>	23.0 kg

## ■ Mixer section

<b>The number of Mixing Channels</b>	5
<b>Analog Inputs</b>	Mono mic/line x 3, mono line x 2, stereo line x 1 LINK IN (MONO)
<b>Bluetooth Audio Inputs</b>	A2DP (SBC, AAC)
Content Protection Method	SCMS-T
Bluetooth Version	Ver 5.0
Transmission Frequencies	2,402 - 2,480 MHz
Wireless Output	Class 1
Maximum Wireless Output Power (EIRP)	15 dBm (32 mW)
<b>Channel Functions</b>	Hi-Z switch: CH2/3
<b>EQ/Effects</b>	1-knob EQ: CH1/2/3, L/MONO, R, ST LINE MODE (SPEECH/MUSIC/CLUB) 4 types of reverb (HALL/PLATE/ROOM/ECHO): CH1/2/3
<b>Outputs</b>	LINK OUT (MONO/R) MONITOR OUT (MONO)
<b>External Controls</b>	Reverb foot switch STAGEPAS Editor (iOS/Android app)

## ■ Amplifier section

<b>Rated Output</b>	Dynamic	1000W (Subwoofer: 810W, Line array speaker: 190W)
---------------------	---------	---

## ■ Speaker section

<b>Enclosure</b>	Line array speaker : Enclosed Subwoofer : Bass-reflex type
<b>Speaker Unit</b>	Line array speaker : 1.5" (3.8 cm) Cone x 10 Subwoofer : 12" (30 cm) Cone
<b>Dimensions (W x H x D)</b>	Line array speaker : 67 x 582 x 86 mm Spacer (each) : 67 x 555 x 86 mm Subwoofer : 334 x 550 x 418 mm
<b>Weight:</b>	Line array speaker : 1.8 kg Spacer (each) : 0.6 kg Subwoofer : 20.0 kg

## ■ Accessories

<b>Included in the package</b>	Power cord x 1, Dedicated cover x 1, Owner's Manual
<b>Optional accessories</b>	DL-SP1K (dedicated dolly)

## Input Characteristics

Input Terminals	Connector Type		Hi-Z SW	MIC/LINE SW	Input Impedance	Source Impedance	Input Level* <sup>1</sup>			
							Sensitivity* <sup>2</sup>	Nominal* <sup>3</sup>	Max. before Clipping	
CH IN1	XLR Combo	XLR	–	MIC	3 kΩ (Balance)	150Ω Mics/Lines	–50 dBu	–36 dBu	–10 dBu	
			–	LINE			–24 dBu	–10 dBu	+16 dBu	
		Phone	–	MIC	10 kΩ (Balance)	150Ω Mics/Lines	–44 dBu	–30 dBu	–4 dBu	
			–	LINE			–18 dBu	–4 dBu	+22 dBu	
CH IN2-3	XLR Combo	XLR	–	MIC	3 kΩ (Balance)	150Ω Mics/Lines	–50 dBu	–36 dBu	–10 dBu	
			–	LINE			–24 dBu	–10 dBu	+16 dBu	
		Phone	OFF	–	MIC	10 kΩ (Balance)	150Ω Mics/Lines	–44 dBu	–30 dBu	–4 dBu
				–	LINE			–18 dBu	–4 dBu	+22 dBu
			ON	–	MIC	1 MΩ (Unbalance)	10 kΩ Lines	–44 dBu	–30 dBu	–4 dBu
				–	LINE			–18 dBu	–4 dBu	+22 dBu
ST IN	Phone (TS)* <sup>4</sup>		–	–	10 kΩ (Unbalance)	150Ω Lines	–18 dBu	–4 dBu	+22 dBu	
	STEREO mini		–	–	10 kΩ (Unbalance)	150Ω Lines	–18 dBu	–4 dBu	+22 dBu	
LINK IN	XLR-3-31		–	–	20 kΩ (Balance)	150Ω Lines	+10 dBu	–	+24 dBu	

\*1. 0 dBu= 0.775 Vrms

\*2. INPUT VOLUME= MAX

\*3. INPUT VOLUME= Nominal (Center position)

\*4. Phone: Unbalanced

## Output Characteristics

Output Terminals	Output Impedance	Load Impedance	Output Level		Connector Type
			Nominal	Max. before Clipping	
LINK OUT [MONO/R]	75Ω	10 kΩ Lines	+10 dBu	+24 dBu	XLR-3-32
MONITOR OUT [MONO]	75Ω	3 kΩ Lines	+10 dBu	+24 dBu	XLR-3-32

\* 0 dBu=0.775 Vrms

\* The contents of this manual apply to the latest specifications as of the publishing date. To obtain the latest manual, access the Yamaha website then download the manual file.

\* Le contenu de ce mode d'emploi s'applique aux dernières caractéristiques techniques connues à la date de publication du manuel. Pour obtenir la version la plus récente du manuel, accédez au site Web de Yamaha puis téléchargez le fichier du manuel concerné.

\* El contenido de este manual se aplica a las últimas especificaciones según la fecha de publicación. Para obtener el último manual, acceda al sitio web de Yamaha y descargue el archivo del manual.

## Dimensions

### ■ Subwoofer

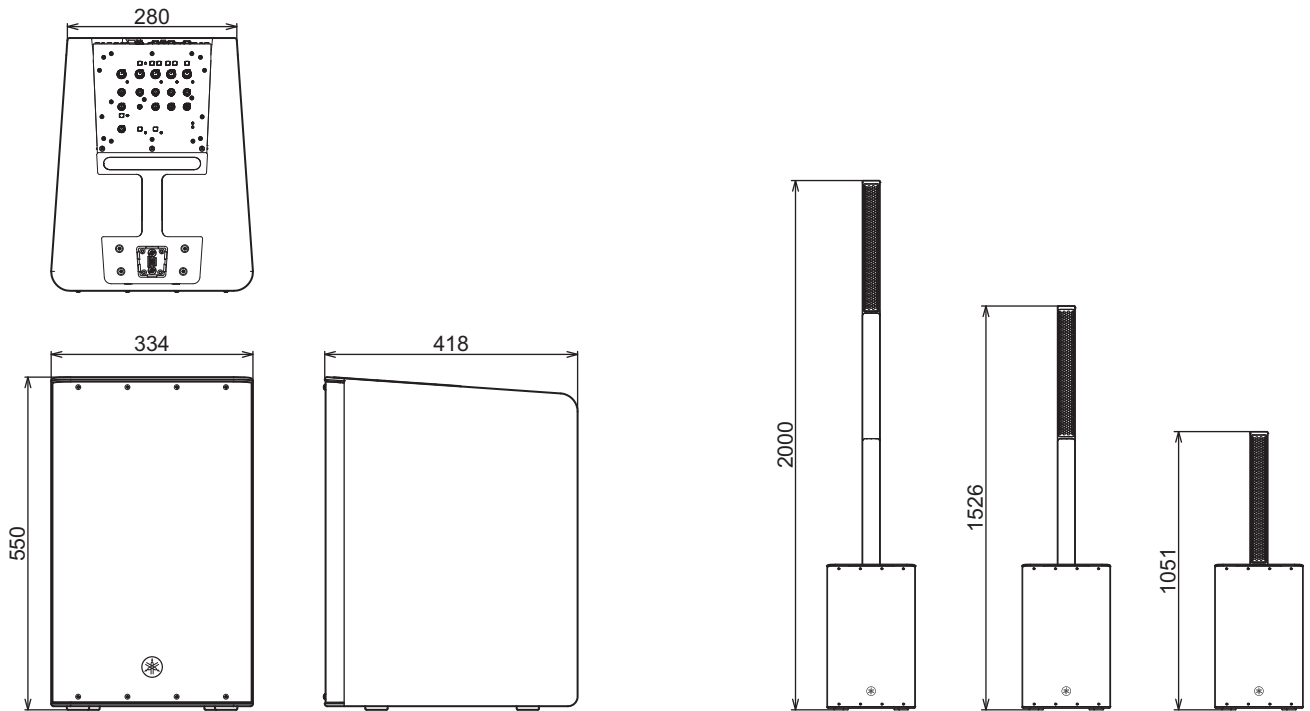

### ■ Line array speaker

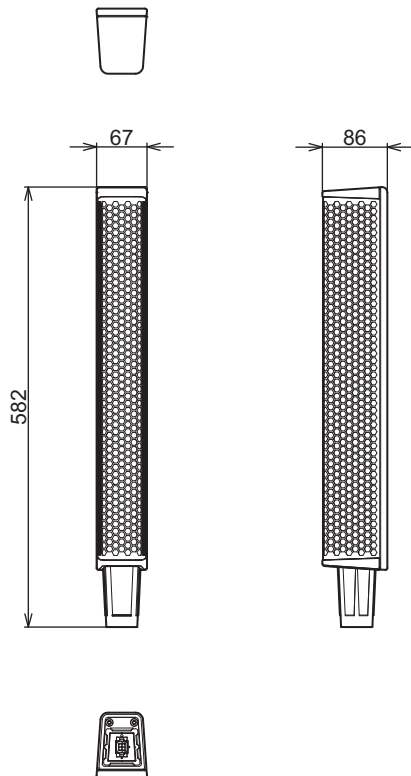

### ■ Spacer

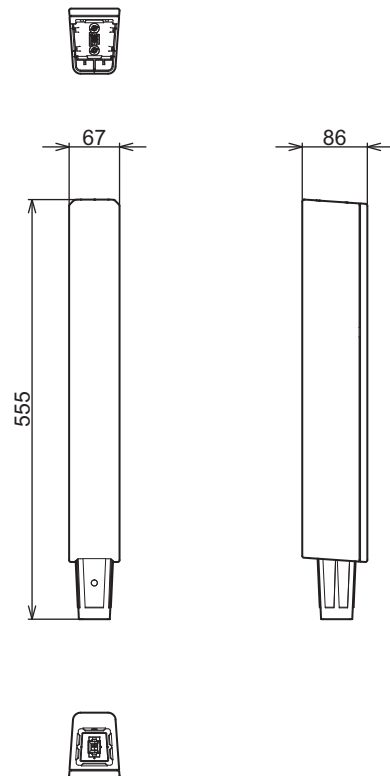

Unit: mm

# Block Diagram

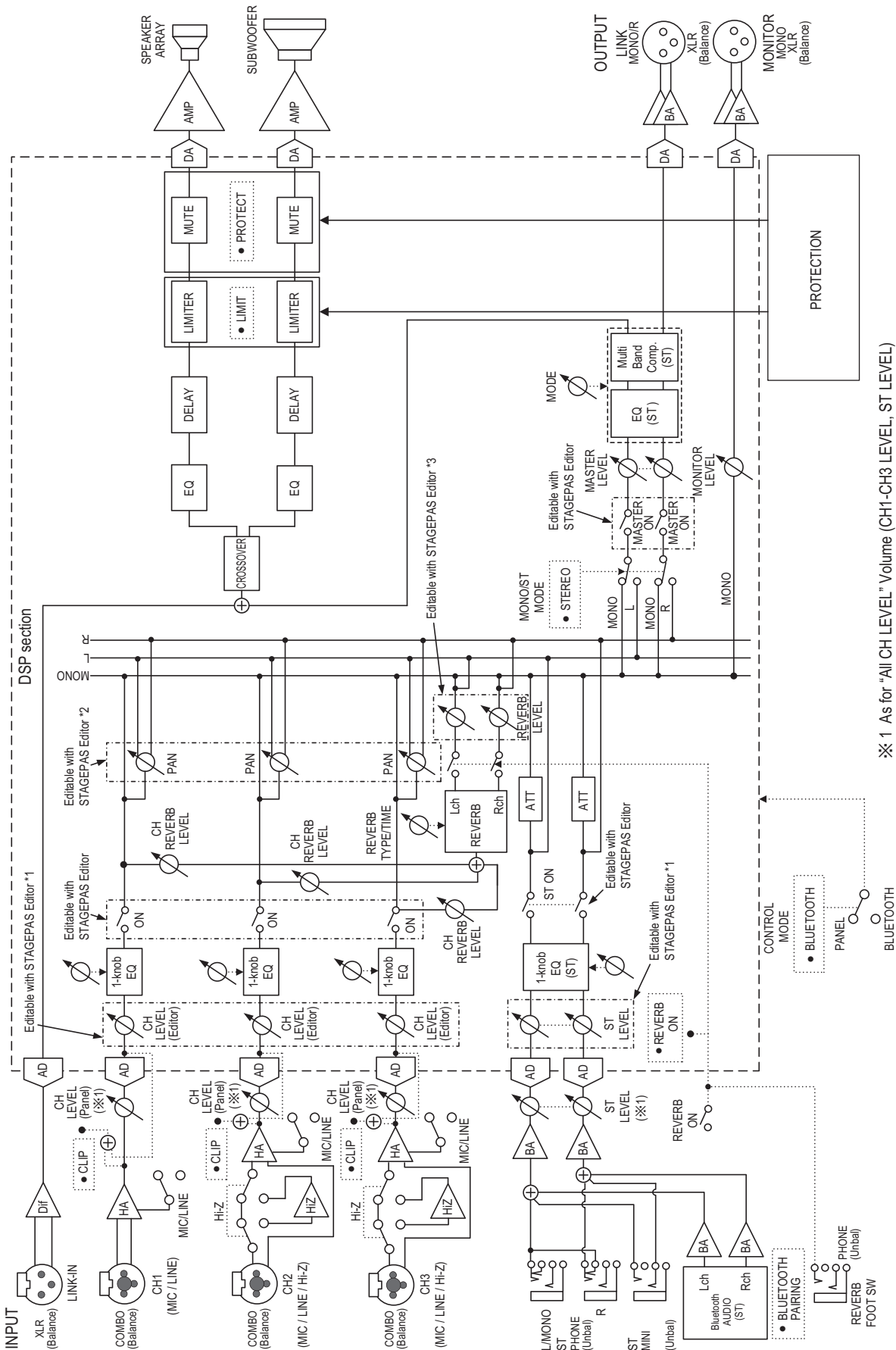

※ 1 As for "All CH LEVEL" Volume (CH1-CH3 LEVEL, ST LEVEL) nominal level: Center click position  
 ※ 1 At the "Control panel mode", CH LEVEL settings are fixed at 0 dB position.  
 ※ 2 At the "Control panel mode", PAN settings are fixed at center position.  
 ※ 3 At the "Control panel mode", REVERB LEVEL settings are fixed at -3 dB position.

This transmitter must not be co-located or operated in conjunction with any other antenna or transmitter.

This device complies with Industry Canada's licence-exempt RSSs. Operation is subject to the following two conditions:  
(1) this device may not cause interference, and  
(2) this device must accept any interference, including interference that may cause undesired operation of the device.

Le présent appareil est conforme aux CNR d'Industrie Canada applicables aux appareils radio exempts de licence. L'exploitation est autorisée aux deux conditions suivantes :  
(1) l'appareil ne doit pas produire de brouillage, et  
(2) l'utilisateur de l'appareil doit accepter tout brouillage radioélectrique subi, même si le brouillage est susceptible d'en compromettre le fonctionnement.

This equipment complies with FCC/IC radiation exposure limits set forth for an uncontrolled environment and meets the FCC radio frequency (RF) Exposure Guidelines and RSS-102 of the IC radio frequency (RF) Exposure rules. This equipment has very low levels of RF energy that is deemed to comply without maximum permissive exposure evaluation (MPE).

Cet équipement est conforme aux limites d'exposition aux rayonnements énoncées pour un environnement non contrôlé et respecte les règles des radioélectriques (RF) de la FCC lignes directrices d'exposition et d'exposition aux fréquences radioélectriques (RF) CNR-102 de l'IC. Cet équipement émet une énergie RF très faible qui est considérée comme conforme sans évaluation de l'exposition maximale autorisée (MPE).

<b>EN</b>	<b>SIMPLIFIED EU DECLARATION OF CONFORMITY</b>
<p>Hereby, Yamaha Music Europe GmbH declares that the radio equipment type STAGEPAS 1K is in compliance with Directive 2014/53/EU. The full text of the EU declaration of conformity is available at the following internet address: <a href="https://europe.yamaha.com/en/support/compliance/doc.html">https://europe.yamaha.com/en/support/compliance/doc.html</a></p>	
<b>FR</b>	<b>DECLARATION UE DE CONFORMITE SIMPLIFIEE</b>
<p>Le soussigné, Yamaha Music Europe GmbH, déclare que l'équipement radioélectrique du type STAGEPAS 1K est conforme à la directive 2014/53/EU. Le texte complet de la déclaration UE de conformité est disponible à l'adresse internet suivante: <a href="https://europe.yamaha.com/en/support/compliance/doc.html">https://europe.yamaha.com/en/support/compliance/doc.html</a></p>	
<b>DE</b>	<b>VEREINFACHTE EU-KONFORMITÄTSEKTLÄRUNG</b>
<p>Hiermit erklärt Yamaha Music Europe GmbH, dass der Funkanlagentyp STAGEPAS 1K der Richtlinie 2014/53/EU entspricht. Der vollständige Text der EU-Konformitätserklärung ist unter der folgenden Internetadresse verfügbar: <a href="https://europe.yamaha.com/en/support/compliance/doc.html">https://europe.yamaha.com/en/support/compliance/doc.html</a></p>	
<b>SV</b>	<b>FÖRENKLAD EU-FÖRSÄKRAN OM ÖVERENSSTÄMMELSE</b>
<p>Härmed försäkrar Yamaha Music Europe GmbH att denna typ av radioutrustning STAGEPAS 1K överensstämmer med direktiv 2014/53/EU. Den fullständiga texten till EU-försäkran om överensstämmelse finns på följande webbadress: <a href="https://europe.yamaha.com/en/support/compliance/doc.html">https://europe.yamaha.com/en/support/compliance/doc.html</a></p>	
<b>IT</b>	<b>DICHIARAZIONE DI CONFORMITÀ UE SEMPLIFICATA</b>
<p>Il fabbricante, Yamaha Music Europe GmbH, dichiara che il tipo di apparecchiatura radio STAGEPAS 1K è conforme alla direttiva 2014/53/UE. Il testo completo della dichiarazione di conformità UE è isponibile al seguente indirizzo Internet: <a href="https://europe.yamaha.com/en/support/compliance/doc.html">https://europe.yamaha.com/en/support/compliance/doc.html</a></p>	
<b>ES</b>	<b>DECLARACIÓN UE DE CONFORMIDAD SIMPLIFICADA</b>
<p>Por la presente, Yamaha Music Europe GmbH declara que el tipo de equipo radioeléctrico STAGEPAS 1K es conforme con la Directiva 2014/53/UE. El texto completo de la declaración UE de onformidad está isponible en la dirección Internet siguiente: <a href="https://europe.yamaha.com/en/support/compliance/doc.html">https://europe.yamaha.com/en/support/compliance/doc.html</a></p>	
<b>PT</b>	<b>DECLARAÇÃO UE DE CONFORMIDADE SIMPLIFICADA</b>
<p>O(a) abaixo assinado(a) Yamaha Music Europe GmbH declara que o presente tipo de equipamento de rádio STAGEPAS 1K está em conformidade com a Diretiva 2014/53/UE. O texto integral da declaração de conformidade está disponível no seguinte endereço de Internet: <a href="https://europe.yamaha.com/en/support/compliance/doc.html">https://europe.yamaha.com/en/support/compliance/doc.html</a></p>	
<b>NL</b>	<b>VEREENVOUDIGDE EU-CONFORMITEITSVERKLARING</b>
<p>Hierbij verklaar ik, Yamaha Music Europe GmbH, dat het type radioapparatuur STAGEPAS 1K conform is met Richtlijn 2014/53/EU. De volledige tekst van de EU-conformiteitsverklaring kan worden geraadpleegd op het volgende internetadres: <a href="https://europe.yamaha.com/en/support/compliance/doc.html">https://europe.yamaha.com/en/support/compliance/doc.html</a></p>	
<b>BG</b>	<b>ОПРОСТЕНА ЕС ДЕКЛАРАЦИЯ ЗА СЪОТВЕТСТВИЕ</b>
<p>С настоящото Yamaha Music Europe GmbH декларира, че този тип радиосъоръжение STAGEPAS 1K е в съответствие с Директива 2014/53/ЕС. Цялостният текст на ЕС декларацията за съответствие може да се намери на следния интернет адрес: <a href="https://europe.yamaha.com/en/support/compliance/doc.html">https://europe.yamaha.com/en/support/compliance/doc.html</a></p>	
<b>CS</b>	<b>ZJEDNODUŠENÉ EU PROHLÁŠENÍ O SHODĚ</b>
<p>Tímto Yamaha Music Europe GmbH prohlašuje, že typ rádiového zařízení STAGEPAS 1K je v souladu se směrnici 2014/53/EU. Úplné znění EU prohlášení o shodě je k dispozici na této internetové adrese: <a href="https://europe.yamaha.com/en/support/compliance/doc.html">https://europe.yamaha.com/en/support/compliance/doc.html</a></p>	
<b>DA</b>	<b>FORENKLET EU-OVERENSSTEMMELSESEKTLÆRING</b>
<p>Hermed erklærer Yamaha Music Europe GmbH, at radioudstyrstypen STAGEPAS 1K er i overensstemmelse med direktiv 2014/53/EU. EU-overensstemmelseerklæringens fulde tekst kan findes på følgende internetadresse: <a href="https://europe.yamaha.com/en/support/compliance/doc.html">https://europe.yamaha.com/en/support/compliance/doc.html</a></p>	
<b>ET</b>	<b>LIHTSUSTATUD ELI VASTAVUSDEKLARATSIOON</b>
<p>Käesolevaga deklareerib Yamaha Music Europe GmbH, et käesolev raadioseadme tüüp STAGEPAS 1K vastab direktiivi 2014/53/EL nõuetele. ELi vastavusdeklaratsiooni täielik tekst on kättesaadav järgmisel internetiaadressil: <a href="https://europe.yamaha.com/en/support/compliance/doc.html">https://europe.yamaha.com/en/support/compliance/doc.html</a></p>	
<b>EL</b>	<b>ΑΠΛΟΥΣΤΕΥΜΕΝΗ ΔΗΛΩΣΗ ΣΥΜΜΟΡΦΩΣΗΣ ΕΕ</b>
<p>Με την παρούσα ο/η Yamaha Music Europe GmbH, δηλώνει ότι ο ραδιοεξοπλισμός STAGEPAS 1K πληροί την οδηγία 2014/53/ΕΕ. Το πλήρες κείμενο της δήλωσης συμμόρφωσης ΕΕ διατίθεται στην ακόλουθη ιστοσελίδα στο διαδίκτυο: <a href="https://europe.yamaha.com/en/support/compliance/doc.html">https://europe.yamaha.com/en/support/compliance/doc.html</a></p>	
<b>HR</b>	<b>POJEDNOSTAVLJENA EU IZJAVA O SUKLADNOSTI</b>
<p>Yamaha Music Europe GmbH ovime izjavljuje da je radijska oprema tipa STAGEPAS 1K u skladu s Direktivom 2014/53/EU. Cjeloviti tekst EU izjave o sukladnosti dostupan je na sljedećoj internetskoj adresi: <a href="https://europe.yamaha.com/en/support/compliance/doc.html">https://europe.yamaha.com/en/support/compliance/doc.html</a></p>	
<b>LV</b>	<b>VIENKĀRŠOTA ES ATBILSTĪBAS DEKLARĀCIJA</b>
<p>Ar šo Yamaha Music Europe GmbH deklarē, ka radioiekārta STAGEPAS 1K atbilst Direktīvai 2014/53/ES. Pilns ES atbilstības deklarācijas teksts ir pieejams šādā interneta vietnē: <a href="https://europe.yamaha.com/en/support/compliance/doc.html">https://europe.yamaha.com/en/support/compliance/doc.html</a></p>	



<b>LT</b>	<b>SUPAPRASTINTA ES ATITIKTIES DEKLARACIJA</b>
Aš, Yamaha Music Europe GmbH, patvirtinu, kad radijo įrenginių tipas STAGEPAS 1K atitinka Direktyvą 2014/53/ES. Visas ES atitikties deklaracijos tekstas prieinamas šiuo interneto adresu: <a href="https://europe.yamaha.com/en/support/compliance/doc.html">https://europe.yamaha.com/en/support/compliance/doc.html</a>	
<b>HU</b>	<b>EGYSZERŰSÍTETT EU-MEGFELELŐSÉGI NYILATKOZAT</b>
Yamaha Music Europe GmbH igazolja, hogy a STAGEPAS 1K típusú rádióberendezés megfelel a 2014/53/EU irányelvnek. Az EU-megfelelőségi nyilatkozat teljes szövege elérhető a következő internetes címen: <a href="https://europe.yamaha.com/en/support/compliance/doc.html">https://europe.yamaha.com/en/support/compliance/doc.html</a>	
<b>PL</b>	<b>UPROSZCZONA DEKLARACJA ZGODNOŚCI UE</b>
Yamaha Music Europe GmbH niniejszym oświadcza, że typ urządzenia radiowego STAGEPAS 1K jest zgodny z dyrektywą 2014/53/UE. Pełny tekst deklaracji zgodności UE jest dostępny pod następującym adresem internetowym: <a href="https://europe.yamaha.com/en/support/compliance/doc.html">https://europe.yamaha.com/en/support/compliance/doc.html</a>	
<b>RO</b>	<b>DECLȚIA ARAUE DE CONFORMITATE SIMPLIFICATĂ</b>
Prin prezenta, Yamaha Music Europe GmbH declară că tipul de echipamente radio STAGEPAS 1K este în conformitate cu Directiva 2014/53/UE. Textul integral al declarației UE de conformitate este disponibil la următoarea adresă internet: <a href="https://europe.yamaha.com/en/support/compliance/doc.html">https://europe.yamaha.com/en/support/compliance/doc.html</a>	
<b>SK</b>	<b>ZJEDNODUŠENÉ EÚ VYHLÁSENIE O ZHODE</b>
Yamaha Music Europe GmbH týmto vyhlasuje, že rádiové zariadenie typu STAGEPAS 1K je v súlade so smernicou 2014/53/EÚ. Úplné EÚ vyhlásenie o zhode je k dispozícii na tejto internetovej adrese: <a href="https://europe.yamaha.com/en/support/compliance/doc.html">https://europe.yamaha.com/en/support/compliance/doc.html</a>	
<b>SL</b>	<b>POENOSTAVLJENA IZJAVA EU O SKLADNOSTI</b>
Yamaha Music Europe GmbH potrjuje, da je tip radijske opreme STAGEPAS 1K skladen z Direktivo 2014/53/EU. Celotno besedilo izjave EU o skladnosti je na voljo na naslednjem spletnem naslovu: <a href="https://europe.yamaha.com/en/support/compliance/doc.html">https://europe.yamaha.com/en/support/compliance/doc.html</a>	
<b>FI</b>	<b>YKSINKERTAISTETTU EU-VAATIMUSTENMUKAISUUSVAKUUTUS</b>
Yamaha Music Europe GmbH vakuuttaa, että radiolaitetyyppi STAGEPAS 1K on direktiivin 2014/53/EU mukainen. EU-vaatimustenmukaisuusvakuutuksen täysimittainen teksti on saatavilla seuraavassa internetosoitteessa: <a href="https://europe.yamaha.com/en/support/compliance/doc.html">https://europe.yamaha.com/en/support/compliance/doc.html</a>	
<b>TR</b>	<b>BASİTLEŞTİRİLMİŞ AVRUPA BİRLİĞİ UYGUNLUK BİLDİRİMİ</b>
İşbu belge ile, Yamaha Music Europe GmbH, radyo cihaz tipinin STAGEPAS 1K, Direktif 2014/53/AB'ye uygunluğunu beyan eder. AB uyumu beyanının tam metni aşağıdaki internet adresinden edinilebilir: <a href="https://europe.yamaha.com/en/support/compliance/doc.html">https://europe.yamaha.com/en/support/compliance/doc.html</a>	

#### Information for users on collection and disposal of old equipment:



This symbol on the products, packaging, and/or accompanying documents means that used electrical and electronic products should not be mixed with general household waste. For proper treatment, recovery and recycling of old products, please take them to applicable collection points, in accordance with your national legislation.

By disposing of these products correctly, you will help to save valuable resources and prevent any potential negative effects on human health and the environment which could otherwise arise from inappropriate waste handling.

For more information about collection and recycling of old products, please contact your local municipality, your waste disposal service or the point of sale where you purchased the items.

#### For business users in the European Union:

If you wish to discard electrical and electronic equipment, please contact your dealer or supplier for further information.

#### Information on Disposal in other Countries outside the European Union:

This symbol is only valid in the European Union. If you wish to discard these items, please contact your local authorities or dealer and ask for the correct method of disposal.

(weee\_eu\_en\_02)

### Informations concernant la collecte et le traitement des déchets d'équipements électriques et électroniques



Le symbole sur les produits, l'emballage et/ou les documents joints signifie que les produits électriques ou électroniques usagés ne doivent pas être mélangés avec les déchets domestiques habituels.

Pour un traitement, une récupération et un recyclage appropriés des déchets d'équipements électriques et électroniques, veuillez les déposer aux points de collecte prévus à cet effet, conformément à la réglementation nationale.



En vous débarrassant correctement des déchets d'équipements électriques et électroniques, vous contribuerez à la sauvegarde de précieuses ressources et à la prévention de potentiels effets négatifs sur la santé humaine qui pourraient advenir lors d'un traitement inapproprié des déchets.

Pour plus d'informations à propos de la collecte et du recyclage des déchets d'équipements électriques et électroniques, veuillez contacter votre municipalité, votre service de traitement des déchets ou le point de vente où vous avez acheté les produits.

#### **Pour les professionnels dans l'Union européenne :**

Si vous souhaitez vous débarrasser des déchets d'équipements électriques et électroniques, veuillez contacter votre vendeur ou fournisseur pour plus d'informations.

#### **Informations sur la mise au rebut dans d'autres pays en dehors de l'Union européenne :**

Ce symbole est seulement valable dans l'Union européenne. Si vous souhaitez vous débarrasser de déchets d'équipements électriques et électroniques, veuillez contacter les autorités locales ou votre fournisseur et demander la méthode de traitement appropriée.

(weee\_eu\_fr\_02)

### Información para usuarios sobre la recogida y eliminación de los equipos antiguos



Este símbolo en los productos, embalajes y documentos anexos significa que los productos eléctricos y electrónicos no deben mezclarse con los desperdicios domésticos normales.

Para el tratamiento, recuperación y reciclaje apropiados de los productos antiguos, llévelos a puntos de reciclaje correspondientes, de acuerdo con la legislación nacional.



Al deshacerse de estos productos de forma correcta, ayudará a ahorrar recursos valiosos y a impedir los posibles efectos desfavorables en la salud humana y en el entorno que de otro modo se producirían si se trataran los desperdicios de modo inapropiado.

Para obtener más información acerca de la recogida y el reciclaje de los productos antiguos, póngase en contacto con las autoridades locales, con el servicio de eliminación de basuras o con el punto de venta donde adquirió los artículos.

#### **Para los usuarios empresariales de la Unión Europea:**

Si desea desechar equipos eléctricos y electrónicos, póngase en contacto con su vendedor o proveedor para obtener más información.

#### **Información sobre la eliminación en otros países fuera de la Unión Europea:**

Este símbolo solo es válido en la Unión Europea. Si desea desechar estos artículos, póngase en contacto con las autoridades locales o con el vendedor y pregúnteles el método correcto.

(weee\_eu\_es\_02)

# Important Notice: Guarantee Information for customers in European Economic Area (EEA) and Switzerland

<b>Important Notice: Guarantee Information for customers in EEA* and Switzerland</b> For detailed guarantee information about this Yamaha product, and Pan-EEA* and Switzerland warranty service, please either visit the website address below (Printable file is available at our website) or contact the Yamaha representative office for your country. * EEA: European Economic Area	<b>English</b>
<b>Wichtiger Hinweis: Garantie-Information für Kunden in der EWR* und der Schweiz</b> Für nähere Garantie-Information über dieses Produkt von Yamaha, sowie über den Pan-EWR*- und Schweizer Garantieservice, besuchen Sie bitte entweder die folgend angegebene Internetadresse (eine druckfähige Version befindet sich auch auf unserer Webseite), oder wenden Sie sich an den für Ihr Land zuständigen Yamaha-Vertrieb. *EWR: Europäischer Wirtschaftsraum	<b>Deutsch</b>
<b>Remarque importante: informations de garantie pour les clients de l'EEE et la Suisse</b> Pour des informations plus détaillées sur la garantie de ce produit Yamaha et sur le service de garantie applicable dans l'ensemble de l'EEE ainsi qu'en Suisse, consultez notre site Web à l'adresse ci-dessous (le fichier imprimable est disponible sur notre site Web) ou contactez directement Yamaha dans votre pays de résidence. * EEE : Espace Economique Européen	<b>Français</b>
<b>Belangrijke mededeling: Garantie-informatie voor klanten in de EER* en Zwitserland</b> Voor gedetailleerde garantie-informatie over dit Yamaha-product en de garantieservice in heel de EER* en Zwitserland, gaat u naar de onderstaande website (u vindt een afdrukbaar bestand op onze website) of neemt u contact op met de vertegenwoordiging van Yamaha in uw land. * EER: Europese Economische Ruimte	<b>Nederlands</b>
<b>Aviso importante: información sobre la garantía para los clientes del EEE* y Suiza</b> Para una información detallada sobre este producto Yamaha y sobre el soporte de garantía en la zona EEE* y Suiza, visite la dirección web que se incluye más abajo (la versión del archivo para imprimir esta disponible en nuestro sitio web) o póngase en contacto con el representante de Yamaha en su país. * EEE: Espacio Económico Europeo	<b>Español</b>
<b>Avviso importante: informazioni sulla garanzia per i clienti residenti nell'EEA* e in Svizzera</b> Per informazioni dettagliate sulla garanzia relativa a questo prodotto Yamaha e l'assistenza in garanzia nei paesi EEA* e in Svizzera, potete consultare il sito Web all'indirizzo riportato di seguito (è disponibile il file in formato stampabile) oppure contattare l'ufficio di rappresentanza locale della Yamaha. * EEA: Area Economica Europea	<b>Italiano</b>
<b>Aviso importante: informações sobre as garantias para clientes da AEE* e da Suíça</b> Para obter uma informação pormenorizada sobre este produto da Yamaha e sobre o serviço de garantia na AEE* e na Suíça, visite o site a seguir (o arquivo para impressão está disponível no nosso site) ou entre em contato com o escritório de representação da Yamaha no seu país. * AEE: Área Económica Européia	<b>Português</b>
<b>Σημαντική σημείωση: Πληροφορίες εγγύησης για τους πελάτες στον EOX* και Ελβετία</b> Για λεπτομερείς πληροφορίες εγγύησης σχετικά με το παρόν προϊόν της Yamaha και την κάλυψη εγγύησης σε όλες τις χώρες του EOX και την Ελβετία, επισκεφτείτε την παρακάτω ιστοσελίδα (Εκτυπώσιμη μορφή είναι διαθέσιμη στην ιστοσελίδα μας) ή απευθυνθείτε στην αντιπροσωπεία της Yamaha στη χώρα σας. * EOX: Ευρωπαϊκός Οικονομικός Χώρος	<b>Ελληνικά</b>
<b>Viktigt: Garantiinformation för kunder i EES-området* och Schweiz</b> För detaljerad information om denna Yamahaprodukt samt garantiservice i hela EES-området* och Schweiz kan du antingen besöka nedanstående webbadress (en utskriftsvänlig fil finns på webbplatsen) eller kontakta Yamahas officiella representant i ditt land. * EES: Europeiska Ekonomiska Samarbetsområdet	<b>Svenska</b>
<b>Viktig merknad: Garantiinformasjon for kunder i EØS* og Sveits</b> Detaljert garantiinformasjon om dette Yamaha-produktet og garantiservice for hele EØS-området* og Sveits kan fås enten ved å besøke nettstedene nedenfor (utskriftsversjon finnes på våre nettsider) eller kontakte Yamahas kontoret i landet der du bor. *EØS: Det europeiske økonomiske samarbeidsområdet	<b>Norsk</b>
<b>Vigtig oplysning: Garantioplysninger til kunder i EØO* og Schweiz</b> De kan finde detaljerede garantioplysninger om dette Yamaha-produkt og den fælles garantiserviceordning for EØO* (og Schweiz) ved at besøge det websted, der er angivet nedenfor (der findes en fil, som kan udskrives, på vores websted), eller ved at kontakte Yamahas nationale repræsentationskontor i det land, hvor De bor. * EØO: Det Europæiske Økonomiske Område	<b>Dansk</b>
<b>Tärkeä ilmoitus: Takuutiedot Euroopan talousalueen (ETA)* ja Sveitsin asiakkaille</b> Tämän Yamaha-tuotteen sekä ETA-alueen ja Sveitsin takuuta koskevat yksityiskohtaiset tiedot saatte alla olevasta nettiosoitteesta. (Tulostettava tiedosto saatavissa sivustollamme.) Voitte myös ottaa yhteyttä paikalliseen Yamaha-edustajaan. *ETA: Euroopan talousalue	<b>Suomi</b>
<b>Ważne: Warunki gwarancyjne obowiązujące w EOG* i Szwajcarii</b> Aby dowiedzieć się więcej na temat warunków gwarancyjnych tego produktu firmy Yamaha i serwisu gwarancyjnego w całym EOG* i Szwajcarii, należy odwiedzić wskazaną poniżej stronę internetową (Plik gotowy do wydruku znajduje się na naszej stronie internetowej) lub skontaktować się z przedstawicielstwem firmy Yamaha w swoim kraju. * EOG — Europejski Obszar Gospodarczy	<b>Polski</b>
<b>Důležité oznámení: Záruční informace pro zákazníky v EHS* a ve Švýcarsku</b> Podrobné záruční informace o tomto produktu Yamaha a záručním servisu v celém EHS* a ve Švýcarsku naleznete na níže uvedené webové adrese (soubor k tisku je dostupný na našich webových stránkách) nebo se můžete obrátit na zástupce firmy Yamaha ve své zemi. * EHS: Evropský hospodářský prostor	<b>Česky</b>
<b>Fontos figyelmeltetés: Garancia-információk az EGT* területén és Svájcban élő vásárlók számára</b> A jelen Yamaha termékre vonatkozó részletes garancia-információk, valamint az EGT*-re és Svájcra kiterjedő garanciális szolgáltatás tekintetében keresse fel webhelyünket az alábbi címen (a webhelyen nyomtatható fájl is található), vagy pedig lépjen kapcsolatba az országában működő Yamaha képviselői irodával. * EGT: Európai Gazdasági Térség	<b>Magyar</b>
<b>Oluline märkus: Garantiiteave Euroopa Majanduspiirkonna (EMP)* ja Šveitsi klientidele</b> Täpsemat teabe saamiseks selle Yamaha toote garantii ning kogu Euroopa Majanduspiirkonna ja Šveitsi garantiiteeninduse kohta, külastage palun veebisaiti alljärgneval aadressil (meie saidil on saadaval printitav fail) või pöörduge Teie regiooni Yamaha esinduse poole. * EMP: Euroopa Majanduspiirkond	<b>Eesti keel</b>
<b>Svarīgs paziņojums: garantijas informācija klientiem EEZ* un Šveicē</b> Lai saņemtu detalizētu garantijas informāciju par šo Yamaha produktu, kā arī garantijas apkalpošanu EEZ* un Šveicē, lūdzu, apmeklējiet zemāk norādīto tīmekļa vietnes adresi (tīmekļa vietnē ir pieejams drukājams fails) vai sazinieties ar jūsu valsti apkalpojošo Yamaha pārstāvniecību. * EEZ: Eiropas Ekonomikas zona	<b>Latviešu</b>
<b>Dėmesio: informacija dėl garantijos pirkėjams EEE* ir Šveicarijoje</b> Jei reikia išsamios informacijos apie šį „Yamaha“ produktą ir jo techninę priežiūrą visoje EEE* ir Šveicarijoje, apsilankykite mūsų svetainėje toliau nurodytu adresu (svetainėje yra spausdintinas failas) arba kreipkitės į „Yamaha“ atstovybę savo šaliai. *EEE – Europos ekonominė erdvė	<b>Lietuvių kalba</b>
<b>Dôležité upozornenie: Informácie o záruke pre zákazníkov v EHP* a Švajčiarsku</b> Podrobné informácie o záruke týkajúce sa tohto produktu od spoločnosti Yamaha a garančnom servise v EHP* a Švajčiarsku nájdete na webovej stránke uvedenej nižšie (na našej webovej stránke je k dispozícii súbor na tlač) alebo sa obráťte na zástupcu spoločnosti Yamaha vo svojej krajine. * EHP: Európsky hospodársky priestor	<b>Slovenčina</b>
<b>Pomembno obvestilo: Informacije o garanciji za kupce v EGP* in Švici</b> Za podrobnejše informacije o tem Yamahinem izdelku ter garancijskem servisu v celotnem EGP in Švici, obiščite spletno mesto, ki je navedeno spodaj (natisljiva datoteka je na voljo na našem spletnem mestu), ali se obrnite na Yamahinega predstavnika v svoji državi. * EGP: Evropski gospodarski prostor	<b>Slovenščina</b>
<b>Важно съобщение: Информация за гаранцията за клиенти в ЕИП* и Швейцария</b> За подробна информация за гаранцията за този продукт на Yamaha и гаранционното обслужване в паневропейската зона на ЕИП* и Швейцария или посетете посещения по-долу уеб сайт (на нашия уеб сайт има файл за печат), или се свържете с представителния офис на Yamaha във вашата страна. * ЕИП: Европейско икономическо пространство	<b>Български език</b>
<b>Notificare importantă: Informații despre garanție pentru clienții din SEE* și Elveția</b> Pentru informații detaliate privind acest produs Yamaha și serviciul de garanție Pan-SEE* și Elveția, vizitați site-ul la adresa de mai jos (fișierul imprimabil este disponibil pe site-ul nostru) sau contactați biroul reprezentanței Yamaha din țara dumneavoastră. * SEE: Spațiul Economic European	<b>Limba română</b>
<b>Važna obavijest: Informacije o jamstvu za države EGP-a i Švicarske</b> Za detaljne informacije o jamstvu za ovaj Yamahin proizvod te jamstvenom servisu za cijeli EGP i Švicarsku, molimo Vas da posjetite web-stranicu navedenu u nastavku ili kontaktirate ovlaštenog Yamahinog dobavljača u svojoj zemlji. * EGP: Evropski gospodarski prostor	<b>Hrvatski</b>

<https://europe.yamaha.com/warranty/>

## ADDRESS LIST

### NORTH AMERICA

#### CANADA

**Yamaha Canada Music Ltd.**  
135 Milner Avenue, Toronto, Ontario,  
M1S 3R1, Canada  
Tel: +1-416-298-1311

#### U.S.A.

**Yamaha Corporation of America**  
6600 Orangethorpe Avenue, Buena Park, CA 90620,  
U.S.A.  
Tel: +1-714-522-9011

### CENTRAL & SOUTH AMERICA

#### MEXICO

**Yamaha de México, S.A. de C.V.**  
Av. Insurgentes Sur 1647 Piso 9, Col. San José  
Insurgentes, Delegación Benito Juárez, México,  
D.F., C.P. 03900, México  
Tel: +52-55-5804-0600

#### BRAZIL

**Yamaha Musical do Brasil Ltda.**  
Rua Fidêncio Ramos, 302 – Cj 52 e 54 – Torre B – Vila  
Olimpia – CEP 04551-010 – São Paulo/SP, Brazil  
Tel: +55-11-3704-1377

#### ARGENTINA

**Yamaha Music Latin America, S.A.,  
Sucursal Argentina**  
Olga Cossetini 1553, Piso 4 Norte,  
Madero Este-C1107CEK,  
Buenos Aires, Argentina  
Tel: +54-11-4119-7000

#### PANAMA AND OTHER LATIN

#### AMERICAN COUNTRIES/ CARIBBEAN COUNTRIES

**Yamaha Music Latin America, S.A.**  
Edif. Torre Banco General, Piso 7, Urbanización  
Marbella, Calle 47 y Aquilino de la Guardia,  
Ciudad de Panamá, República de Panamá  
Tel: +507-269-5311

### EUROPE

#### THE UNITED KINGDOM/IRELAND

**Yamaha Music Europe GmbH (UK)**  
Sherbourne Drive, Tilbrook, Milton Keynes,  
MK7 8BL, U.K.  
Tel: +44-1908-366700

#### GERMANY

**Yamaha Music Europe GmbH**  
Siemensstrasse 22-34, 25462 Rellingen, Germany  
Tel: +49-4101-303-0

#### SWITZERLAND/LIECHTENSTEIN

**Yamaha Music Europe GmbH, Branch  
Switzerland in Thalwil**  
Seestrasse 18a, 8800 Thalwil, Switzerland  
Tel: +41-44-3878080

#### AUSTRIA/BULGARIA/ CZECH REPUBLIC/HUNGARY/ ROMANIA/SLOVAKIA/SLOVENIA

**Yamaha Music Europe GmbH  
Branch Austria**  
Schleiergasse 20, 1100 Wien, Austria  
Tel: +43-1-60203900

#### POLAND

**Yamaha Music Europe GmbH  
Sp.z o.o. Oddział w Polsce**  
ul. Wielicka 52, 02-657 Warszawa, Poland  
Tel: +48-22-880-08-88

#### MALTA

**Olimpus Music Ltd.**  
Valletta Road, Mosta MST9010, Malta  
Tel: +356-2133-2093

### NETHERLANDS/BELGIUM/ LUXEMBOURG

**Yamaha Music Europe Branch Benelux**  
Clarissenhof 5b, 4133 AB Vianen, The Netherlands  
Tel: +31-347-358040

#### FRANCE

**Yamaha Music Europe**  
7 rue Ambroise Croizat, Zone d'activités de Pariest,  
77183 Croissy-Beaubourg, France  
Tel: +33-1-6461-4000

#### ITALY

**Yamaha Music Europe GmbH, Branch Italy**  
Via Tinelli N.67/69 20855 Gerno di Lesmo (MB),  
Italy  
Tel: +39-039-9065-1

#### SPAIN/PORTUGAL

**Yamaha Music Europe GmbH Ibérica, Sucursal  
en España**  
Ctra. de la Coruña km. 17,200, 28231  
Las Rozas de Madrid, Spain  
Tel: +34-91-639-88-88

#### GREECE

**Philippos Nakas S.A. The Music House**  
19th klm. Leof. Lavriou 190 02 Peania – Attiki,  
Greece  
Tel: +30-210-6686168

#### SWEDEN/FINLAND/ICELAND

**Yamaha Music Europe GmbH Germany filial  
Scandinavia**  
JA Wettergrensgata 1, 400 43 Göteborg, Sweden  
Tel: +46-31-89-34-00

#### DENMARK

**Yamaha Music Denmark,  
Fillial of Yamaha Music Europe GmbH, Tyskland**  
Generatorvej 8C, ST. TH. , 2860 Søborg, Denmark  
Tel: +45-44-92-49-00

#### NORWAY

**Yamaha Music Europe GmbH Germany -  
Norwegian Branch**  
Grini Næringspark 1, 1332 Østerås, Norway  
Tel: +47-6716-7800

#### CYPRUS

**Yamaha Music Europe GmbH**  
Siemensstrasse 22-34, 25462 Rellingen, Germany  
Tel: +49-4101-303-0

#### RUSSIA

**Yamaha Music (Russia) LLC.**  
Room 37, entrance 7, bld. 7, Kievskaya street,  
Moscow, 121059, Russia  
Tel: +7-495-626-5005

#### OTHER EUROPEAN COUNTRIES

**Yamaha Music Europe GmbH**  
Siemensstrasse 22-34, 25462 Rellingen, Germany  
Tel: +49-4101-3030

### AFRICA

**Yamaha Music Gulf FZE**  
JAFZA-16, Office 512, P.O.Box 17328,  
Jebel Ali FZE, Dubai, UAE  
Tel: +971-4-801-1500

### MIDDLE EAST

#### TURKEY

**Yamaha Music Europe GmbH  
Merkezi Almanya Türkiye İstanbul Şubesi**  
Mor Sumbul Sokak Varyap Meridian Business  
1.Blok No:1 113-114-115  
Bati Atasehir Istanbul, Turkey  
Tel: +90-216-275-7960

#### OTHER COUNTRIES

**Yamaha Music Gulf FZE**  
JAFZA-16, Office 512, P.O.Box 17328,  
Jebel Ali FZE, Dubai, UAE  
Tel: +971-4-801-1500

### ASIA

#### THE PEOPLE'S REPUBLIC OF CHINA

**Yamaha Music & Electronics (China) Co.,Ltd.**  
2F, Yunhedasha, 1818 Xinzha-lu, Jingan-qu,  
Shanghai, China  
Tel: +86-400-051-7700

#### INDIA

**Yamaha Music India Private Limited**  
P-401, JMD Megapolis, Sector-48, Sohna Road,  
Gurugram-122018, Haryana, India  
Tel: +91-124-485-3300

#### INDONESIA

**PT. Yamaha Musik Indonesia (Distributor)**  
Yamaha Music Center Bldg. Jalan Jend. Gatot  
Subroto Kav. 4, Jakarta 12930, Indonesia  
Tel: +62-21-520-2577

#### KOREA

**Yamaha Music Korea Ltd.**  
11F, Prudential Tower, 298, Gangnam-daero,  
Gangnam-gu, Seoul, 06253, Korea  
Tel: +82-2-3467-3300

#### MALAYSIA

**Yamaha Music (Malaysia) Sdn. Bhd.**  
No.8, Jalan Perbandaran, Kelana Jaya, 47301  
Petaling Jaya, Selangor, Malaysia  
Tel: +60-3-78030900

#### SINGAPORE

**Yamaha Music (Asia) Private Limited**  
Block 202 Hougang Street 21, #02-00,  
Singapore 530202, Singapore  
Tel: +65-6740-9200

#### TAIWAN

**Yamaha Music & Electronics Taiwan Co.,Ltd.**  
2F., No.1, Yuandong Rd., Banqiao Dist.,  
New Taipei City 22063, Taiwan (R.O.C.)  
Tel: +886-2-7741-8888

#### THAILAND

**Siam Music Yamaha Co., Ltd.**  
3, 4, 15, 16th Fl., Siam Motors Building,  
891/1 Rama 1 Road, Wangmai,  
Pathumwan, Bangkok 10330, Thailand  
Tel: +66-2215-2622

#### VIETNAM

**Yamaha Music Vietnam Company Limited**  
15th Floor, Nam A Bank Tower, 201-203 Cach  
Mang Thang Tam St., Ward 4, Dist.3,  
Ho Chi Minh City, Vietnam  
Tel: +84-8-3818-1122

#### OTHER ASIAN COUNTRIES

<http://asia.yamaha.com/>

### OCEANIA

#### AUSTRALIA

**Yamaha Music Australia Pty. Ltd.**  
Level 1, 80 Market Street, South Melbourne,  
VIC 3205, Australia  
Tel: +61-3-9693-5111

#### COUNTRIES AND TRUST

#### TERRITORIES IN PACIFIC OCEAN

<http://asia.yamaha.com/>