

## Replay Show DMX manager

Musikhaus Thomann  
Thomann GmbH  
Hans-Thomann-Straße 1  
96138 Burgebrach  
Germany  
Telephone: +49 (0) 9546 9223-0  
E-mail: [info@thomann.de](mailto:info@thomann.de)  
Internet: [www.thomann.de](http://www.thomann.de)

07.04.2020, ID: 474470

# Table of contents

<b>1</b>	<b>General information</b> .....	<b>5</b>
	1.1 Further information.....	6
	1.2 Notational conventions.....	7
	1.3 Symbols and signal words.....	8
<b>2</b>	<b>Safety instructions</b> .....	<b>10</b>
<b>3</b>	<b>Features</b> .....	<b>14</b>
<b>4</b>	<b>Installation and starting up</b> .....	<b>15</b>
<b>5</b>	<b>Connections and controls</b> .....	<b>18</b>
<b>6</b>	<b>Operating</b> .....	<b>23</b>
	6.1 Starting the device.....	23
	6.2 Setting the operating modes.....	23
	6.3 Control via app.....	33
	6.4 Software update.....	35
<b>7</b>	<b>Technical specifications</b> .....	<b>36</b>
<b>8</b>	<b>Plug and connection assignments</b> .....	<b>38</b>

**9 Protecting the environment..... 39**

# 1 General information

This user manual contains important information on the safe operation of the device. Read and follow all safety notes and all instructions. Save this manual for future reference. Make sure that it is available to all persons using this device. If you sell the device to another user, be sure that they also receive this manual.

Our products and user manuals are subject to a process of continuous development. We therefore reserve the right to make changes without notice. Please refer to the latest version of the user manual which is ready for download under [www.thomann.de](http://www.thomann.de).

## 1.1 Further information

On our website ([www.thomann.de](http://www.thomann.de)) you will find lots of further information and details on the following points:

Download	This manual is also available as PDF file for you to download.
Keyword search	Use the search function in the electronic version to find the topics of interest for you quickly.
Online guides	Our online guides provide detailed information on technical basics and terms.
Personal consultation	For personal consultation please contact our technical hotline.
Service	If you have any problems with the device the customer service will gladly assist you.

## 1.2 Notational conventions

This manual uses the following notational conventions:

### Letterings

The letterings for connectors and controls are marked by square brackets and italics.

**Examples:** *[VOLUME]* control, *[Mono]* button.

### Displays

Texts and values displayed on the device are marked by quotation marks and italics.

**Examples:** *'24ch'*, *'OFF'*.

### Text input

Text inputs that are carried out on the device are indicated by typewriter font.

**Example:** 2323

### Instructions

The individual steps of an instruction are numbered consecutively. The result of a step is indented and highlighted by an arrow.



#### Example:

1. ▶ Switch on the device.
2. ▶ Press *[Auto]*.
  - ⇒ Automatic operation is started.
3. ▶ Switch off the device.

## 1.3 Symbols and signal words

In this section you will find an overview of the meaning of symbols and signal words that are used in this manual.



Signal word	Meaning
<b>DANGER!</b>	This combination of symbol and signal word indicates an immediate dangerous situation that will result in death or serious injury if it is not avoided.
<b>NOTICE!</b>	This combination of symbol and signal word indicates a possible dangerous situation that can result in material and environmental damage if it is not avoided.
Warning signs	Type of danger
	Warning – high-voltage.
	Warning – danger zone.

## 2 Safety instructions

### Intended use

This device is used for real-time recording, playback and distribution of DMX signals via LAN or WLAN. Use the device only as described in this user manual. Any other use or use under other operating conditions is considered to be improper and may result in personal injury or property damage. No liability will be assumed for damages resulting from improper use.

This device may be used only by persons with sufficient physical, sensorial, and intellectual abilities and having corresponding knowledge and experience. Other persons may use this device only if they are supervised or instructed by a person who is responsible for their safety.

### Safety



#### **DANGER!**

#### **Danger for children**

Ensure that plastic bags, packaging, etc. are disposed of properly and are not within reach of babies and young children. Choking hazard!

Ensure that children do not detach any small parts (e.g. knobs or the like) from the unit. They could swallow the pieces and choke!

Never let children unattended use electrical devices.



**DANGER!**

**Electric shock caused by high voltages inside**

Within the device there are areas where high voltages may be present. Never remove any covers.

There are no user-serviceable parts inside.

Do not use the device if covers, protectors or optical components are missing or damaged.



**NOTICE!**

**Risk of fire**

Do not block areas of ventilation. Do not install the device near any direct heat source. Keep the device away from naked flames.



### **NOTICE!**

#### **Operating conditions**

This device has been designed for indoor use only. To prevent damage, never expose the device to any liquid or moisture. Avoid direct sunlight, heavy dirt, and strong vibrations.

Only operate the device within the ambient conditions specified in the chapter 'Technical specifications' of this user manual. Avoid heavy temperature fluctuations and do not switch the device on immediately after it was exposed to temperature fluctuations (for example after transport at low outside temperatures).

Dust and dirt inside can damage the unit. When operated in harmful ambient conditions (dust, smoke, nicotine, fog, etc.), the unit should be maintained by qualified service personnel at regular intervals to prevent overheating and other malfunction.



**NOTICE!**

**External power supply**

The device is powered by an external power supply. Before connecting the external power supply, ensure that the input voltage (AC outlet) matches the voltage rating of the device and that the AC outlet is protected by a residual current circuit breaker. Failure to do so could result in damage to the device and possibly the user.

Unplug the external power supply before electrical storms occur and when the device is unused for long periods of time to reduce the risk of electric shock or fire.



**NOTICE!**

**Possible damage due to installation of a wrong fuse**

The use of different types of fuses can cause serious damage to the unit. Fire hazard!

Only fuses of the same type may be used.

### 3 Features

DMX manager with the following features:

- DMX recorder and Art-Net-Node with wireless function
- 2 DMX universes (1024 DMX channels)
- Real-time recording and playback of DMX and Art-Net signals
- Built-in WiFi access point
- Art-Net in / out via RJ45 socket or WLAN
- 8 directly recallable memory locations, each with up to 20 hours of recording capacity
- Operation via buttons and display on the device as well as via Android and iOS applications (e.g. Aurora DMX, Photon, ArtNetDMXRemote)
- 2 playback modes: Single playback or endless loop
- Dimmer and speed control
- 2in1 DMX merge (HTP / LTP / Override / Backup)
- 1in2 DMX splitter (adjustable via buttons and display)
- Power supply via Power Twist or USB port
- Includes SD card (16 GB) for storing the shows
- Robust metal housing

## 4 Installation and starting up

Unpack and check carefully there is no transportation damage before using the unit. Keep the equipment packaging. To fully protect the product against vibration, dust and moisture during transportation or storage use the original packaging or your own packaging material suitable for transport or storage, respectively.

Create all connections while the device is off. Use the shortest possible high-quality cables for all connections. Take care when running the cables to prevent tripping hazards.



### **NOTICE!**

#### **Possible data transmission errors**

For error-free operation make use of dedicated DMX cables and do not use ordinary microphone cables.

Never connect the DMX input or output to audio devices such as mixers or amplifiers.

## Connections in 'DMX' mode

Connect the output of the first DMX device to the input of the second one and so on, to form a series connection. Connect the output of this DMX chain to input A on the front or back of the DMX Manager. Connect the output of a second DMX chain to input B on the front or back of the DMX Manager. Connect the output on the front or rear of the DMX Manager to the DMX input of a DMX controller or other DMX device. Make sure that the output of the last DMX device in the chain is terminated by a resistor (110  $\Omega$ , 1/4 W). Note that the ports on the front and back can not be used in parallel.

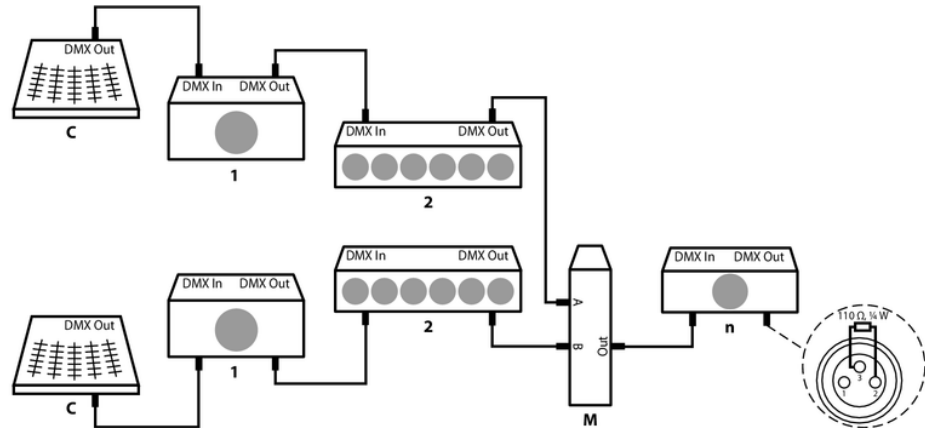



**DMX indicator**

While both the device and the DMX manager are in operation, the DMX indicators *[DMX IN 1]/ [DMX IN 2]* show that a DMX signal is being received on the input.

**Rack mounting**

The unit has been designed for rack mounting in a standard 19" rack; it occupies one rack unit.

## 5 Connections and controls

### Front panel

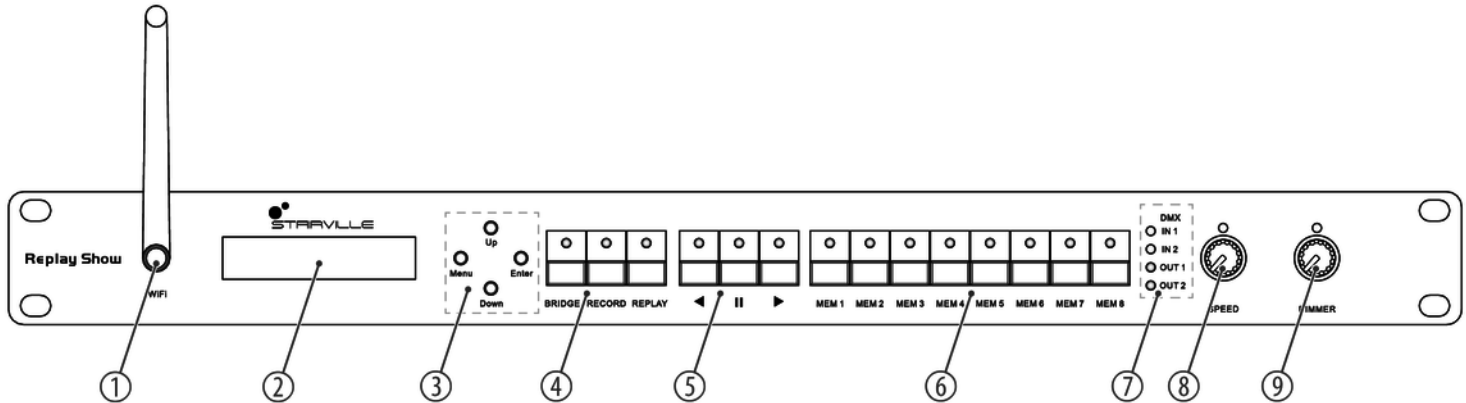

1	<i>[WiFi]</i> Unscrewable WLAN antenna
2	Display
3	<i>[MENU]</i> Button to activate the main menu and to switch between the menu items. Closes an opened submenu.
	<i>[UP] / [DOWN]</i> Button to switch between the menu items of a menu level, increases or decreases the displayed value by one.
	<i>[ENTER]</i> Button to confirm the set value.
4	<i>[BRIDGE] / [RECORD] / [PLAY]</i> Buttons to select the operating mode
5	◀ /    / ▶ Buttons for controlling the recording and playback functions

6	<i>[MEM 1]...[MEM 8]</i> Buttons to select the memory locations
7	<i>[DMX IN 1] / [DMX IN 2]</i> Status display. The indicator LED for the DMX input lights up green as soon as a signal is received.
	<i>[DMX OUT 1] / [DMX OUT 2]</i> Status display. The indicator LED for the DMX output lights up red as soon as a signal is sent.
8	<i>[SPEED]</i> Rotary control for adjusting the speed
9	<i>[DIMMER]</i> Rotary control for adjusting the brightness

Rear panel

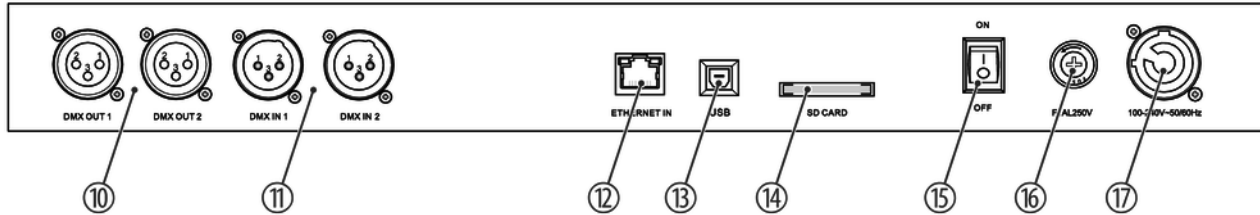

10 [DMX OUT 1] / [DMX OUT 2]  
2 × DMX output, designed as XLR socket

11 [DMX IN 1] / [DMX IN 2]  
2 × DMX input, designed as XLR plug

12	<i>[ETHERNET IN]</i> Network connection, designed as RJ45 socket, for data input and output
13	<i>[USB]</i> USB 2.0, type B for alternative power supply
14	<i>[SD CARD]</i> SD card slot for the supplied memory card
15	<i>[ON] / [OFF]</i> Main switch. Turns the device on and off.
16	Fuse holder
17	Lockable input socket (Power Twist) for powering the device

## 6 Operating

### 6.1 Starting the device

Connect the device to the power grid and turn it on with the main switch to start operation. The display shows the current firmware version. Press *[MENU]* to enter the main menu and make further settings.

### 6.2 Setting the operating modes

The device offers three different operating modes: BRIDGE, RECORD and PLAY.

#### 6.2.1 Operating mode Bridge

In BRIDGE mode, the device operates as a signal converter. In this mode, you can switch the device to splitter or merge mode.

Menu level 1	Menu level 2
'Bridge Mode01'	'IN1/2>OUT1/2'
'DMXin>DMXout'	'IN1>OUT1&2'
	'IN2>OUT1&2'
'Bridge Mode02'	
'DMXin>LAN'	
Signal input: DMX inputs, signal output: LAN socket	
'Bridge Mode03'	
'LAN>DMXout'	
Signal input: LAN socket, signal output: DMX outputs	



Menu level 1	Menu level 2
<p><i>'Bridge Mode04'</i></p> <p><i>'WiFi&gt;DMXout'</i></p> <p>Signal input: WLAN, signal output: DMX outputs</p>	
<p><i>'Bridge Mode05'</i></p> <p><i>'WiFi&gt;LAN'</i></p> <p>Signal input: WLANasD, signal output: LAN socket</p>	
<p><i>'Bridge Mode06'</i></p> <p><i>'DMX MERGE'</i></p>	<i>'HTP'</i>
	<i>'LTP'</i>
	<i>'override'</i>
	<i>'backup'</i>

## 6.2.1.1 SPLITTER operation

In SPLITTER mode, the device has three different ways to divide incoming signals.

1. ➤ Press *[BRIDGE]* to enter BRIDGE mode. The LED lights.
2. ➤ Press *[UP]* or *[DOWN]* until the display shows 'Bridge Mode01' and confirm with *[ENTER]*.
3. ➤ Press *[UP]* or *[DOWN]* until the display shows the desired signal distribution and confirm with *[ENTER]*.

Display	Function
'IN1/2>OUT1/2'	Inputs <i>[DMX IN 1]</i> and <i>[DMX IN 2]</i> distribute the signals to the outputs <i>[DMX OUT 1]</i> and <i>[DMX OUT 2]</i>
'IN1>OUT1&2'	Input <i>[DMX IN 1]</i> distributes the signals to the outputs <i>[DMX OUT 1]</i> and <i>[DMX OUT 2]</i>
'IN2>OUT1&2'	Input <i>[DMX IN 2]</i> distributes the signals to the outputs <i>[DMX OUT 1]</i> and <i>[DMX OUT 2]</i>

### 6.2.1.2 MERGE operation

#### HTP (High Take Precedence Modus)

In MERGE mode, the device has four different ways to merge DMX signals into a new signal: HTP, LTP, Override and Backup.

In HTP mode, the highest DMX value has priority.

1. ➤ Press *[BRIDGE]* to enter BRIDGE mode. The LED lights.
2. ➤ Press *[UP]* or *[DOWN]* until the display shows 'Bridge Mode06' and confirm with *[ENTER]*.
3. ➤ Press *[UP]* or *[DOWN]* until the display shows 'HTP' and confirm with *[ENTER]*.
  - ⇒ The HTP mode is activated. If two DMX signals are present at the inputs of the device, then the signal with the higher value overwrites the other signal.
4. ➤ Press *[UP]* or *[DOWN]* to increase or decrease the DMX value for 'DMX1' and confirm with 'ENTER'.
5. ➤ Press *[UP]* or *[DOWN]* to increase or decrease the DMX value for 'DMX2' and confirm with 'ENTER'.
6. ➤ Press *[MENU]* to return to the parent menu level.

### LTP (Latest Takes Precedence)

In LTP mode, the last DMX value has priority.

1. ➤ Press *[BRIDGE]* to enter BRIDGE mode. The LED lights.
2. ➤ Press *[UP]* or *[DOWN]* until the display shows '*Bridge Mode06*' and confirm with *[ENTER]*.
3. ➤ Press *[UP]* or *[DOWN]* until the display shows '*LTP*' and confirm with *[ENTER]*.
  - ⇒ The LTP mode is activated. If two DMX signals are present at the inputs of the device, then the last two changed values are applied.

### OVERRIDE

In OVERRIDE mode, the signals of both DMX inputs are combined to form a new signal specifying a start address.

1. ➤ Press *[BRIDGE]* to enter BRIDGE mode. The LED lights.
2. ➤ Press *[UP]* or *[DOWN]* until the display shows '*Bridge Mode06*' and confirm with *[ENTER]*.
3. ➤ Press *[UP]* or *[DOWN]* until the display shows '*override*' and confirm with *[ENTER]*.
4. ➤ Press *[UP]* or *[DOWN]* to increase or decrease the DMX value for '*DMX1*' and confirm with '*ENTER*'.

5. ▶ Press *[UP]* or *[DOWN]* to increase or decrease the DMX value for 'DMX2' and confirm with 'ENTER'.
  - ⇒ The operating mode Override is activated. The signals of both DMX inputs are combined to form a new signal specifying a start address.

## BACKUP

In BACKUP mode, the signal of the other input is accepted if no DMX signal is present at one input.

1. ▶ Press *[BRIDGE]* to enter BRIDGE mode. The LED lights.
2. ▶ Press *[UP]* or *[DOWN]* until the display shows 'Bridge Mode06' and confirm with *[ENTER]*.
3. ▶ Press *[UP]* or *[DOWN]* until the display shows 'backup' and confirm with *[ENTER]*.
  - ⇒ The BACKUP mode is activated. If a DMX signal is present at input 1, it is output at the device output. If no DMX signal is present at input 1, then the signal from input 2 is output at the device output.

## 6.2.2 Operating mode Record

In RECORD mode, the data of a light show can be recorded via Ethernet (LAN), WLAN or the two DMX inputs. There are 8 memory slots, each with up to 20 hours of recording capacity. The data is stored on the included SD card .

1. ➤ Press *[RECORD]* to enter the RECORD mode. The LED lights.
2. ➤ Use *[UP]* / *[DOWN]* to select one of the four recording modes

Menu	Input	Output
'Record Mode01'	DMX	SD card, DMX
'Record Mode02'	Art-Net via LAN	SD card, DMX
'Record Mode03'	Art-Net via WLAN	SD card, DMX
'Record Mode04'	Art-Net via WLAN	SD card, LAN

3. ➤ Confirm with *[ENTER]*.
4. ➤ Select one of the memory locations *[MEM 1]*...*[MEM 8]*. The LED lights.
  - ⇒ The display will show the selected memory location, the recording time and the error code ( 'err: -' = no error during recording, 'err: x' = Error during recording).

5. ▶ Press ▶ to start recording, || to pause recording or ◀ to stop recording and save.

### 6.2.3 Operating mode Replay

In the REPLAY mode, you can play the recordings individually or in an endless loop directly on the device or via your Android or iOS device.

1. ▶ Press [REPLAY] to enter REPLAY mode. The LED lights.
  - ⇒ The unit automatically returns to the last selected playback mode.
2. ▶ Select one of the memory locations [MEM 1]...[MEM 8]. The LED flashes. For memory locations with stored data, the LED lights up. Unused memory locations can not be selected.
3. ▶ To play back a single recording, press || or ◀/▶ to play the recording of the used memory locations in an endless loop.
  - ⇒ The direction of the arrow keys indicate the direction of the playback for the memory locations.
4. ▶ With the [SPEED] control you can set the speed of the stored light show between values of 25% (slow) to 200% (fast).

5. ▶ With the *[DIMMER]* control you can set the brightness of the stored light show between values of 0 % (dark) to 100 % (bright).
6. ▶ Press again **||**, **◀** or **▶** to stop playback.



## 6.3 Control via app

You can control the device's recording function from your Android and iOS devices.

1. ➤ Download the app from the PlayStore or AppStore of your Android or iOS device.
2. ➤ Press *[BRIDGE]* to enter BRIDGE mode. The LED lights.
3. ➤ Use *[UP]* or *[DOWN]* to select the menu item '*Mode 04 WiFi > DMX OUT*' and confirm with *[ENTER]*.
4. ➤ Select *[MENU]* to return to the main menu.
5. ➤ Use *[UP]* / *[DOWN]* to select the menu item '*System Setup [WiFi]*' and confirm with *[ENTER]*.  
⇒ Now you can do the network settings.
6. ➤ Use *[UP]* / *[DOWN]* to select the menu item '*WiFi-ArtNet [Local]*' and confirm with *[ENTER]*.
7. ➤ Use *[UP]* / *[DOWN]* to select the menu item '*WiFi Local Set [SSID]*' and enter the SSID of the DMX manager.
8. ➤ Use *[UP]* / *[DOWN]* to select the menu item '*WiFi Local Set [IP-Address]*' and enter the IP address of the DMX manager.

- 9.** ▶ Use *[UP]* / *[DOWN]* to select the menu item '*WiFi Local Set [Port-Address]*' and enter the port address of the DMX manager.
- 10.** ▶ Use *[UP]* / *[DOWN]* to select the menu item '*CWIFI SSID & IP*' and confirm with *[ENTER]* to apply the network settings.
- 11.** ▶ Connect your Android or iOS device to the DMX Manager. Enter the password 12345678.
- 12.** ▶ Launch the app on your Android or iOS device and go to Network Settings. Enter the password 12345678.
  - ⇒ The recording function of DMX Manager can now be controlled via your Android or iOS device.
- 13.** ▶ To reset the network settings, use *[UP]* / *[DOWN]* to select the menu item '*WiFi Local Set [Set Restore]*'. Enter the password 1224. Confirm with *[ENTER]*.

## 6.4 Software update

You can perform software updates using the supplied SD card.

1. ▶ Download the software update at [www.thomann.de](http://www.thomann.de) and save it in the main directory of the SD card.
2. ▶ Insert the SD card into the SD card slot [*SD CARD*].
3. ▶ Press [*MENU*] repeatedly until the display shows 'System setup [*new software*]' appears in the first line of the display.
4. ▶ Confirm with [*ENTER*].
  - ⇒ The software update will now be uploaded to the DMX manager.

## 7 Technical specifications

Operating modes	Bridge (HTP, LTP, Override, Backup), Record, Replay	
Control	Buttons and display on the device, Android and iOS applications (e.g. Aurora DMX, Photon, ArtNetDMXRemote)	
Input connections	Voltage supply	1 × lockable input socket (Power Twist) USB 2.0, type B
	DMX signal input	2 × XLR panel plug, 3-pin
	Ethernet / LAN	RJ45 socket
Output connections	DMX signal output	2 × XLR chassis socket, 3-pin
Preset LAN IP address	002,114,034,200	
Preset WLAN IP address	002,000,000,001	
Operating supply voltage	100 – 240 V ~ 50/60 Hz via Power Twist	
	5V via USB 2.0, type B	

Fuse	5 mm × 20 mm, 1 A, 250 V, fast-acting	
Mounting properties	19 inch, 1 RU	
Dimensions (W × H × D)	482 mm × 44 mm × 135 mm	
Weight	2.1 kg	
Ambient conditions	Temperature range	0 °C...40 °C
	Relative humidity	50 %, non-condensing

### Further information

External storage option	Yes
Max. DMX channels	1024

## 8 Plug and connection assignments

### Introduction

This chapter will help you select the right cables and plugs to connect your valuable equipment so that a perfect light experience is guaranteed.

Please take our tips, because especially in 'Sound & Light' caution is indicated: Even if a plug fits into a socket, the result of an incorrect connection may be a destroyed DMX controller, a short circuit or 'just' a not working light show!

### DMX connections



The unit offers a 3-pin XLR socket for DMX output and a 3-pin XLR plug for DMX input. Please refer to the drawing and table below for the pin assignment of a suitable XLR plug.

Pin	Configuration
1	Ground, shielding
2	Signal inverted (DMX-, 'cold signal')
3	Signal (DMX+, 'hot signal')

## 9 Protecting the environment

### Disposal of the packaging material



For the transport and protective packaging, environmentally friendly materials have been chosen that can be supplied to normal recycling.

Ensure that plastic bags, packaging, etc. are properly disposed of.

Do not just dispose of these materials with your normal household waste, but make sure that they are collected for recycling. Please follow the notes and markings on the packaging.

### Disposal of your old device



This product is subject to the European Waste Electrical and Electronic Equipment Directive (WEEE) in its currently valid version. Do not dispose with your normal household waste.

Dispose of this device through an approved waste disposal firm or through your local waste facility. When discarding the device, comply with the rules and regulations that apply in your country. If in doubt, consult your local waste disposal facility.





Replay Show





