

ignition

Co9 V2 LED Flood IP65 540W RGBW

User manual

LED floodlight

Musikhaus Thomann
Thomann GmbH
Hans-Thomann-Straße 1
96138 Burgebrach
Germany
Telephone: +49 (0) 9546 9223-0
E-mail: info@thomann.de
Internet: www.thomann.de

20.05.2020, ID: 477576

Table of contents

| | | |
|-----------|--|-----------|
| 1 | General information | 5 |
| 1.1 | Further information..... | 5 |
| 1.2 | Notational conventions..... | 5 |
| 1.3 | Symbols and signal words..... | 6 |
| 2 | Safety instructions | 7 |
| 3 | Features | 9 |
| 4 | Installation | 10 |
| 5 | Starting up | 12 |
| 6 | Connections and controls | 13 |
| 7 | Operating | 15 |
| 7.1 | Starting the device..... | 15 |
| 7.2 | Main menu..... | 16 |
| 7.2.1 | Operating mode 'DMX'..... | 20 |
| 7.2.2 | Operating mode 'Slave'..... | 20 |
| 7.2.3 | Operating mode 'Stand-alone'..... | 21 |
| 7.3 | Menu overview..... | 21 |
| 7.4 | Functions in 2-channel DMX mode..... | 22 |
| 7.5 | Functions in 3-channel DMX mode 1..... | 22 |
| 7.6 | Functions in 3-channel DMX mode 2..... | 23 |
| 7.7 | Functions in 4-channel DMX mode..... | 24 |
| 7.8 | Functions in 6-channel DMX mode..... | 24 |
| 7.9 | Functions in 13-channel DMX mode..... | 24 |
| 7.10 | Functions in 16-channel DMX mode..... | 27 |
| 7.11 | Functions in 29-channel DMX mode..... | 28 |
| 8 | Technical specifications | 31 |
| 9 | Plug and connection assignments | 32 |
| 10 | Troubleshooting | 33 |
| 11 | Cleaning | 34 |
| 12 | Protecting the environment | 35 |



1 General information

This user manual contains important information on the safe operation of the device. Read and follow all safety notes and all instructions. Save this manual for future reference. Make sure that it is available to all persons using this device. If you sell the device to another user, be sure that they also receive this manual.

Our products and user manuals are subject to a process of continuous development. We therefore reserve the right to make changes without notice. Please refer to the latest version of the user manual which is ready for download under www.thomann.de.

1.1 Further information

On our website (www.thomann.de) you will find lots of further information and details on the following points:

| | |
|-----------------------|---|
| Download | This manual is also available as PDF file for you to download. |
| Keyword search | Use the search function in the electronic version to find the topics of interest for you quickly. |
| Online guides | Our online guides provide detailed information on technical basics and terms. |
| Personal consultation | For personal consultation please contact our technical hotline. |
| Service | If you have any problems with the device the customer service will gladly assist you. |

1.2 Notational conventions

This manual uses the following notational conventions:

Letterings

The letterings for connectors and controls are marked by square brackets and italics.

Examples: *[VOLUME]* control, *[Mono]* button.

Displays





Texts and values displayed on the device are marked by quotation marks and italics.

Examples: '24ch', 'OFF'.

1.3 Symbols and signal words

In this section you will find an overview of the meaning of symbols and signal words that are used in this manual.

| Signal word | Meaning |
|-----------------|--|
| DANGER! | This combination of symbol and signal word indicates an immediate dangerous situation that will result in death or serious injury if it is not avoided. |
| WARNING! | This combination of symbol and signal word indicates a possible dangerous situation that can result in death or serious injury if it is not avoided. |
| NOTICE! | This combination of symbol and signal word indicates a possible dangerous situation that can result in material and environmental damage if it is not avoided. |

| Warning signs | Type of danger |
|---|--|
|  | Warning – high-voltage. |
|  | Warning – dangerous optical radiation. |
|  | Warning – suspended load. |
|  | Warning – danger zone. |

2 Safety instructions

Intended use

This device is intended for use as an electronic lighting effect by means of LED technology. The device is designed for professional use and is not suitable for use in households. Use the device only as described in this user manual. Any other use or use under other operating conditions is considered to be improper and may result in personal injury or property damage. No liability will be assumed for damages resulting from improper use.

This device may be used only by persons with sufficient physical, sensorial, and intellectual abilities and having corresponding knowledge and experience. Other persons may use this device only if they are supervised or instructed by a person who is responsible for their safety.

Extend the life of the device by regular breaks in operation and avoid switching it on and off frequently. This device is not suitable for continuous use.

Safety

**DANGER!****Danger for children**

Ensure that plastic bags, packaging, etc. are disposed of properly and are not within reach of babies and young children. Choking hazard!

Ensure that children do not detach any small parts (e.g. knobs or the like) from the unit. They could swallow the pieces and choke!

Never let children unattended use electrical devices.

**DANGER!****Hazardous voltage**

The wiring, as well as all maintenance and repair work on the electrical installation of the device must only be performed by qualified electrical personnel. Failure to do so may result in electric shock and risk of fire and loss of life.

Before starting work on the electrical installation, the device must be turned volt-free.

**DANGER!****Electric shock caused by high voltages inside**

Within the device there are areas where high voltages may be present. Never remove any covers.

There are no user-serviceable parts inside.

Do not use the device if covers, protectors or optical components are missing or damaged.



WARNING!

Eye damage caused by high light intensity

Never look directly into the light source.



WARNING!

Risk of epileptic shock

Strobe lighting can trigger seizures in photosensitive epilepsy. Sensitive persons should avoid looking at strobe lights.



WARNING!

Risk of injury caused by falling objects

Make sure that the installation complies with the standards and rules that apply in your country. Always secure the device with a secondary safety attachment, such as a safety cable or a safety chain.

Secure the barn door with a safety cable on the spotlight after installation. The safety cable must run outside the barn door and must not interfere with the light emission.



NOTICE!

Risk of fire

Do not block areas of ventilation. Do not install the device near any direct heat source. Keep the device away from naked flames.



NOTICE!

Power supply

Before connecting the device, ensure that the input voltage (AC outlet) matches the voltage rating of the device and that the AC outlet is protected by a residual current circuit breaker. Failure to do so could result in damage to the device and possibly injure the user.

Unplug the device before electrical storms occur and when it is unused for long periods of time to reduce the risk of electric shock or fire.



NOTICE!

Possible staining

The plasticiser contained in the rubber feet of this product may possibly react with the coating of your parquet, linoleum, laminate or PVC floor and after some time cause permanent dark stains.

In case of doubt, do not put the rubber feet directly on the floor, but use felt-pad floor protectors or a carpet.

3 Features

Special features of the device:

- 36 RGBW LEDs (each 15 W)
- Four separately controllable LED rows
- Operation in stand-alone and DMX mode (7 different modes)
- Simple operation via display and buttons on the unit
- Built-in automatic show programmes
- Automatic colour gradients
- Selectable dimmer curves
- Repetition frequency 3000 Hz
- Master / Slave mode
- Robust aluminium housing
- Due to protection class IP65, operation is also possible outdoors at times
- W-DMX module for wireless DMX control
- Barn doors, diffusion filter and two Omega brackets included
- Matching cases optionally available (2in1: Item no. 481159; 4in1: Item no. 481160; 6in1: Item no. 481161)

For technological reasons, the light output of LEDs decreases over their lifetime. This effect increases with higher operating temperature. You can extend the service life of the illuminants by providing adequate ventilation and operating the LEDs with the lowest possible brightness.

Information about protection class IP65

Equipment with protection class IP65 are dust-tight and completely protected against contact (first code number). They are also protected against splash water from any angle (second code digit). That is why this equipment can also be used outdoors. Event technology equipment is generally only designed for temporary use however (event lighting) and not for permanent use outdoors.

The specified protection class does not make a statement about the weather resistance of the equipment (resistance to changing ambient conditions as well as against the effects of sunlight and UV rays).

The seals and screw connections of the equipment must be checked regularly to ensure a fault-free operation. In cases of doubt, consult a specialist workshop in due time.

4 Installation

Unpack and check carefully there is no transportation damage before using the unit. Keep the equipment packaging. To fully protect the product against vibration, dust and moisture during transportation or storage use the original packaging or your own packaging material suitable for transport or storage, respectively.



DANGER!

Hazardous voltage

The wiring, as well as all maintenance and repair work on the electrical installation of the device must only be performed by qualified electrical personnel. Failure to do so may result in electric shock and risk of fire and loss of life.

Before starting work on the electrical installation, the device must be turned volt-free.



WARNING!

Risk of injury caused by falling objects

Make sure that the installation complies with the standards and rules that apply in your country. Always secure the device with a secondary safety attachment, such as a safety cable or a safety chain.

Secure the barn door with a safety cable on the spotlight after installation. The safety cable must run outside the barn door and must not interfere with the light emission.



NOTICE!

Risk of overheating

The distance between light output and the illuminated surface must be more than 1.5 m (19.7in).

Provide sufficient ventilation.

The ambient temperature must always be below 40 °C (104 °F).



NOTICE!

Use of stands

When mounting the device onto a stand, ensure that the stand is in a safe and stable position and that the weight of the device does not exceed the maximum permissible load capacity of the stand.

**NOTICE!****Possible data transmission errors**

For error-free operation make use of dedicated DMX cables and do not use ordinary microphone cables.

Never connect the DMX input or output to audio devices such as mixers or amplifiers.

**NOTICE!****Possible damage due to moisture**

Moisture entering into open connectors (plugs and couplers) of DMX or power cords can cause short circuits.

Close unused connectors with end caps intended for this purpose (www.thomann.de).

Mounting options

The quick lock openings on the housing bottom are used for secure attachment of the supplied Omega brackets. Here you can attach the flight adapters (such as the supplied C-hooks). The safety rope must pass through the notches on the bottom case as shown in the following figure.

You can install the unit in hanging or standing position. When in use, the device must always be attached to a solid surface or an approved truss.

Always work from a stable platform whenever installing, moving or servicing the unit. In doing so, the area underneath the unit must be cordoned off.

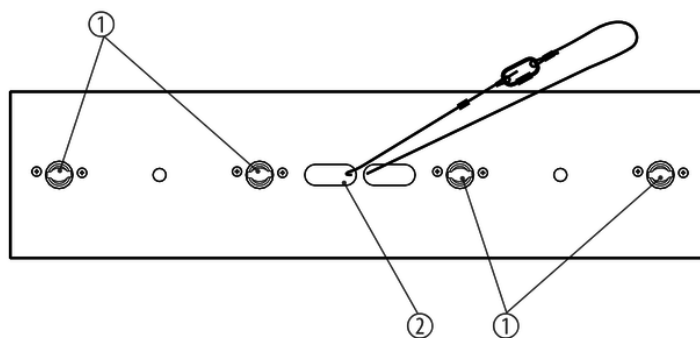

- | | |
|---|--|
| 1 | Quick lock openings for Omega brackets |
| 2 | Openings for safety cable |

5 Starting up

Create all connections while the device is off. Use the shortest possible high-quality cables for all connections. Take care when running the cables to prevent tripping hazards.

Connections in DMX mode

Connect the DMX input of the device to the DMX output of a DMX controller or another DMX device. Connect the output of the first DMX device to the input of the second one, and so on to form a daisy chain. Always ensure that the output of the last DMX device in the daisy chain is terminated with a resistor (110 Ω, ¼ W).

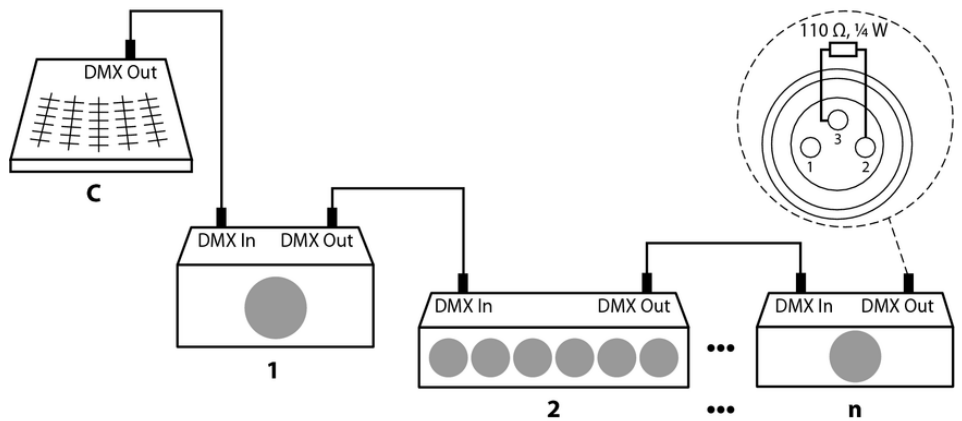

Connections in 'Master / Slave' mode

When you configure a group of devices in 'Master / Slave' mode, the first unit will control the others. This feature is especially useful to start a show without much programming. Connect the DMX output of the master unit to the DMX input of the first slave unit. Then connect the DMX output of the first slave unit to the DMX input of the second slave unit and so on.



Please note that this device must not be connected to a dimmer.

6 Connections and controls

Front panel

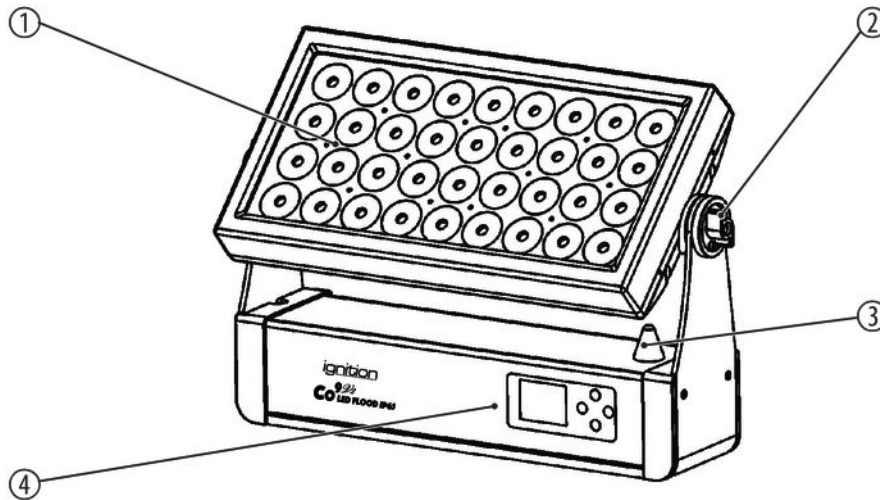

| | |
|---|--|
| 1 | Adjustable LED panel |
| 2 | Locking screw for the LED panel |
| 3 | Radio antenna |
| 4 | Control panel with display membrane button |
| | <i>[MENU]</i> Activates the main menu and toggles between menu items. Closes an opened submenu. |
| | <i>[UP]</i> Navigates upwards in a menu list. Increases the displayed value by one. |
| | <i>[DOWN]</i> Navigates downwards in a menu list. Decreases the displayed value by one. |
| | <i>[ENTER]</i> Selects an option of the respective operating mode, confirms the set value. |

Rear panel

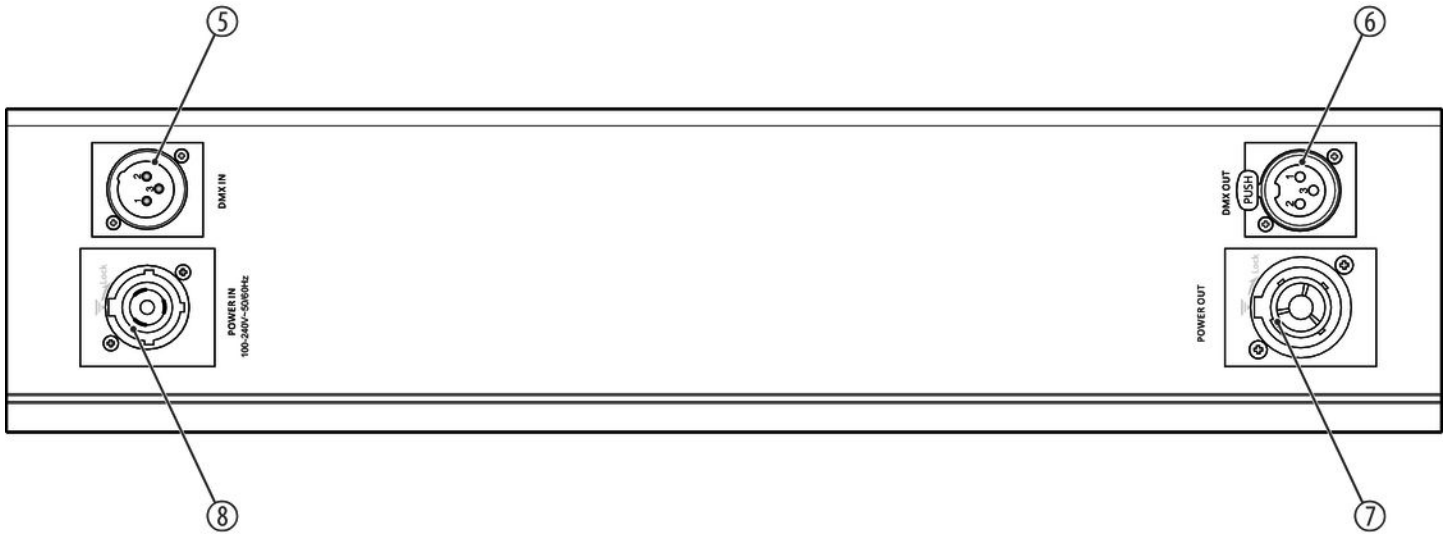

| | |
|---|---|
| 5 | <i>[DMX IN]</i> DMX input (3-pin XLR chassis plug, IP65 design) |
| 6 | <i>[DMX OUT]</i> DMX output (3-pin XLR chassis socket, IP65 design) |
| 7 | <i>[POWER IN]</i> Lockable chassis socket (Power Twist TR1 IP65) for the power supply of the device |
| 8 | <i>[POWER OUT]</i> Lockable chassis socket (Power Twist TR1 IP65) for the power supply of another device |

7 Operating

7.1 Starting the device

Connect the device to the power supply to start operation. After a few seconds, the display indicates that a reset is in progress. The device is then ready for use. The display shows the operating mode that was selected when the unit was last powered off.

If the DMX mode is set without a DMX signal being present, the display flashes.

7.2 Main menu

If the display is in standby, unlock it: Successively press *[UP]*, *[DOWN]*, *[UP]*, *[DOWN]* and *[ENTER]*.

Press *[MODE]* to activate the main menu. Use the buttons *[UP]* or *[DOWN]* to select a submenu. When the display shows the desired submenu, press *[ENTER]* to open it. To close the main menu, press *[MODE]*.

If you do not press any key for about 30 seconds, the main menu will be reactivated automatically.

All previously made settings are retained even when you disconnect the device from the power grid. To restart with default values, use the function 'Factory Reset'.

The following table shows the setting options.

| Main menu | Menu level 2 | Menu level 3 | Menu level 4 | |
|---------------|---------------------|--|--------------------------------|-----------------------|
| Meaning | | | | |
| 'DMX Address' | 'Set DMX address' | 001...512 | Setting the DMX address | |
| 'MODE' | 'DMX Signal Select' | Selection of the DMX transmission type | | |
| | | 'DMX' | DMX via cable | |
| | | 'Wireless DMX' | DMX via radio transmission | |
| | 'DMX Mode' | Selecting a DMX mode | | |
| | | 'DMX 2Ch' | 2-channel DMX mode | |
| | | 'DMX 3Ch1' | 3-channel DMX mode 1 | |
| | | 'DMX 3Ch2' | 3-channel DMX mode 1 | |
| | | 'DMX 4Ch' | 4-channel DMX mode | |
| | | 'DMX 6Ch' | 6-channel DMX mode | |
| | | 'DMX 13Ch' | 13-channel DMX mode | |
| | | 'DMX 16Ch' | 16-channel DMX mode | |
| | | 'DMX 29Ch' | 29-channel DMX mode | |
| | 'Slave' | 'Slave' | Operating mode 'Slave' | |
| | 'Auto' | 'Auto Fading' | 0...255 | Automatic Fade effect |
| | | 'Auto Jumping' | 0...255 | Automatic Jump effect |
| | 'Static' | 'Dimmer' | 0...255 | |
| | | | Setting the overall brightness | |
| | | 'Strobe' | Strobe effect | |
| | 0...5 | | Open strobe | |
| 6...10 | | | Closed strobe | |

| Main menu | Menu level 2 | Menu level 3 | Menu level 4 |
|-----------|--------------|------------------|--|
| Meaning | | | |
| | | | 11...33 Random Pulse effect with increasing speed |
| | | | 34...56 Ramp-up effect with increasing speed |
| | | | 57...79 Random Ramp-down effect with increasing speed |
| | | | 80...102 Random strobe effect with increasing speed |
| | | | 103...127 Strobe-burst effect with decreasing duration of interruptions |
| | | | 128...250 Strobe effect with increasing speed |
| | | | 251...255 Open strobe |
| | | 'Red' | 0...255 Intensity red (0 % to 100 %) |
| | | 'Green' | 0...255 Intensity green (0 % to 100 %) |
| | | 'Blue' | 0...255 Intensity blue (0 % to 100 %) |
| | | 'White' | 0...255 Intensity white (0 % to 100 %) |
| | | 'Rainbow Effect' | Rainbow effect |
| | | | 0...5 Effect off |
| | | | 6...21 Rainbow effect 1 |
| | | | 22...37 Rainbow effect 2 |
| | | | 38...53 Fading green-orange |
| | | | 54...69 Pulse rod-orange |
| | | | 70...85 Pulse blue-white |
| | | | 86...101 Fading blue-yellow |
| | | | 102...117 Rainbow effect 7 |
| | | | 118...133 Rainbow effect 8 |
| | | | 134...149 Rainbow effect 9 |
| | | | 150...165 Rainbow effect 10 |
| | | | 166...181 Rainbow effect 11 |

| Main menu | Menu level 2 | Menu level 3 | Menu level 4 | | |
|------------|----------------|--------------------|---|-------------------------------------|--|
| Meaning | | | | | |
| | | | 182...197 | Rainbow effect 12 | |
| | | | 198...213 | Rainbow effect 13 | |
| | | | 214...229 | Rainbow effect 14 | |
| | | | 230...255 | Rainbow effect 15 | |
| | | 'Auto' | Automatic show | | |
| | | | 0...5 | No automatic show | |
| | | | 6...30 | Automatic show 1 | |
| | | | 31...55 | Automatic show 2 | |
| | | | 56...80 | Automatic show 3 | |
| | | | 81...105 | Automatic show 4 | |
| | | | 106...130 | Automatic show 5 | |
| | | | 131...155 | Automatic show 6 | |
| | | | 156...180 | Automatic show 7 | |
| | | | 181...205 | Automatic show 8 | |
| | | | 206...230 | Automatic show 9 | |
| | 231...255 | Automatic show 10 | | | |
| | 'Speed' | 0...255 | Running speed auto- matic show, increasing | | |
| | | 'Auto Fade' | 0...255 | Fade speed for auto- matic shows | |
| | 'Colour Macro' | Pre-defined colour | | | |
| | | 'Red' | Red | | |
| | | 'Amber' | Amber | | |
| | | 'Yellow Warm' | Yellowish-amber coloured | | |
| | | 'Yellow' | Yellow | | |
| | | 'Green' | Green | | |
| | | 'Turquoise' | Turquoise | | |
| | | 'Cyan' | Cyan | | |
| | | 'Blue' | Blue | | |
| 'Lavender' | | Lavender | | | |
| 'Mauve' | | Mauve | | | |
| 'Magenta' | | Magenta | | | |

| Main menu | Menu level 2 | Menu level 3 | Menu level 4 | |
|----------------|---------------------------------------|--|---|------------------|
| | Meaning | | | |
| | | 'Pink' | Pink | |
| | | 'Warm White' | Warm white | |
| | | 'Colour Macro' | Colour macro | |
| | | 'White' | White | |
| | | 'Cold White' | Cold white | |
| 'Settings' | 'Display Rev' | Display inversion | | |
| | | 'ON' | On, display is rotated by 180° | |
| | | 'OFF' | Off, normal display | |
| | 'Display' | Automatic display shutdown when not in use | | |
| | | 'ON' | Enabled | |
| | | 'OFF' | Disabled | |
| | 'DMX Fail' | Device behaviour on DMX signal failure | | |
| | | 'Hold' | Retaining last settings | |
| | | 'Blackout' | Blackout | |
| | 'Dimmer Curve' | Dimmer curve | | |
| | | 'Linear' | Linear | |
| | | 'Exp' | Exponential | |
| | | 'Log' | Logarithmic | |
| | | 'S Curve' | S-shaped | |
| | 'Dimmer Response' | Dimmer characteristic | | |
| | | 'LED' | Dimmer characteristic 'LED' (3 s delay) | |
| | | 'Halogen' | Dimmer characteristic 'Halogen' (5 s delay) | |
| | 'White Balance' | White balance | | |
| | | 'Red' | 0...255 | Red proportion |
| | | 'Green' | 0...255 | Green proportion |
| | | 'Blue' | 0...255 | Blue proportion |
| | | 'White' | 0...255 | White proportion |
| | 'Fan Set' | Fan speed | | |
| 'Auto' | | Automatic fan speed control | | |
| 'High' | | Fan speed constantly high | | |
| 'Wireless DMX' | Resetting the wireless DMX connection | | | |

| Main menu | Menu level 2 | Menu level 3 | Menu level 4 |
|---------------|-----------------|-------------------------------------|--|
| | Meaning | | |
| | | 'Reset Wireless DMX Memory' | 'No' The wireless DMX connection is not getting reset |
| | | | 'Yes' The wireless DMX connection is getting reset |
| | 'Test' | Automatic self test | |
| | | 'OFF' | Turned off |
| | | 'ON' | On |
| | 'Factory Reset' | Reset to factory defaults | |
| | | 'OFF' | Turned off |
| | | 'ON' | Starting |
| | 'Keylock' | Key lock | |
| | | 'OFF' | Turned off |
| | | 'ON' | Enabled To unlock the keys, press successively [ENTER], [UP], [DOWN], [UP], [DOWN] and [ENTER]. |
| 'System Info' | 'Firmware' | Show firmware version of the device | |
| | 'Temperature' | 'LED Temp' | Show device temperature |
| | | 'Temp Unit' | Unit selection for device temperature |
| | | | 'Celsius' |
| | | | 'Fahrenheit' |
| | 'Time info' | Operating hours display | |
| | | 'Power on' | Total operating hours |
| | | 'Last run hrs' | Operating hours since last power up |

7.2.1 Operating mode 'DMX'

In DMX mode, the display shows the set DMX mode in its top row and the DMX start address set in the lower part. The display flashes if no DMX signal is received.

7.2.2 Operating mode 'Slave'

In Slave mode, the display shows in the lower part '*Operating Mode: SLAVE*'. The display flashes if no control signal is received.

7.2.3 Operating mode 'Stand-alone'

In Stand-alone mode, the display in its lower part shows how the device is currently set:

- 'Operating Mode: AUTO Fading': Automatic Fade effect
- 'Operating Mode: AUTO Jumping': Automatic Jump effect
- 'Operating Mode: STATIC': Freely mixable colour with optional rainbow and stroboscopic effect or automatic show
- 'Operating Mode: Color Macro': Selecting a pre-defined colour macro

7.3 Menu overview

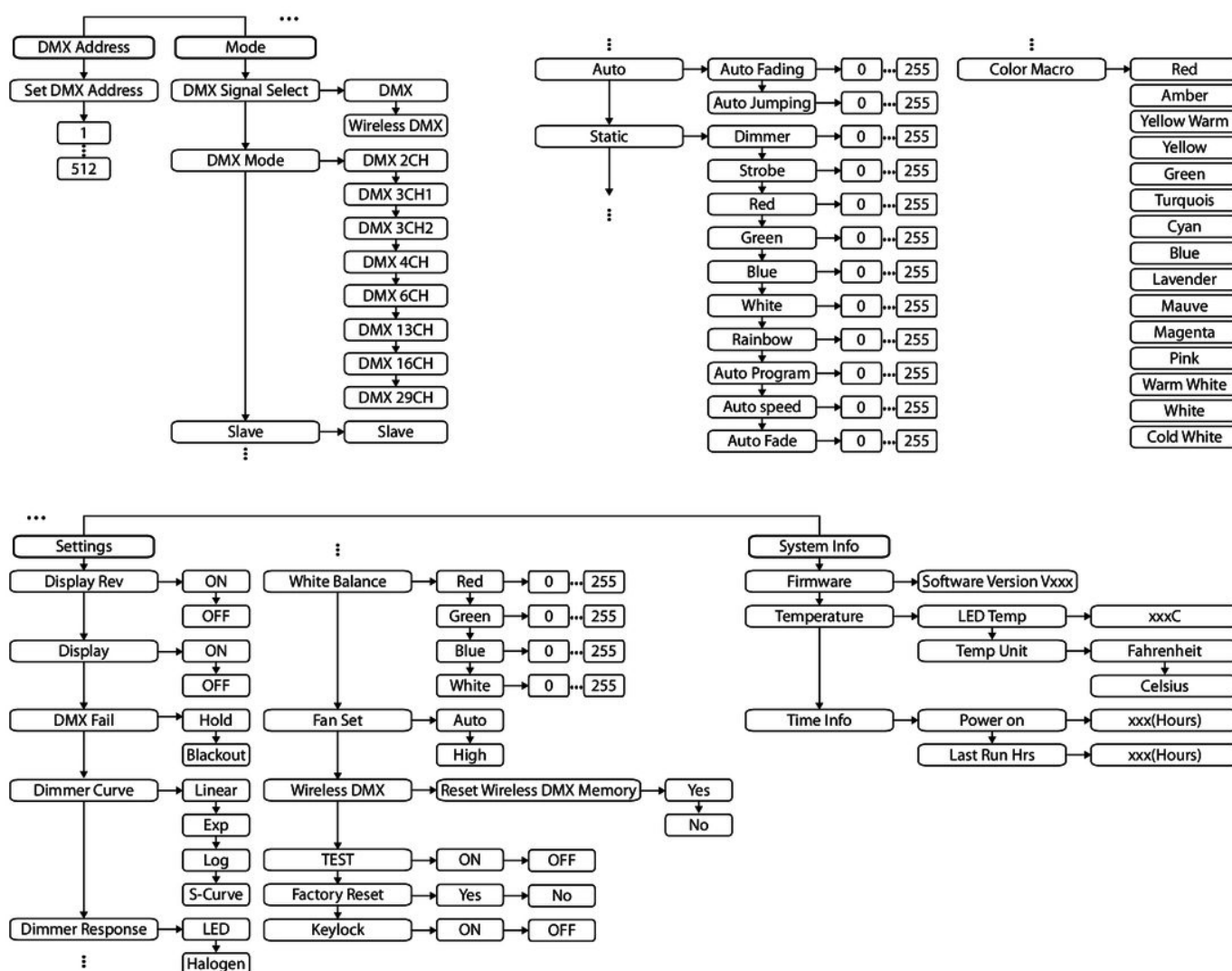

7.4 Functions in 2-channel DMX mode

| Channel | Value | Function |
|-----------|--|--------------------------|
| 1 | 0...255 | Dimmer (0 % to 100 %) |
| 2 | Colour macro | |
| | 0...5 | Blackout |
| | 6...13 | Red |
| | 14...21 | Amber |
| | 22...29 | Yellowish-amber coloured |
| | 30...37 | Yellow |
| | 38...45 | Green |
| | 46...53 | Turquoise |
| | 54...61 | Cyan |
| | 62...69 | Blue |
| | 70...77 | Lavender |
| | 78...85 | Mauve |
| | 86...93 | Magenta |
| | 94...101 | Pink |
| | 102...109 | Warm white |
| | 110...117 | White |
| | 118...125 | Cold white |
| | 126...127 | Colour change halted |
| 128...191 | Colour change effect, increasing speed | |
| 192...255 | Colour transition effect, increasing speed | |

7.5 Functions in 3-channel DMX mode 1

| Channel | Value | Function |
|---------|-----------------------|-------------------------------------|
| 1 | 0...255 | Dimmer (0 % to 100 %) |
| 2 | Stroboscope functions | |
| | 0...5 | Open strobe |
| | 6...10 | Closed strobe |
| | 11...250 | Strobe effect with increasing speed |

| Channel | Value | Function |
|-----------|--|--------------------------|
| | 251...255 | Open strobe |
| 3 | Colour macro | |
| | 0...5 | Blackout |
| | 6...13 | Red |
| | 14...21 | Amber |
| | 22...29 | Yellowish-amber coloured |
| | 30...37 | Yellow |
| | 38...45 | Green |
| | 46...53 | Turquoise |
| | 54...61 | Cyan |
| | 62...69 | Blue |
| | 70...77 | Lavender |
| | 78...85 | Mauve |
| | 86...93 | Magenta |
| | 94...101 | Pink |
| | 102...109 | Warm white |
| | 110...117 | White |
| | 118...125 | Cold white |
| | 126...127 | No function |
| 128...191 | Colour change effect, increasing speed | |
| 192...255 | Colour transition effect, increasing speed | |

7.6 Functions in 3-channel DMX mode 2

| Channel | Value | Function |
|---------|---------|--------------------------------|
| 1 | 0...255 | Intensity red (0 % to 100 %) |
| 2 | 0...255 | Intensity green (0 % to 100 %) |
| 3 | 0...255 | Intensity blue (0 % to 100 %) |

7.7 Functions in 4-channel DMX mode

| Channel | Value | Function |
|---------|---------|--------------------------------|
| 1 | 0...255 | Intensity red (0 % to 100 %) |
| 2 | 0...255 | Intensity green (0 % to 100 %) |
| 3 | 0...255 | Intensity blue (0 % to 100 %) |
| 4 | 0...255 | Intensity white (0 % to 100 %) |

7.8 Functions in 6-channel DMX mode

| Channel | Value | Function |
|---------|-----------------------|-------------------------------------|
| 1 | 0...255 | Dimmer (0 % to 100 %) |
| 2 | Stroboscope functions | |
| | 0...5 | Open strobe |
| | 6...10 | Closed strobe |
| | 11...250 | Strobe effect with increasing speed |
| | 251...255 | Open strobe |
| 3 | 0...255 | Intensity red (0 % to 100 %) |
| 4 | 0...255 | Intensity green (0 % to 100 %) |
| 5 | 0...255 | Intensity blue (0 % to 100 %) |
| 6 | 0...255 | Intensity white (0 % to 100 %) |

7.9 Functions in 13-channel DMX mode

| Channel | Value | Function |
|---------|-----------------------|---|
| 1 | 0...255 | Dimmer (0 % to 100 %) |
| 2 | Stroboscope functions | |
| | 0...5 | Open strobe |
| | 6...10 | Closed strobe |
| | 11...33 | Random Pulse effect with increasing speed |
| | 34...56 | Ramp-up effect with increasing speed |
| | 57...79 | Random Ramp-down effect with increasing speed |

| Channel | Value | Function |
|-----------|--|---|
| | 80...102 | Random strobe effect with increasing speed |
| | 103...127 | Strobe-burst effect with decreasing duration of interruptions |
| | 128...250 | Strobe effect with increasing speed |
| | 251...255 | Open strobe |
| 3 | 0...255 | Intensity red (0 % to 100 %) |
| 4 | 0...255 | Intensity green (0 % to 100 %) |
| 5 | 0...255 | Intensity blue (0 % to 100 %) |
| 6 | 0...255 | Intensity white (0 % to 100 %) |
| 7 | Colour macro | |
| | 0...5 | Blackout |
| | 6...13 | Red |
| | 14...21 | Amber |
| | 22...29 | Yellowish-amber coloured |
| | 30...37 | Yellow |
| | 38...45 | Green |
| | 46...53 | Turquoise |
| | 54...61 | Cyan |
| | 62...69 | Blue |
| | 70...77 | Lavender |
| | 78...85 | Mauve |
| | 86...93 | Magenta |
| | 94...101 | Pink |
| | 102...109 | Warm white |
| | 110...117 | White |
| | 118...125 | Cold white |
| | 126...127 | No function |
| | 128...191 | Colour change effect, increasing speed |
| 192...255 | Colour transition effect, increasing speed | |
| 8 | Rainbow effect | |
| | 0...5 | Effect off |
| | 6...21 | Rainbow effect 1 |
| | 22...37 | Rainbow effect 2 |

| Channel | Value | Function |
|-----------|-------------------|--|
| | 38...53 | Fading green-orange |
| | 54...69 | Pulse rod-orange |
| | 70...85 | Pulse blue-white |
| | 86...101 | Fading blue-yellow |
| | 102...117 | Rainbow effect 7 |
| | 118...133 | Rainbow effect 8 |
| | 134...149 | Rainbow effect 9 |
| | 150...165 | Rainbow effect 10 |
| | 166...181 | Rainbow effect 11 |
| | 182...197 | Rainbow effect 12 |
| | 198...213 | Rainbow effect 13 |
| | 214...229 | Rainbow effect 14 |
| | 230...255 | Rainbow effect 15 |
| 9 | Automatic show | |
| | 0...5 | No automatic show |
| | 6...30 | Automatic show 1 |
| | 31...55 | Automatic show 2 |
| | 56...80 | Automatic show 3 |
| | 81...105 | Automatic show 4 |
| | 106...130 | Automatic show 5 |
| | 131...155 | Automatic show 6 |
| | 156...180 | Automatic show 7 |
| | 181...205 | Automatic show 8 |
| | 206...230 | Automatic show 9 |
| 231...255 | Automatic show 10 | |
| 10 | 0...255 | Running speed automatic show, increasing |
| 11 | 0...255 | Automatic Fade effect |
| 12 | Dimmer curve | |
| | 0...5 | No function |
| | 6...63 | Linear |
| | 64...127 | Exponential |
| | 128...191 | Logarithmic |

| Channel | Value | Function |
|---------|--|---|
| | 192...255 | S-shaped |
| 13 | Special functions. Settings are enabled or retained if the corresponding DMX value is held for five seconds. | |
| | 0...5 | No function |
| | 6...63 | Dimmer characteristic 'LED' (3 s delay) |
| | 64...127 | Dimmer characteristic 'Halogen' (5 s delay) |
| | 128...191 | Fan speed constantly high |
| | 192...255 | Automatic fan speed control |

7.10 Functions in 16-channel DMX mode

| Channel | Value | Function |
|---------|---------|---|
| 1 | 0...255 | Intensity red (0 % to 100 %), LED row 1 |
| 2 | 0...255 | Intensity green (0 % to 100 %), LED row 1 |
| 3 | 0...255 | Intensity blue (0 % to 100 %), LED row 1 |
| 4 | 0...255 | Intensity white (0 % to 100 %), LED row 1 |
| 5 | 0...255 | Intensity red (0 % to 100 %), LED row 2 |
| 6 | 0...255 | Intensity green (0 % to 100 %), LED row 2 |
| 7 | 0...255 | Intensity blue (0 % to 100 %), LED row 2 |
| 8 | 0...255 | Intensity white (0 % to 100 %), LED row 2 |
| 9 | 0...255 | Intensity red (0 % to 100 %), LED row 3 |
| 10 | 0...255 | Intensity green (0 % to 100 %), LED row 3 |
| 11 | 0...255 | Intensity blue (0 % to 100 %), LED row 3 |
| 12 | 0...255 | Intensity white (0 % to 100 %), LED row 3 |
| 13 | 0...255 | Intensity red (0 % to 100 %), LED row 4 |
| 14 | 0...255 | Intensity green (0 % to 100 %), LED row 4 |
| 15 | 0...255 | Intensity blue (0 % to 100 %), LED row 4 |
| 16 | 0...255 | Intensity white (0 % to 100 %), LED row 4 |

7.11 Functions in 29-channel DMX mode

| Channel | Value | Function |
|-----------|-----------------------|---|
| 1 | 0...255 | Dimmer (0 % to 100 %) |
| 2 | Stroboscope functions | |
| | 0...5 | Open strobe |
| | 6...10 | Closed strobe |
| | 11...33 | Random Pulse effect with increasing speed |
| | 34...56 | Ramp-up effect with increasing speed |
| | 57...79 | Random Ramp-down effect with increasing speed |
| | 80...102 | Random strobe effect with increasing speed |
| | 103...127 | Strobe-burst effect with decreasing duration of interruptions |
| | 128...250 | Strobe effect with increasing speed |
| | 251...255 | Open strobe |
| 3 | 0...255 | Intensity red (0 % to 100 %) |
| 4 | 0...255 | Intensity green (0 % to 100 %) |
| 5 | 0...255 | Intensity blue (0 % to 100 %) |
| 6 | 0...255 | Intensity white (0 % to 100 %) |
| 7 | Colour macro | |
| | 0...5 | Blackout |
| | 6...13 | Red |
| | 14...21 | Amber |
| | 22...29 | Yellowish-amber coloured |
| | 30...37 | Yellow |
| | 38...45 | Green |
| | 46...53 | Turquoise |
| | 54...61 | Cyan |
| | 62...69 | Blue |
| | 70...77 | Lavender |
| | 78...85 | Mauve |
| | 86...93 | Magenta |
| | 94...101 | Pink |
| | 102...109 | Warm white |
| 110...117 | White | |

| Channel | Value | Function |
|-----------|-------------------|--|
| | 118...125 | Cold white |
| | 126...127 | No function |
| | 128...191 | Colour change effect, increasing speed |
| | 192...255 | Colour transition effect, increasing speed |
| 8 | Rainbow effect | |
| | 0...5 | Effect off |
| | 6...21 | Rainbow effect 1 |
| | 22...37 | Rainbow effect 2 |
| | 38...53 | Fading green-orange |
| | 54...69 | Pulse rod-orange |
| | 70...85 | Pulse blue-white |
| | 86...101 | Fading blue-yellow |
| | 102...117 | Rainbow effect 7 |
| | 118...133 | Rainbow effect 8 |
| | 134...149 | Rainbow effect 9 |
| | 150...165 | Rainbow effect 10 |
| | 166...181 | Rainbow effect 11 |
| | 182...197 | Rainbow effect 12 |
| | 198...213 | Rainbow effect 13 |
| | 214...229 | Rainbow effect 14 |
| 230...255 | Rainbow effect 15 | |
| 9 | Automatic show | |
| | 0...5 | No automatic show |
| | 6...30 | Automatic show 1 |
| | 31...55 | Automatic show 2 |
| | 56...80 | Automatic show 3 |
| | 81...105 | Automatic show 4 |
| | 106...130 | Automatic show 5 |
| | 131...155 | Automatic show 6 |
| | 156...180 | Automatic show 7 |
| | 181...205 | Automatic show 8 |
| | 206...230 | Automatic show 9 |

| Channel | Value | Function |
|---------|--|---|
| | 231...255 | Automatic show 10 |
| 10 | 0...255 | Running speed automatic show, increasing |
| 11 | 0...255 | Automatic Fade effect |
| 12 | Dimmer curve | |
| | 0...5 | No function |
| | 6...63 | Linear |
| | 64...127 | Exponential |
| | 128...191 | Logarithmic |
| | 192...255 | S-shaped |
| 13 | Special functions. Settings are enabled or retained if the corresponding DMX value is held for five seconds. | |
| | 0...5 | No function |
| | 6...63 | Dimmer characteristic 'LED' (3 s delay) |
| | 64...127 | Dimmer characteristic 'Halogen' (5 s delay) |
| | 128...191 | Fan speed constantly high |
| | 192...255 | Automatic fan speed control |
| 14 | 0...255 | Intensity red (0 % to 100 %), LED row 1 |
| 15 | 0...255 | Intensity green (0 % to 100 %), LED row 1 |
| 16 | 0...255 | Intensity blue (0 % to 100 %), LED row 1 |
| 17 | 0...255 | Intensity white (0 % to 100 %), LED row 1 |
| 18 | 0...255 | Intensity red (0 % to 100 %), LED row 2 |
| 19 | 0...255 | Intensity green (0 % to 100 %), LED row 2 |
| 20 | 0...255 | Intensity blue (0 % to 100 %), LED row 2 |
| 21 | 0...255 | Intensity white (0 % to 100 %), LED row 2 |
| 22 | 0...255 | Intensity red (0 % to 100 %), LED row 3 |
| 23 | 0...255 | Intensity green (0 % to 100 %), LED row 3 |
| 24 | 0...255 | Intensity blue (0 % to 100 %), LED row 3 |
| 25 | 0...255 | Intensity white (0 % to 100 %), LED row 3 |
| 26 | 0...255 | Intensity red (0 % to 100 %), LED row 4 |
| 27 | 0...255 | Intensity green (0 % to 100 %), LED row 4 |
| 28 | 0...255 | Intensity blue (0 % to 100 %), LED row 4 |
| 29 | 0...255 | Intensity white (0 % to 100 %), LED row 4 |

8 Technical specifications

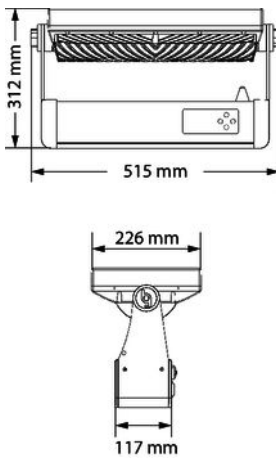

| | | |
|------------------------|---|---|
| Light source | 36 × RGBW LED, each 15 W | |
| Optical properties | Beam angle | 25° (with filter 40°) |
| Control | DMX | |
| | W-DMX | |
| | Buttons and display on the unit | |
| Number of DMX channels | 2, 3, 4, 6, 13, 16 or 29 | |
| Input connections | Power supply | Power Twist IP65 |
| | DMX control | XLR chassis plug, 3-pin, IP65 version |
| Output connections | Power supply | Power Twist IP65 |
| | DMX control | XLR chassis socket, 3-pin, IP65 version |
| Power consumption | 500 W | |
| Supply voltage | 100 – 240 V ~ 50/60 Hz | |
| Degree of protection | IP65 | |
| Mounting options | hanging, standing | |
| | Omega bracket | |
| Dimensions (W × H × D) | 515 mm × 312 mm × 226 mm (panel horizontal) | |
| Weight | 13.3 kg | |
| Ambient conditions | Temperature range | –20 °C ... +40 °C |
| | Relative humidity | 50 %, non-condensing |

Further information

| | |
|-----------------------|--------------|
| Outdoor housing shape | Flood light |
| Colour mixture | RGBW |
| LED type | x-in-1 |
| Floor housing | Yes |
| Fanless | No |
| Remote control | Not possible |
| Wireless DMX | Yes |
| Housing colour | black |

9 Plug and connection assignments

Introduction

This chapter will help you select the right cables and plugs to connect your valuable equipment so that a perfect light experience is guaranteed.

Please take our tips, because especially in 'Sound & Light' caution is indicated: Even if a plug fits into a socket, the result of an incorrect connection may be a destroyed DMX controller, a short circuit or 'just' a not working light show!

DMX connections

The unit offers a 3-pin XLR socket for DMX output and a 3-pin XLR plug for DMX input. Please refer to the drawing and table below for the pin assignment of a suitable XLR plug.



| Pin | Configuration |
|-----|---------------------------------------|
| 1 | Ground, shielding |
| 2 | Signal inverted (DMX-, 'cold signal') |
| 3 | Signal (DMX+, 'hot signal') |

10 Troubleshooting

In the following we list a few common problems that may occur during operation. We give you some suggestions for easy troubleshooting:

| Symptom | Remedy |
|---|---|
| The unit does not work, no light | Check the mains connection and main fuse. |
| One colour does not work or the colours differ when using multiple lamps. | Check the settings in the 'White Balance' menu. If the function is missing, values may be set to '000'. If the colour rendering is different, set all values for the colours in the 'White Balance' menu to '255'. You can then fine-tune the colour rendering. |
| No response to the DMX controller | <ol style="list-style-type: none"> 1. Check the DMX connectors and cables for proper connection. 2. Try using another DMX controller. 3. Check whether the DMX cables run near or parallel to high-voltage cables that may cause damage or interference to a DMX interface circuit. 4. Press Mode until the display shows 'ADDRESS XXX'. 5. Check whether 'DMX' (with wired connection) is selected in the 'DMX Signal Select' menu. |
| The devices do not connect to the W-DMX transmitter or do not response to the W-DMX signal. | Check whether 'Wireless DMX' is selected in the 'DMX Signal Select' menu. Reset the connection by performing a reset in the 'Reset Wireless DMX Memory' menu. The devices must then be reassigned to the transmitter by pressing the [Link] button on the transmitter. |
| The device does not respond or only with a delay to the W-DMX signal. | Check the transmission mode of the W-DMX transmitter. Test the connection with the G5, G4S or G3 mode (if possible). Please note that the W-DMX must be reset on all devices after changing the transmitter. |

If the procedures recommended above do not succeed, please contact our Service Center. You can find the contact information at www.thomann.de.

11 Cleaning

Optical lenses

Clean the optical lenses, that are accessible from the outside, regularly in order to optimize the light output. The frequency of cleaning depends on the operating environment: wet, smoky or particularly dirty surroundings can cause more accumulation of dirt on the optics of the device.

- Clean with a soft cloth using our lamp and lens cleaner (item no. 280122).
- Always dry the parts carefully.

12 Protecting the environment

Disposal of the packaging material



For the transport and protective packaging, environmentally friendly materials have been chosen that can be supplied to normal recycling.

Ensure that plastic bags, packaging, etc. are properly disposed of.

Do not just dispose of these materials with your normal household waste, but make sure that they are collected for recycling. Please follow the notes and markings on the packaging.

Disposal of your old device



This product is subject to the European Waste Electrical and Electronic Equipment Directive (WEEE) in its currently valid version. Do not dispose with your normal household waste.

Dispose of this device through an approved waste disposal firm or through your local waste facility. When discarding the device, comply with the rules and regulations that apply in your country. If in doubt, consult your local waste disposal facility.

