

Instruction Manual

impression[&]
X4



from software version: 1.18/18/12/10/n
Rev. B



e-mail: service@glp.de
Internet: <http://www.glp.de>

Table of contents

1	Description of Device.....	4
1.1	Safety Instructions	5
2	Preparation and Installation	6
2.1	Safety information.....	6
2.2	Mounting.....	7
2.2.1	<i>Mounting on the Floor (Upright)</i>	8
2.2.2	<i>Mounting in hanging position</i>	8
2.2.3	<i>Mounting in sideways Position</i>	9
2.3	Securing the Fixture.....	9
2.4	Connections.....	10
2.4.1	<i>Power Supply</i>	10
2.4.2	<i>DMX</i>	10
3	The Menu Field	10
4	DMX Channel Selection (DMX Protocol)	13
5	Maintaining and Cleaning the IMPRESSION X4.....	18
5.1	Safety regulations	18
5.2	Maintenance and Interval (rule-of-thumb).....	18
6	Technical Specifications	19
7	Dimensions.....	20
8	Index.....	21
9	Pattern	Fehler! Textmarke nicht definiert.

1 Description of Device

- 1. Moving head (actively and passively cooled)
- 2. Arm with various cooling vents
- 3. LCD-Display/Menu (data entry)
- 4. Base with various connectors and Camlock mounting system

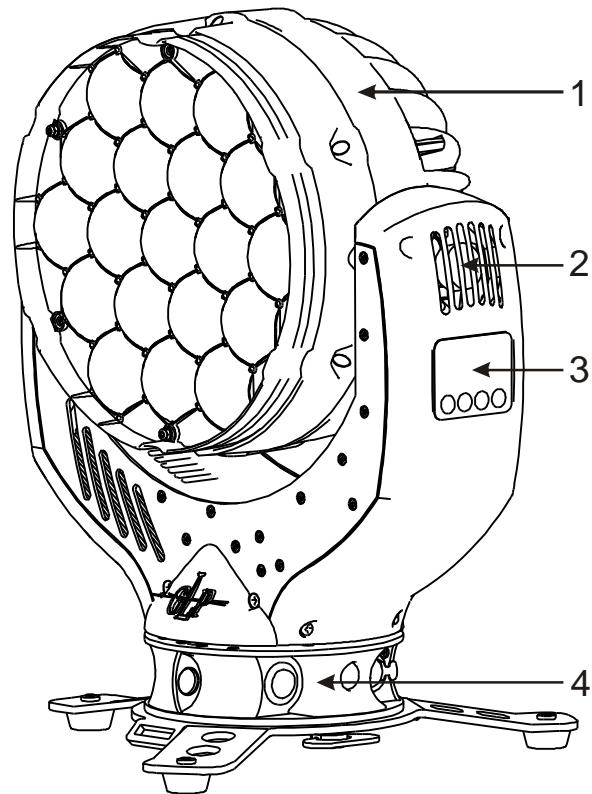

Base side 1

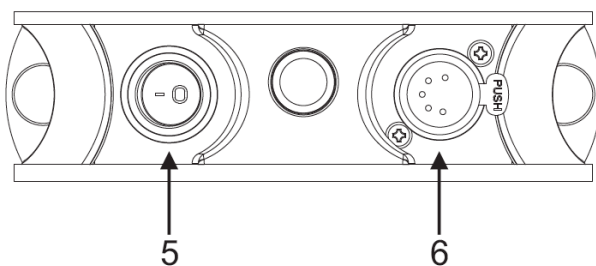

- 5. Power On/Off
- 6. DMX- Output (5 pin)
- 7. DMX- Input (5 pin)
- 8. Micro-fuse 5x20mm, T5A
- 9. Mains supply (Powercon)
- 10. 2 x Safety eyes

Base side 2

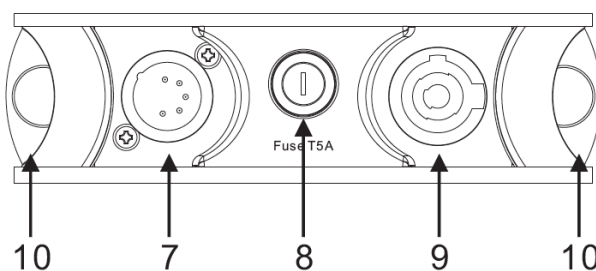

1.1 Safety Instructions



The **IMPRESSION X4** is a High-Tech Product. To guarantee a smooth operation, it is necessary to respect the following rules.

The manufacturer of this device will not take responsibility for damages through any disregard of the information provided in this manual. Warranty claims also will be voided in the case that the fixture housing is opened.

1. Before powering on the fixture, make sure that the fixtures fans and air inlets are clean and not blocked.
2. Ensure that the fixture head can rotate unhindered throughout its complete range of pan and tilt movement. A safety distance of at least 0.5 m must be maintained between the fixture and any easily inflammable material (e.g. decoration material).
3. **Attention!** Don't touch the fixture during the operation. This can cause injuries and/or damages.
4. **The fixture doesn't contain any user serviceable parts. Opening the fixture will void all warranties.**
5. It is necessary to wait at least 15 minutes after disconnecting the mains power before handling the fixture.. Pay attention to possible hot parts of the fixture.
-- Danger of BURNING --
6. **Never look directly into the beam of light or into one of the LEDs.** Never use optical apertures to observe the beam of light. **LED Class 2M.** You'll risk serious injury of your eyes and in particular of your retina.



Attention: LED Class 2M can cause injuries of your eyes even without optical instruments in front of them or within a distance of less than 0.5m and short exposure time.

Hence: Avoid direct radiation into your eyes!

7. To ensure safe operation, follow also the Installation guide described in chapter 2. Operating the **IMPRESSION X4** without suitable safety aids like Safety cables or clamps/hooks can increase the risk of an accident and must be avoided.
8. Repair, maintenance, and installation work shall be done by qualified or GLP certified staff only. You need to pay attention to the common rules of technology that are not explicitly mentioned in this manual.
9. Use only original GLP spare parts. Any structural modification of the system will terminate all warranty claims.
10. Please keep this instruction manual for future reference.

2 Preparation and Installation

2.1 Safety information

The **IMPRESSION X4** fixtures from GLP is fitted with a number of plano-convex lenses in a highly efficient collimator cluster. This type of lens can act as a strong magnifying glass.

If the rays from a strong light source (such as the sun or another lighting fixture) are directed towards the front of any of these fixtures, then internal damage may occur. In a worst case scenario with a high power light source this can happen very quickly, damaging the fixture internally, potentially melting components or causing an internal fire within seconds.

In order to avoid these possible problems please adhere to the following requirements:

- Do not expose the front of a fixture to direct sunlight or any other strong light sources.
- For outdoor applications during daylight make sure that the front face of any fixture is either shielded or points away from the sun, even when fixtures are not in use.
- Do not modify the front glass or lenses of any fixture.

These requirements have to be followed regardless of whether a fixture is powered on or off as the magnifying effect is an optical effect and therefore independent from the (electrical) state of the fixture.

Especially when working with high powered **beam-lights**; extreme caution and observance of these safety instructions is mandatory.

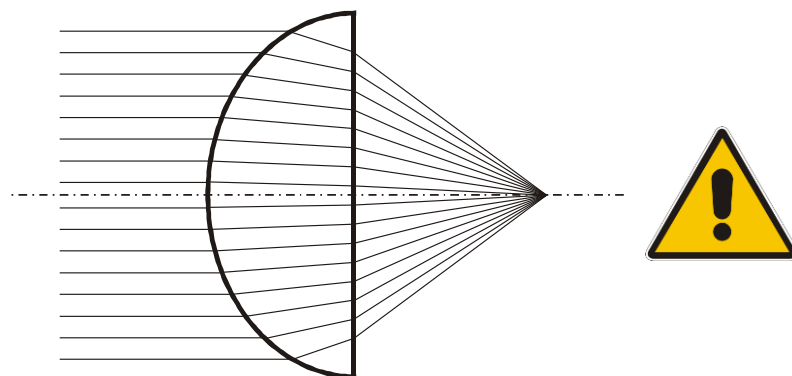

Should you have any questions about the operation of your fixture then please contact your local GLP office, or their authorized distributor, a list of which can be found at <http://www.glp.de>.

2.2 Mounting

The **IMPRESSION X4** is fully operational whether it hangs or is mounted to the wall. It can also be operated while standing on the floor. Keep a safety distance of min. 0.5 m towards any easily inflammable materials (decoration etc.).

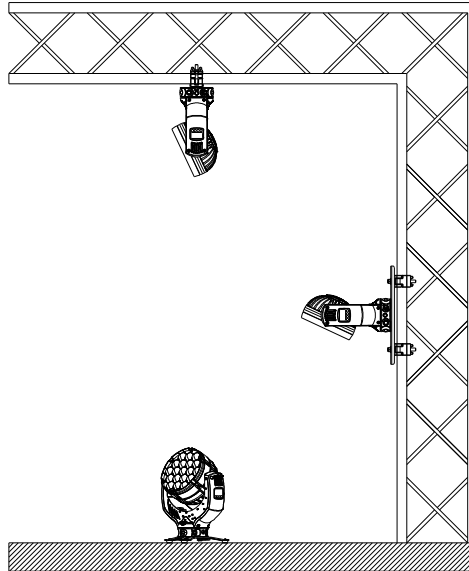

Pay attention to the regulations of: **BGV C1 (former VBG 70)** and **DIN VDE 0711-217**.

The installation shall be done by qualified staff only.

For the various mounting positions of the **IMPRESSION X4** (standing on the floor, sideways or hanging) different accessories kits are available. Through this a safe and firm installation is assured. You'll find dedicated connectors on the bottom side of the fixture which should be used. In addition the base is marked with a **FRONT** arrow allowing consistent orientation during installation.

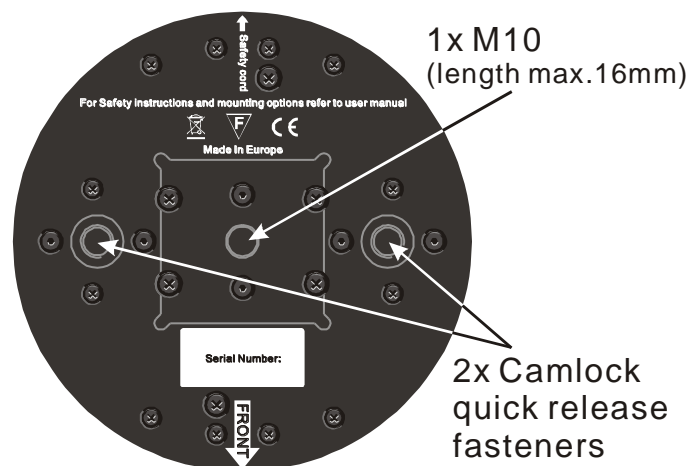

front side of the fixture

2.2.1 Mounting on the Floor (Upright)

To operate the **IMPRESSION X4** in an upright position, please use the dedicated tri-legged floor stand supplied with your fixture. It is fixed to the base of the fixture with fasteners called Camlock quick-release connectors. Insert the two fasteners and turn each 90° to lock them. Do the opposite to release them again. On both sides you'll find eyelets to pull through a fixing strap. This allows for additional bracing of the fixture.

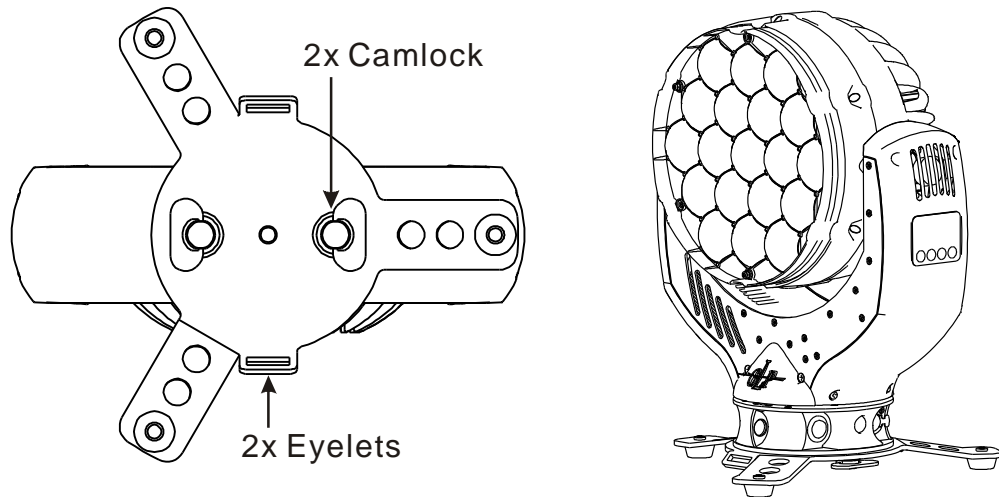

2.2.2 Mounting in hanging position

To operate the **IMPRESSION X4** in a hanging position please use a half-coupler (clamp). This can be mounted directly to the bottom side of the fixture. It should be attached centrally with a M10x16 mm thread bolt.

Attention: Never use a longer bolt as this may damage the interior of the fixture.

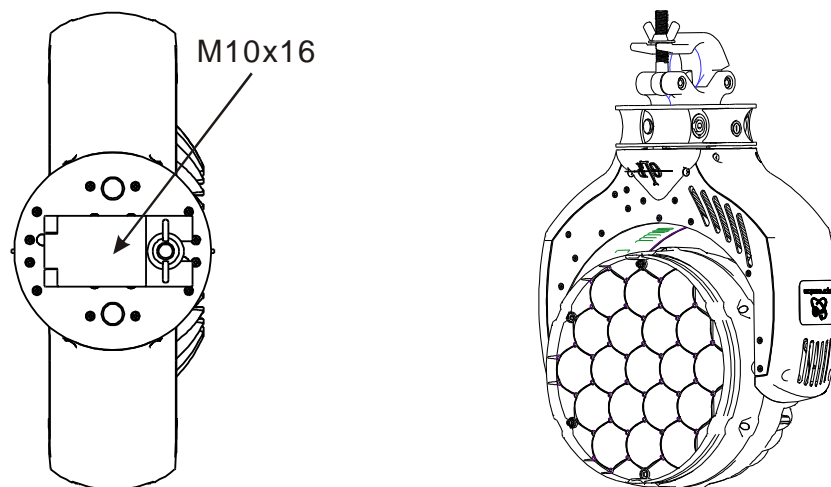

2.2.3 Mounting in sideways Position

To operate the **IMPRESSION X4** in a sideways position please use an additional mounting bar. This is fixed by two Camlock quick-release connectors. Two half-couplers (clamps) are used to mount the bar to a standard truss bar. This technique is necessary to cope with the torque which accrues in this mounting position. In addition it allows a re-positioning of the couplers to fit between two truss chords. Never use the "Mounting in hanging position" technique described above to fasten the fixture in the sideways position. A safe and sound installation can not be assured in this way. In addition this can damage the fixture base.

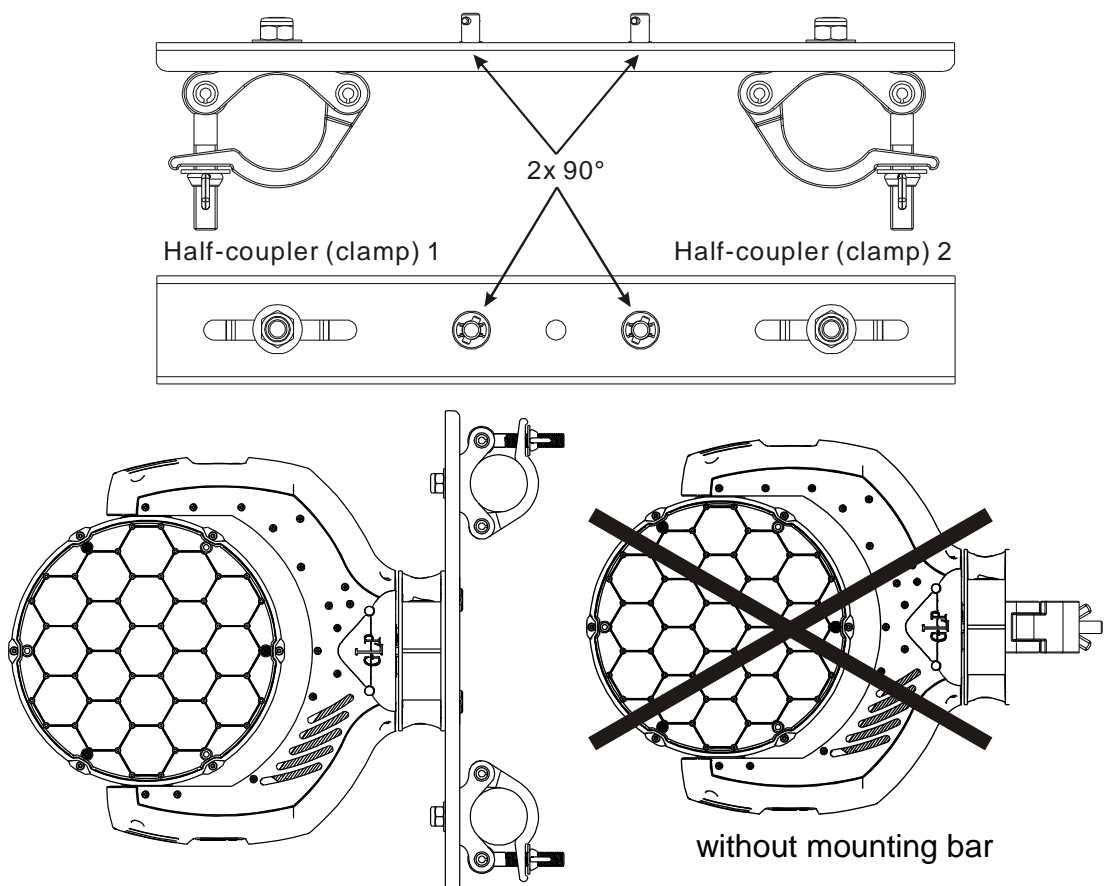

2.3 Securing the Fixture

Regardless of the mounting method of the **IMPRESSION X4** you'll have to use a stipulated safety wire. Attach the safety wire through one of the two holes provided on the base of the fixture and connect it to the primary support structure. Pay attention to a safe and proper fastening. The safety cable must comply with EN 60598-2-17 Section 17.6.6 and be capable of bearing a static suspended load that is ten times the weight of the fixture and all installed accessories.

2.4 Connections

2.4.1 Power Supply

~100-240 Volt AC, 50-60 Hz, earth contact type plug - Powercon

Connected load 350 VA (W) \Leftrightarrow T5A (micro-fuse 5x20mm)

Please see printing on the case for the right electronic supply!

Disconnect from the mains supply for changing the fuse and use only the above described micro-fuse type.

2.4.2 DMX

USITT DMX-512 Standard input/output in 5 pin connectors.

Pin 1 = [Ground] / Pin 2 = [-] / Pin 3 = [+] / Pin 4&5 N.C.

The DMX- Addressing starts at the DMX- Address [001].

3 The Menu Field

You'll find the control board on the side part of the arm. It allows you to make all necessary adjustments of the **IMPRESSION X4**. With the **Mode**-key you get into the main menu. Afterwards you can navigate through the menu with the **Up/Down**-keys. Push the **Enter**-key to get in the next menu level or to confirm your settings. Make them and set functions **ON/OFF** with the **Up/Down**-keys. Confirm and save it with the **Enter**-key (the display shows **OK**). Push the **Mode**-key to cancel the entry and go back to the main menu.

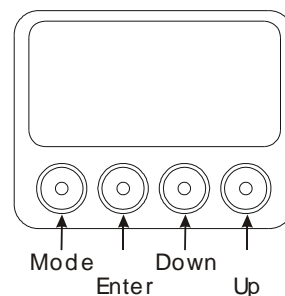

To lock or unlock the keys of the menu field press Mode+Enter+Up simultaneously.

← MODE - ENTER →

Level1	Level 2	Level 3	Level 4	Remark
DMX Start Address 001				Set the DMX start address
Special	Manual DMX			Manual control of all fixture functions
		Pan		Manual control for Pan (X-movement)
		Pattern Byte 3		Manual control for Pattern Byte 3 LED 17 -19
		Pattern Byte 2		Manual control for Pattern Byte 2 LED 9 - 16
		Pattern Byte 1		Manual control for Pattern Byte 1 LED 1 - 8
		Pattern		Manual control for Pattern channel / bank
		Zoom		Manual control for Zoom
		Speed Movements		Manual control for Pan/Tilt movements

← DOWN - UP →

	Pan/Tilt Movements	Manual control for Pan/Tilt movements
	Special	
	White Temperature	Manual control for Color temperature
	Dimmer	Manual control for Dimmer
	Shutter	Manual control for Shutter
	White	Manual control for White
	Blue	Manual control for blue
	Green	Manual control for green
	Red	Manual control for red
	Color Wheel	Manual control for the color wheel
	Tilt	Manual control for Tilt (Y-movement)
Adjust	Key code xxxx	Use the code for entering the calibration menu (for authorized persons only)
	Display Contrast	Adjustment for the Display contrast
	PWM - Frequ. Adj.	Changes PMW frequency
	Pan Offset	Calibration for Pan-Offset
	Tilt Offset	Calibration for Tilt-Offset
	LED adjust	
	White adjust red	Adjust intensity for red channel
	White adjust blue	Adjust intensity for blue channel
	White adjust green	Adjust intensity for green channel
	Clear EEPROM	Erase EEPROM memory
	Diagnose	Diagnose fixture functions
DMX Image	Set image if DMX off	Activates a stored scene if DMX is off
	Save image in memory	Stores the scene currently sent to the unit
DMX input Monitor		Indicates the presently received DMX signal per DMX channel
	Pan	Instantaneous value for Pan
	Tilt	Instantaneous value for Tilt
	Pattern Byte 3	Instantaneous value for Pattern Byte 3
	Pattern Byte 2	Instantaneous value for Pattern Byte 2
	Pattern Byte 1	Instantaneous value for Pattern Byte 1

← DOWN - UP →

	Pattern	Instantaneous value for Pattern channel / bank
	Zoom	Instantaneous value for Zoom
	Speed Movements	Speed adjustment for Pan/Tilt movements → see item below
	Pan/Tilt Movements	Instantaneous value for Pan/Tilt movements
	Special	Instantaneous value for Special
	White Temperature	Adjustment of the color temperature for WHITE
	Dimmer	Instantaneous value for Dimmer
	Shutter	Instantaneous value for Shutter
	White	Instantaneous value for White
	Blue	Instantaneous value for Blue
	Green	Instantaneous value for Green
	Red	Instantaneous value for Red
	Color Wheel	Instantaneous value for Color Mixing unit
Set DMX Mode	Compressed Mode	Select the desired DMX Mode Fixture works in "Compressed" mode → see also section 4 unterhalb
	Normal Mode	Fixture works in "Normal" mode → see also section 4 unterhalb
	High-Res. Mode	Fixture works in "High Resolution" mode → see also section 4 unterhalb
Position feedback		Switch automatic position feedback ON/OFF
Reverse Pan		Invert Pan movements: ON/OFF
Reverse Tilt		Invert Tilt movements: ON/OFF
Reset		RESET and new calibration for all functions

4 DMX Channel Selection (DMX Protocol)

Normal-Mode 20 DMX channels

Channel	Function	Time and Value	DMX	HEX	%
1) PAN-coarse	0 .. 623°	3,2s	0..255	00..FF	0..100
2) PAN-fine			0..255	00..FF	0..100
3) Tilt-coarse	0 .. 295°	1,5s	0..255	00..FF	0..100
4) Tilt-fine			0..255	00..FF	0..100
5) Color (fixed)	Colors adjustable via RGB		0..7	00..07	0..2.5
	Color 01 - Red ¹⁾		8..15	08..0F	3..5.5
	Color 02 - Amber ¹⁾		16..23	10..17	6..8.5
	Color 03 - Warm Yellow ¹⁾		24..31	18..1F	9..12.5
	Color 04 - Yellow ¹⁾		32..39	20..27	13..15.5
	Color 05 - Green ¹⁾		40..47	28..2F	16..18.5
	Color 06 - Turquoise ¹⁾		48..55	30..37	19..21.5
	Color 07 - Cyan ¹⁾		56..63	38..3F	22..24.5
	Color 08 - Blue ¹⁾		64..71	40..47	25..27.5
	Color 09 - Lavender ¹⁾		72..79	48..4F	28..30.5
	Color 10 - Malve ¹⁾		80..87	50..57	31..34.5
	Color 11 - Magenta ¹⁾		88..95	58..5F	35..37.5
	Color 12 - Pink ¹⁾		96..103	60..67	38..40.5
	White - CTO	3200K	104..111	68..6F	41..43.5
	White	5600K	112..119	70..77	44..46.5
	White - CTB	7200K	120..127	78..7F	47..49.5
	Rainbow Effect Stop ²⁾		128	80	50
Rainbow Effect ³⁾	slow - fast	129..223	81..DF	51..88	
Random colors	slow - fast	224..255	E0..FF	89..100	
6) Red	Color mixing system - Red	0 - 100%	0..255	00..FF	0..100
7) Green	Color mixing system - Green	0 - 100%	0..255	00..FF	0..100
8) Blue	Color mixing system - Blue	0 - 100%	0..255	00..FF	0..100
9) White	Color mixing system - White	0 - 100%	0..255	00..FF	0..100
10) Shutter	Shutter closed		0..15	00..0F	0..5.5
	Shutter pulse random	slow – fast	16..47	10..2F	6..18.5
	Up-dimming then Shutter closing (random patterns)	slow – fast	48..79	30..4F	19..31
	Shutter open then down-dimming (random patterns)	slow – fast	80..111	50..6F	32..43
	Up-dimming then down-dimming (random patterns)	slow – fast	112..143	70..8F	44..56
	Strobe effect pause	5s - 0.1s	160..199	A0..C7	63..77
	Strobe effect slow - fast	1 Hz - 10 Hz	200..239	C8..EF	78..94
	Shutter open		240..255	F0..FF	95..100
11) Dimmer	Dimmer	0 - 100%	0..255	0..FF	0..100
12) CTO	No CTO		0..7	0..07	0..2.5
	Continuous color temperature correction	Applicable for ALL colors	8..255	08..FF	3..100
13) Special	Pattern Block 1 → channel 17		0..3	00..03	0..1
	Pattern Block 2 → channel 17		4..7	04..07	1.5..2.5
	Change PWM frequency		100..200	64..C8	40..78
	RESET		250..255	FA..FF	98..100
14) Movement	No macros		0	00	0
	Movement	Size	Phase	Use "Speed" to adjust	

Channel	Function	Time and Value	DMX	HEX	%	
macros	PAN	1	0°	01..01	01..01	0.5
		1	90°	02..03	02..03	1.0
		1	180°	04..05	04..05	1.7
		1	270°	06..07	06..07	2.5
	PAN	2	0°	08..09	08..09	3.3
		2	90°	10..11	0A..0B	4.1
		2	180°	12..13	0C..0D	4.9
		2	270°	14..15	0E..0F	5.7
	PAN	3	0°	16..17	11..11	6.5
		3	90°	18..19	12..13	7.3
		3	180°	20..21	14..15	8.0
		3	270°	22..23	16..17	8.8
	PAN	4	0°	24..25	18..19	9.6
		4	90°	26..27	1A..1B	10.4
		4	180°	28..29	1C..1D	11.2
		4	270°	30..31	1E..1F	12
		TILT	size / phase see PAN	32..63	20..3F	13..25
		PAN / TILT	size / phase see PAN	64..95	40..5F	26..37
		PAN / TILT (inverse)	size / phase see PAN	96..127	60..7F	38..50
		Circle	size / phase see PAN	128..159	80..9F	51..62
	Circle (inverse)	size / phase see PAN	160..191	A0..BF	63..75	
	Lying eight	size / phase see PAN	192..223	C0..DF	76..87	
	Random movement	size / phase see PAN	224..255	E0..FF	88..100	
15) Speed	Pan/Tilt movement speed from controller		0..1	00..01	0..0.5	
Pan/Tilt	Pan/Tilt, slow – fast Use this channel also for the speed of the movements (channel 14).		02..255	02..FF	1..100	
16) Zoom	Wide - narrow (spot)		0...255	00...FF	0...100	
17) Pattern	No pattern		0..2	00..02	0..1	
	250 pre-defined patterns (see appendix A)		03..253	03..FD	2..99	
	Activates direct access to LED Pattern	See channels 18-20	254..255	FE..FF	100	
18) Pattern Byte 1	Direct access to Pattern of LED 1..8		0...255	00...FF	0...100	
19) Pattern Byte 2	Direct access to Pattern of LED 9..16		0...255	00...FF	0...100	
20) Pattern Byte 3	Direct access to Pattern of LED 17..19		0..07	00...07	0..2.5	

Compress-Mode 14 DMX channels

Channel	Function	Time and Value	DMX	HEX	%
1) PAN-coarse	0 .. 623°	3,2s	0..255	00..FF	0..100
2) PAN-fine			0..255	00..FF	0..100
3) Tilt-coarse	0 .. 295°	1,5s	0..255	00..FF	0..100
4) Tilt-fine			0..255	00..FF	0..100
5) Color (fixed)	Colors adjustable via RGB		0..7	00..07	0..2.5
	Color 01 - Red ¹⁾		8..15	08..0F	3..5.5
	Color 02 - Amber ¹⁾		16..23	10..17	6..8.5
	Color 03 - Warm Yellow ¹⁾		24..31	18..1F	9..12.5

Channel	Function	Time and Value	DMX	HEX	%
	Color 04 - Yellow ¹⁾		32..39	20..27	13..15.5
	Color 05 - Green ¹⁾		40..47	28..2F	16..18.5
	Color 06 - Turquoise ¹⁾		48..55	30..37	19..21.5
	Color 07 - Cyan ¹⁾		56..63	38..3F	22..24.5
	Color 08 - Blue ¹⁾		64..71	40..47	25..27.5
	Color 09 - Lavender ¹⁾		72..79	48..4F	28..30.5
	Color 10 - Mauve ¹⁾		80..87	50..57	31..34.5
	Color 11 - Magenta ¹⁾		88..95	58..5F	35..37.5
	Color 12 - Pink ¹⁾		96..103	60..67	38..40.5
	White - CTO	Color temperature 3200K	104..111	68..6F	41..43.5
	White	Color temperature 5600K	112..119	70..77	44..46.5
	White - CTB	Color temperature 7200K	120..127	78..7F	47..49.5
	Rainbow Effect Stop ²⁾		128	80	50
	Rainbow Effect ³⁾	slow - fast	129..223	81..DF	51..88
	Rainbow Effect, random colors	slow - fast	224..255	E0..FF	89..100
6) Red	Color mixing system - Red	0 - 100%	0..255	00..FF	0..100
7) Green	Color mixing system - Green	0 - 100%	0..255	00..FF	0..100
8) Blue	Color mixing system - Blue	0 - 100%	0..255	00..FF	0..100
9) White	Color mixing system - White	0 - 100%	0..255	00..FF	0..100
10) Shutter	Shutter closed		0..15	00..0F	0..5.5
	Random Pulse effect	slow - fast	16..47	10..2F	6..18.5
	Up-dimming then Shutter closing (random patterns)	slow - fast	48..79	30..4F	19..31.5
	Shutter open then down-dimming (random patterns)	slow - fast	80..111	50..6F	32..43
	Up-dimming then down-dimming (random patterns)	slow - fast	112..143	70..8F	44..56
	Strobe effect pause	5s .. 1s	144..199	A0..C7	57..77
	Strobe effect, slow - fast	1 Hz .. 10 Hz	200..239	C8..EF	78..94
	Shutter open		240...249	F0..F9	95..97.5
	Shutter open		251..255	FB..FF	99..100
11) Dimmer	Dimmer	0 - 100%	0..255	0..FF	0..100
12) Zoom	Wide - narrow (spot)		0...255	00...FF	0...100
13) Special	Pattern Block 1 → channel 14		0..3	00..03	0..1
	Pattern Block 2 → channel 14		4..7	04..07	1.5..2.5
	Change PWM frequency		100..200	64..C8	40..78
	RESET		250..255	FA..FF	98..100
14) Pattern	No pattern		0..2	00..02	0..1
	250 pre-defined patterns (see appendix A)		03..253	03..FD	2..99

High Resolution (Extended) -Mode 21 DMX Channels

Channel	Function	Time and Value	DMX	HEX	%
1) PAN-coarse	0 .. 623°	3,2s	0..255	00..FF	0..100
2) PAN-fine			0..255	00..FF	0..100
3) Tilt-coarse	0 .. 295°	1,5s	0..255	00..FF	0..100
4) Tilt-fine			0..255	00..FF	0..100

Channel	Function	Time and Value	DMX	HEX	%
5) Red-coarse	Color mixing system – Red	0 - 100%	0..255	00..FF	0..100
6) Red-fine	Color mixing system – Red-Low		0..255	00..FF	0..100
7) Green-coarse	Color mixing system – Green	0 - 100%	0..255	00..FF	0..100
8) Green-fine	Color mixing system – Green-Low		0..255	00..FF	0..100
9) Blue-coarse	Color mixing system – Blue	0 - 100%	0..255	00..FF	0..100
10) Blue-fine	Color mixing system – Blue-Low		0..255	00..FF	0..100
11) White-coarse	Color mixing system – White	0 - 100%	0..255	00..FF	0..100
12) White-fine	Color mixing system – White-Low		0..255	00..FF	0..100
13) Shutter	Shutter closed		0..15	00..0F	0..5.5
	Random Pulse effect	slow - fast	16..47	10..2F	6..18.5
	Up-dimming then Shutter closing (random patterns)	slow - fast	48..79	30..4F	19..31.5
	Shutter open then down-dimming (random patterns)	slow - fast	80..111	50..6F	32..43
	Up-dimming then down-dimming (random patterns)	slow - fast	112..143	70..8F	44..56
	Strobe effect pause	5s - 1s	144..199	A0..C7	57..77
	Strobe effect, slow - fast	1 Hz - 10 Hz	200..239	C8..EF	78..94
	Shutter open		240..249	F0..F9	95..97.5
	Shutter open		251..255	FB..FF	99..100
14) Dimmer-coarse	Dimmer	0 - 100%	0..255	0..FF	0..100
15) Dimmer-fine	Dimmer - Low		0..255	0..FF	0..100
16) Zoom	Spot - Flood		0...255	00...FF	0...100
17) Special	Pattern Block 1 → channel 18		0..3	00..03	0..1
	Pattern Block 2 → channel 18		4..7	04..07	1.5..2.5
	Change PWM frequency		100..200	64..C8	40..78
	RESET		250..255	FA..FF	98..100
18) Pattern	No pattern		0..2	00..02	0..1
	250 pre-defined patterns (see appendix A)		03..253	03..FD	2..99
	Activates direct access to LED Pattern	See channels 18-20	254..255	FE..FF	100
19) Pattern Byte 1	Direct access to Pattern of LED 1..8		0...255	00...FF	0...100
20) Pattern Byte 2	Direct access to Pattern of LED 9..16		0...255	00...FF	0...100
21) Pattern Byte 3	Direct access to Pattern of LED 17..19		0..07	00...07	0..2.5

¹⁾ The predefined colors can be used as start-colors for the Rainbow effect. Please select first a desired start-color before you activate the rainbow effect. All **IMPRESSION X4** will then start from that color and will execute the rainbow effect synchronously. Different **IMPRESSION X4** can have different start-colors but will still execute the rainbow effect synchronously. If you choose a color

different from the ones marked with ¹⁾ in the tables above the rainbow start-color will be red.

²⁾ Rainbow-effect Stop will pause this function. After resuming the rainbow-effect will be continued from the current color.

³⁾ The Rainbow-effect will run synchronously only if started from one of the predefined colors (see also ¹⁾ before).

Locking and unlocking the Control Panel

Please lock and unlock the control panel by pressing the menu keys **MODE & ENTER & UP** at the same time.

Additional Display Indications

As a default you'll find the following additional information in the first row of the LCD display:

Vxx/xx/xx/xx/x

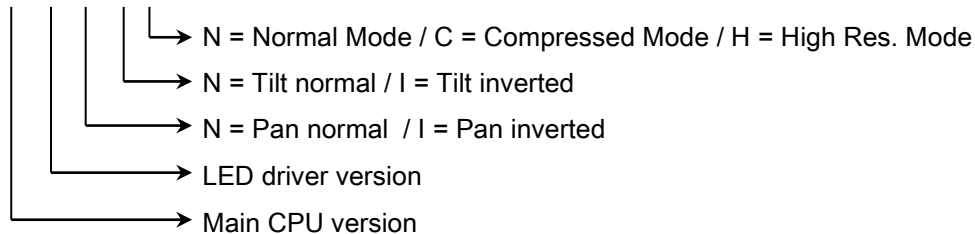

5 Maintaining and Cleaning the IMPRESSION X4

The **IMPRESSION X4** is a fixture of very low maintenance. It is only necessary to clean the air inlets and outlets as well as the optical LED lenses from time to time. For safe operation it is absolutely essential that the fixture is kept clean and that dust, dirt and smoke-fluid residues must not build up on, or within the fixture. Otherwise the fixture's light-output will be significantly reduced or damages can occur. Regular cleaning will not only ensure the maximum light-output, but will also allow the fixture to operate reliably throughout its life.

A soft lint-free cloth moistened with any good glass cleaning fluid is recommended, under no circumstances should alcohol or solvents be used!

5.1 Safety regulations

- **Pull out the mains power plug!**
- Wait min. 15 minutes after disconnecting power to allow the fixture to cool down.

5.2 Maintenance and Interval (rule-of-thumb)

The contamination of the fixture depends on the environment details. Hence no general guidelines can be given. The intervals given below are only suggestions from our experience.

Position	Interval	In this way
LED reflector and optical system	weekly	soft brush /lint-free cloth
Fan and air channel	monthly	vacuum cleaner, airbrush, etc.

Attention:

- **Never let optical parts come into contact with oil or fat.**
- **Before running the fixture wait until all parts are dry.**
- **Never touch lenses with bare fingers.**

6 Technical Specifications

Power supply	
Power consumption	350 VA (Watt)
Power Input	~100-240 V AC, 50-60 Hz (wide range input)
Fuse protection	Micro-fuse 5x20 mm, T5A
Operational Parameters	
Max. Ambient Temperature	5° - 45°C (integrated overheating switch)
Mounting Position	Any (see relevant chapter)
Lighting System - Additive Color mixing	
LED Type	19 x Osram Ostar RGBW multi-chip
Lifetime	50,000 h
Wavelength optimized for maximum presentable color space	
Optical System	
Full RGBW / High efficient Collimator cluster	
Shutter / Dimmer (8/16 Bit)	
Strobe- Effect with variable speed between 1 - 10 flashes per second, Random-Strobe, Pulse-Effects	
Continuous Dimmer 0 - 100%	
Zoom	
7 to 50 degree continuous zoom	
Optical Patterns	
Several hundred pre-defined beam patterns with direct access and manipulation	
DMX Control	
Standard USITT DMX-512, 5 pin XLR; [+] = Pin 3 / [-] = Pin 2 / [Ground] = Pin 1 / Pin 4&5 N.C. Die DMX- Addressing starts at the DMX channel [001].	
Pan / Tilt (8/16 Bit)	
Pan- movement	623° in min. 3,2 seconds (Position Feedback)
Tilt- movement	295° in min. 1,5 seconds (Position Feedback)
Weights and Measures	
Width of the base	341 mm
Length of the base	145 mm
height (head vertical)	375 mm (incl. standing foot/tripod)
Weight (net)	8.0 kg

7 Dimensions

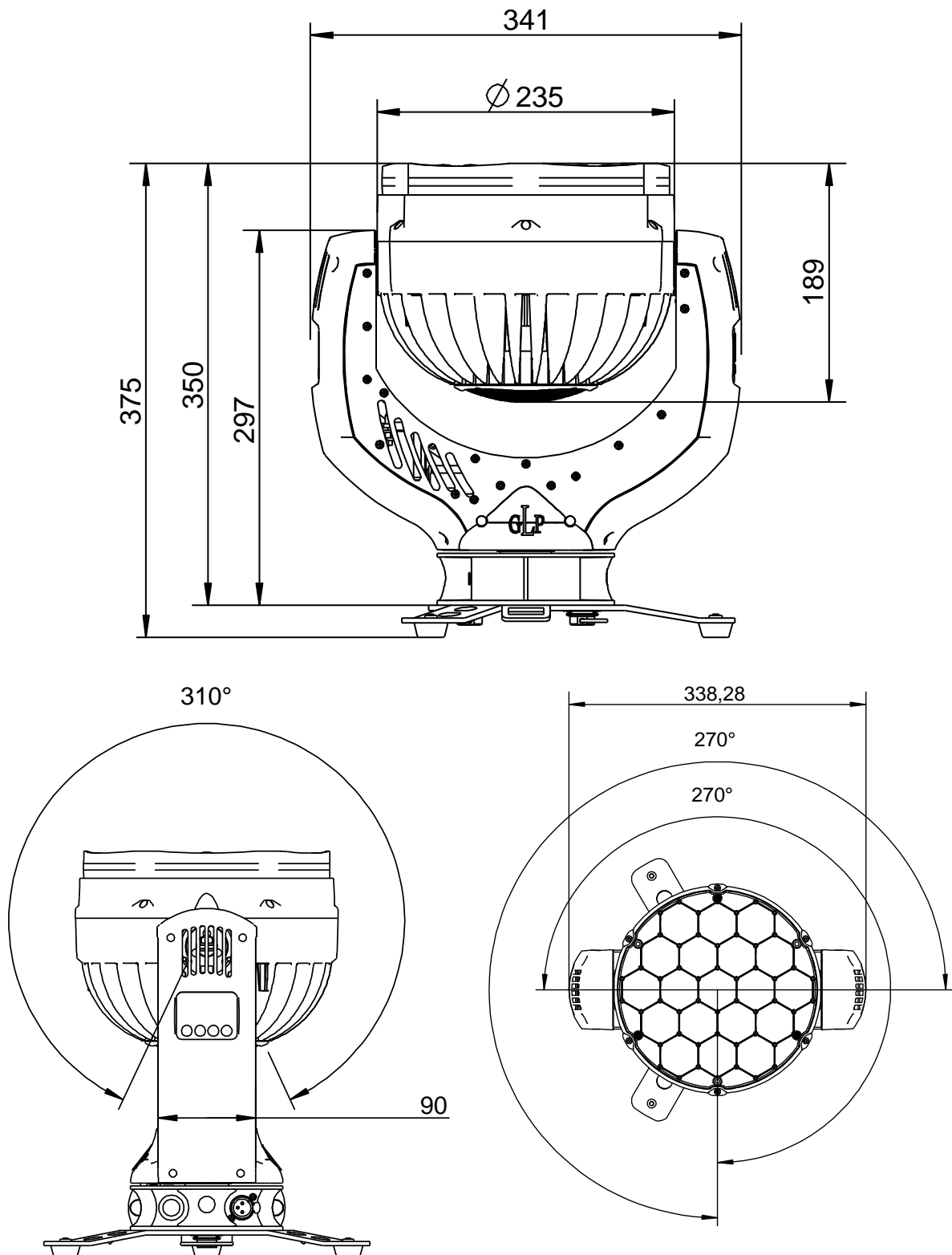

8 Index

B	
beam-lights	6
BGV C1.....	7
C	
Camlock.....	8
Cleaning.....	18
Compress-Mode	14
D	
Danger of BURNING	5
Description of Device.....	4
Dimensions	20
DIN VDE 0711-217	7
Display Indications	17
DMX	10
E	
e-mail.....	1
EN 60598-2-17	9
Enter-key	10
Eyelets	8
H	
Half-couplers (clamps).....	9
High Resolution (Extended) -Mode	16
I	
Instruction Version.....	1
Internet.....	1
L	
LED Class 2M	5
M	
Maintenance	18
Menu Field.....	10
Micro-fuse.....	10
Mode-key	10
Mounting	7
Mounting in hanging Position.....	8
Mounting in sidewise Position.....	9
Mounting on the Floor	8
N	
Normal-Mode	13
O	
Optical parts	18
P	
Pan- Movement.....	19
Patterns.....	22
plano-convex lenses	6
Power Supply	10
Powercon	4
R	
RESET	13
S	
Safety distance	7
Safety information	6
Safety Instructions	5
Secure the Device	9
Software Version.....	1
sunlight.....	6
T	
Technical Specifications	19
Tilt- Movement	19
U	
Up/Down-keys	10
V	
VBG 70	7
W	
Warranty claims	5
Weights and Measures	19

9 Pattern

Patterns are grouped into two sets which can be activated and selected via the DMX channel "Special". Choose the desired pattern by its corresponding DMX value on channel "Pattern".

Orientation: Patterns are shown when looking at the **front** of a standing fixture; Head faced in direction of fixtures front label: DMX Pan @ 128; Tilt @ 220; Zoom @ 255 (letters are displayed homogenous).

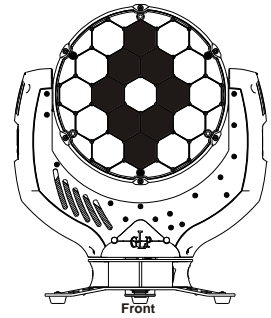

Patterns Set 1

DMX	Pattern	DMX	Pattern	DMX	Pattern	DMX	Pattern
000		013		026		039	
001		014		027		040	
002		015		028		041	
003		016		029		042	
004		017		030		043	
005		018		031		044	
006		019		032		045	
007		020		033		046	
008		021		034		047	
009		022		035		048	
010		023		036		049	
011		024		037		050	
012		025		038		051	

DMX	Pattern
052	
053	
054	
055	
056	
057	
058	
059	
060	
061	
062	
063	
064	
065	
066	
067	
068	

DMX	Pattern
069	
070	
071	
072	
073	
074	
075	
076	
077	
078	
079	
080	
081	
082	
083	
084	
085	

DMX	Pattern
086	
087	
088	
089	
090	
091	
092	
093	
094	
095	
096	
097	
098	
099	
100	
101	
102	

DMX	Pattern
103	
104	
105	
106	
107	
108	
109	
110	
111	
112	
113	
114	
115	
116	
117	
118	
119	

DMX	Pattern
120	
121	
122	
123	
124	
125	
126	
127	
128	
129	
130	
131	
132	
133	
134	
135	
136	

DMX	Pattern
137	
138	
139	
140	
141	
142	
143	
144	
145	
146	
147	
148	
149	
150	
151	
152	
153	

DMX	Pattern
154	
155	
156	
157	
158	
159	
160	
161	
162	
163	
164	
165	
166	
167	
168	
169	
170	

DMX	Pattern
171	
172	
173	
174	
175	
176	
177	
178	
179	
180	
181	
182	
183	
184	
185	
186	
187	

DMX	Pattern
188	
189	
190	
191	
192	
193	
194	
195	
196	
197	
198	
199	
200	
201	
202	
203	
204	

DMX	Pattern
205	
206	
207	
208	
209	
210	
211	
212	
213	
214	
215	
216	
217	
218	
219	
220	
221	

DMX	Pattern
222	
223	
224	
225	
226	
227	
228	
229	
230	
231	
232	
233	
234	
235	
236	
237	
238	

DMX	Pattern
239	
240	
241	
242	
243	
244	
245	
246	
247	
248	
249	
250	
251	
252	
253	reserved
254	reserved
255	reserved

Patterns Set 2

DMX	Pattern
000	
001	
002	
003	
004	
005	
006	
007	
008	
009	
010	
011	
012	
013	
014	
015	
016	

DMX	Pattern
017	
018	
019	
020	
021	
022	
023	
024	
025	
026	
027	
028	
029	
030	
031	
032	
033	

DMX	Pattern
034	
035	
036	
037	
038	
039	
040	
041	
042	
043	
044	
045	
046	
047	
048	
049	
050	

DMX	Pattern
051	
052	
053	
054	
055	
056	
057	
058	
059	-

