

NBB-04R Networked Audio Receiver

NBB-04T Networked Audio Transmitter



Overview:

The NBB-04R receives 4 channels of analog audio and converts them into Dante networked audio stream which in turn can be received by other Dante-enabled devices such as digital audio console or DAW; While the NBB-04T, in contrast, transmits 4 channels of analog audio converted from Dante networked audio stream which is distributed from other Dante-enabled devices.

Both NBB-04R and NBB-04T are equipped with two RJ-45 Ethernet ports so that several NBB-04R/NBB-04T can be cascaded, i.e. in daisy-chaining, in the same network link. Also both NBB-04R and NBB-04T can be powered by either PoE from Ethernet switch or 48V from external power adapter.

Features:

- Dante-enabled networked Audio Receiver (NBB-04R) and Transmitter (NBB-04T)
- Streaming audio in robust standard Ethernet cable (a.k.a., Digital Snake)
- Easily organize and expand network topology with Ethernet switches
- Uncompressed 24-bit PCM coding with sample rate up to 96KHz
- Two RJ-45 ports make Daisy-chain cascading feasible
- Powered by either PoE or 48V adapter
- Gain or Attenuate control for each channel
- Phantom power engagement control per channel (NBB-04R)
- A signal clip indicator for all inputs (NBB-04R)
- XLR Combo sockets for both XLR and TRS phone plugging (NBB-04R)
- Routing and other configuration are set with Dante Controller software

Description:

The NBB-04R and NBB-04T adopt Audinate Dante networking technology for audio transceiving, and are very network friendly with unlimited flexibility in topology of deployment. They support up to



Layer 3 of IEEE 802.3 network standard, enabling you to organize your audio network with the on-the-shelf Ethernet switches or to immediately transport streaming audio by taking advantage of your existing installed network facility with no hassle. Even better, every NBB-04R/NBB-04T comes with two Ethernet ports which allow you to physically cascade several NBB-04Rs/NBB-04Ts in the same network link. Accompanying with Ethernet switches, this capability helps NBB-04R/NBB-04T gaining flexibility and expanding territory in device deployment in audio networking.

Audio routing among NBB-04Rs/NBB-04Ts and all the other Dante-enabled devices is configured via computer with dedicated Dante Controller software which is available free from Audinate website. With Dante Virtual Soundcard software, you are even able to have your DAW software direct record/play multitrack streaming audio from/to NBB-04R/NBB-04T.

The audio input/output interfaces of NBB-04R/NBB-04T are fully met the requirement of professional audio industrial. Audio is encoded/decoded with the latest and uncompressed 24-bit PCM encoder/decoder with sample rate in 44.1KHz, 48KHz, or 96KHz. The NBB-04T outputs are peculiarly buffered with amplifiers of high-rail-voltage which can drive the lines up to 24dBu. Besides the high-level of drive capability, the output of NBB-04T can also be attenuated to meet the narrower reception range of inputs of some semi-professional devices. All inputs of NBB-04R accept signal of level from mic to line with individual gain and phantom power control. The NBB-04R is also equipped with a clip indicator for all the inputs to warn audio technician any signal overload on inputs.

The NBB-04R/NBB-04T is assembled in a sturdy metal chassis with four bumpers on the edges. This we think is very important for you to damp the NBB-04R/NBB-04T from accidental smash during field installation.

Getting Started Guide:

Powering

The NBB-04R and NBB-04T can be powered by either,

- PoE from Ethernet switch with PoE PSE capability, or
- 48V power adapter which should be included in your device package.

It is O.K. for you to power your NBB-04R/NBB-04T with both PoE and 48V adapter simultaneously. However, since the operating voltage of PoE is usually higher than 48V, very likely your NBB-04R/NBB-04T will sink power only from PoE if you do so.

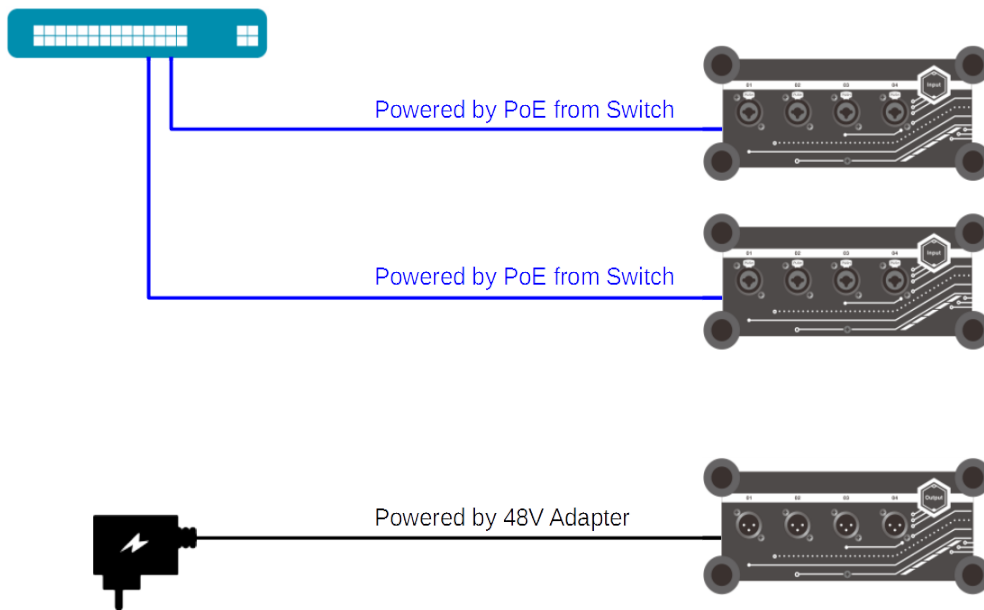

Setting

Once your NBB-04R/NBB-04T is powered, you can configure your NBB-04R/NBB-04T by direct connecting it to your computer or via the Ethernet switch. That is to say that the NBB-04R/NBB-04T can direct talk to your computer or via switch. See picture below for an illustration.

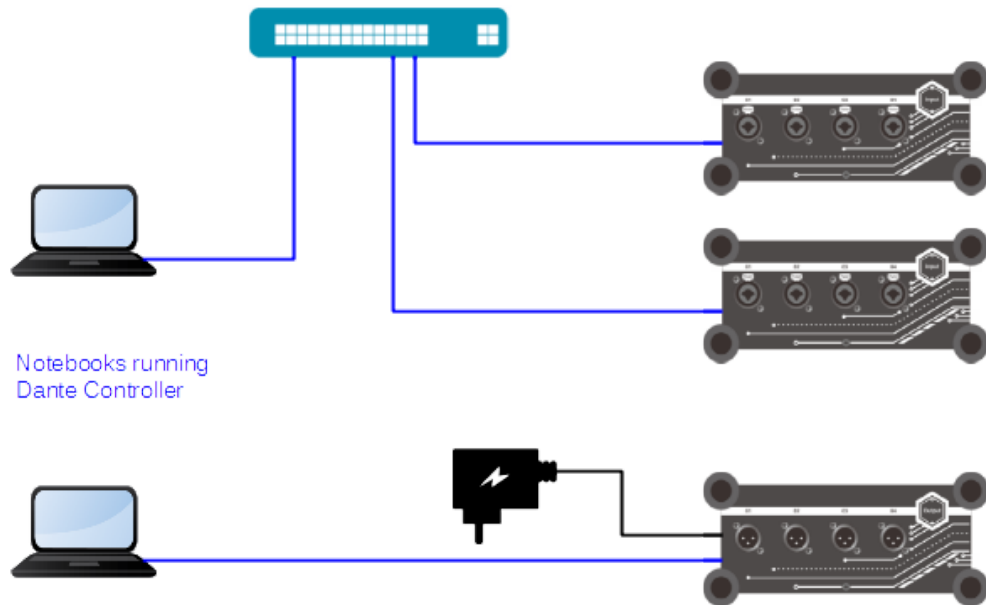

All the routing assignment and device configuration are set via Dante Controller software which is available free from the following Audinate webpage,

www.audinate.com/products/software/dante-controller

User's guide of Dante Controller can be found on the following webpage,

www.audinate.com/resources/technical-documentation

Besides the routing assignment, mostly, **you should set the operating sample rate of your NBB-04R/NBB-04T to meet the sample rate of your whole Dante network.** Basically, all the devices in the same Dante network should be synced to the same sample rate. You do not need to worry about the bit-depth of coding of your audio stream in network. Although the NBB-04R/NBB-04T encodes/decodes audio in 24-bit PCM stream, it automatically does bit-depth converting when it streams audio to/from other Dante-enabled devices manipulating audio data in different bit-depth.

By default, the NBB-04R device transmits one or a couple of channels of audio in flow to a single particular device in remote. The NBB-04R supports merely 2 audio flows simultaneously. When you need the audio received from NBB-04R to be transmitted to more than 2 devices, you can assign the channels needed to be transmitted to more than 2 remote devices in a multicast flow by clicking the multicast button in the device view window in Dante Controller.

Usually, UTP (Unshielded Twisted Pair) Cat.5e cable should be good enough for all the network installation. However, STP (Shielded Twisted Pair) Cat.5e cable is strongly recommended if you plan to route the cable through noisy environment. The foil or braided screens in STP cable can provide great noise immunity from electromagnetic interference around.

Also, make sure the EIA/TIA-568B standard is fully followed for the RJ-45 plug wiring.

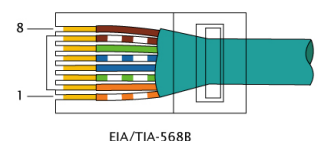

Front Panel



To accommodate all the variety of field installation, the front panels of NBB-04R and NBB-04T are equipped with rich control facilities as follows,

1. The Gain control knobs of NBB-04R can accommodate itself to accept all kind of sources with level from mic to line.
2. The +48V button to control whether to deliver phantom power to power source device or not.
3. The clip indicator flashes to warns audio technicians if any of inputs is overloaded.
4. The SYS LED indicates system activity,
 - Red: system booting
 - Green: system ready
5. The SYNC LED indicates the PTP clocking status,
 - Green: PTP is synced
 - Amber: PTP is syncing
 - Red: PTP error
 - Green & flashing: the device is elevated to PTP clock master.
6. The Att control knobs of NBB-04T can be used to attenuate output down to -20dB from nominal maximum.

Side Panels

The two Ethernet ports actually belongs to the two physical ports in the internal mini switch in NBB-04R/NBB-04T. This network switch capability allows several NBB-04Rs/NBB-04Ts to be cascaded in the same Ethernet link for network expanding. The NBB-04R/NBB-04T can be powered by either of these two ports, provided the the Ethernet cable on it is from a Ethernet switch with PoE PSE capability. Please be informed that NBB-04R/NBB-04T does not have the PoE PSE capability to power the next cascaded PoE PD device, although itself can be powered by PoE.

Besides powered by the Ethernet switch with PoE PSE capability, the NBB-04R/NBB-04T can also be powered by a 48V power adapter. We ship NBB-04R/NBB-04T with a 48V adapter in the package in case you don't have Ethernet switch with PoE PSE capability.

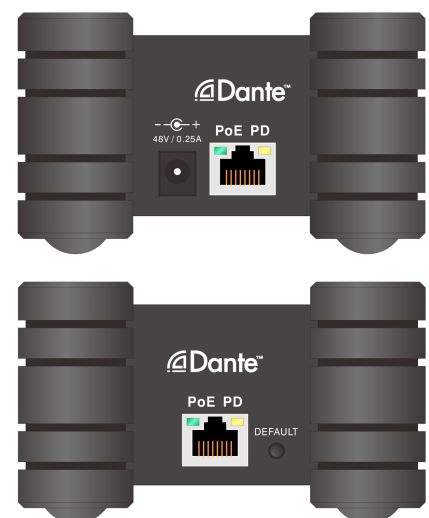

A default button on one of the side panels is used to restore the settings of NBB-04R/NBB-04T to factory default. Press and hold the switch when you powering up the device will restore the device to default state. Once you see both SYS and SYNC LEDs red, you can then re-power the device for the default settings to take effect. The cap of the default button is sunk to panel to avoid your accidentally triggering the action of default restoring.

Top Panel

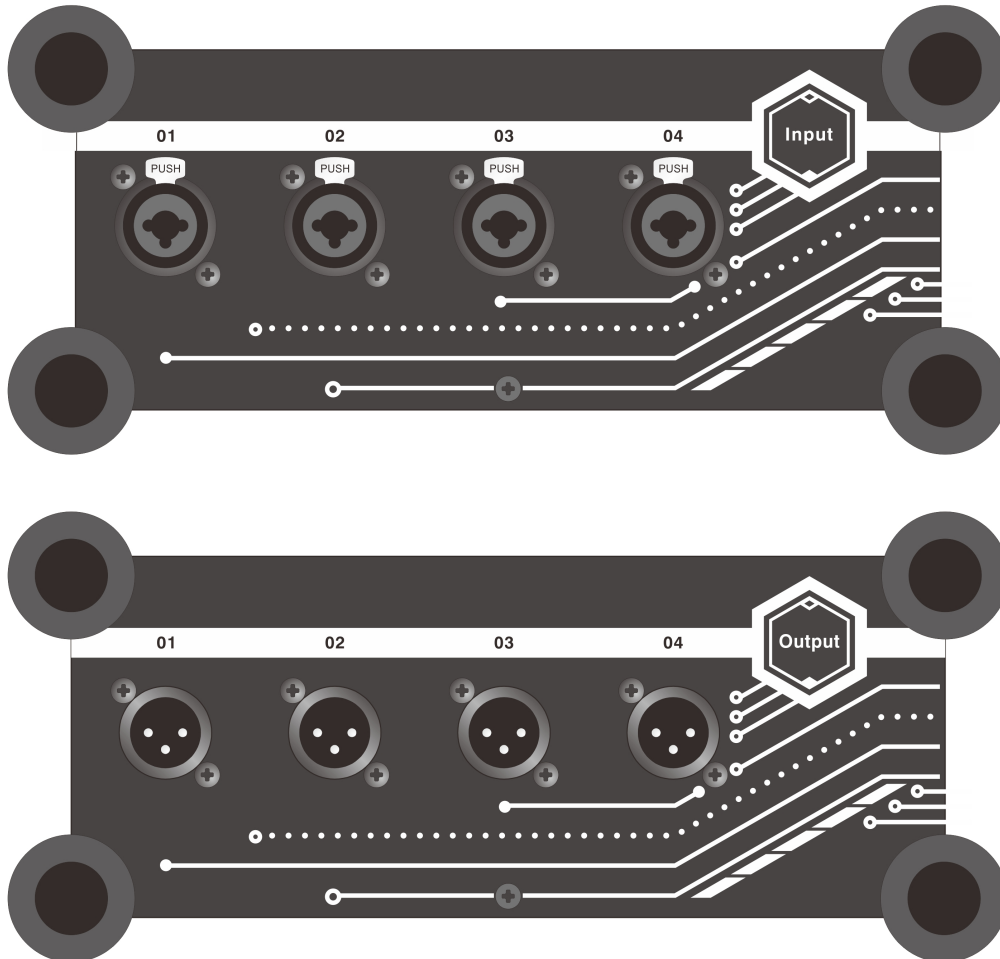

The 0dB level is nominal to 24dBu in both input and output. That means the NBB-04R can accept input level up to 24dBu from the balanced XLR or TRS phone plug; while the NBB-04T can drive the output up to 24dBu via the balanced XLR. To get flat frequency response, please be informed that the balanced XLR outputs are all direct and transformerless coupling. **Please do not short either pin 2 or pin 3 of any output XLR to pin 1 of itself** if the output is destined at unbalanced input. You can, however, simply float pin 3 and drive the unbalanced input with pin 2 and pin 1 merely.

Bottom Panel

This is where you can find the serial number and the factory assigned Dante default name of your NBB-04R/NBB-04T. The Dante name of your device can be changed to whatever you like by using Dante Controller software.

Applications:

Direct Connecting to Notebook or Console

One of the beauty of Dante is that you do not need a DHCP server or router in between to establish all kind of communication among different Dante-enabled devices. You can even connect your UNiKA Dante-enabled devices to your computer or digital console without an Ethernet switch in between. Since all UNiKA Dante-enabled devices actually have a mini switch built-in, you are also able to cascade several of your devices in the same link by taking advantage of the two RJ-45 ports on your UNiKA Dante-enabled devices.

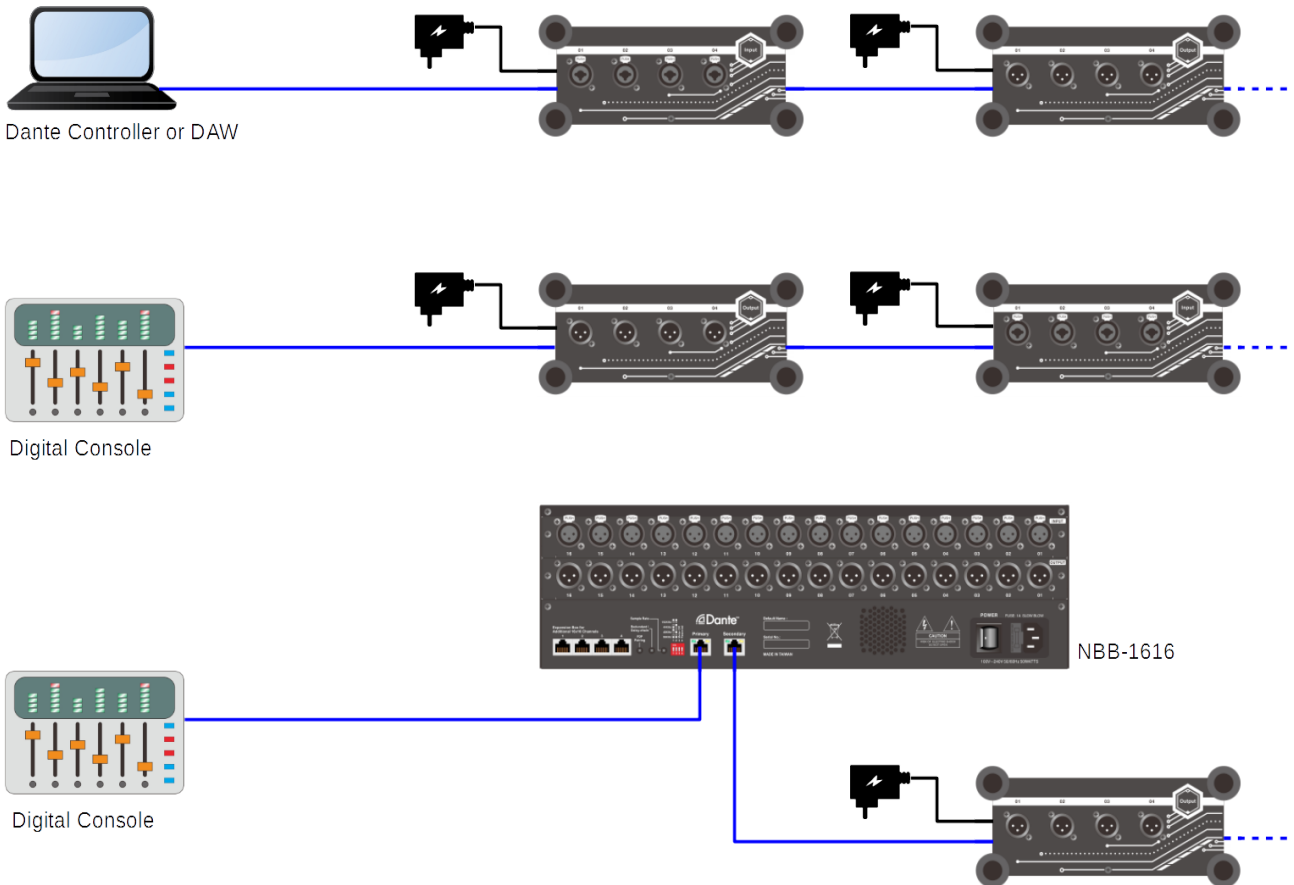

Connecting via Ethernet Switch

Once your audio network grows up to turn complex, you may want to add Ethernet switches in your audio network so that you can better manage the cabling among all your Dante-enabled devices. For a large-scale system, you may even have several Ethernet switches in your audio network. The switches, including the mini switch in UNiKA Dante-enabled devices, do cause propagation delay but fortunately every one of them only contribute delay in several tens of microseconds.

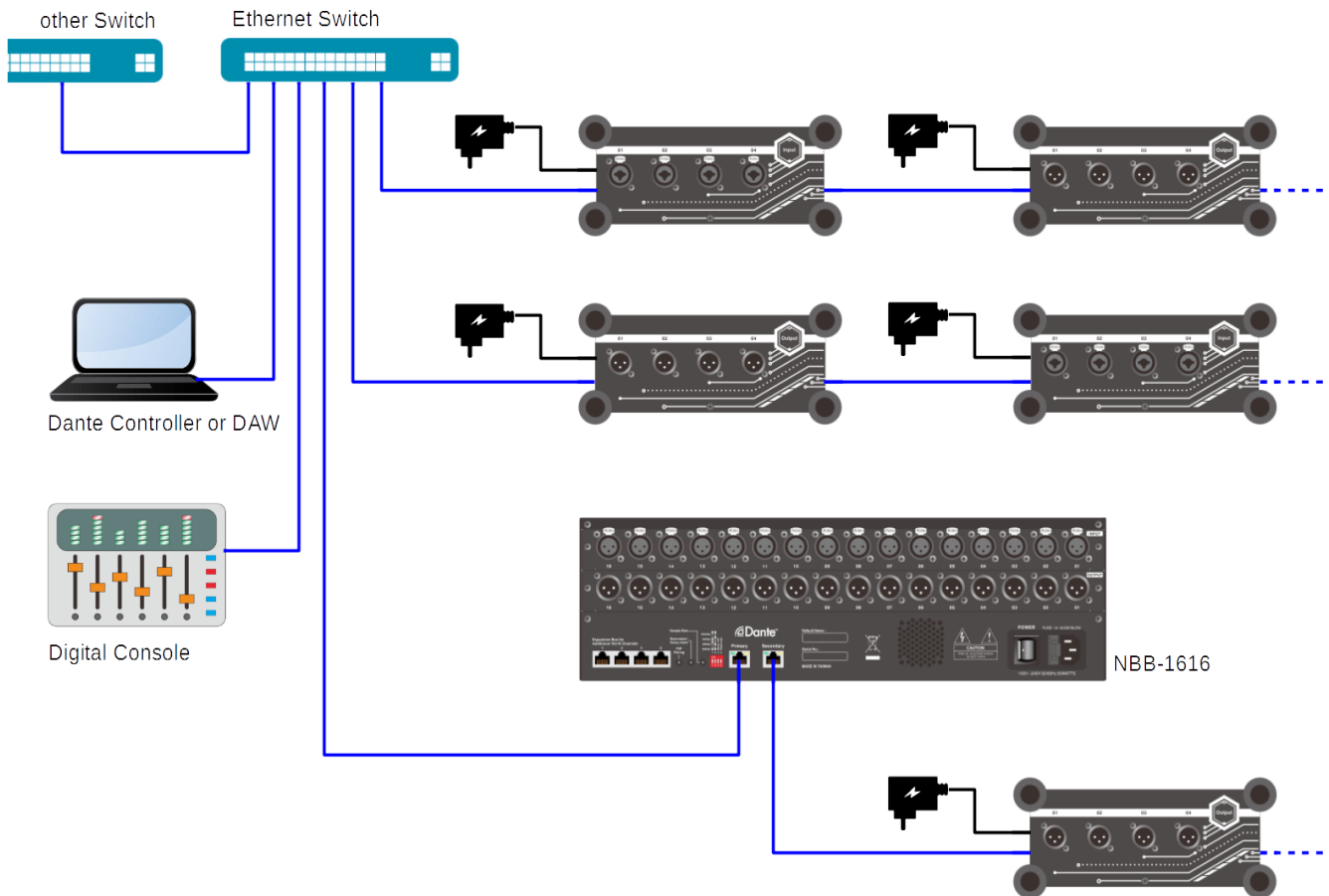

Connecting via Switch with PoE PSE Capability

Both NBB-04R and NBB-04T support to be powered by Ethernet PoE, so that you don't need a 48V wall adapter if your NBB-04R/NBB-04T direct connects to an Ethernet switch with PoE PSE capability.

Also, you are allowed have have more than one console in your audio network, but keep in mind that only one of them can be set to be a clock master for the whole network. The clock master provides word clock for audio framing synchronization. All the other Dante-enabled devices in the same network should be synced to the same master clock.

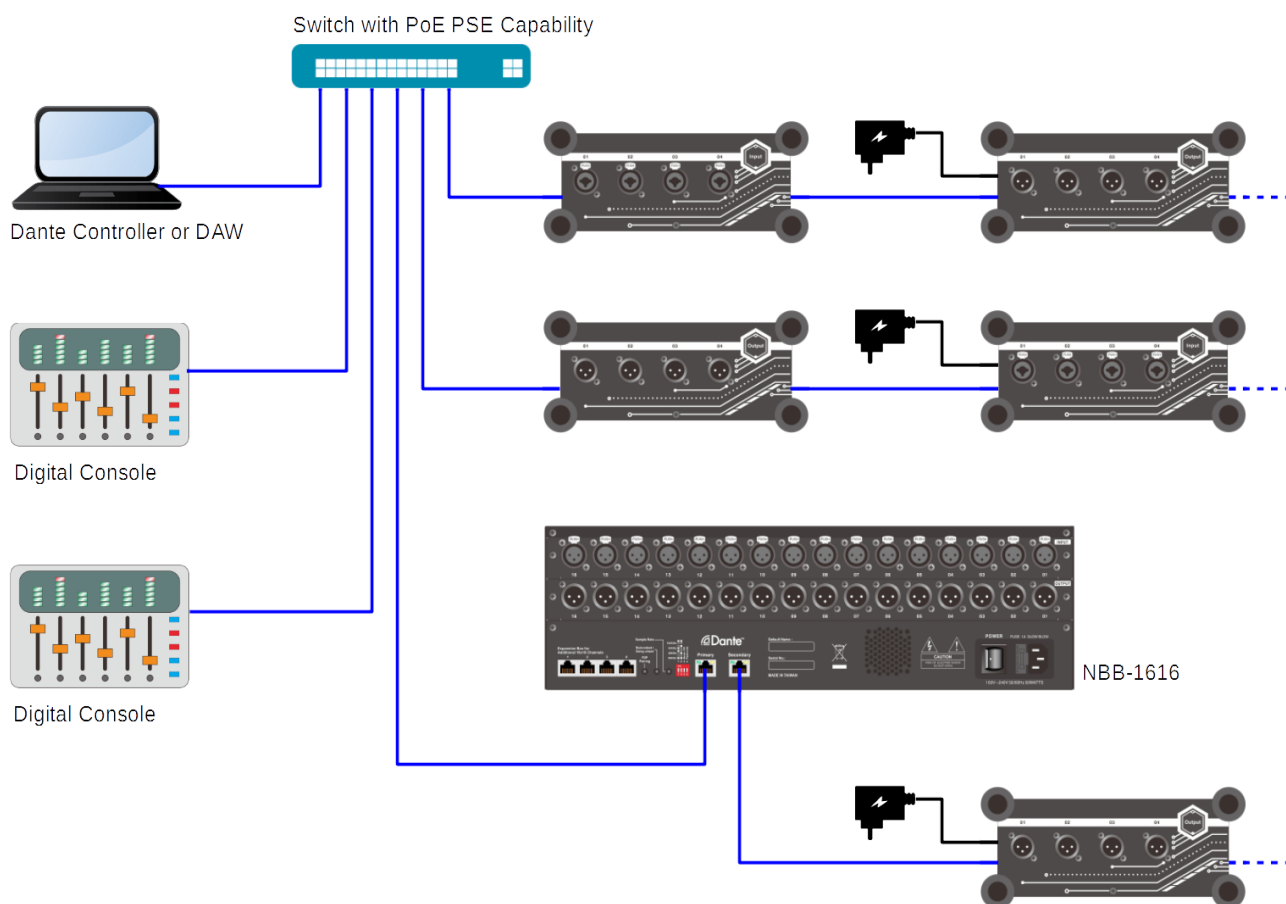

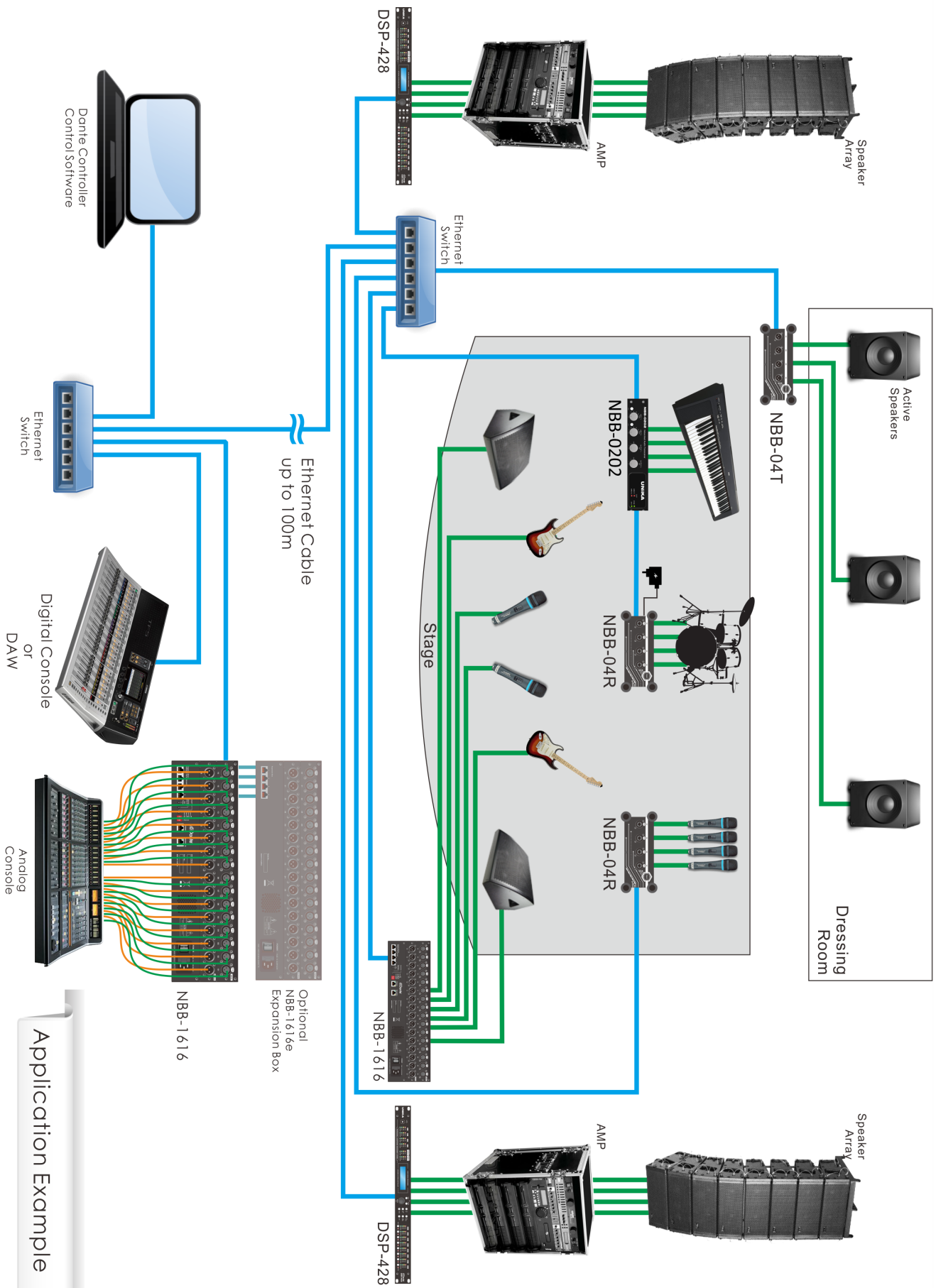

Application Example

Specifications:

Model	NBB-04R	NBB-04T
Channel Capacity	x4 Inputs	x4 Outputs
Audio Connector	XLR/TRS Combo	XLR
Level	24dBu max.	24dBu max.
Clip Indicator	x1	N.A.
Gain/Volume Control	60dB Rotary	-20dB Rotary
+48V Phantom Power	ON/OFF per Input	N.A.
Digitized Scaling	0dBFS @24dBu	
Encoding	Uncompressed 24-bit PCM	
Sample Rate	44.1KHz / 48KHz / 96KHz	
Ethernet	x2 Gigabit RJ45 Ports	
Networking Mode	Switch Mode (a.k.a. Daisy-chain Mode)	
Node to Node Distance	100m with Cat.5e Cable	
Audio Latency	< 2ms typical	
Audio Flows	x2 (unicast + multicast)	N.A.
Frequency Response	20Hz ~ 20KHz \pm 0.5dB	
S/N Ratio	> 100dB @0dBFS	> 110dB @0dBFS
THD + Noise	< 0.002% @-10dBFS	< 0.001% @-10dBFS
Dynamic Range	> 100dB	> 110dB
Crosstalk	< -100dB @10KHz	< -120dB @10KHz
Powered by Adapter	48VDC, 0.25A (rated)	
Powered by PoE	55VDC, 0.25A (rated)	
Power Consumption	< 6Watts	
Operation Temperature	0 ~ 45°C	
Operation Rel. Humidity	0 ~ 90%	
Construction	Metal Chassis with Shock Dampers	
Dimensions (HxWxD)	67mm x 237mm x 114mm	63mm x 237mm x 114mm
Weight	900g	860g

The above information is subject to change without notice.

All the above test result are measured with no signal weighting.

UNiKA Electronic Co., Ltd.

www.unikapro.com

6F, No.168, XinHu 2nd Road,
NeiHu Dist., Taipei 11494,
Taiwan (R.O.C.)

☎ +886-2-27933017

✉ info@unikapro.com

Cautions and Important Safety Instructions

- minimum distances around the apparatus for sufficient ventilation;
- the ventilation should not be impeded by covering the ventilation openings with items, such as newspapers, table-cloths, curtains, etc.;
- no naked flame sources, such as lighted candles, should be placed on the apparatus;
- attention should be drawn to the environmental aspects of battery disposal;
- the use of apparatus in the tropical and/or moderate climates.

UNiKA products are designed and manufactured in the Taiwan to the highest quality standard. However, if something does go wrong with a product, UNiKA Electronic Co., Ltd. will repair or replace such product in accordance with this warranty policy in any country served by an authorized UNiKA distributor. This warranty complements any national or regional law obligations of dealers, partner or national distributors and does not affect your statutory rights as a consumer. This warranty will only apply to products by purchased from legal UNiKA distributor or dealer, partner etc. This warranty will be effective from the serial number and initial date of purchase and will be valid for the warranty periods detailed as distributor's sales and service document. No claim under this warranty will be valid unless accompanied by proof of purchase of the product to which the warranty claim relates. This warranty is transferable from owner to owner and will apply and remain with the product to which it relates from the initial date of purchase for the specified term in the distributor's Area, as long as it's supported with the original proof of purchase.

UNiKA Service and Warranty Form

Model	<input type="checkbox"/> NBB-04R <input type="checkbox"/> NBB-04T	Date	
User/Buyer information			
Company		Contact	
Tel		Fax	
Website		eMail	
Distributor/Dealer			
Contact		Remark	
Warranty valid date			
Signature and Stamp			