



the
box **pro**

Achat 206
passive speaker

Musikhaus Thomann
Thomann GmbH
Hans-Thomann-Straße 1
96138 Burgebrach
Germany
Telephone: +49 (0) 9546 9223-0
E-mail: info@thomann.de
Internet: www.thomann.de

22.09.2021, ID: 277960, 277958 (V4)

Table of contents

1	General information	4
	1.1 Further information.....	5
	1.2 Symbols and signal words.....	6
2	Safety instructions	8
3	Features	11
4	Installation	12
	4.1 Tips on handling speakers.....	13
	4.2 Installation.....	14
	4.3 Connections.....	17
5	Technical specifications	19
6	Plug and connection assignment	24
7	Protecting the environment	25

1 General information

This user manual contains important information on the safe operation of the device. Read and follow all safety notes and all instructions. Save this manual for future reference. Make sure that it is available to all persons using this device. If you sell the device to another user, be sure that they also receive this manual.

Our products and user manuals are subject to a process of continuous development. We therefore reserve the right to make changes without notice. Please refer to the latest version of the user manual which is ready for download under www.thomann.de.

1.1 Further information



On our website (www.thomann.de) you will find lots of further information and details on the following points:

Download	This manual is also available as PDF file for you to download.
Keyword search	Use the search function in the electronic version to find the topics of interest for you quickly.
Online guides	Our online guides provide detailed information on technical basics and terms.
Personal consultation	For personal consultation please contact our technical hotline.
Service	If you have any problems with the device the customer service will gladly assist you.

1.2 Symbols and signal words

In this section you will find an overview of the meaning of symbols and signal words that are used in this manual.

Signal word	Meaning
DANGER!	This combination of symbol and signal word indicates an immediate dangerous situation that will result in death or serious injury if it is not avoided.
WARNING!	This combination of symbol and signal word indicates a possible dangerous situation that can result in death or serious injury if it is not avoided.
CAUTION!	This combination of symbol and signal word indicates a possible dangerous situation that can result in minor injury if it is not avoided.
NOTICE!	This combination of symbol and signal word indicates a possible dangerous situation that can result in material and environmental damage if it is not avoided.

Warning signs	Type of danger
	Warning – high-voltage.
	Warning – suspended load.
	Warning – danger zone.

2 Safety instructions

Intended use

This device is designed for sound reinforcement. Use the device only as described in this user manual. Any other use or use under other operating conditions is considered to be improper and may result in personal injury or property damage. No liability will be assumed for damages resulting from improper use.

This device may be used only by persons with sufficient physical, sensorial, and intellectual abilities and having corresponding knowledge and experience. Other persons may use this device only if they are supervised or instructed by a person who is responsible for their safety.

Safety



DANGER!

Danger for children

Ensure that plastic bags, packaging, etc. are disposed of properly and are not within reach of babies and young children. Choking hazard! Ensure that children do not detach any small parts (e.g. knobs or the like) from the unit. They could swallow the pieces and choke! Never let children unattended use electrical devices.



DANGER!

Electric shock caused by high voltages at the power amplifier output

The output voltages of modern high-performance amplifiers may result in death or serious injury. Never touch the bare ends of loud-speaker cables when the amplifier is on.



WARNING!

Consequences of faulty mounting

Faulty mounting may lead to lethal injuries or property damage. Please ensure that the norms and regulations valid in your country are always observed when mounting and operating your product. In Germany: DGUV rule 17 „Veranstaltungs- und Produktionsstätten für szenische Darstellung“ (event and production sites for stage presentations). Only expertly trained staff may mount speakers.



WARNING!

Risk of injury caused by falling objects

Portable PA systems should be secured from falling using two independently working devices, for example, safety ropes.



CAUTION!

Possible hearing damage

The device can produce volume levels that may cause temporary or permanent hearing impairment. Over an extended period of time, even levels that seem to be uncritical can cause hearing damage. Decrease the volume level immediately if you experience ringing in your ears or hearing impairment. If this is not possible, keep a greater distance or use sufficient ear protectors.



NOTICE!

Operating conditions



This device has been designed for indoor use only. To prevent damage, never expose the device to any liquid or moisture. Avoid direct sunlight, heavy dirt, and strong vibrations. Only operate the device within the ambient conditions specified in the chapter 'Technical specifications' of this user manual. Avoid heavy temperature fluctuations and do not switch the device on immediately after it was exposed to temperature fluctuations (for example after transport at low outside temperatures). Dust and dirt inside can damage the unit. When operated in harmful ambient conditions (dust, smoke, nicotine, fog, etc.), the unit should be maintained by qualified service personnel at regular intervals to prevent overheating and other malfunction.



NOTICE!

Possible staining



The plasticiser contained in the rubber feet of this product may possibly react with the coating of your parquet, linoleum, laminate or PVC floor and after some time cause permanent dark stains. In case of doubt, do not put the rubber feet directly on the floor, but use felt-pad floor protectors or a carpet.



NOTICE!

Possible property damage by magnetic fields



Loudspeakers produce a static magnetic field. Therefore, maintain an appropriate distance to devices that can be adversely affected or damaged by an external magnetic field.

3 Features

Special features of this powerful and compact full-range speaker:

- 2 × 6" woofer, 1" compression tweeter
- Connection options: 2 lockable NL4 sockets (1+/1–), screw terminals
- M10 rigging points
- Speaker stand flange
- Optional horizontal and vertical brackets available:
 - the box pro 206 U bracket vertical black (item no. 283312): Vertical mounting bracket black
 - the box pro 206 U bracket vertical white (item no. 302854): Vertical mounting bracket white
 - the box pro 206 U bracket horizontal black (item no. 283311): Horizontal mounting bracket black
 - the box pro 206 U bracket horizontal white (item no. 302855): Horizontal mounting bracket white
- Black textured paint for item no. 277560
- White textured paint for item no. 277958
- Cover (optionally available, item no. 385906)

4 Installation

Unpack and check carefully there is no transportation damage before using the unit. Keep the equipment packaging. To fully protect the product against vibration, dust and moisture during transportation or storage use the original packaging or your own packaging material suitable for transport or storage, respectively.

Create all connections while the device is off. Use the shortest possible high-quality cables for all connections. Take care when running the cables to prevent tripping hazards.



DANGER!

Electric shock caused by high voltages at the power amplifier output

The output voltages of modern high-performance amplifiers may result in death or serious injury.

Never touch the bare ends of loudspeaker cables when the amplifier is on.

4.1 Tips on handling speakers

We recommend you to set up the speakers in a way, that the sound signals can reach the audience unobstructedly. It will often be helpful to mount the speakers on tripods. Thus, the sound will be evenly spread with maximum range throughout the audience area.

Always use high grade cable to connect your equipment. Otherwise you won't reach maximum sound quality.

For optimum results both impedance and power handling of the speakers must match the requirements of the amplifier. Always follow the technical specifications of the speakers! The overall impedance of the connected loudspeakers must not exceed the minimum output impedance of the amp. The amps max. RMS output power should be 50 % above the power handling capacity of the connected speakers.

If you notice distortion during operation, either the amp or the speaker is overloaded. This may permanently damage the amp or the speaker. Always reduce the volume when you hear distortion.

4.2 Installation



WARNING!

Consequences of faulty mounting

Faulty mounting may lead to lethal injuries or property damage.

Please ensure that the norms and regulations valid in your country are always observed when mounting and operating your product. In Germany: DGUV rule 17 „Veranstaltungs- und Produktionsstätten für szenische Darstellung“ (event and production sites for stage presentations). Only expertly trained staff may mount speakers.



NOTICE!

Possible property damage by magnetic fields

Loudspeakers produce a static magnetic field. Therefore, maintain an appropriate distance to devices that can be adversely affected or damaged by an external magnetic field.

Mounting options

You can install the device standing or hanging upside down. When in use, the device must be mounted at a solid surface or clamped to an approved truss.

Standing mounting



NOTICE!

Use of stands

When mounting the device onto a stand, ensure that the stand is in a safe and stable position and that the weight of the device does not exceed the maximum permissible load capacity of the stand.

We recommend that the speaker be set up so that the lower edge is located 185 cm above the floor.

For mounting on a standard tripod (suitable tripod for direct connection: Item no. 174340), the flange cover on the bottom of the speaker must be removed (four screws).

Suspended mounting

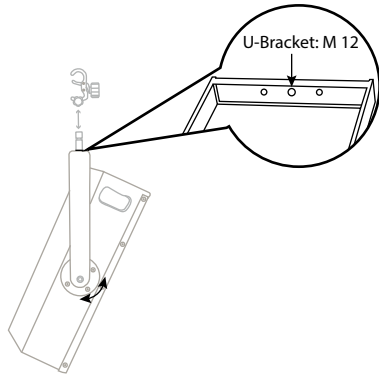

The optionally available vertical and horizontal mounting brackets (U brackets) allow you to attach the speaker stably and securely to the wall, ceiling or half coupler and thus to trusses.



WARNING!

Risk of injury caused by falling objects

Portable PA systems should be secured from falling using two independently working devices, for example, safety ropes.

The load capacity of trusses or other fixtures must be sufficient for the intended number of devices. The personnel in charge of mounting the suspension system are responsible for ensuring that the systems are set up and used safely.

Always work from a stable platform whenever installing, moving or servicing the unit. In doing so, the area underneath the unit must be cordoned off. Only persons directly involved in set-up and removal are authorized to be in the assembly area.

4.3 Connections

Installation methods

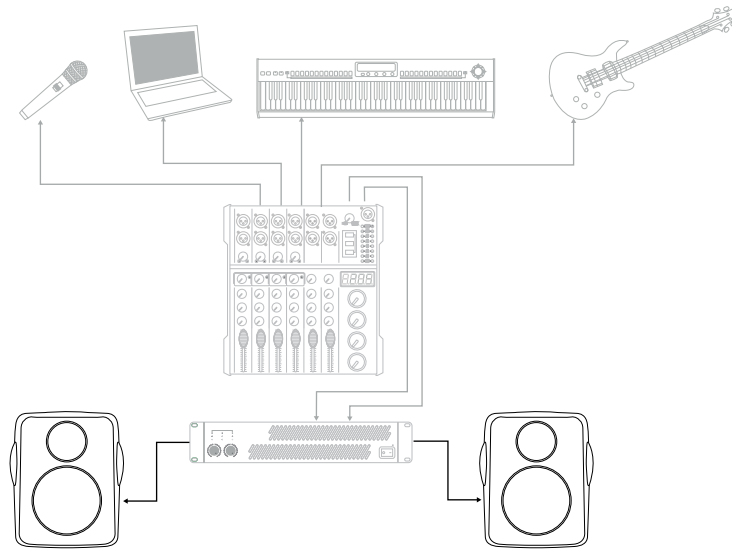

Achat 206

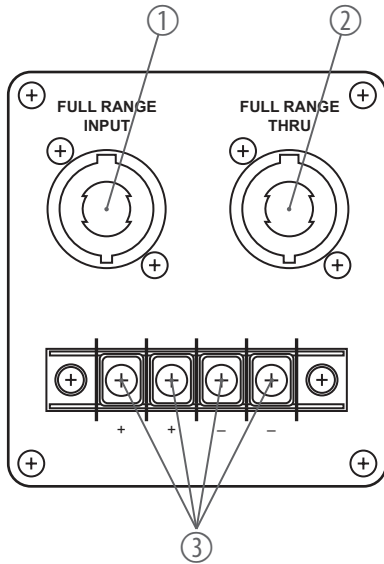

1, 2 NL4 connections wired in parallel

3 Screw terminals (2 × 2-pin) with cover for contact protection

5 Technical specifications

	the box pro Achat 206 (item no. 277560)	the box pro Achat 206 WH (item no. 277958)
System	2-way full-range box with built-in crossover	
Speaker	2 × 6" woofer, 1 × 1" compression tweeter	
Input connections	1 × lockable NL4 socket (1+/1-) (Speaker Twist)	
	Screw terminals (2 × 2-pin) with cover for contact protection	
Output connector	1 × lockable NL4 socket (1+/1-) (Speaker Twist)	
Sound pressure level (SPL) max.	122 dB	
Frequency range	70 Hz ... 20 kHz, -3 dB	
Load capacity	250 W (RMS), 1000 W (peak)	
Sensitivity (1 W/1 m)	95.5 dB	
Rated impedance	8 Ω	

Technical specifications

Dispersion angle (H × V)		90° × 90°	
Dimensions (W × H × D)		200 mm × 223.7 mm × 568 mm	
Weight		12 kg	
Surface		black textured paint	white textured paint
Ambient conditions	Temperature range	0 °C...40 °C	
	Relative humidity	20 %...80 % (non-condensing)	

Frequency response

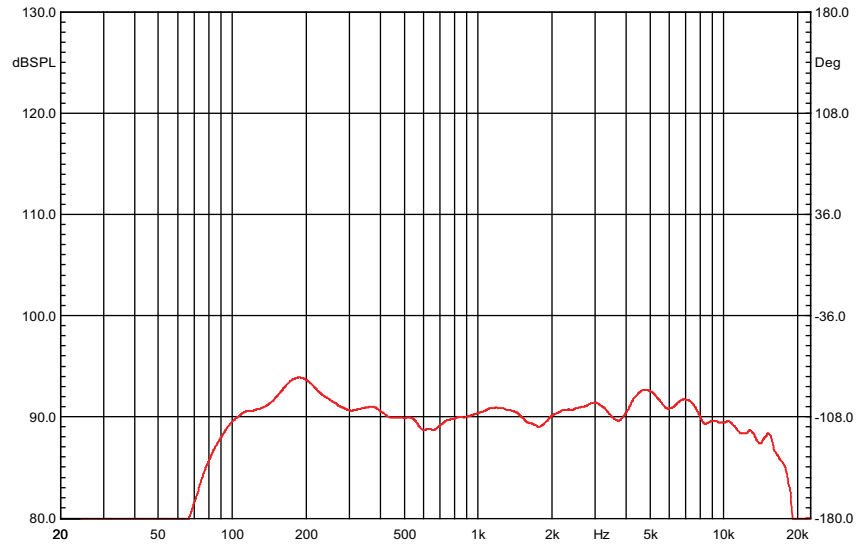

Achat 206

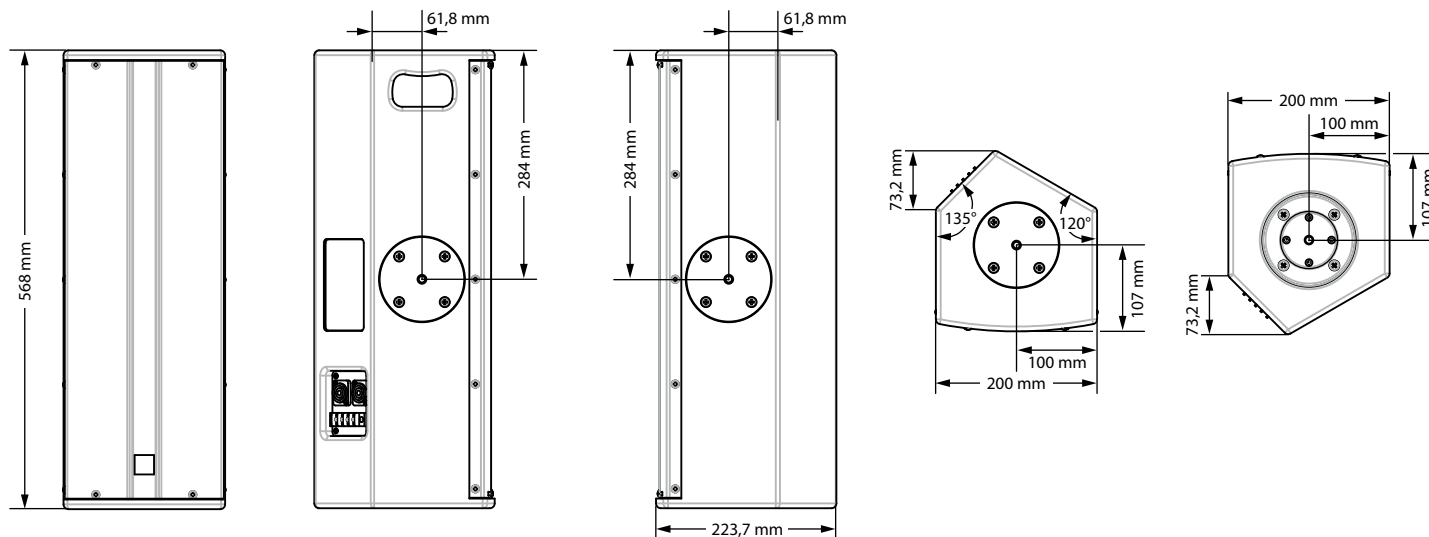

Further information

Cover	Optionally available (item no. 385906)
Construction	Column
Monitor wedge	Yes
Weatherproof	No
Housing	Wood
Stand flange	36 mm
Truss-capable	Yes, M10

6 Plug and connection assignment

Introduction

This chapter will help you select the right cables and plugs to connect your valuable equipment in such a way that a perfect sound experience is ensured.

Please note these advices, because especially in 'Sound & Light' caution is indicated: Even if a plug fits into the socket, an incorrect connection may result in a destroyed power amp, a short circuit or 'just' in poor transmission quality!

Speaker Twist chassis connector

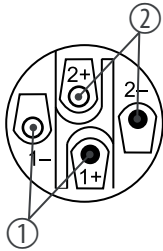

1, +	Signal 1 (in phase)
1, -	Signal 1 (out of phase)
2, +	Signal 2 (in phase)
2, -	Signal 2 (out of phase)

7 Protecting the environment

Disposal of the packaging material



For the transport and protective packaging, environmentally friendly materials have been chosen that can be supplied to normal recycling.

Ensure that plastic bags, packaging, etc. are properly disposed of.

Do not just dispose of these materials with your normal household waste, but make sure that they are collected for recycling. Please follow the notes and markings on the packaging.

Disposal of your old device



This product is subject to the European Waste Electrical and Electronic Equipment Directive (WEEE) in its currently valid version. Do not dispose with your normal household waste.

Dispose of this device through an approved waste disposal firm or through your local waste facility. When discarding the device, comply with the rules and regulations that apply in your country. If in doubt, consult your local waste disposal facility.



Musikhaus Thomann · Hans-Thomann-Straße 1 · 96138 Burgebrach · Germany · www.thomann.de