



  
STAIRVILLE

Outdoor Stage PAR  
12 × 4 W Quad,  
12 × 3 W UV IR

LED PAR

Musikhaus Thomann  
Thomann GmbH  
Hans-Thomann-Straße 1  
96138 Burgebrach  
Germany  
Telephone: +49 (0) 9546 9223-0  
E-mail: [info@thomann.de](mailto:info@thomann.de)  
Internet: [www.thomann.de](http://www.thomann.de)

16.08.2021, ID: 387911, 387902 (V7)

# Table of contents

<b>1</b>	<b>General information</b> .....	<b>5</b>
	1.1 Further information.....	6
	1.2 Notational conventions.....	7
	1.3 Symbols and signal words.....	8
<b>2</b>	<b>Safety</b> .....	<b>11</b>
<b>3</b>	<b>Features</b> .....	<b>16</b>
<b>4</b>	<b>Installation</b> .....	<b>18</b>
<b>5</b>	<b>Starting up</b> .....	<b>23</b>
<b>6</b>	<b>Connections and controls</b> .....	<b>26</b>
<b>7</b>	<b>Operating</b> .....	<b>32</b>
	7.1 Operating mode 'Auto Run Mode'.....	33
	7.2 Operating mode 'Manual' (only 12×4W Quad IR RGBW).....	34
	7.3 Operating mode 'Static Colour' (12×4W Quad IR RGBW).....	37
	7.4 Operating mode 'Static Colour' (12×3W Quad IR UV).....	38
	7.5 Operating mode 'DMX' (12×4W Quad IR RGBW).....	39

7.6	Operating mode 'DMX' (12×3W Quad IR UV).....	44
7.7	Operating mode 'Slave'.....	47
7.8	Remote control (optional, 12×4W Quad IR RGBW).....	47
7.9	Remote control (optional, 12×3W Quad IR UV).....	50
<b>8</b>	<b>Technical specifications.....</b>	<b>52</b>
<b>9</b>	<b>Plug and connection assignments.....</b>	<b>56</b>
<b>10</b>	<b>Troubleshooting.....</b>	<b>57</b>
<b>11</b>	<b>Cleaning.....</b>	<b>59</b>
<b>12</b>	<b>Protecting the environment.....</b>	<b>60</b>

# 1 General information

This user manual contains important information on the safe operation of the device. Read and follow all safety notes and all instructions. Save this manual for future reference. Make sure that it is available to all persons using this device. If you sell the device to another user, be sure that they also receive this manual.

Our products and user manuals are subject to a process of continuous development. We therefore reserve the right to make changes without notice. Please refer to the latest version of the user manual which is ready for download under [www.thomann.de](http://www.thomann.de).

## 1.1 Further information

On our website ([www.thomann.de](http://www.thomann.de)) you will find lots of further information and details on the following points:

Download	This manual is also available as PDF file for you to download.
Keyword search	Use the search function in the electronic version to find the topics of interest for you quickly.
Online guides	Our online guides provide detailed information on technical basics and terms.
Personal consultation	For personal consultation please contact our technical hotline.
Service	If you have any problems with the device the customer service will gladly assist you.

## 1.2 Notational conventions

This manual uses the following notational conventions:

### Letterings

The letterings for connectors and controls are marked by square brackets and italics.

**Examples:** *[VOLUME]* control, *[Mono]* button.

### Displays

Texts and values displayed on the device are marked by quotation marks and italics.

**Examples:** *'24ch'*, *'OFF'*.

### Instructions

The individual steps of an instruction are numbered consecutively. The result of a step is indented and highlighted by an arrow.



#### Example:



1. ▶ Switch on the device.
2. ▶ Press *[Auto]*.
  - ⇒ Automatic operation is started.
3. ▶ Switch off the device.

## 1.3 Symbols and signal words

In this section you will find an overview of the meaning of symbols and signal words that are used in this manual.



Signal word	Meaning
<b>DANGER!</b>	This combination of symbol and signal word indicates an immediate dangerous situation that will result in death or serious injury if it is not avoided.
<b>WARNING!</b>	This combination of symbol and signal word indicates a possible dangerous situation that can result in death or serious injury if it is not avoided.
<b>NOTICE!</b>	This combination of symbol and signal word indicates a possible dangerous situation that can result in material and environmental damage if it is not avoided.
Warning signs	Type of danger
	Warning – high-voltage.
	Warning – hot surface.

Warning signs	Type of danger
	Warning – dangerous optical radiation.
	Warning – suspended load.
	Warning – danger zone.

## 2 Safety

### Intended use

This device is intended for use as an electronic lighting effect by means of LED technology. The device is designed for professional use and is not suitable for use in households. Use the device only as described in this user manual. Any other use or use under other operating conditions is considered to be improper and may result in personal injury or property damage. No liability will be assumed for damages resulting from improper use.

This device may be used only by persons with sufficient physical, sensorial, and intellectual abilities and having corresponding knowledge and experience. Other persons may use this device only if they are supervised or instructed by a person who is responsible for their safety.

Extend the life of the device by regular breaks in operation and avoid switching it on and off frequently. This device is not suitable for continuous use.

## Safety



### **DANGER!**

#### **Danger for children**

Ensure that plastic bags, packaging, etc. are disposed of properly and are not within reach of babies and young children. Choking hazard!

Ensure that children do not detach any small parts (e.g. knobs or the like) from the unit. They could swallow the pieces and choke!

Never let children unattended use electrical devices.



### **DANGER!**

#### **Electric shock caused by short-circuit**

Do not modify the mains cable or the plug. Failure to do so could result in electric shock/death or fire. If in doubt, seek advice from a registered electrician.

**DANGER!****Electric shock caused by high voltages inside**

Within the device there are areas where high voltages may be present. Never remove any covers.

There are no user-serviceable parts inside.

Do not use the device if covers, protectors or optical components are missing or damaged.

**WARNING!****Eye damage caused by high light intensity**

Never look directly into the light source.

**WARNING!****Risk of epileptic shock**

Strobe lighting can trigger seizures in photosensitive epilepsy. Sensitive persons should avoid looking at strobe lights.

**WARNING!****Risk of burns**

The surface of the device can become very hot during operation.

Do not touch the device with bare hands during operation, and after switching off wait for at least 15 minutes.

**NOTICE!****Risk of fire**

Do not block areas of ventilation. Do not install the device near any direct heat source. Keep the device away from naked flames.

**NOTICE!****Power supply**

Before connecting the device, ensure that the input voltage (AC outlet) matches the voltage rating of the device and that the AC outlet is protected by a residual current circuit breaker. Failure to do so could result in damage to the device and possibly injure the user.

Unplug the device before electrical storms occur and when it is unused for long periods of time to reduce the risk of electric shock or fire.

### 3 Features

Due to its sturdy and weather-proof housing made of die-cast aluminium, the Outdoor Stage PAR is specially designed for outdoor use. The very bright UV or quad-colour LEDs make it particularly suitable for professional lighting tasks.

- LED configuration:
  - **Outdoor Stage PAR 12x4W Quad IR RGBW** with 12 Quad-Color LEDs
  - **Outdoor Stage PAR 12x3W Quad IR UV** with 12 UV LEDs
- Control via DMX (3 different modes), buttons and display on the unit or via IR remote control (optional, not included)
- Preprogrammed automatic shows
- Master / Slave operation
- rugged die-cast aluminium housing
- Degree of protection IP65 (suitable for outdoor use)
- Splashproof safety plug (IP44)
- Pressure compensation element (prevents condensation inside the device)
- Connectors for power supply and DMX control via splashproof screw-mountable plugs and couplings
- sturdy double bracket for secure attachment to trusses or firm footing on the ground



For technological reasons, the light output of LEDs decreases over their lifetime. This effect increases with higher operating temperature. You can extend the service life of the illuminants by providing adequate ventilation and operating the LEDs with the lowest possible brightness.

### **Information about protection class IP65**

Equipment with protection class IP65 are dust-tight and completely protected against contact (first code number). They are also protected against splash water from any angle (second code digit). That is why this equipment can also be used outdoors. Event technology equipment is generally only designed for temporary use however (event lighting) and not for permanent use outdoors.

The specified protection class does not make a statement about the weather resistance of the equipment (resistance to changing ambient conditions as well as against the effects of sunlight and UV rays).

The seals and screw connections of the equipment must be checked regularly to ensure a fault-free operation. In cases of doubt, consult a specialist workshop in due time.

## 4 Installation

Unpack and check carefully there is no transportation damage before using the unit. Keep the equipment packaging. To fully protect the product against vibration, dust and moisture during transportation or storage use the original packaging or your own packaging material suitable for transport or storage, respectively.



**WARNING!**

**Risk of injury caused by falling objects**

Make sure that the installation complies with the standards and rules that apply in your country. Always secure the device with a secondary safety attachment, such as a safety cable or a safety chain.



**NOTICE!**

**Risk of overheating**

Always ensure sufficient ventilation.

The ambient temperature must not exceed the limits stated in the chapter Technical Specifications of the User Manual.



**NOTICE!**

**Use of stands**

When mounting the device onto a stand, ensure that the stand is in a safe and stable position and that the weight of the device does not exceed the maximum permissible load capacity of the stand.



### **NOTICE!**

#### **Possible data transmission errors**

For error-free operation make use of dedicated DMX cables and do not use ordinary microphone cables.

Never connect the DMX input or output to audio devices such as mixers or amplifiers.



### **NOTICE!**

#### **Possible damage due to moisture**

Moisture entering into open connectors (plugs and couplers) of DMX or power cords can cause short circuits.

Close unused connectors with end caps intended for this purpose ([www.thomann.de](http://www.thomann.de)).

## **Mounting options**

You can install the unit in hanging or standing position. When in use, the device must always be attached to a solid surface or an approved truss. Use the openings provided on the two-piece bracket for attaching.

Always work from a stable platform whenever installing, moving or servicing the unit. In doing so, the area underneath the unit must be cordoned off.

The safety cable must be attached to the safety eyelet.



*Please note that this device must not be connected to a dimmer.*

## Connecting the DMX IP65 connectors

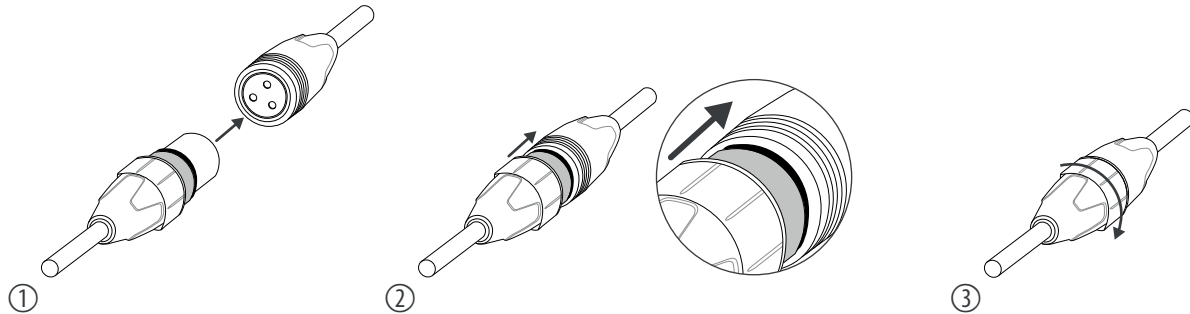

Proceed as follows to connect the DMX-IP65 connectors:

1. ➤ Insert the plug completely and straight into the coupling.
2. ➤ Make sure that the flexible sealing ring has complete contact.
3. ➤ Turn the union nut straight onto the thread of the coupling. Hand-tighten the union nut.

## 5 Starting up

Create all connections while the device is off. Use the shortest possible high-quality cables for all connections. Take care when running the cables to prevent tripping hazards.

### Connections in DMX mode

Connect the DMX input of the device to the DMX output of a DMX controller or another DMX device. Connect the output of the first DMX device to the input of the second one, and so on to form a daisy chain. Always ensure that the output of the last DMX device in the daisy chain is terminated with a resistor ( $110\ \Omega$ ,  $\frac{1}{4}\ \text{W}$ ).

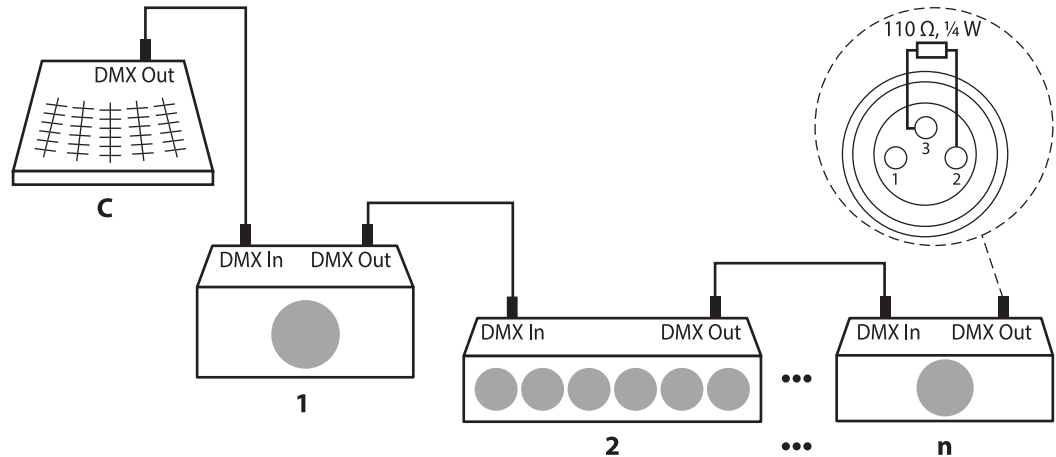



---

**Connections in 'Master / Slave' mode**

When you configure a group of devices in 'Master / Slave' mode, the first unit will control the others. This feature is especially useful to start a show without much programming. Connect the DMX output of the master unit to the DMX input of the first slave unit. Then connect the DMX output of the first slave unit to the DMX input of the second slave unit and so on.

## 6 Connections and controls

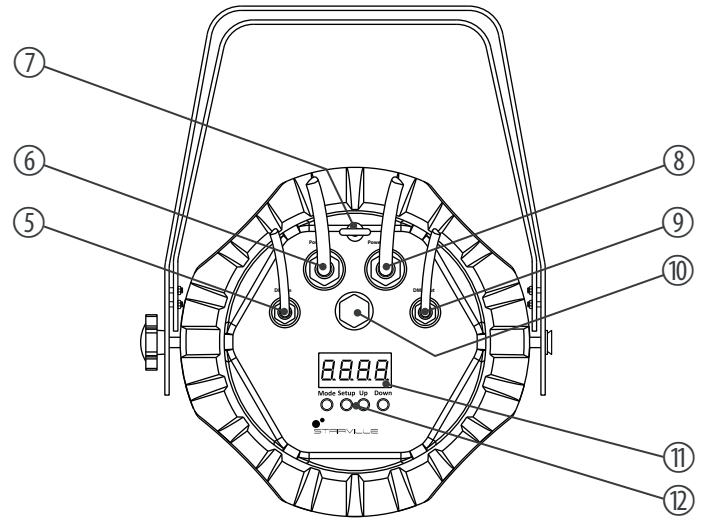
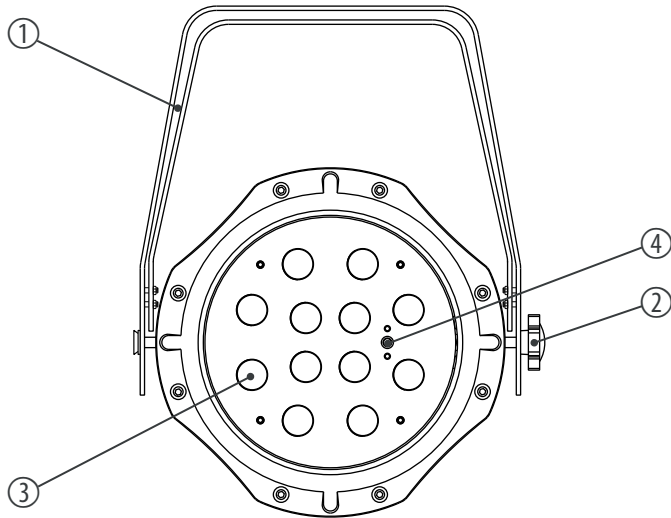

1	Two-piece bracket for hanging or installation and for securing the safety cable
2	Locking screws
3	LEDs
4	Infrared sensor for optionally available remote control
5	<i>[DMX IN]</i> DMX input cable
6	<i>[Power In]</i> Mains cable for the power supply of the device
7	Safety cable eyelet.
8	<i>[Power Out]</i> Power cord for the voltage supply of a connected device
9	<i>[DMX OUT]</i> DMX output cable
10	Pressure compensation element

11 Display

12 Control buttons

*[Mode]*: Activates the main menu and toggles between menu items.

*[Setup]*: Selects an option of the respective operating mode.

*[Up]*: Increases the displayed value by one.

*[Down]*: Decreases the displayed value by one.

Remote control (optional)

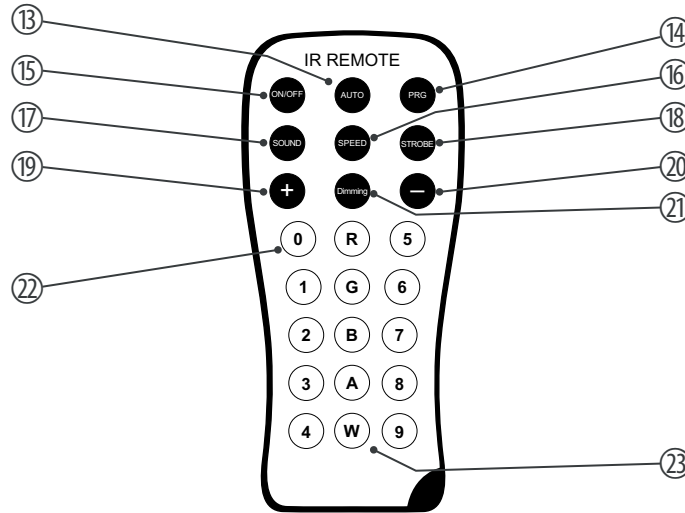

Outdoor Stage PAR 12 × 4 W Quad, 12 × 3 W UV IR

13	<i>[AUTO]</i> Activates the 'Automatic' mode.
14	<i>[PRG]</i> Activates the operating mode 'Preprogrammed automatic show'. Select the desired programme with <i>[+]</i> and <i>[-]</i> .
15	<i>[ON/OFF]</i> Activates / deactivates the device.
16	<i>[SPEED]</i> Activates the setting mode for the programme speed. Adjust the speed using <i>[+]</i> and <i>[-]</i> .
17	<i>[SOUND]</i> No function.
18	<i>[STROBE]</i> Turns the strobe effect on / off.
19	<i>[+]</i> Increases the set value.

20	<i>[-]</i> Decreases the set value.
21	<i>[Dimming]</i> Enables the dimmer function.
22	<i>[0 ... 9]</i> Numeric buttons for direct selection of a fixed colour.
23	<i>[R], [G], [B], [A], [W]</i> Buttons to select a colour tone for the dimmer mode.

## 7 Operating

Connect the device to the power supply to start operation. After a few seconds, the display indicates that a reset is in progress. The device is then ready for use.

Press *[Mode]* to activate the main menu and select an operating mode. Use *[Setup]* to select further options. Use *[Up]* and *[Down]* to change the respectively indicated value. The unit instantly applies the displayed value, you don't need to push a button for confirmation.

If you don't press any button for about 20 seconds, the current setting will be automatically applied and the display turns off. The set values are retained as long as the device is connected to the mains power supply.



## 7.1 Operating mode 'Auto Run Mode'

In automatic mode, all programmed shows are played sequentially in an endless loop.

A preprogrammed automatic show can only be activated when the unit is operating in stand-alone mode or as master in a master / slave combination. This setting is only relevant if the device is not controlled via DMX.

➔ Press *[Mode]*, use *[Up]* and *[Down]* to select the menu option 'Auto' and confirm with *[Setup]*.

## 7.2 Operating mode 'Manual' (only 12×4W Quad IR RGBW)

This operating mode can only be activated when the unit is operating in stand alone mode or as master in a master / slave combination. This setting is only relevant if the device is not controlled via DMX.

1. ➤ Press *[Mode]*, use *[Up]* and *[Down]* to select the menu option 'Pro' and confirm with *[Setup]*.
2. ➤ Use *[Up]* and *[Down]* to select the desired programme (01 ... 07) and confirm with *[Setup]*.

**Settings for program 01**

When you have selected programme 01, you can use *[Setup]* to access the settings. Now use *[Up]* and *[Down]* to select one of 15 static colour settings for all LEDs, see the following chart.

<b>Colour</b>	<b>Display</b>
Cyan	'00'
Purple	'01'
Pink	'02'
Orange	'03'
Cold white	'04'
Bright red	'05'
Bright green	'06'
Bright blue	'07'
Yellow	'08'
Warm white	'09'

<b>Colour</b>	<b>Display</b>
Red	'10'
Green	'11'
Blue	'12'
Amber	'13'
All	'14'
Blackout	'15'

## Settings for programmes 02 ... 07

When you have selected one of programmes 02 ... 07 you can adjust the following settings:

1. ➤ After selecting the programme, press again *[Setup]* and adjust the programme speed with *[Up]* and *[Down]* in a range from 'SP.01' ... 'SP.FL' (slow ... fast) and confirm with *[Setup]*.
2. ➤ Press again *[Setup]* and adjust the frequency of the strobe effect with *[Up]* and *[Down]* in a range from 'F5.00' ... 'F5.99' (slow ... fast) and confirm with *[Setup]*.

## 7.3 Operating mode 'Static Colour' (12×4W Quad IR RGBW)

This setting is only relevant if the device is working in Stand Alone mode and is not controlled via DMX. In this mode you have the option to select a solid colour for continuous operation and to set the flash frequency for all LEDs.

1. ➤ Press *[Mode]*, use *[Up]* and *[Down]* to select the menu option 'Colr' and confirm with *[Setup]*.
2. ➤ Use *[Up]* and *[Down]* to set the intensity for the red colour in a range from 'r.000' ... 'r.255' (bright ... dark) and confirm with *[Setup]*.

3. ➤ Use *[Up]* and *[Down]* to set the intensity for the green colour in a range from 'g.000' ... 'g.255' (bright ... dark) and confirm with *[Setup]*.
4. ➤ Use *[Up]* and *[Down]* to set the intensity for the blue colour in a range from 'b.000' ... 'b.255' (bright ... dark) and confirm with *[Setup]*.
5. ➤ Use *[Up]* and *[Down]* to set the intensity for the white colour in a range from 'u.000' ... 'u.255' (bright ... dark) and confirm with *[Setup]*.
6. ➤ Use *[Up]* and *[Down]* to set the frequency of the strobe effect in a range from 'F5.00' ... 'F5.99' (off, slow ... fast) and confirm with *[Setup]*.

### 7.4 Operating mode 'Static Colour' (12×3W Quad IR UV)

This setting is only relevant if the device is working in Stand Alone mode and is not controlled via DMX. In this mode you have the option to select a solid colour for continuous operation and to set the flash frequency for all LEDs.

1. ➤ Press *[Mode]*, use *[Up]* and *[Down]* to select the menu option 'Colr' and confirm with *[Setup]*.
2. ➤ Use *[Up]* and *[Down]* to set the brightness of the LEDs in a range from 'l.000' ... 'l.255' (bright ... dark) and confirm with *[Setup]*.

3. Use *[Up]* and *[Down]* to set the frequency of the strobe effect in a range from 'F5.00' ... 'F5.99' (off, slow ... fast) and confirm with *[Setup]*.

## 7.5 Operating mode 'DMX' (12×4W Quad IR RGBW)

This setting is only relevant if the device is controlled via a DMX controller.

1. Press *[Mode]*, use *[Up]* and *[Down]* to select the menu option 'DMX' and confirm with *[Setup]*.
2. Use *[Up]* and *[Down]* to assign a DMX address in the range from 'd.001' ... 'd.512' to the device and confirm with *[Setup]*.
3. Use *[Up]* and *[Down]* to select the desired DMX mode:

Mode	Display	Highest possible DMX address
4-channel	'4-ch'	509
6-channel	'6-ch'	507
8-channel	'8-ch'	505

4. ➤ Confirm twice with *[Setup]*.

### 7.5.1 Functions in 4-channel DMX mode

Channel	Value	Function
1	0...255	Intensity red (0 % to 100 %)
2	0...255	Intensity green (0 % to 100 %)
3	0...255	Intensity blue (0 % to 100 %)
4	0...255	Intensity white (0 % to 100 %)

### 7.5.2 Functions in 6-channel DMX mode

Channel	Value	Function
1	0...255	Dimmer (0 % to 100 %)
2	0...255	Intensity red (0 % to 100 %)



Channel	Value	Function
3	0...255	Intensity green (0 % to 100 %)
4	0...255	Intensity blue (0 % to 100 %)
5	0...255	Intensity white (0 % to 100 %)
6	19...255	Stroboscope effect (0 % to 100 %)

### 7.5.3 Functions in 8-channel DMX mode

Channel	Value	Function
1	0 ... 255	Dimmer (0 % to 100 %)
2	0 ... 255	Intensity red (0 % to 100 %), if channel 6 = 0 ... 35
3	0 ... 255	Intensity green (0 % to 100 %), if channel 6 = 0 ... 35
4	0 ... 255	Intensity blue (0 % to 100 %), if channel 6 = 0 ... 35
5	0 ... 255	Intensity white (0 % to 100 %), if channel 6 = 0 ... 35

Channel	Value	Function
6	Programme selection	
	0 ... 35	No function
	36 ... 71	Programme 01
	72 ... 107	Programme 02
	108 ... 143	Programme 03
	144 ... 179	Programme 04
	180 ... 215	Programme 05
	216 ... 251	Programme 06
	252 ... 255	Programme 07
7	Colour selection, if channel 6 = 36 ... 71	
	Speed, if channel 6 = 72 ... 255	
	0 ... 16	Blackout
	17 ... 33	Cyan

Channel	Value	Function
	34 ... 50	Purple
	51 ... 67	Pink
	68 ... 84	Orange
	85 ... 101	Cold white
	102 ... 118	Light red
	119 ... 135	Light green
	136 ... 152	Light blue
	153 ... 169	Yellow
	170 ... 186	Warm white
	187 ... 203	Red
	204 ... 220	Green
	221 ... 237	Blue
	238 ... 254	Amber

Outdoor Stage PAR 12 × 4 W Quad, 12 × 3 W UV IR

Channel	Value	Function
	255	All
	0 ... 255	Programme progress speed
8	19 ... 255	Strobe effect

## 7.6 Operating mode 'DMX' (12×3W Quad IR UV)

This setting is only relevant if the device is controlled via a DMX controller.

1. ➤ Press *[Mode]*, use *[Up]* and *[Down]* to select the menu option 'DMX' and confirm with *[Setup]*.
2. ➤ Use *[Up]* and *[Down]* to assign a DMX address in the range from 'd.001' ... 'd.512' to the device and confirm with *[Setup]*.

3. ▶ Use *[Up]* and *[Down]* to select the desired DMX mode:

Mode	Display	Highest possible DMX address
1-channel	'1-ch'	512
2-channel	'2-ch'	511
5-channel	'5-ch'	508

4. ▶ Confirm twice with *[Setup]*.

### 7.6.1 Functions in 1-channel DMX mode

Channel	Value	Function
1	0...255	Intensity UV light (0 % to 100 %)

## 7.6.2 Functions in 2-channel DMX mode

Channel	Value	Function
1	0...255	Intensity UV light (0 % to 100 %)
2	0...255	Stroboscope effect (0 % to 100 %)

## 7.6.3 Functions in 5-channel DMX mode

Channel	Value	Function
1	0 ... 255	Dimmer (0 % to 100 %)
2	0 ... 255	Intensity UV light (0 % to 100 %)
3	10 ... 255	Fade in / out
4	0 ... 255	Programme speed (0 % to 100 %)
5	19 ... 255	Stroboscope effect (0 % to 100 %)

## 7.7 Operating mode 'Slave'

This setting is only relevant if the device is working as Slave in a Master / Slave configuration and is not controlled via DMX. To activate the operating mode, repeatedly press *[Mode]* until the display shows 'SLAV'.

## 7.8 Remote control (optional, 12×4W Quad IR RGBW)

The device can only be remote controlled if it's neither working in a Master / Slave configuration nor DMX-controlled.

### Switching on / off

Use *[ON/OFF]* to turn the device on or off.

### Operating mode 'Automatic'

Press *[AUTO]*. The playback of programmes 'Pr02' to 'Pr14' starts automatically.

### **Operating mode 'Preprogrammed automatic show'**

Press *[PRO]*. Use *[+]* and *[-]* to select a value between 'Pr01' and 'Pr07'.

In the 'Preprogrammed automatic show' mode, you can activate the strobe effect. To do so, press *[STROBE]* and then use *[+]* and *[-]* to select a value between 'FS00' (slow) and 'FS99' (fast). Press *[STROBE]* again to disable the Strobe effect.

### **Dimming**

Press *[Dimming]* to adjust the brightness of the primary colours. Press *[R]* (red), *[G]* (green) *[W]* (white) or *[B]* (blue) and then use *[+]* and *[-]* to select a value between 0 and 255.



**Colour selection**

You can use the coloured buttons to directly select a colour for programmes 'Pr01' and 'Pr09'. The following assignment applies:

Button	Colour	Button	Colour	Button	Colour
0	Cyan	5	Bright red	R	Red
1	Purple	6	Bright green	G	Green
2	Magenta	7	Bright blue	B	Blue
3	Orange	8	Yellow	A	Amber
4	Cold white	9	Warm white	W	White

**Resetting to factory defaults**

To reset the device to factory default settings, press [OFF] and the successively [9], [8] and [7].

## 7.9 Remote control (optional, 12×3W Quad IR UV)

The device can only be remote controlled if it's neither working in a Master / Slave configuration nor DMX-controlled.

### Switching on / off

Use *[ON/OFF]* to turn the device on or off.

### Operating mode 'Automatic'

Press *[AUTO]*. The playback of the programmes starts automatically.

Press *[SPEED]* and use *[+]* and *[-]* to set the programme speed in a range from 'SP01' (slow) to 'SPFL' (fast).

Press *[STROBE]* and use *[+]* and *[-]* to set the flash frequency in a range from 'FS00' (slow) to 'FS99' (fast). Press *[STROBE]* again to disable the Strobe effect.

### Dimming

Press *[Dimming]* and set the brightness of the LED with *[+]* and *[-]* in a range from '1.000' to '1.255'.

**Resetting to factory defaults**

To reset the device to factory default settings, press *[OFF]* and the successively *[9]*, *[8]* and *[7]*.

## 8 Technical specifications

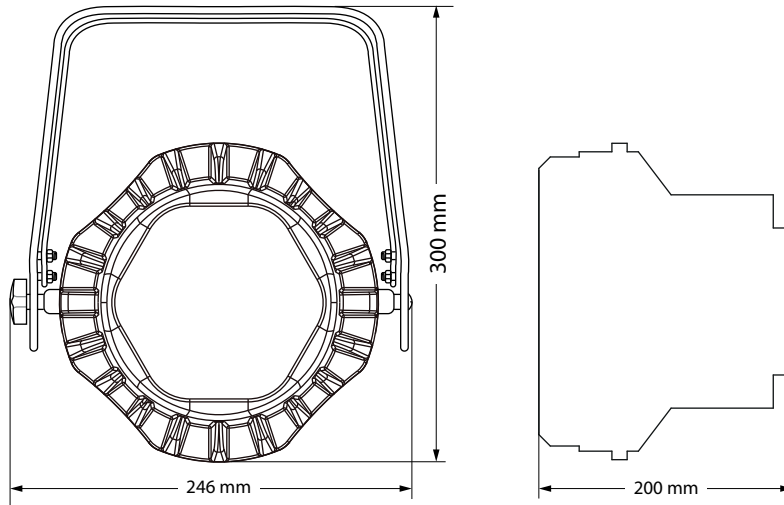

		<b>Outdoor Stage Par 12×4W Quad IR RGBW Item no. 387902</b>	<b>Outdoor Stage Par 12×3W Quad IR UV Item no. 387911</b>
Light source		12 × Quad IR RGBW LED, 4 W	12 × Quad IR UV LED, 3 W
Optical properties	Beam angle	25°	25°
Control	DMX		
	IR remote (optional)		
Number of DMX channels		4, 6, 8	1, 2, 5
Input connections	Power supply	Power cable with IP65 screw connector	
	DMX control	DMX cable with IP65 XLR plug, 3-pin	
Output connections	Power supply	Power cable with IP65 screw connector	
	DMX control	DMX cable with IP65 XLR socket, 3-pin	
Power consumption		61 W	47 W
Supply voltage		110 – 240 V ~ 50/60 Hz	

Outdoor Stage PAR 12 × 4 W Quad, 12 × 3 W UV IR

		<b>Outdoor Stage Par 12×4W Quad IR RGBW Item no. 387902</b>	<b>Outdoor Stage Par 12×3W Quad IR UV Item no. 387911</b>
Degree of protection		IP65	
Mounting options		Hanging, standing	
Dimensions (W × H × D)		246 mm × 300 mm × 200 mm	
Weight		3.5 kg	
Ambient conditions	Temperature range	-20 °C ... +40 °C	
	Relative humidity	50 %, non-condensing	

**Further information**

	<b>Outdoor Stage Par 12×4W Quad IR RGBW Item no. 387902</b>	<b>Outdoor Stage Par 12×3W Quad IR UV Item no. 387911</b>
Outdoor housing design	Studio housing	Studio housing
Colour mixture	UV	UV
LED type	Unicoloured LEDs	Unicoloured LEDs
Base housing	Yes	Yes
Fanless	Yes	Yes
Remote control	Optional	Optional
Wireless DMX	No	No
Housing colour	Black	Black

Outdoor Stage PAR 12 × 4 W Quad, 12 × 3 W UV IR

## 9 Plug and connection assignments

### Introduction

This chapter will help you select the right cables and plugs to connect your valuable equipment so that a perfect light experience is guaranteed.

Please take our tips, because especially in 'Sound & Light' caution is indicated: Even if a plug fits into a socket, the result of an incorrect connection may be a destroyed DMX controller, a short circuit or 'just' a not working light show!

### DMX connections



The unit offers a 3-pin XLR socket for DMX output and a 3-pin XLR plug for DMX input. Please refer to the drawing and table below for the pin assignment of a suitable XLR plug.

Pin	Configuration
1	Ground, shielding
2	Signal inverted (DMX-, 'cold signal')
3	Signal (DMX+, 'hot signal')



## 10 Troubleshooting



### **NOTICE!**

#### **Possible data transmission errors**

For error-free operation make use of dedicated DMX cables and do not use ordinary microphone cables.

Never connect the DMX input or output to audio devices such as mixers or amplifiers.

In the following we list a few common problems that may occur during operation. We give you some suggestions for easy troubleshooting:

Symptom	Remedy
The unit does not work, no light.	Check the mains connection and the fuse.
No response to the DMX controller.	1. Check the DMX ports and cables for proper connection.
	2. Check the address settings and the DMX polarity.
	3. Try using another DMX controller.
	4. Check to see if the DMX cables run near or alongside to high voltage cables that may cause damage or interference to DMX interface circuits.

If the procedures recommended above do not succeed, please contact our Service Center. You can find the contact information at [www.thomann.de](http://www.thomann.de).

## 11 Cleaning

### Optical lenses

Clean the optical lenses, that are accessible from the outside, regularly in order to optimize the light output. The frequency of cleaning depends on the operating environment: wet, smoky or particularly dirty surroundings can cause more accumulation of dirt on the optics of the device.

- Clean with a soft cloth using our lamp and lens cleaner (item no. 280122).
- Always dry the parts carefully.

## 12 Protecting the environment

### Disposal of the packaging material



For the transport and protective packaging, environmentally friendly materials have been chosen that can be supplied to normal recycling.

Ensure that plastic bags, packaging, etc. are properly disposed of.

Do not just dispose these materials with your normal household waste, but make sure that they are fed to a recovery. Please follow the notes and markings on the packaging.

### Disposal of batteries



Batteries must not be disposed of as domestic waste or thrown into fire. Dispose of the batteries according to national or local regulations regarding hazardous waste. To protect the environment, dispose of empty batteries at your retail store or at appropriate collection sites.

### Disposal of your old device



This product is subject to the European Waste Electrical and Electronic Equipment Directive (WEEE) in its currently valid version. Do not dispose with your normal household waste.

Dispose this device through an approved waste disposal firm or through your local waste facility. When discarding the device, comply with the rules and regulations that apply in your country. If in doubt, consult your local waste disposal facility.





Musikhaus Thomann · Hans-Thomann-Straße 1 · 96138 Burgebrach · Germany · [www.thomann.de](http://www.thomann.de)