



STAIRVILLE

CX-30 RGBW,
CX-30 RGBW BRS,
CX-30 RGBW WH,
CX-30 RGB WW Bk,
CX-30 RGB WW BRS

LED PAR

Musikhaus Thomann
Thomann GmbH
Hans-Thomann-Straße 1
96138 Burgebrach
Germany
Telephone: +49 (0) 9546 9223-0
E-mail: info@thomann.de
Internet: www.thomann.de

17.09.2021, ID: 467321, 469059, 469060, 469061, 467325, ... (V3)

Table of contents

1	General information	5
1.1	Further information.....	6
1.2	Notational conventions.....	7
1.3	Symbols and signal words.....	7
2	Safety instructions	10
3	Features	13
4	Installation	14
5	Starting up	18
6	Connections and operating elements	21
7	Operating	24
7.1	Starting the device.....	24
7.2	Main menu.....	24
7.3	Menu overview.....	31
7.4	Functions in 4-channel DMX mode.....	32
7.5	Functions in 6-channel DMX mode.....	33

CX-30 RGBW, CX-30 RGBW BRS, CX-30 RGBW WH, CX-30 RGB WW Bk,
CX-30 RGB WW BRS

th•mann
MUSIC IS OUR PASSION

7.6	Functions in 8-channel DMX mode.....	35
8	Technical specifications.....	37
9	Plug and connection assignments.....	41
10	Troubleshooting.....	42
11	Cleaning.....	44
12	Protecting the environment.....	45

1 General information

This user manual contains important information on the safe operation of the device. Read and follow all safety notes and all instructions. Save this manual for future reference. Make sure that it is available to all persons using this device. If you sell the device to another user, be sure that they also receive this manual.

Our products and user manuals are subject to a process of continuous development. We therefore reserve the right to make changes without notice. Please refer to the latest version of the user manual which is ready for download under www.thomann.de.

1.1 Further information

On our website (www.thomann.de) you will find lots of further information and details on the following points:

Download	This manual is also available as PDF file for you to download.
Keyword search	Use the search function in the electronic version to find the topics of interest for you quickly.
Online guides	Our online guides provide detailed information on technical basics and terms.
Personal consultation	For personal consultation please contact our technical hotline.
Service	If you have any problems with the device the customer service will gladly assist you.

1.2 Notational conventions

This manual uses the following notational conventions:

Letterings

The letterings for connectors and controls are marked by square brackets and italics.

Examples: *[VOLUME]* control, *[Mono]* button.



Displays



Texts and values displayed on the device are marked by quotation marks and italics.

Examples: *'24ch'*, *'OFF'*.

1.3 Symbols and signal words

In this section you will find an overview of the meaning of symbols and signal words that are used in this manual.

Signal word	Meaning
DANGER!	This combination of symbol and signal word indicates an immediate dangerous situation that will result in death or serious injury if it is not avoided.
WARNING!	This combination of symbol and signal word indicates a possible dangerous situation that can result in death or serious injury if it is not avoided.
NOTICE!	This combination of symbol and signal word indicates a possible dangerous situation that can result in material and environmental damage if it is not avoided.
Warning signs	Type of danger
	Warning – high-voltage.
	Warning – dangerous optical radiation.

Warning signs	Type of danger
	Warning – suspended load.
	Warning – danger zone.

CX-30 RGBW, CX-30 RGBW BRS, CX-30 RGBW WH, CX-30 RGB WW Bk,
CX-30 RGB WW BRS

2 Safety instructions

Intended use

This device is intended for use as an electronic lighting effect by means of LED technology. The device is designed for professional use only and is not suitable for use in households. Use the device only as described in this user manual. Any other use or use under other operating conditions is considered to be improper and may result in personal injury or property damage. No liability will be assumed for damages resulting from improper use.

This device may be used only by persons with sufficient physical, sensorial, and intellectual abilities and having corresponding knowledge and experience. Other persons may use this device only if they are supervised or instructed by a person who is responsible for their safety.



Extend the operating life of the device by regular breaks and by avoiding frequent switching on and off. The device is not suitable for continuous operation.

Safety



DANGER!

Danger for children

Ensure that plastic bags, packaging, etc. are disposed of properly and are not within reach of babies and young children. Choking hazard! Ensure that children do not detach any small parts (e.g. knobs or the like) from the unit. They could swallow the pieces and choke! Never let children unattended use electrical devices.



DANGER!

Electric shock caused by high voltages inside

Within the device there are areas where high voltages may be present. Never remove any covers. There are no user-serviceable parts inside. Do not use the device if covers, protectors or optical components are missing or damaged.



DANGER!

Electric shock caused by short-circuit

Do not modify the mains cable or the plug. Failure to do so could result in electric shock/death or fire. If in doubt, seek advice from a registered electrician.



WARNING!

Eye damage caused by high light intensity

Never look directly into the light source.

CX-30 RGBW, CX-30 RGBW BRS, CX-30 RGBW WH, CX-30 RGB WW Bk,
CX-30 RGB WW BRS



WARNING!

Risk of epileptic shock

Strobe lighting can trigger seizures in photosensitive epilepsy. Sensitive persons should avoid looking at strobe lights.



NOTICE!

Risk of fire

Do not block areas of ventilation. Do not install the device near any direct heat source. Keep the device away from naked flames.



NOTICE!

Operating conditions

This device has been designed for indoor use only. To prevent damage, never expose the device to any liquid or moisture. Avoid direct sunlight, heavy dirt, and strong vibrations. Only operate the device within the ambient conditions specified in the chapter 'Technical specifications' of this user manual. Avoid heavy temperature fluctuations and do not switch the device on immediately after it was exposed to temperature fluctuations (for example after transport at low outside temperatures). Dust and dirt inside can damage the unit. When operated in harmful ambient conditions (dust, smoke, nicotine, fog, etc.), the unit should be maintained by qualified service personnel at regular intervals to prevent overheating and other malfunction.



NOTICE!

Power supply

Before connecting the device, ensure that the input voltage (AC outlet) matches the voltage rating of the device and that the AC outlet is protected by a residual current circuit breaker. Failure to do so could result in damage to the device and possibly injure the user. Unplug the device before electrical storms occur and when it is unused for long periods of time to reduce the risk of electric shock or fire.

3 Features

The CX series brings all-new colour creations into the range of LED lights. The multi-chip LEDs provide an unprecedented colour mixing in all spectra. Pastel colours, vivid and vibrant colours and white tones can be displayed extremely precisely using the spotlights of the CX series.

Special features of the device:

- 18 × 4-in-1 quad colour LEDs High Power RGBW type (item no. 467321, 469061, 523385)
- 18 × 4-in-1 quad colour LEDs High Power RGB WW type (item no. 467325, 523387)
- Control via DMX (3 different modes) and via buttons and display on the unit
- Automatic mode and sound control
- Master / Slave operation
- Robust metal housing in the colours black (item no. 467321, 467325), brushed silver (item no. 469061, 523387) or white (item no. 523385)
- Also available in Tourpack 4 (black housing: item no. 469059, 523393; brushed silver housing: item no. 469060, 523394) with four spots CX-30 in a flight case.

For technological reasons, the light output of LEDs decreases over their lifetime. This effect increases with higher operating temperature. You can extend the service life of the illuminants by providing adequate ventilation and operating the LEDs with the lowest possible brightness.

CX-30 RGBW, CX-30 RGBW BRS, CX-30 RGBW WH, CX-30 RGB WW Bk,
CX-30 RGB WW BRS

4 Installation

Unpack and check carefully there is no transportation damage before using the unit. Keep the equipment packaging. To fully protect the product against vibration, dust and moisture during transportation or storage use the original packaging or your own packaging material suitable for transport or storage, respectively.



WARNING!

Risk of injury caused by falling objects

Make sure that the installation complies with the standards and rules that apply in your country. Always secure the device with a secondary safety attachment, such as a safety cable or a safety chain.



NOTICE!

Risk of overheating

The distance between light output and the illuminated surface must be more than 1.5 m (19.7in).

Provide sufficient ventilation.

The ambient temperature must always be below 40 °C (104 °F).



NOTICE!

Use of stands

When mounting the device onto a stand, ensure that the stand is in a safe and stable position and that the weight of the device does not exceed the maximum permissible load capacity of the stand.



NOTICE!

Possible data transmission errors

For error-free operation make use of dedicated DMX cables and do not use ordinary microphone cables.

Never connect the DMX input or output to audio devices such as mixers or amplifiers.

Mounting options

You can install the unit in hanging or standing position. When in use, the device must always be attached to a solid surface or an approved truss. Use the openings provided on the two-piece bracket for attaching.

Always work from a stable platform whenever installing, moving or servicing the unit. In doing so, the area underneath the unit must be cordoned off.

The safety cable must be attached to the bracket.



Please note that this device must not be connected to a dimmer.

CX-30 RGBW, CX-30 RGBW BRS, CX-30 RGBW WH, CX-30 RGB WW Bk,
CX-30 RGB WW BRS

5 Starting up

Create all connections while the device is off. Use the shortest possible high-quality cables for all connections. Take care when running the cables to prevent tripping hazards.

Connections in DMX mode

Connect the DMX input of the device to the DMX output of a DMX controller or another DMX device. Connect the output of the first DMX device to the input of the second one, and so on to form a daisy chain. Always ensure that the output of the last DMX device in the daisy chain is terminated with a resistor ($110\ \Omega$, $\frac{1}{4}\ \text{W}$).

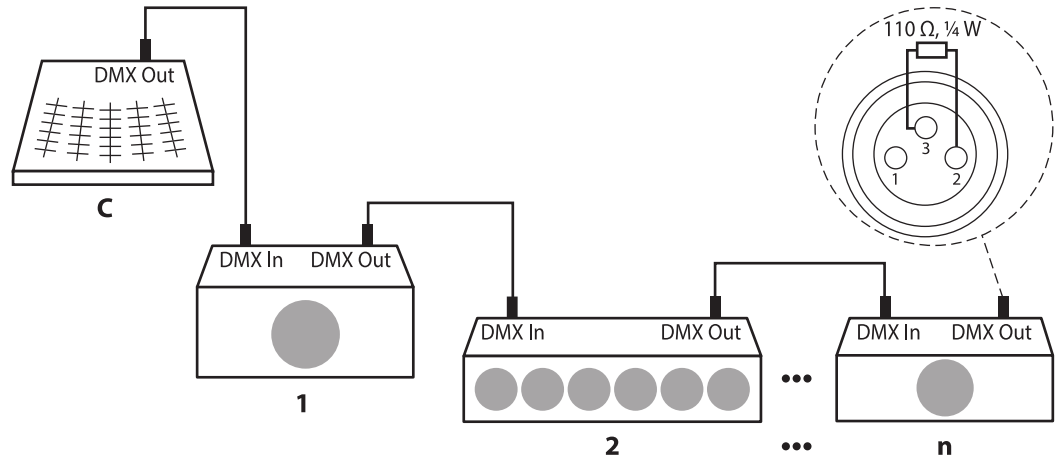

CX-30 RGBW, CX-30 RGBW BRS, CX-30 RGBW WH, CX-30 RGB WW Bk,
CX-30 RGB WW BRS

Connections in master/slave mode

When you configure a group of devices in master/slave mode, the first unit will control the other units for an automatic, sound-activated, synchronized show. This function is ideal when you want to start a show immediately. Connect the DMX output of the master device to the DMX input of the first slave device. Then connect the DMX output of the first slave device to the DMX input of the second slave device and so on.

6 Connections and operating elements

Rear panel

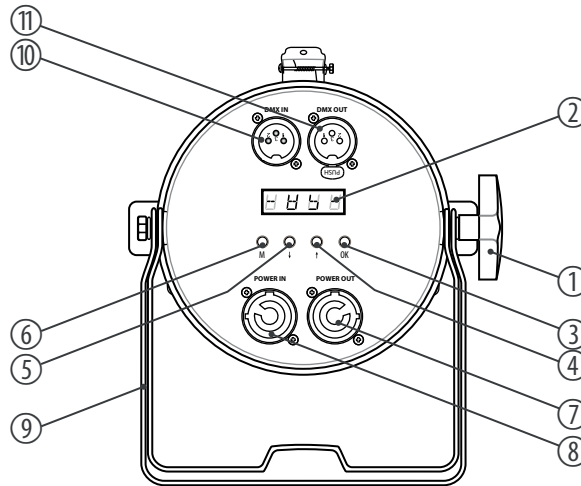

CX-30 RGBW, CX-30 RGBW BRS, CX-30 RGBW WH, CX-30 RGB WW Bk,
CX-30 RGB WW BRS

1	Locking screw for the bracket.
2	Display
3	<i>[OK]</i> Confirms a selected value
4	↑ Increases the displayed value by one
5	↓ Decreases the displayed value by one
6	<i>[M]</i> Calls up the main menu or a submenu
7	<i>[POWER OUT]</i> Lockable output socket (Power Twist)
8	<i>[POWER IN]</i> Lockable input socket (Power Twist)

9	Bracket for floor placement or hanging
10	<i>[DMX IN]</i> DMX input
11	<i>[DMX OUT]</i> DMX output

CX-30 RGBW, CX-30 RGBW BRS, CX-30 RGBW WH, CX-30 RGB WW Bk,
CX-30 RGB WW BRS

7 Operating

7.1 Starting the device

Connect the device to the power supply to start operation. After a few seconds, the display indicates that a reset is in progress. The device is then ready for use.

7.2 Main menu

Press *[M]* to activate the main menu. Use the arrow buttons to select an operation mode. When the display shows the desired value, press *[OK]*. Use the arrow buttons to change the respectively displayed value. When the display shows the desired value, press *[OK]*.

If you don't press any button for about 1 minute, the unit returns to the previously selected mode. The set values are retained even when the device is disconnected from the mains power supply.

DMX mode

Press *[M]*. Press one of the arrow buttons repeatedly until the display shows 'SET'. Press *[OK]*. Press one of the arrow buttons repeatedly until the display shows 'MODE'. Press *[OK]*. Now use the arrow buttons to select one of the following DMX modes:

- '4CH' (four channels)
- '6CH' (six channels)
- '8CH' (eight channels)

This setting is only relevant when the device is controlled via DMX. When the display shows the desired value press *[OK]* to confirm the selection and then *[M]* to return to the parent menu. To return to the parent menu without making changes, press *[M]*.

DMX address

Press *[M]*. Press one of the arrow buttons repeatedly until the display shows 'DMX'. Press *[OK]*. Now you can set the number of the first DMX channel to be used by the device (DMX address). Use the arrow buttons to select a value between 1 and 512 (display shows 'A001' ... 'A512').

When the display shows the desired value press *[OK]* to confirm the selection and then *[M]* to return to the parent menu. To return to the parent menu without making changes, press *[M]*.

Make sure that this number matches the configuration of your DMX controller. The following table shows the highest possible DMX address for the various DMX modes.

Mode	Highest possible DMX address
4-channel	509
6-channel	507
8-channel	505

Programme speed

Press *[M]*. Press one of the arrow buttons repeatedly until the display shows 'SET'. Press *[OK]*. Press one of the arrow buttons repeatedly until the display shows 'SPEE'. Press *[OK]*. Now you can adjust the programme speed for the preprogrammed automatic shows. Use the arrow buttons to select a value between 1 and 255 (display shows 'T001' ... 'T255').

This setting is only relevant if the device is not controlled via DMX. When the display shows the desired value press *[OK]* to confirm the selection and then *[M]* to return to the parent menu. To return to the parent menu without making changes, press *[M]*.

Microphone sensitivity

Press *[M]*. Press one of the arrow buttons repeatedly until the display shows 'SET'. Press *[OK]*. Press one of the arrow buttons repeatedly until the display shows 'MIC'. Press *[OK]*. Now you can adjust the sensitivity of the built-in microphone for sound control. Use the arrow buttons to select either 'OFF' (microphone off) or a value between 1 and 30 (display shows 'M-01' ... 'M-30').

This setting is only relevant if the device is not controlled via DMX. When the display shows the desired value press *[OK]* to confirm the selection and then *[M]* to return to the parent menu. To return to the parent menu without making changes, press *[M]*.

Operating mode 'Show/Master'

Press *[M]*. Press one of the arrow buttons repeatedly until the display shows 'LINE'. Press *[OK]*. Press one of the arrow buttons repeatedly until the display shows 'MA'. Press *[OK]*. Now you can select one of the preprogrammed automatic shows. Use the arrow buttons to select a value between 1 and 42 (display shows 'P-01' ... 'P-42').

The auto show can only be activated on the device that is configured as master.

This setting is only relevant if the device is not controlled via DMX. The device can operate in stand-alone mode or control connected devices of the same type, that must be configured as slaves. When the display shows the desired value press *[OK]* to confirm the selection and then *[M]* to return to the parent menu. To return to the parent menu without making changes, press *[M]*.

Operating mode 'Slave'

Press *[M]*. Press one of the arrow buttons repeatedly until the display shows 'LINE'. Press *[OK]*. Press one of the arrow buttons repeatedly until the display shows 'SL'. Press *[OK]*. Now you can set the number for the device via which it is addressed by the master as a slave. Use the arrow buttons to select a value between 1 and 512 (display shows 'A001' ... 'A512').

This setting is only relevant if the device is operating as Slave controlled by a Master, but not via DMX. When the display shows the desired value press *[OK]* to confirm the selection and then *[M]* to return to the parent menu. To return to the parent menu without making changes, press *[M]*.

Manual test

Press *[M]*. Press one of the arrow buttons repeatedly until the display shows 'TEST'. Press *[OK]*. Press one of the arrow buttons repeatedly until the display shows 'RED', 'GREE', 'BLUE', 'WHIT' or 'STRO'. Press *[OK]*. Now you can set the brightness of the red, green, blue or white LEDs each in a range from 0 to 255, or select the strobe rate in a range of 0 to 24.

This mode is also suitable for generating constant or flashing light of a colour mixed from the four LED colours without DMX control.

When the display shows the desired value press *[OK]* to confirm the selection and then *[M]* to return to the parent menu. To return to the parent menu without making changes, press *[M]*.

Fade programmes

Press *[M]*. Press one of the arrow buttons repeatedly until the display shows 'FADE'. Press *[OK]*. Now you can set the fade programmes of the preprogrammed automatic shows. Use the arrow buttons to select a value between 1 and 7 (display shows 'F-01' ... 'F-07').

This setting is only relevant if the device is not controlled via DMX. When the display shows the desired value, press *[OK]* to confirm the selection and return to the main menu. To return to the main menu without making changes, press *[M]*.

Colour selection

Press *[M]*. Press one of the arrow buttons repeatedly until the display shows 'COLO'. Press *[OK]*. Now you can set a basic colour for the preprogrammed automatic shows. Use the arrow buttons to select a value between 1 and 4 (display shows 'C-01' ... 'C-04').

This setting is only relevant if the device is not controlled via DMX. When the display shows the desired value, press *[OK]* to confirm the selection and return to the main menu. To return to the main menu without making changes, press *[M]*.

7.3 Menu overview

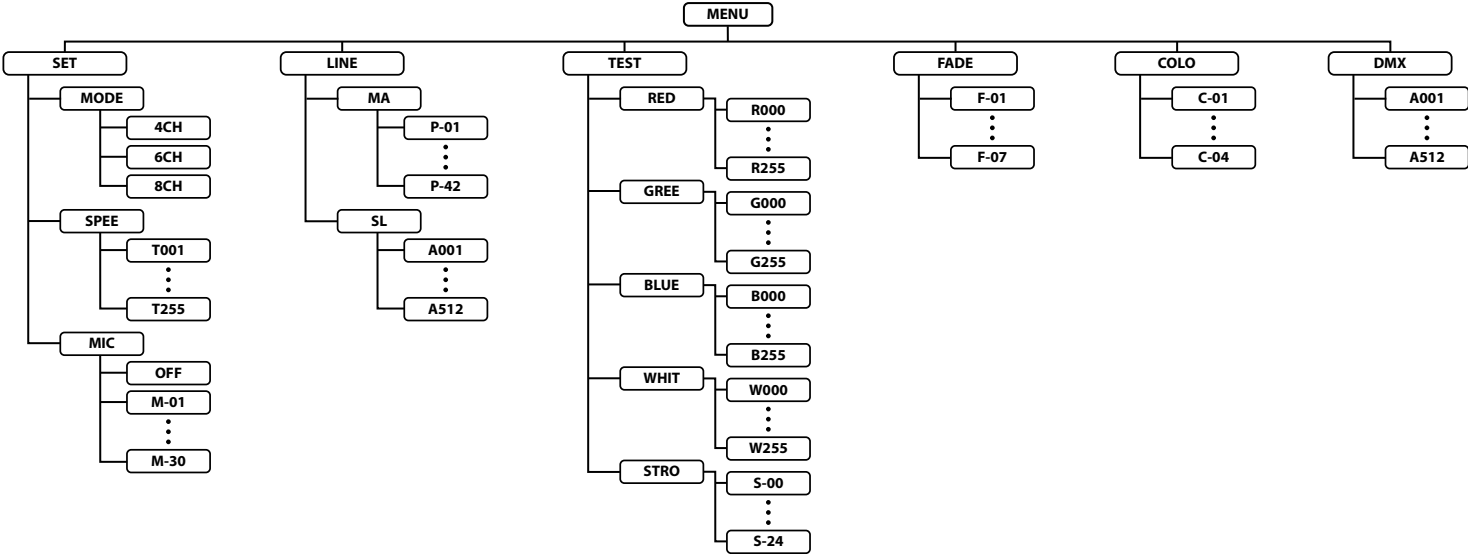

CX-30 RGBW, CX-30 RGBW BRS, CX-30 RGBW WH, CX-30 RGB WW Bk, CX-30 RGB WW BRS

7.4 Functions in 4-channel DMX mode

Channel	Value	Function
1	0...255	Intensity red (0 % to 100 %)
2	0...255	Intensity green (0 % to 100 %)
3	0...255	Intensity blue (0 % to 100 %)
4	0...255	Intensity white (0 % to 100 %)

7.5 Functions in 6-channel DMX mode

Channel	Value	Function
1	Operating mode selection	
	0...63	Constant colour, the hue is set by channels 2 to 5
	64...127	Automatic colour change with 7 colours, channels 2-5 without function
	128...191	Automatic colour change with 12 colours, channels 2-5 without function
	192...255	Automatic colour change with 4 colours, channels 2-5 without function
2	0...255	Intensity red (0 % to 100 %), if channel 1 = 0...63
3	0...255	Intensity green (0 % to 100 %), if channel 1 = 0...63
4	0...255	Intensity blue (0 % to 100 %), if channel 1 = 0...63
5	0...255	Intensity white (0 % to 100 %), if channel 1 = 0...63
6	Effects speed and sound control sensitivity	
	0...10	No automatic colour change

CX-30 RGBW, CX-30 RGBW BRS, CX-30 RGBW WH, CX-30 RGB WW Bk,
CX-30 RGB WW BRS

Channel	Value	Function
	11...255	Automatic colour change as set by channel 1, decreasing speed from fast to slow if channel 1 = 64...127
		Automatic colour change as set by channel 1, increasing speed from slow to fast if channel 1 = 128...191
		Sound control sensitivity (from low to high sensitivity) if channel 1 = 192...255

7.6 Functions in 8-channel DMX mode

Channel	Value	Function
1	0...255	Intensity Red (0 % to 100 %), if channel 5 = 0...15 and channel 7 = 0...31
2	0...255	Intensity Green (0 % to 100 %), if channel 5 = 0...15 and channel 7 = 0...31
3	0...255	Intensity Blue (0 % to 100 %), if channel 5 = 0...15 and channel 7 = 0...31
4	0...255	Intensity White (0 % to 100 %), if channel 5 = 0...15 and channel 7 = 0...31
5	Fixed colour pattern	
	0...15	No fixed colour and movement pattern
	16...255	One of 31 preprogrammed colours, channels 6 and 7 without function
6	Strobe effect	
	0...15	Full brightness, no strobe effect
	16...255	Strobe effect, increasing speed, if channel 5 = 0...15
7	Operating mode selection	

CX-30 RGBW, CX-30 RGBW BRS, CX-30 RGBW WH, CX-30 RGB WW Bk,
CX-30 RGB WW BRS

Channel	Value	Function
	0...31	Constant colour, the hue is set by channels 1 to 4
	32...63	Fade-out effect, speed controlled by channel 6
	64...95	Fade-in effect, speed controlled by channel 6
	96...127	Fade-in-out effect, speed controlled by channel 6
	128...159	Auto-mix effect, speed controlled by channel 6, channels 1 to 5 without function
	160...191	Chase (4 colours), speed controlled by channel 6, channels 1 to 5 without function
	192...223	Chase (12 colours), speed controlled by channel 6, channels 1 to 5 without function
	224...255	Sound-controlled colour change, microphone sensitivity increasing
8	0...255	Dimmer (0 % to 100 %)

8 Technical specifications

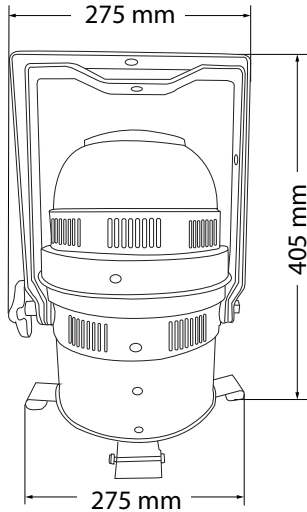

Light source		Item no. 467321, 469061, 523385: 18 × 4in1 RGBW LED, 8 W each
		Item no. 467325, 523387: 18 × 4in1 RGB WW LED, 8 W each
Optical properties	Beam angle	25 °
Control		DMX Buttons and display
Number of DMX channels		4, 6 or 8
Input connections	Power supply	Lockable input socket (Power Twist)
	DMX control	XLR chassis socket, 3-pin
Output connections	Power supply	Lockable output socket (Power Twist)

CX-30 RGBW, CX-30 RGBW BRS, CX-30 RGBW WH, CX-30 RGB WW Bk,
CX-30 RGB WW BRS

	DMX control	XLR chassis socket, 3-pin
Power consumption		120 W
Supply voltage		100 - 240 V ~ 50/60 Hz
Degree of protection		IP20
Mounting options		Hanging, standing
Dimensions (W × H × D)		275 mm × 405 mm × 275 mm
Weight		3.4 kg
Ambient conditions	Temperature range	0 °C...40 °C
	Relative humidity	20 %...80 % (non-condensing)

Further information

	CX-30 RGBW	CX-30 RGBW BRS	CX-30 RGBW WH
	Item no. 467321	Item no. 469061	Item no. 523384
	Item no. 469059 (Tourpack 4)	Item no. 469060 (Tourpack 4)	
Construction	PAR 64	PAR 64	PAR 64
Colour mixture	RGBW	RGBW	RGBW
LED type	x-in-1	x-in-1	x-in-1
Base housing	yes	yes	yes
Fanless	No	No	No
Remote control	Not possible	Not possible	Not possible
Wireless DMX	No	No	No
Housing colour	Black	Brushed silver	White

CX-30 RGBW, CX-30 RGBW BRS, CX-30 RGBW WH, CX-30 RGB WW Bk,
CX-30 RGB WW BRS

	CX-30 RGB WW Bk	CX-30 RGB WW BRS
	Item no. 467325	Item no. 523387
	Item no. 523393 (Tourpack 4)	Item no. 523394 (Tourpack 4)
Construction	PAR 64	PAR 64
Colour mixture	RGB WW	RGB WW
LED type	x-in-1	x-in-1
Base housing	yes	yes
Fanless	No	No
Remote control	Not possible	Not possible
Wireless DMX	No	No
Housing colour	Black	Brushed silver

9 Plug and connection assignments

Introduction

This chapter will help you select the right cables and plugs to connect your valuable equipment so that a perfect light experience is guaranteed.

Please take our tips, because especially in 'Sound & Light' caution is indicated: Even if a plug fits into a socket, the result of an incorrect connection may be a destroyed DMX controller, a short circuit or 'just' a not working light show!

DMX connections

The unit offers a 3-pin XLR socket for DMX output and a 3-pin XLR plug for DMX input. Please refer to the drawing and table below for the pin assignment of a suitable XLR plug.



Pin	Configuration
1	Ground, shielding
2	Signal inverted (DMX-, 'cold signal')
3	Signal (DMX+, 'hot signal')

CX-30 RGBW, CX-30 RGBW BRS, CX-30 RGBW WH, CX-30 RGB WW Bk, CX-30 RGB WW BRS

10 Troubleshooting



NOTICE!

Possible data transmission errors

For error-free operation make use of dedicated DMX cables and do not use ordinary microphone cables.

Never connect the DMX input or output to audio devices such as mixers or amplifiers.

In the following we list a few common problems that may occur during operation. We give you some suggestions for easy troubleshooting:

Symptom	Remedy
The unit does not work, no light.	Check the mains connection and the fuse.
No response to the DMX controller.	1. Check the DMX ports and cables for proper connection.
	2. Check the address settings and the DMX polarity.
	3. Try using another DMX controller.
	4. Check to see if the DMX cables run near or alongside to high voltage cables that may cause damage or interference to DMX interface circuits.

If the procedures recommended above do not succeed, please contact our Service Center. You can find the contact information at www.thomann.de.

11 Cleaning

Optical lenses

Clean the optical lenses, that are accessible from the outside, regularly in order to optimize the light output. The frequency of cleaning depends on the operating environment: wet, smoky or particularly dirty surroundings can cause more accumulation of dirt on the optics of the device.

- Clean with a soft cloth using our lamp and lens cleaner (item no. 280122).
- Always dry the parts carefully.

Fan grids

The fan grids of the device must be cleaned of any contamination, such as dust, etc. on a regular basis. Before cleaning, switch off the device and disconnect mains-operated devices from the mains. Only use pH-neutral, solvent-free and non-abrasive cleaning agents. Clean the unit with a slightly damp lint-free cloth.

12 Protecting the environment

Disposal of the packaging material



For the transport and protective packaging, environmentally friendly materials have been chosen that can be supplied to normal recycling.

Ensure that plastic bags, packaging, etc. are properly disposed of.

Do not just dispose of these materials with your normal household waste, but make sure that they are collected for recycling. Please follow the notes and markings on the packaging.

Disposal of your old device



This product is subject to the European Waste Electrical and Electronic Equipment Directive (WEEE) in its currently valid version. Do not dispose with your normal household waste.

Dispose of this device through an approved waste disposal firm or through your local waste facility. When discarding the device, comply with the rules and regulations that apply in your country. If in doubt, consult your local waste disposal facility.

CX-30 RGBW, CX-30 RGBW BRS, CX-30 RGBW WH, CX-30 RGB WW Bk,
CX-30 RGB WW BRS

th.mann
MUSIC IS OUR PASSION



Musikhaus Thomann · Hans-Thomann-Straße 1 · 96138 Burgebrach · Germany · www.thomann.de