

Source Four[®]



Assembly Guide

Production Dates: September 2004 - Present

ATTENTION: The part numbers listed in this guide may differ from the parts required for your particular Source Four fixture. Part numbers for fixtures change occasionally as parts are replaced or upgraded.

To ensure that you are ordering the proper part for your specific fixture, please contact your ETC dealer, or ETC Customer Service for assistance.

Table of Contents

Basic Assembly	1
Lamp Socket Assembly	2
Assemble lamp socket.	3
Reflector Housing Assembly	6
Remove reflector	7
Install reflector	8
Clean reflector	8
Front Barrel Assembly	9
Assemble front barrel.	10
19°, 26°, 36°, and 50° Lens Tubes	12
Assemble lens tube (19°, 26°, 36°, and 50°)	13
Cleaning 19°, 26°, 36°, and 50° glass lenses	14
10° Lens Tube	15
5° Lens Tube	16
Assemble 5° and 10° lens tubes	17
Clean 5° and 10° polymer lenses	17

ETC[®], Emphasis[®], Expression[®], Insight[™], Imagine[™], Focus[™], Express[™], Unison[®], Obsession[®] II, ETCNet2[™], EDMX[™], Source Four[®], Revolution[®], Sensor[®], and WYSILink[™] are either registered trademarks or trademarks of Electronic Theatre Controls, Inc. in the United States and other countries.

All other trademarks, both marked and not marked, are the property of their respective owners.

Basic Assembly

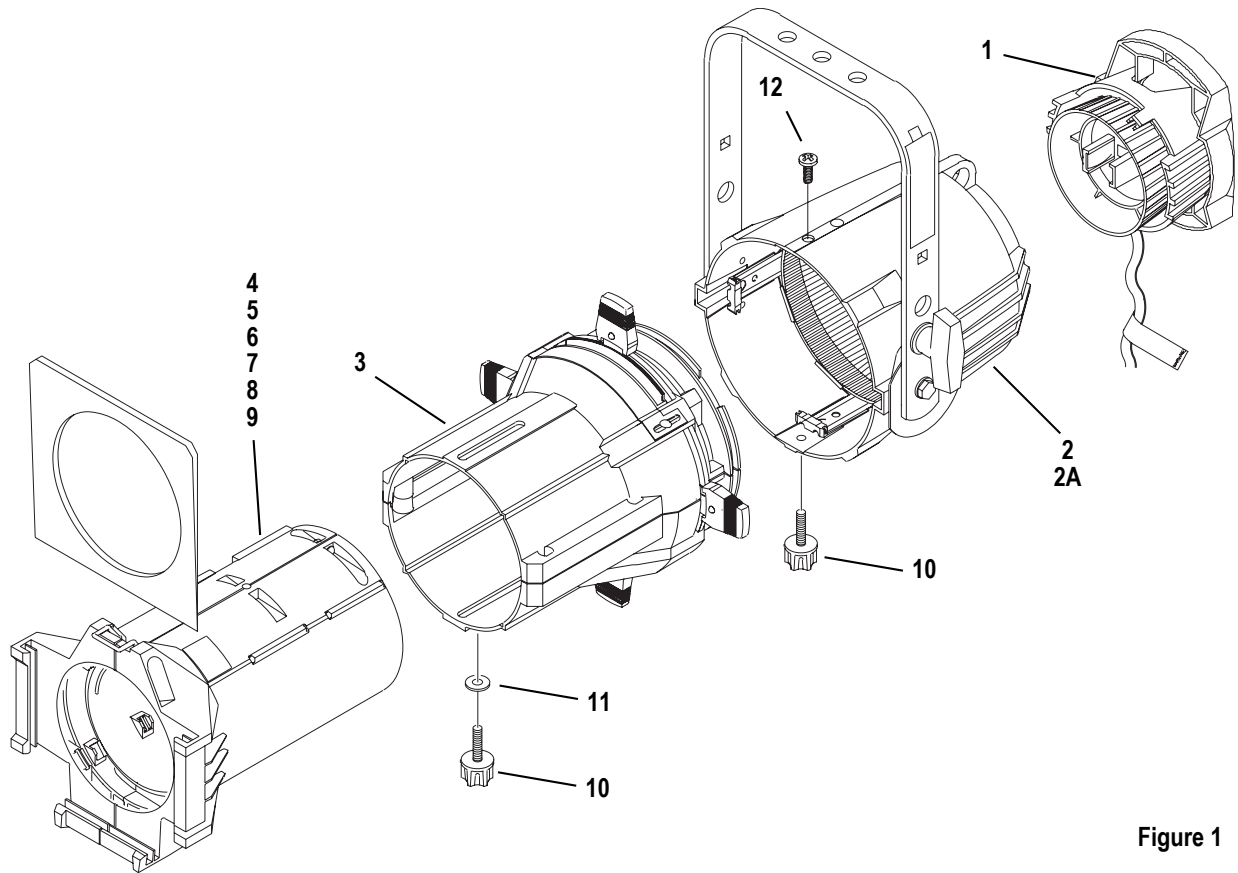

Figure 1

Reference Number	Part Number	Description	Quantity Required
1	7060A2008	Lamp socket assembly	1
2	7060A2011	Rear housing assembly, single clutch	1
2A	7060A2020	Rear housing assembly, double clutch	1
3	7060A2012	Front barrel assembly	1
4	7060A2000-K	5° lens tube, with knob (See page 16)	1
5	7060A2001-K	10° lens tube, with knob (See page 15)	1
6	7060A2002-K	19° lens tube (6 x 16), with knob	1
7	7060A2003-K	26° lens tube (6 x 12), with knob	1
8	7060A2004-K	36° lens tube (6 x 9), with knob	1
9	7060A2005-K	50° lens tube (4.5 x 6), with knob	1
10	7060A4008-01	Knob set with male insert	2
11	HW5143	Washer, flat fiber	1
Optional Equipment			
12	HW5197	Screw, 1/4-20 x 5/8, black zinc	1

Lamp Socket Assembly

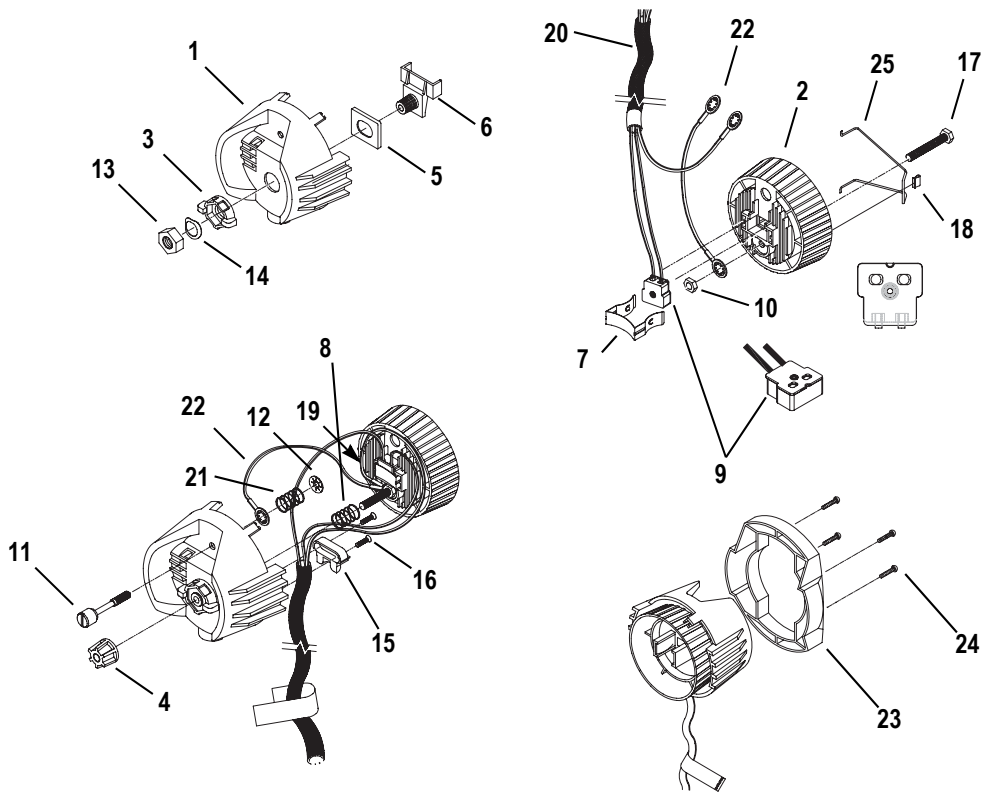

Figure 2

Reference Number	Part Number	Description	Quantity Required
1	7060A3055	Housing, socket, casting, painted	1
2	7060A3057	Socket, light baffle casting, painted	1
3	7060A4007	Knob, X-Y, lamp set	1
4	7060A4008-02	Knob, Z, lamp set w/female insert	1
5	7060A4011	Bushing, cup	1
6	7060A3011	Hub, index, casting	1
7	7060A3012	Spring, lamp retainer	1
8	HW748	Spring, compression	1
9	7060B7019	Complete UL socket assembly	1
10	HW534	Nut, hex, 1/4-20, black zinc	1
11	7060A3025	Screw, 1/4-20 knurled head	1
12	HW746	Retaining ring, flat, Southco	1
13	HW5123	Nut, hex, 9/16-18, black zinc	1
14	HW747	Washer, wave	1
15	7060A3056	Clamp, strain relief, painted	1
16	HW3103	Screw, 8-32 x 5/8 PhFHMS, black zinc	2
17	HW5122	Bolt, 1/4-20 x 1.75, full thread, black zinc	1
18	HW8209	Clip Tinnerman	1
19	7060B7003	48" W420 wire, 16 gauge, 200° C/300V, green UL 1180/CSA AWM with lug J490T installed	1
20	W6195	36" sleeve, fiberglass	1
21	HW749	Spring, ground	1
22	7060B7007	4" W420 wire, 16 gauge, 200° C/300V, green, UL 1180/CSA AWM with two J490T lugs installed	1
23	7060A4037	Handle, insulated rear, black	1
24	HW2181	Screw, 6-32 x 3/4, Tapitite	4
25	7060A3085	Source Four Lamp Retainer Wire	1

Assemble lamp socket

Tools Required:

- Open-end adjustable wrench or a 7/16" socket
- Needle-nose pliers
- #2 Phillips screwdriver

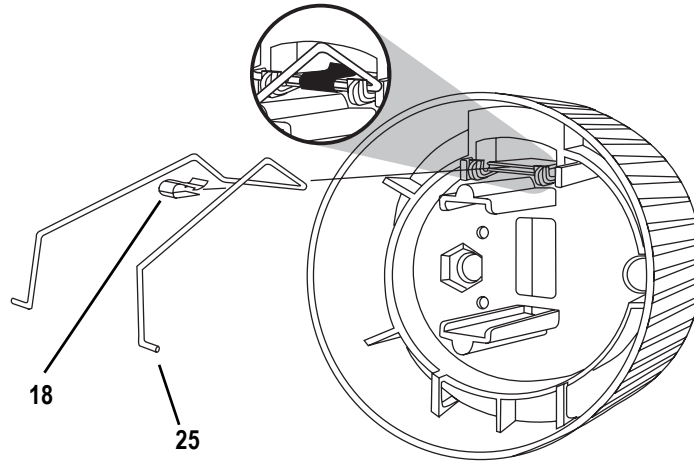

Figure 3

- Step 1: Set the crossbar of the retainer clip (25) under the two hooks on the clip bracket as shown in [Figure 3](#).
- Step 2: Place the Tinnerman clip (18) over the retainer clip crossbar between the two hooks and press it down firmly until it snaps into place.

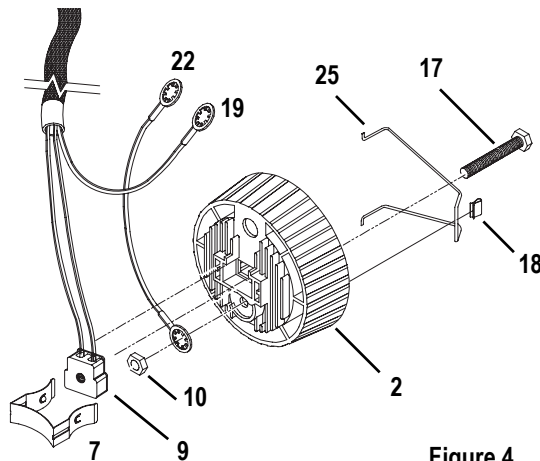

Figure 4

- Step 3: Insert the bolt (17) through the light baffle socket casting (2). See [Figure 4](#).
- Step 4: Install the green ground wire assemblies (19 and 22) on the bolt (17) with the prongs on the crimped connectors toward the casting. Run both wires through the indent in the lip around the bolt hole. Secure with nut (10) and torque to 60 inch pounds.
- Step 5: Place the socket assembly (9) into the light baffle socket casting (2). Be sure it is well seated.

- Step 6: Install the lamp retainer spring (7). The lamp retainer spring secures the socket. Insert the spring one end at a time, making sure the rectangular slot in each side of the spring seats on the corresponding tab in the casting.



Note: *If the spring does not seat correctly, coax it into place with a screwdriver or needle-nose pliers.*

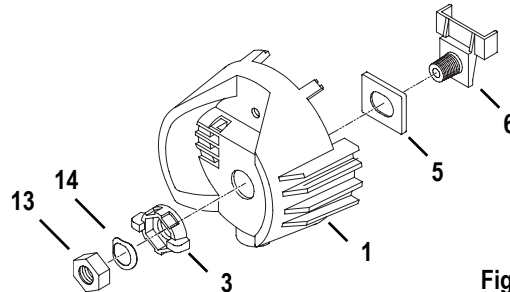

Figure 5

- Step 7: Install the bushing cup (5) into the housing socket casting (1) as shown in [Figure 5](#). The cup should slide smoothly up and down, but not side to side.
- Step 8: Insert the threaded end of the index hub (6) through the holes in the bushing cup and the back of the housing socket casting (1).
- Step 9: Slide the X-Y knob (3) over the exposed index hub bolt (6), then insert the wave washer (14) on the bolt and secure with the 9/16 hex nut (13). Hand tighten the X-Y knob (3).



Note: *Install the wave washer with the upward curve toward the hex nut.*

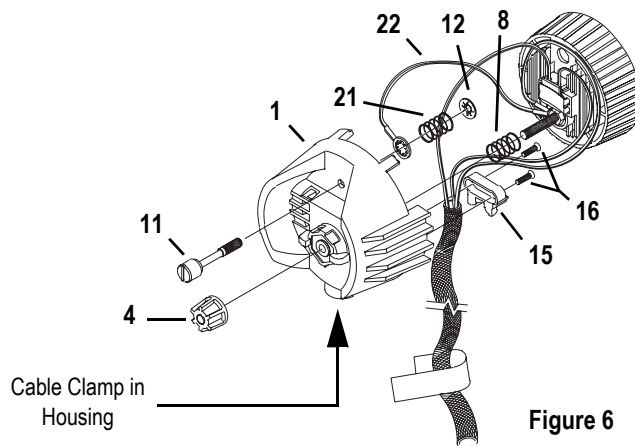

Figure 6

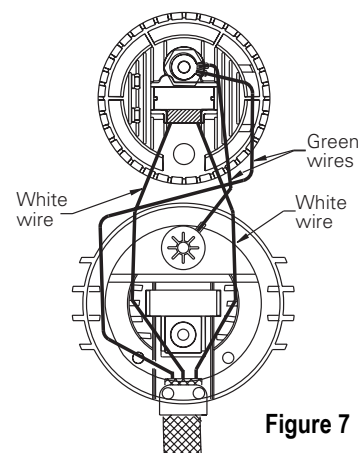

Figure 7

- Step 10: Insert the knurled head screw (11) through the housing socket casting (1) as shown in [Figure 6](#).
- Step 11: Install the shorter green ground wire (22) onto the screw. The prongs on the crimped connector should be toward the casting.
- Step 12: Install the ground spring (21) onto the screw and secure it with the Southco flat retaining ring (12). Install the Southco ring with its prongs away from the casting.



Note: Use pliers to straighten the Southco retaining ring (12) if it bends when you install it on the bolt.

Step 13: Lay the leads in the bottom half of the cable clamp (located in the housing socket casting [1]), making sure that the fiberglass sleeving extends slightly past the screw holes in the housing socket casting. Install new sleeving if necessary. Then, route the wires as shown in [Figure 7](#).



CAUTION: You must follow the wire routing diagram to ensure that the socket leads do not interfere with the lamp focus mechanism.

Step 14: Install the top half of the cable clamp (15) and secure it with the two screws (16). Tighten the screws alternately to ensure a solid connection.



Note: To ensure that the clamp holds the cable tightly, flatten the cable, then fold over the sleeving before you install the top half of the clamp. Make sure the top edge of the cable clamp is even with the edge of the socket to prevent interference with lamp focus movement. Make sure sleeving is not pinched.

Step 15: Using the four screws (24), attach the handle (23) to the lamp socket assembly. See [Figure 2](#).

Step 16: Place the compression spring (8) on the protrusion on the inside of the index hub (6).

Step 17: Insert bolt (17) through spring (8) and through the index hub (6) of the housing socket (1), joining the two castings. Make sure wires are not pinched between the two pieces.

Step 18: Before proceeding, check again to make sure the wires are still positioned as indicated in [Figure 6](#). Adjust if necessary.

Step 19: Press the two castings together firmly so the bottom of the light baffle (2) sits on top of the cable clamp (15), then install the X-Y lampset (3) and Z lamp knob (4). Hand tighten the knob all the way to the right.



CAUTION: You must install Z knob as described above to ensure proper lamp focus travel.

Reflector Housing Assembly

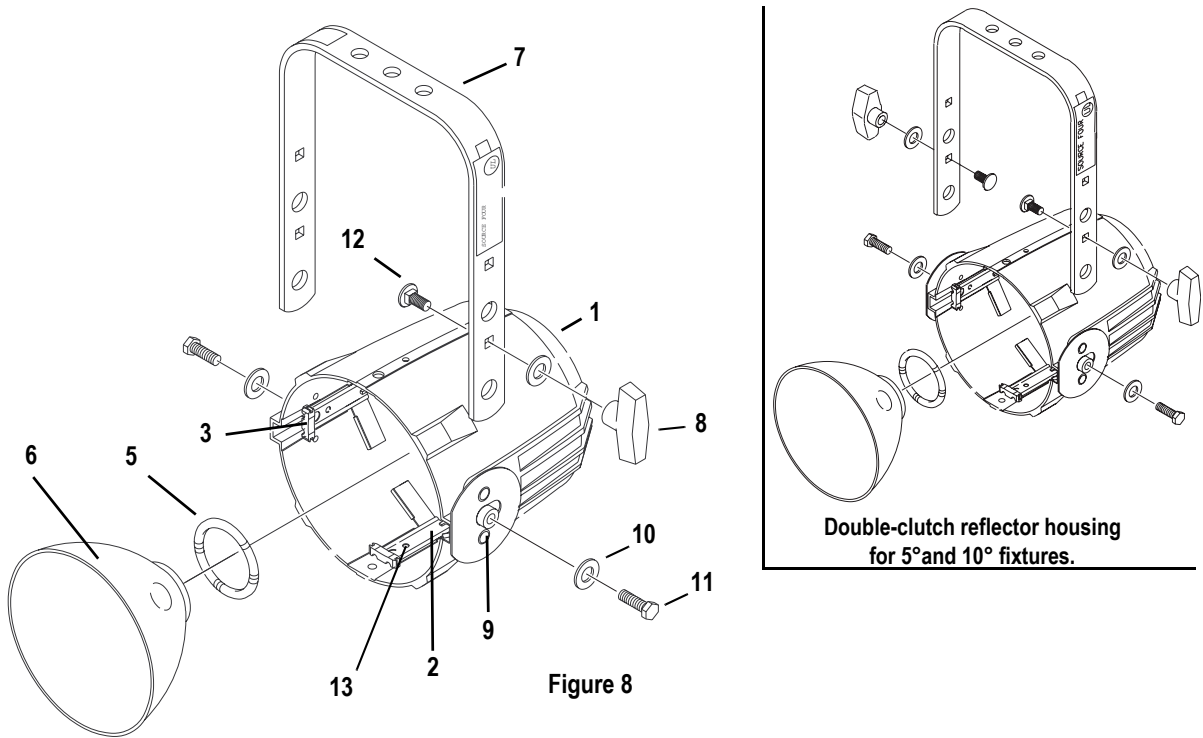

Reference Number	Part Number	Description	Quantity Required
1	7060A3054	Housing, reflector casting, painted black	1
2	7060A3006	Clip, reflector retainer	4
3	7060A4010	Bushing, gate	4
4	7060A3016	Plate, clutch	1
5	7060A3019	Spring, reflector support	1
6	7060A4015	Reflector, molded glass, coated	1
7	7060A3058	Bracket, yoke, painted	1
8	HW8144	Handle, yoke knob, 5/16 - 18	2
9	HW753	Rivet, machine, 3/16 x .720, flat head, black zinc	2
10	HW5126	Washer, flat, 5/16, black zinc	4
11	HW5193	Bolt 5/16-18 x 3/4, black zinc	2
12	HW5125	Bolt, carriage, 5/16-18 x .75, black zinc	2
13	HW752	Rivet machine, 3/16 x 5/16, black zinc	4

Remove reflector

Tools Required:

- minimally padded work surface (cardboard, carpet, or rubber mat recommended)



WARNING: *This procedure may crack or break the reflector. Always wear gloves, safety glasses, and a dust mask when performing this procedure.*

- Step 1: Place the reflector housing face down on your work surface so that the concave reflector surface points downward.
- Step 2: Loosen the clutch and rotate the yoke so that it is perpendicular to the housing at roughly a 90° angle. Tighten the clutch.
- Step 3: Using the yoke as your handle, raise the housing assembly off of the work surface a few inches and then firmly tap the housing on the work surface. This should force the reflector out of its clips.
- Step 4: Carefully lift the housing to see if the reflector is released. If it is not, repeat step 3 with slightly more force.

Install reflector



Note: *The following assumes all four reflector retainer clips (2) have already been riveted to the reflector housing casting (1) and the gate bushings (3) installed on the retainer clips.*

- Step 1: Place the reflector housing casting (1) on a flat work surface with the large opening facing up.
- Step 2: Install the reflector support spring (5) in the circular opening at the base of the casting.
- Step 3: Insert the reflector (6) at an angle, under any three adjacent legs of the reflector's clips.
- Step 4: Gently press down on the opposite side of the reflector until it snaps into place under the remaining clips.

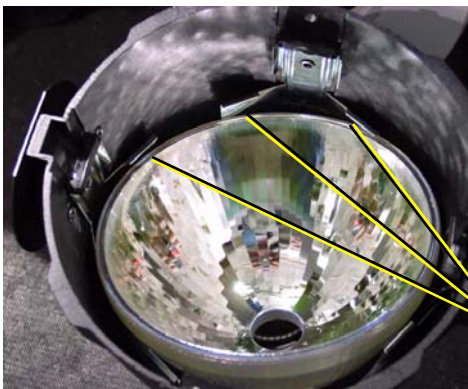

Step 3

Under three adjacent clips.



Step 4



Note: *If the reflector does not snap in, turn the casting over. Gently pull on the side of the reflector that has not snapped in until the rest of the reflector slides into place.*

Clean reflector

Remove dust with a blast of oil-free air or wipe with a clean, lint-free cloth using alcohol or distilled water (alcohol is recommended).



WARNING: *Do not use glass and window cleaners on the reflector. Chemicals in these cleaners will stain the reflector.*

Front Barrel Assembly

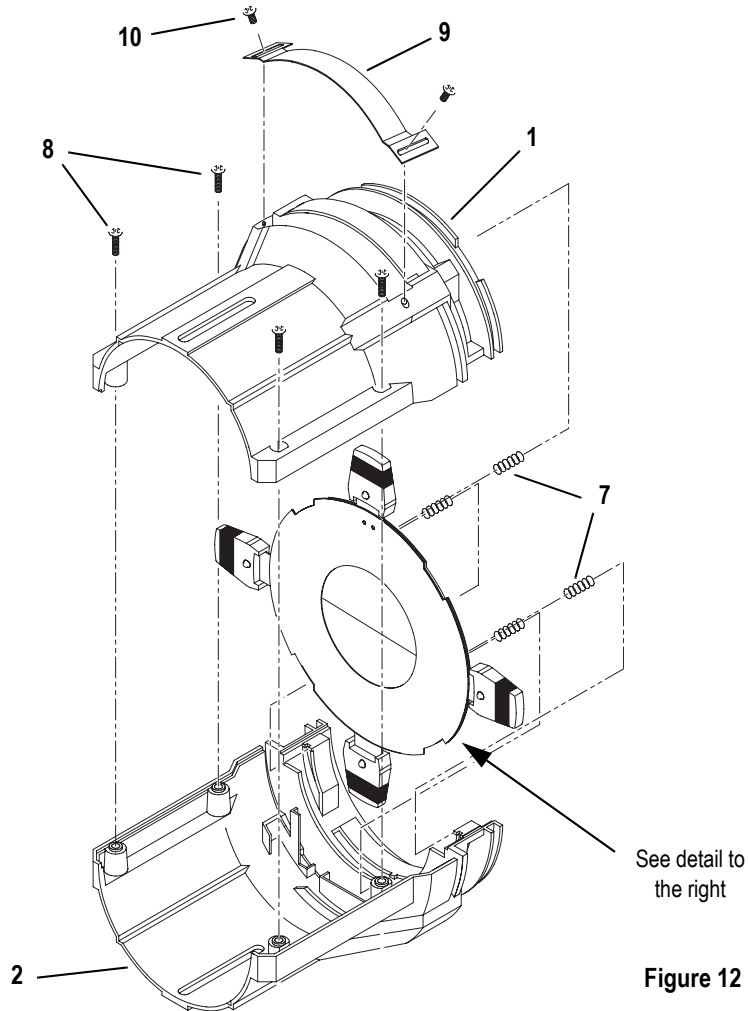

Figure 12

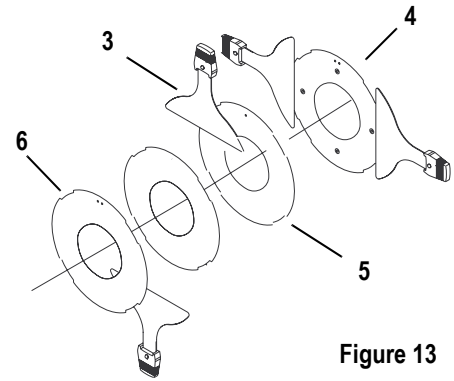

Figure 13

Shutter Assembly: The bottom divider plate (4) has four dimples punched into the surface; the top plate (6) has none. The middle divider plates (5) are noticeably thinner-gauge metal than the other two.

Reference Number	Part Number	Description	Quantity Required
1	7060A3052	Front barrel, top casting, painted	1
2	7060A3053	Front barrel, bottom casting, painted	1
3	7060A2025	Shutter blade assembly, 22 gauge	4
4	7060A3001-01	Plate, divider with dimples (bottom)	2
5	7060A3003	Plate, gate (middle)	1
6	7060A3001-02	Plate, divider (top)	1
7	HW754	Shutter spring	4
8	HW3165	Screw, 8/32 x 1/2, Taptite	4
9	7060A3045	Cover, iris slot	1
10	HW372	Screw, 8-32 x 1/4, black zinc	2

Assemble front barrel

Tools Required:

- #2 Phillips head screwdriver

Step 1: Stand the top and bottom front barrel castings (1 and 2) upright with the shutter end of the castings toward the bottom.



Note: *The top front barrel casting contains the iris slot.*

Step 2: Slide the bottom divider plate (4), into its place in the bottom casting (2). The dimples on the divider plate must point down.



Note: *The bottom divider plate (4) has four dimples punched into the surface; the top plate (6) has none. The middle divider plates (5) are noticeably thinner-gauge metal than the other two.*

The notches on the divider plates must fit against the flanges in the casting so the plates do not move.



WARNING: *Divider plate edges are sharp. Handle with caution.*

Step 3: With the bottom barrel casting (2) to your left, place two shutter blades (3) on top of dimple plate (4) and opposite each other so together they form a barrier. The handles should extend past the barrel casting, rivets pointed down. These will be the side shutters (See [Figure 13](#)).

Step 4: Place a divider plate (5) on top of the two shutter blades.

Step 5: Place another shutter blade on top of the middle divider plates and perpendicular to the previously installed shutter blades. This will be the top shutter, so align the handle away from the bottom casting (2). Then place the other divider plate on top.

Step 6: Place the fourth shutter blade on top of the divider and through the bottom casting in the final shutter position. Pull the blade and plate assembly slightly forward to allow the handle to slip through the slot in the bottom casting. Then fully seat the blader assembly into the casting again.

Step 7: Place the top divider plate (6) on top of the fourth shutter blade.



Note: *Make sure no shutter assembly components are under the pattern holder guides.*

Step 8: With both front barrel castings still standing upright, join the two halves, sliding the handle of the top shutter blade through the slot in the top front barrel casting (1).

Step 9: Starting at the bottom of the castings (closest to the shutters), use four PHMS screws (9) to fasten the front barrel casting halves together, as shown. Torque the screws to 25 inch/pounds.



Note:

The ends of the two front barrel castings must be even. Adjust as necessary before completely tightening the nuts and screws. Failure to do this could interfere with the barrel rotation.

Step 10: Turn the front barrel assembly over so that the narrower end is on your work surface.

Step 11: Install the four shutter springs (7) between the four dimples in the shutter plate and the tabs in the lip of the casting.



Note:

Install the springs at the joints in the castings on either of the tabs at the joint. Once they are installed, the springs at the joints will sit at a slight angle.



WARNING:

During assembly, the shutter springs can pop out of place. Always wear protective eyewear during this procedure.

Step 12: Place iris slot cover (9) over the iris slot. Use two screws (10) to secure the cover.

19°, 26°, 36°, and 50° Lens Tubes

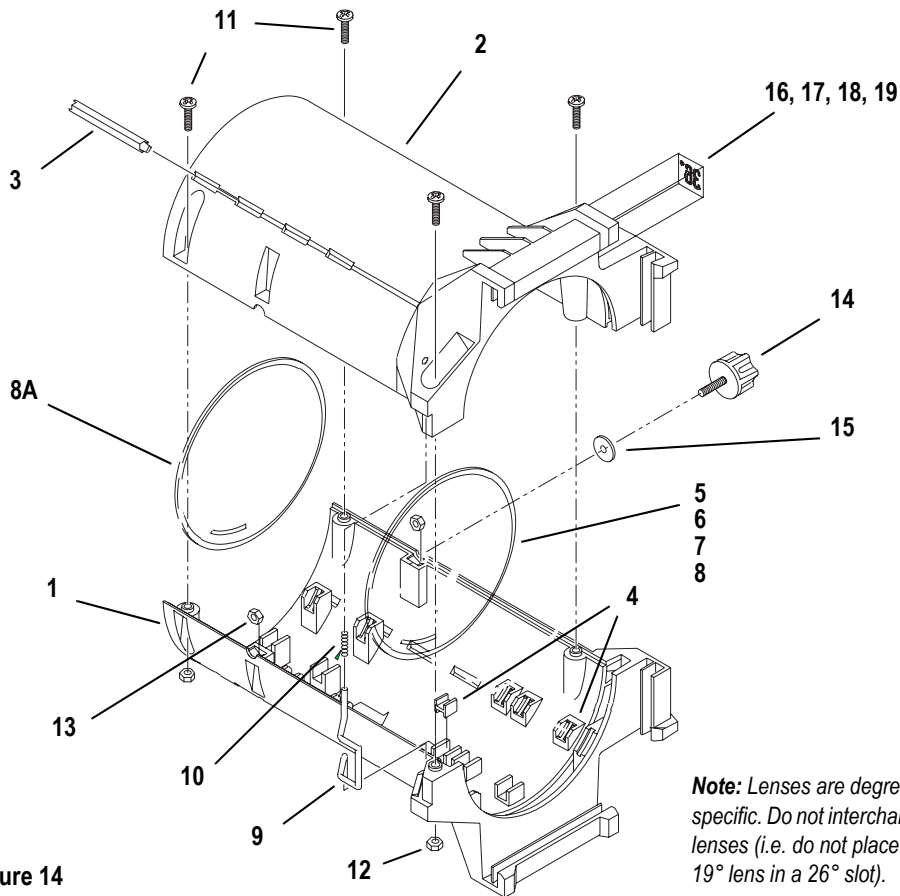
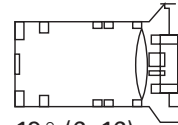

Figure 14

Note: Lenses are degree specific. Do not interchange lenses (i.e. do not place a 19° lens in a 26° slot).

Place side of lens with paint dot toward front of lens tube.



19° (6x16)
Red dot

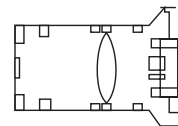

26° (6x12)
Black dot

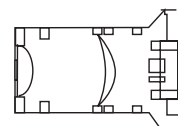

36° (6x9)
No dot

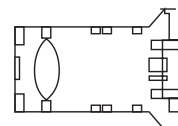

50° (4.5x6)
Yellow dot

Reference Number	Part Number	Description	Quantity Required
1	7060A3137	Lens tube, left, painted	1
2	7060A3139	Lens tube, right, painted	1
3	7060A4009	Bushing, guide	8
4	7060A4012	Pad lens support - asphere	5
		Pad lens support - meniscus set	10
5	7060A4002	Aspheric lens, 19°	1
6	7060A4001	Aspheric lens, 26°	1
7	7060A4004	Aspheric lens, 50°	1
8	7060A4020	Meniscus lens, 36° set, front	1
8A	7060A4021	Bi-convex lens, 36° set, rear (36° Only)	1
9	7060A3079	Clip, gel retainer, 90° bend	1
10	HW750	Spring, retainer	1
11	HW369	Screw, PHMS, 8-32 x 3/4, black zinc	4
12	HW370	Nut, Ny-Lok, 8/32, black zinc	3
13	HW534	Nut, hex, 1/4-20, black zinc	2
14	7060A4008-01	Knob set with male insert	1
15	HW5143	Washer, flat, 1/4	1
16	7060A4033	19° lens tube label	1
17	7060A4034	26° lens tube label	1
18	7060A4035	36° lens tube label	1
19	7060A4036	50° lens tube label	1

Assemble lens tube (19°, 26°, 36°, and 50°)

Tools Required:

- #2 Phillips head screwdriver

Step 1: Place the left and right lens holder castings (1 & 2) face up on your work surface. Align the castings so the colorframe grooves are to your left

Step 2: Install lens support pads (4) as required inside both lens holder castings. Four pads are required per lens. Insert pads short-side down, as shown.

Step 3: Install the 1/4-20 hex nut (13) in the left lens holder casting as shown.

Figure 15

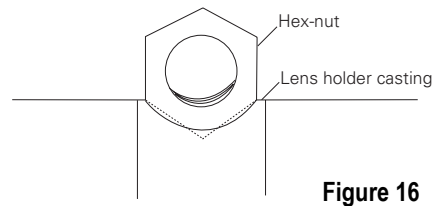
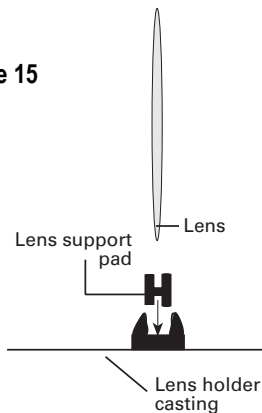

Step 4: Install the short end of the gel retainer clip (9) in the left lens holder casting (1).

Step 5: Position the clip in the forward, locked position, then install the retainer spring (10) on the clip.

Step 6: Install the required lens (or lenses) (5, 6, 7, or 8 & 8A) as shown on [page 12](#).



Note:

19°, 26° and 50° aspheric lenses have painted dots to orient the lens in the tube. Install the lens with the painted dot facing the front of the tube. Seat the lens in the support pads so the dot remains visible.

Step 7: Invert the right lens casting (2) and hold it above the left lens casting (1). Fit the clip (9) and spring (10) into the right lens casting. Gently place the right lens casting onto the left lens casting, making sure that the 1/4-20 hex nut and retaining clip assembly stay properly seated. Make sure the lens stays straight by looking into the lens holder. The top edge of the lens should seat properly in the support pads.

Step 8: Install the PHMS screws (11) in four locations with Ny-lok nuts (12). The PHMS screw location on the bottom of the colorframe holder is threaded and does not require a Ny-lok nut. Hold the nuts tight against the casting and torque the screws to 25 inch pounds.

Step 9: Install the eight bushing guides (3). Point the narrow tab on the bottom toward the back of the casting; point the square tab toward the front. Squeeze the guides slightly so they bend in the middle then snap into place. Make sure the rounded side of the guide faces outward from the tube.

Cleaning 19°, 26°, 36°, and 50° glass lenses

Step 1: Dampen a clean, lint-free cloth with vinegar or household ammonia. You may use water, but it leave spots. You can remove the spots by polishing the lens gently with a clean, dry cloth.



WARNING: *Never use glass and window cleaner or any abrasive material to clean the lens. Glass and window cleaners will stain the lens surface. Abrasive materials (such as steel wool) will damage the surface of the lens.*

Step 2: Starting from the center, gently wipe the lens.

10° Lens Tube

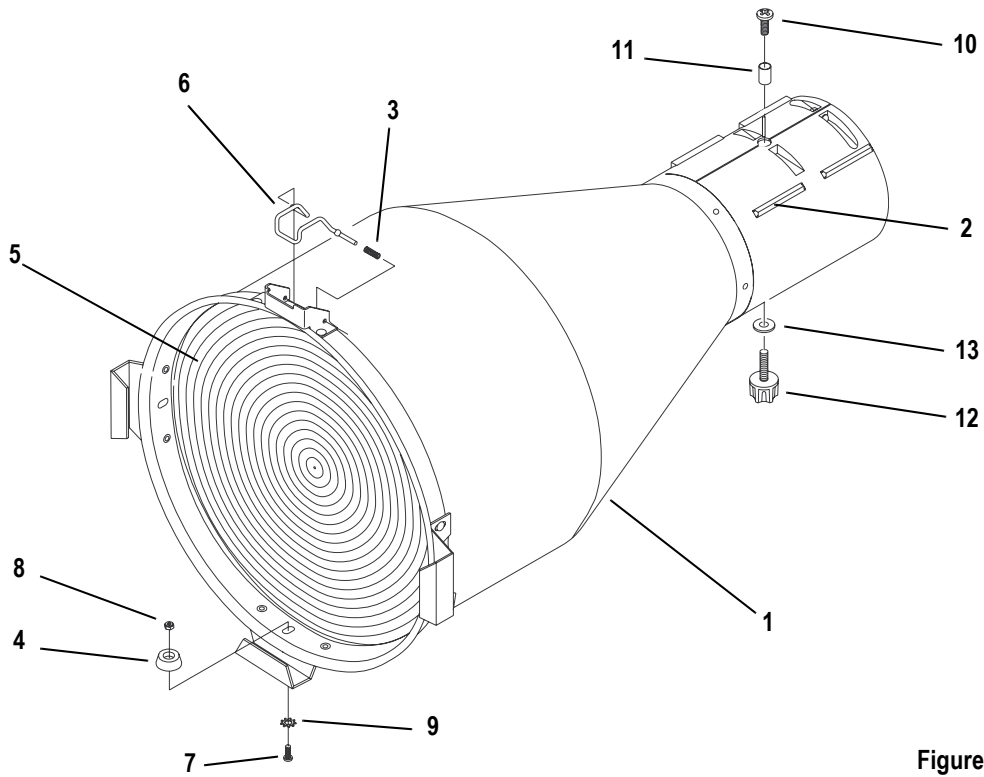

Figure 17

Reference Number	Part Number	Description	Quantity Required
1	7060A3096	10° lens tube assembly, painted	1
2	7060A4009	Bushing, guide	8
3	HW750	Spring, retainer	1
4	HW6122	Bumper, recess rubber	4
5	7060A4025	Lens, 10°, 10"	1
6	7060A3079	Clip, gel retainer	1
7	HW307	Screw, 8-32 x .38 lg, SPHMS, black zinc	4
8	HW370	Nut, 8-32, 3/8, 1/4, black zinc	4
9	HW3104	Washer, .170 x .381 x .023, black zinc	4
10	HW5197	Screw, 1/4, 20x58 PHRMS, black zinc	1
11	HW5200	Washer, SH, .253 x .281 x .438, black zinc	1
12	7060A4008	Knob, Z lamp, with male insert	1
13	HW5143	Washer, Fit. 1/4, .252 x .500 x .060, FL	1

5° Lens Tube

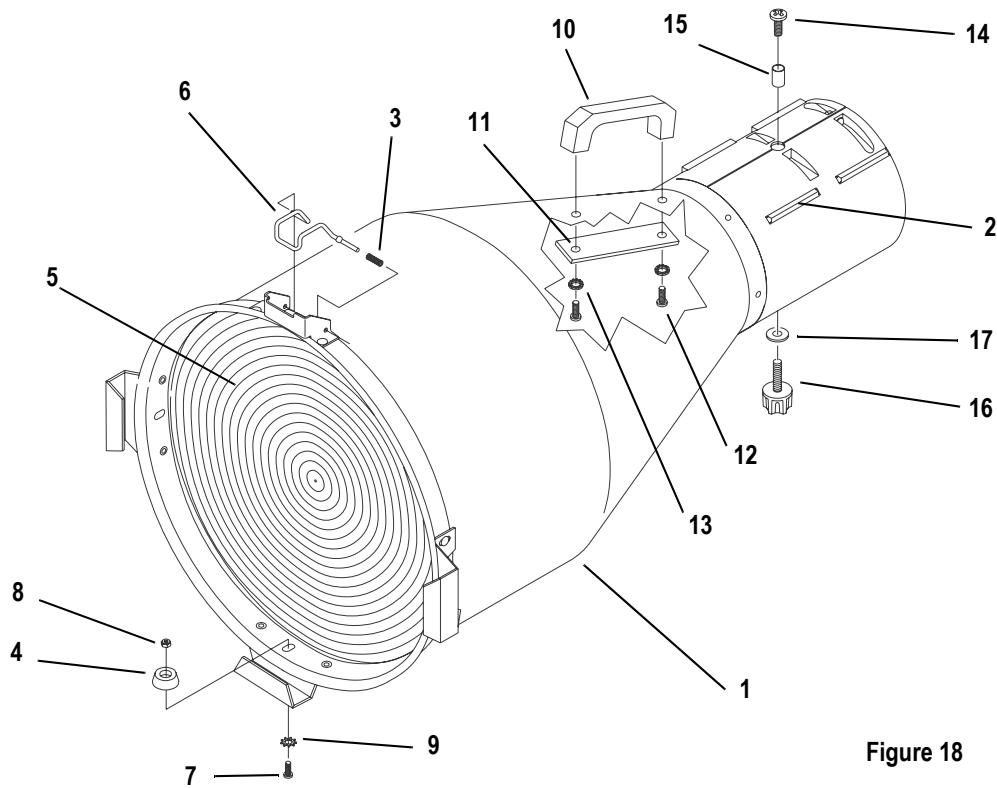

Figure 18

Reference Number	Part Number	Description	Quantity Required
1	7060A3095	5° lens tube assembly, painted	1
2	7060A4009	Bushing, guide	8
3	HW750	Spring, retainer	1
4	HW6122	Bumper, recess rubber	4
5	7060A4024	Lens, 5°, 10"	1
6	7060A3079	Clip, gel retainer	1
7	HW307	Screw, 8-32 x .38 lg, SPHMS, black zinc	4
8	HW370	Nut, 8-32, 3/8, 1/4, black zinc	4
9	HW3104	Washer, .170 x .381 x .023, black zinc	4
10	HW8170	Handle, 10-32 inserts	1
11	7060A3073	Handle backing plate	1
12	HW467	Screw, 10-32 x 1/2 PHTRMS	2
13	HW443	Washer, .195 x .410 x .025 black zinc	2
14	HW5197	Screw, 1/4, 20x58 PHRMS, black zinc	1
15	HW5200	Washer, SH, .253 x .281 x .438, black zinc	1
16	7060A4008	Knob, Z lamp, with male insert	1
17	HW5143	Washer, Flt. 1/4, .252 x .500 x .060, FL	1

Assemble 5° and 10° lens tubes

Tools Required:

- #2 Phillips head screwdriver

- Step 1: Place the lens tube assembly (1) on your work surface. Align the assembly so that the colorframe grooves are to your left.
- Step 2: If you are assembling a 5° tube, attach the handle (10) as shown in [Figure 18](#), using the screws (12), washers (13) and backing plate (11) indicated.
- Step 3: Install the required lens as shown on [page 15](#) or [page 16](#) in the tube using required bumpers (4), screws (7), nuts (8), and washers (9) as indicated. The side of the lens with the fresnel grooves should face the front of the tube. The smooth side should face the rear.

Clean 5° and 10° polymer lenses



WARNING: *Handle polymer lenses by their edges only. Never rub anything dry on a polymer lens. Do not use glass and window cleaners on the lens. This will damage the lens.*

Remove dust with a blast of oil-free air. If this is not sufficient, follow the instructions below.

- Step 1: Dip lens in clean alcohol/water solution (mix 9 parts water to 1 part alcohol).
- Step 2: Use a moistened, nylon, soft-bristle brush to wash the smooth side in a straight motion.
- Step 3: Use the same moistened brush to clean the ridged side, following the ridges, without hand pressure.
- Step 4: Dip lens in clean alcohol/water solution.
- Step 5: Use air gun to dry the smooth surface.
- Step 6: Use air gun to dry the ridged surface. Use air stream to move the liquid away from you. Using this method, remove as much liquid as possible.
- Step 7: Inspect the lens for dirt. If necessary, repeat the entire process.

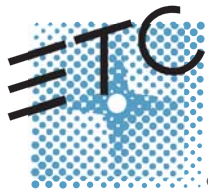

Corporate Headquarters ■ 3031 Pleasant View Road, P.O. Box 620979, Middleton, Wisconsin 53562-0979 USA ■ Tel +608 831 4116 ■ Fax +608 836 1736

London, UK ■ Unit 5, Victoria Industrial Estate, Victoria Road, London W3 6UU, UK ■ Tel +44 (0)20 8896 1000 ■ Fax +44 (0)20 8896 2000

Rome, IT ■ Via Ennio Quirino Visconti, 11, 00193 Rome, Italy ■ Tel +39 (06) 32 111 683 ■ Fax +39 (06) 32 656 990

Holzkirchen, DE ■ Ohmstrasse 3, 83607 Holzkirchen, Germany ■ Tel +49 (80 24) 47 00-0 ■ Fax +49 (80 24) 47 00-3 00

Hong Kong ■ Room 605-606, Tower III Enterprise Square, 9 Sheung Yuet Road, Kowloon Bay, Kowloon, Hong Kong ■ Tel +852 2799 1220 ■ Fax +852 2799 9325

Web: www.etconnect.com ■ **Email:** (Americas) mail@etconnect.com ■ (UK) mail@etceurope.com ■ (DE) info@ttlicht.com ■ (Asia) mail@etcasia.com

Service: (Americas) service@etconnect.com ■ (UK) service@etceurope.com ■ (Asia) service@etcasia.com ■ Comments about this document: techcomm@etconnect.com

7060M2500-05.02 ■ Rev B ■ Released 07/2006 ■ Copyright © 2005 ETC. All Rights Reserved. ■ Product information and specifications subject to change.