



0230-0252rB

PO BOX 4394  
SANTA ROSA, CA  
95402 USA

P (707) 525-9941  
F (707) 575-7046  
EMGPICKUPS.COM

## INSTALLATION INFORMATION EMG MODELS: J5, J5A, J5-CS SET (5-STRING)

### SPECIFICATIONS:

	MODEL:		
	J5	J5A	J5-CS
Logo Color	Silver	Gold	Silver
Magnet Type *	C	A	C/S
Resonant Frequency (KHz)	3.95	3.20	3.20
Output Voltage (String)	1.00	1.00	1.00
Output Voltage (Thump)	4.50	4.50	4.50
Output Noise (60 Hz)	-101	-99	-99
Output Impedance (Kohm)	10	10	10
Current @9V (Microamps)	80	80	80
Battery Life (Hours)	3000	3000	3000
Maximum Supply (Volts DC)	27	27	27

\*Note: Magnet Type: A (Alnico) C (Ceramic) C/S (Ceramic and Steel)

MAXIMUM RECOMMENDED STRING WIDTH 3.480" (88.4)  
FOR BOTH SJ5 AND LJ5 PICKUPS

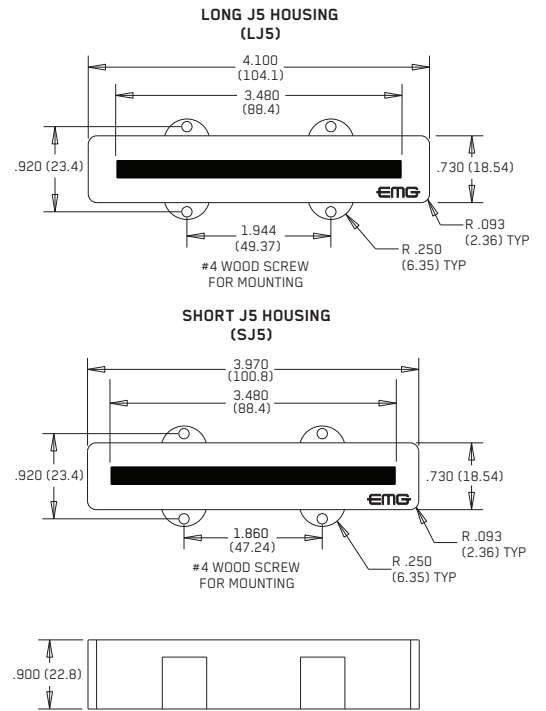

### PICKUP AND MAGNET DIMENSIONS:

The shorter housing (SJ) is for the neck pickup, while the longer housing (LJ) is for the bridge pickup. Both SJ and LJ Housings can work with both 4 and 5-string instruments, but you should check the width of your strings against the magnet dimensions above to make sure there is sufficient string coverage. A rule of thumb for any pickup is that the total magnet width should be the string width plus twice the distance the pickup is from the strings. So, if the pickup is 3/16" (5mm) from the strings, with a magnet width of 3.480" (88mm) the maximum string width would be 3.100" (79mm). If your string width is too wide for a J Pickup, choose one of the EMG Extended Series Pickups, with a 4 inch (100mm) housing.

### INCLUDED WITH EACH SET:

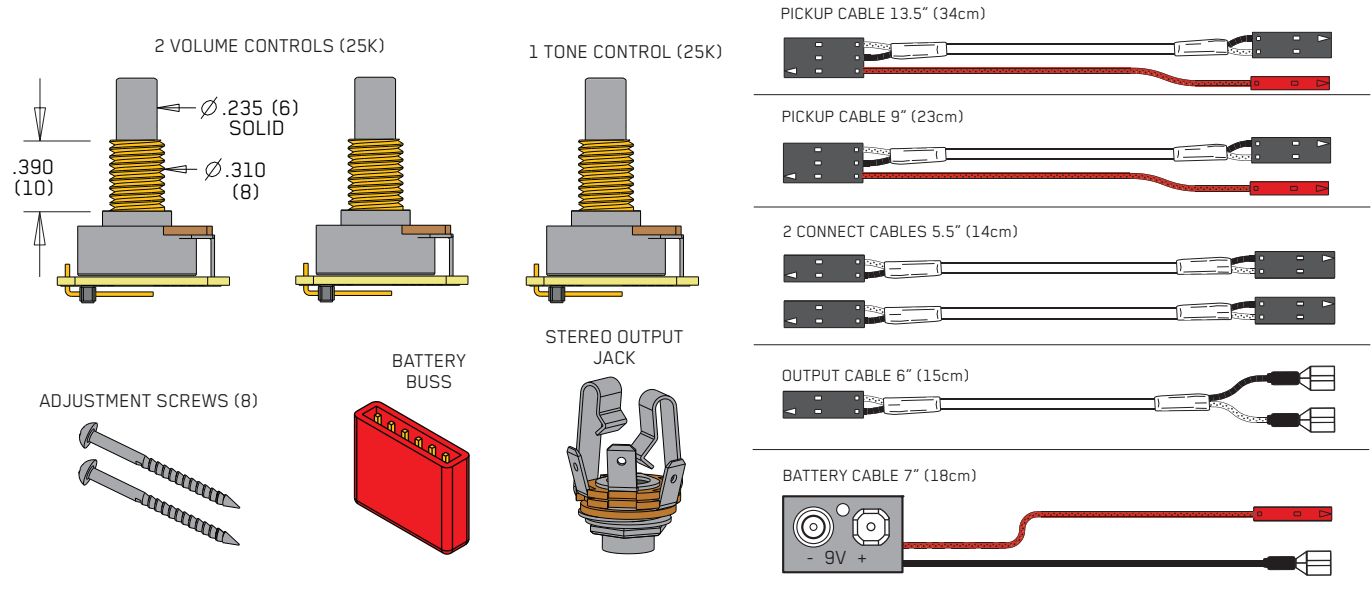

### WARRANTY

All EMG Pickups and accessories are warranted for a period of two years. This warranty does not cover failure due to improper installation, abuse or damage. If upon examination the pickup is determined to be defective, a replacement will be made. Warranty replacement products are covered by this same warranty. This warranty covers only those pickups and accessories sold by authorized EMG Dealers. This warranty is not transferable.

**Installation Instructions:**

**EMG Models: J5, J5A, J5-CS SET (5-STRING)**

**General Notes:**

- Every attempt has been made to make this a solderless installation. There are some instances where this is not possible;
- 1) If your instrument uses the long panel output jack and you had passive pickups you will need a new stereo output jack, the Switchcraft 152B is recommended. Soldering to the new jack will be required, see Diagram #5 on page 3.
  - 2) Power Supply tips are on page 4. If your instrument has a battery holder, you are installing this pickup with an older EMG, or you want to supply your instrument with +18 Volts, see page 4 for tips to avoid soldering.

- \*\*\*\*Tips and Tricks\*\*\*\* Start your installation by:**
- 1) Determine which type output jack your instrument has. A Stereo 12B type is Included, but if you have a long panel jack a SwitchCraft 152B Long Panel Jack will be required.
  - 2) Remove the strings, remove any existing Pickups and controls (remember the order and function of each control)
  - 3) Determine a good spot for the Pickup Buss and make sure the cable or wires from the selection switch will reach the Pickup Buss,
  - 4) Install the EMG Volume and Tone Controls and tighten them in.
  - 5) Then install the pickups keeping any excess cable under the pickup rather than in the control cavity.
  - 6) **IMPORTANT: EMG Active pickups do not require a string ground wire! DO NOT Reconnect the string ground, it is unnecessary.**

**Installation Instructions:**

**2 Pickups, 2 Volume controls and Master Tone, no selection switch**

**J-Bass Style wiring**

**Refer to Diagram #2**

- 1) Install the Pickups and route the Pickup cables to the control cavity. If the cables are too long, keep any excess under the pickup.
- 2) Mount the Volume and Tone controls into the body / pickguard. Plug the Neck Pickup Cable onto the Neck Volume Control. Plug the Bridge Pickup Cable onto the Bridge Volume Control.
- 3) Plug a coax cable from the Neck Volume Control to the Bridge Volume Control.
- 4) Plug a coax cable from the Bridge Volume Control to the Master Tone Control.
- 5) Plug the output cable onto the Master Tone control and connect the output wires to the output jack by pushing the connectors on as shown. WHITE wire onto the TIP (T) contact, BLACK wire onto the SLEEVE (S) contact, BLACK Battery Negative wire onto the RING (R) contact.
- 6) Plug the RED Wires of the pickups onto the V+ Supply Buss (RED Shroud) along with the RED of the battery clip.
- Extra pins on the V+ Supply Buss are for EMG Accessories.
- 7) Put the battery in the insulating foam piece provided and place it securely in the control cavity. We suggest that you plug in the instrument and test it before closing the control cavity.

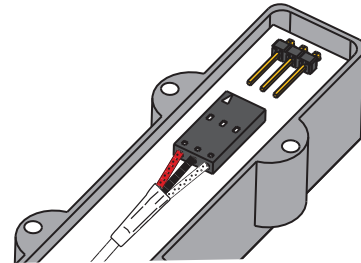

**Diagram #1**  
Insert the plug onto the 3 pin header of the pickup as shown above. Note the orientation arrow.

**Diagram #2**  
Volume / Volume  
Master Tone (Passive)

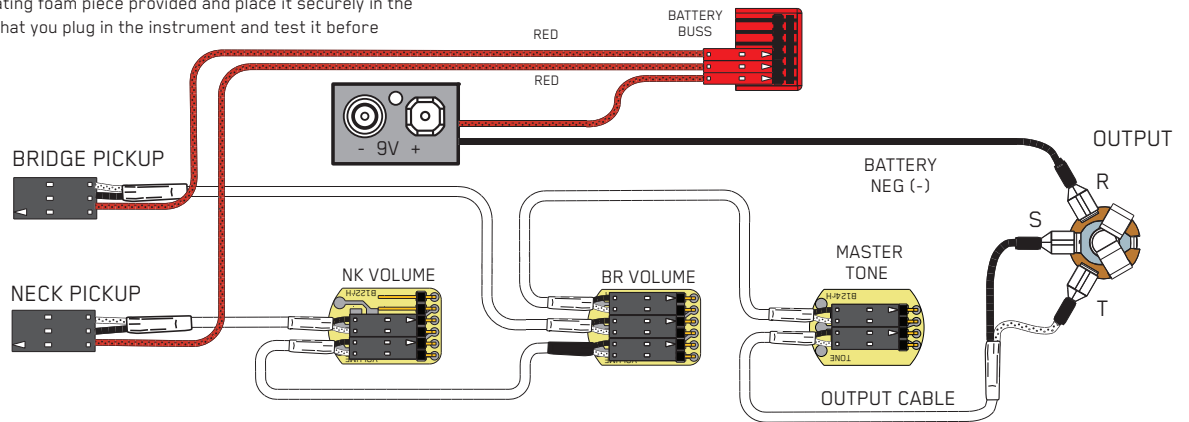

**Diagram #3 (preferred wiring order)**  
B125 Active Balance Control  
Active Tone / Master Volume

This installation can be used for instruments with 3 control positions like the diagram above, but use a Balance control instead of 2 Volume controls. The Active Tone Control shown in this diagram can be replaced with the EMG-EXB Expander, or the EMG-BTC Control (Active Bass and Treble EQ).

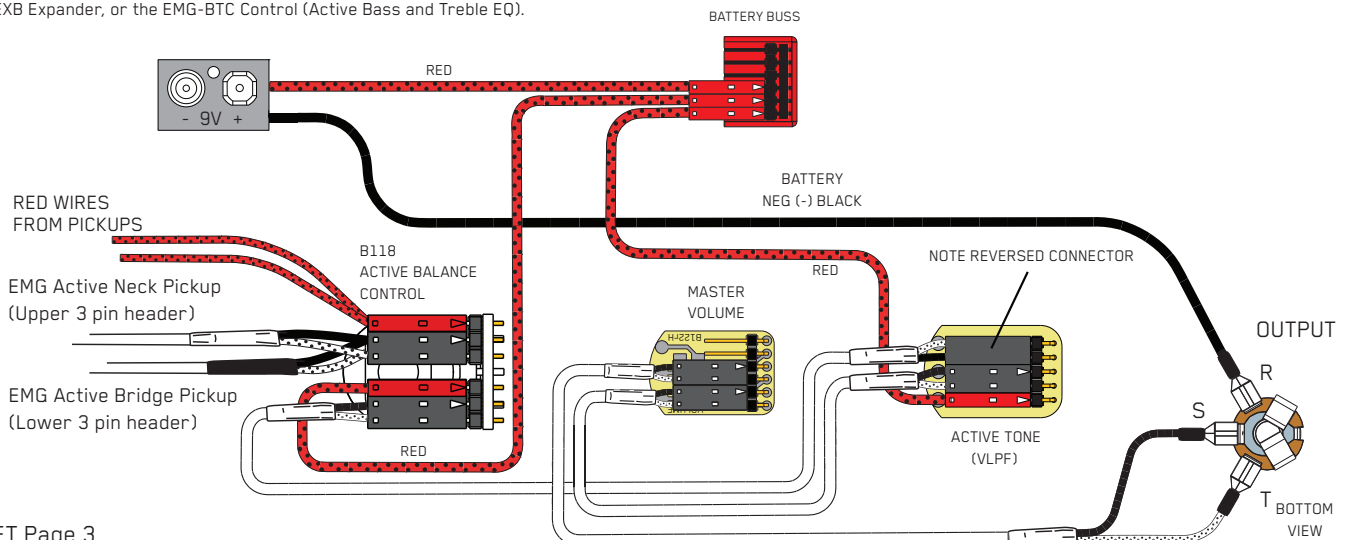
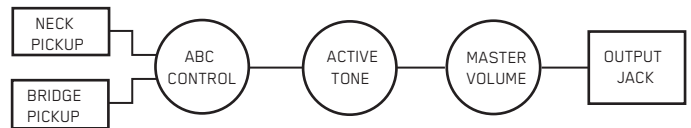

**Installation Instructions:**

**EMG Models: J5, J5A, J5-CS SET (4 /5-STRING)**

**If your instrument has a selection switch:**

Shown at the right is the EMG B245 Pickup Buss which is used for instruments that have 2 pickups and a 3 position selection switch. If you have a selection switch and want your installation to remain solderless, you'll need a B245 Buss.

Either send an e-mail to: sales@emgpickups.com or call: 800 821-1446 to get the buss.

- 1) Install the Pickups and route the Pickup cables to the control cavity. If the cables are too long, wind up the excess and keep it under the pickup.
- 2) Mount the Volume and Tone controls into the body. Plug both Pickup cables onto the Pickup Buss (BLACK Shroud) as shown, Refer to Diagram #4a  
 Bridge Pickup to position 1  
 Neck Pickup to position 2.
- 3) Plug a coax cable from the Pickup Buss (position 3) to the Master Volume control as shown in Diagram #4b.
- 4) Plug a coax cable from the Master Volume to the Master Tone as shown.
- 5) Strip the insulation from the switch wires and Insert them into the GREEN Terminal Block and tighten the screws with a small screwdriver.  
 The Bridge pickup goes to the BR Terminal  
 The Neck pickup goes to the NK Terminal  
 The Output of the switch goes to the O Terminal  
 If there is a ground wire coming from the switch, insert it into one of the black terminals on the terminal block.
- 6) Plug the output cable onto the Master Tone control and connect the output wires to the output jack by pushing the connectors on as shown.  
 WHITE wire onto the TIP (T) contact,  
 BLACK wire onto the SLEEVE (S) contact  
 BLACK Battery Negative wire onto the RING (R) contact.

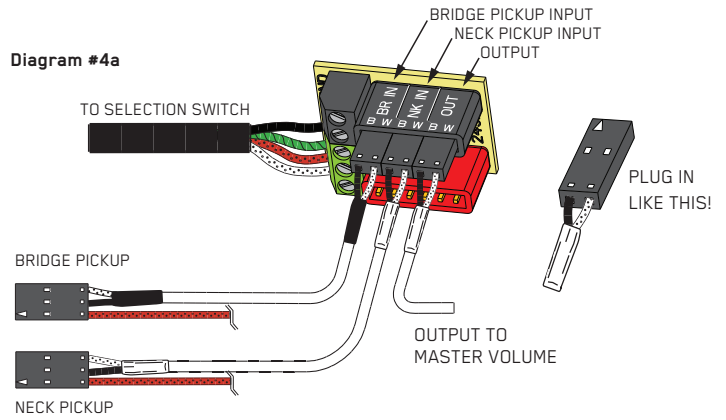

- 7) Plug the RED Wires of the pickups onto the V+ Supply Buss (RED Shroud) along with the RED of the battery clip.  
 Extra pins on the V+ Supply Buss are for EMG Accessories.
- 8) Put the battery in the insulating foam piece provided and place it securely in the control cavity.  
 We suggest that you plug in the instrument and test it before closing the control cavity.

**Diagram #4b**

- 2 Pickups
- 1 Master Volume
- 1 Master Tone
- Toggle Style Switch

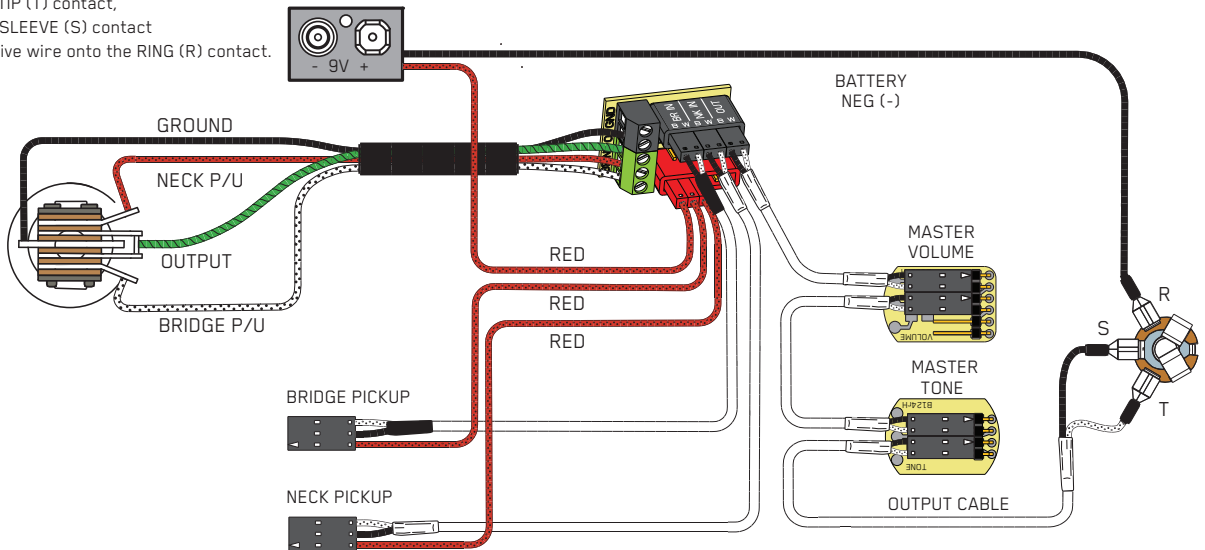
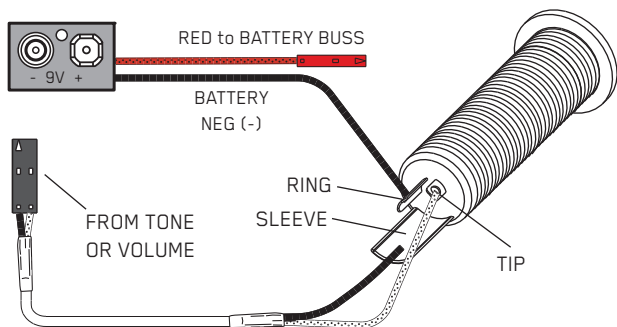

**Diagram #5**

**Soldering to the 152B Panel Jack:**

If your instrument has a long Panel Jack like the one below you will have to solder the output cable as shown.

- Ground (Black) to the sleeve
- Signal (White) to the Tip
- Battery Negative (Black) to the Ring



**Diagram #6**

**Soldering to the battery buss:**

If your instrument has an older EMG Pickup you can solder the pickup RED wire to the buss. Simply use some needle nose pliers, pull out the V+ header and solder the RED Wire from the pickup(s) to any of the pins and then re-insert the header into the housing.

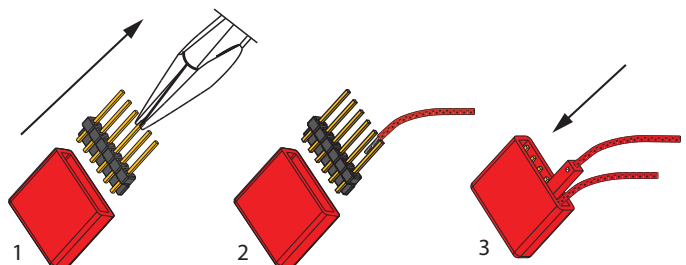

## 2 Pickups / Toggle Select Switch / 2 Volumes and 1 Tone)

Refer to Diagram #7

- 1) Install the Pickups and route the cables to the control cavity.  
If the cables are too long, wind up the excess and keep it under the pickup.
- 2) Mount the Volumes and Tone control into the body  
Plug both Neck and Bridge pickup cables onto the Volume Controls as shown.  
Plug a coax cable from the Bridge (BR) Volume control to the Pickup Buss (Position 1).  
Plug a coax cable from the Neck (NK) Volume control to the Pickup Buss (Position 2).
- 3) Plug a coax cable from Output of the Buss to the tone control.
- 4) Strip the insulation from the switch wires and insert them into the GREEN Terminal Block and tighten the screws with a small screwdriver.  
The Bridge pickup goes to the BR Terminal  
The Neck Pickup goes to the NK Terminal  
The Output of the switch goes to the O Terminal  
If there is a ground wire coming from the switch, insert it into one of the black terminals on the terminal block.
- 6) Plug the output cable onto the Pickup Buss (Out) and push the connectors onto the jack as shown.  
WHITE wire onto the TIP (T) contact,  
BLACK wire onto the SLEEVE (S) contact  
BLACK Battery Negative wire onto the RING (R) contact.

- 7) Plug the RED Wires of the pickups onto the V+ Supply Buss (RED Shroud) along with the RED of the battery clip. Extra pins are for EMG Accessories.
- 8) Put the battery in the foam insulator provided and place it securely in the control cavity.  
We suggest that you plug in the instrument and test it before closing the control cavity.

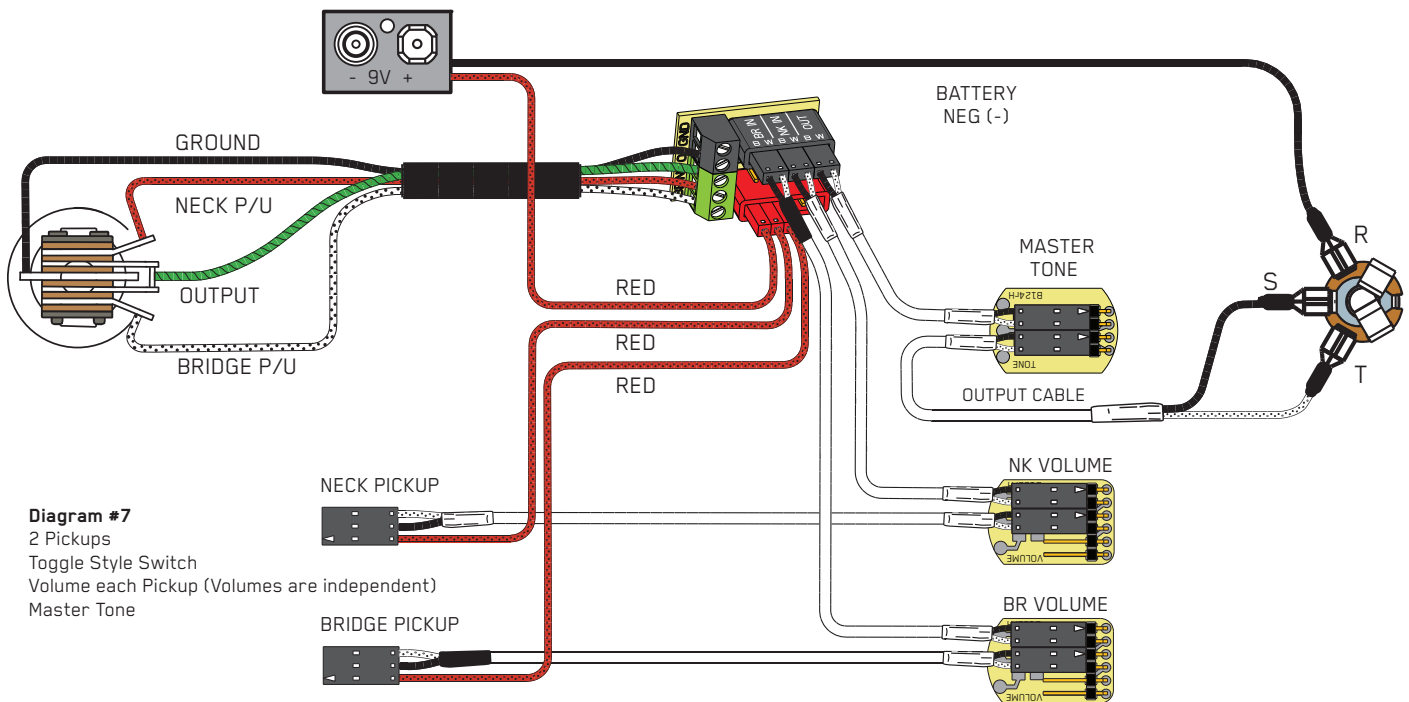

**Diagram #7**

2 Pickups  
Toggle Style Switch  
Volume each Pickup (Volumes are independent)  
Master Tone

**Diagram #8**

### If the instrument has a Battery Holder:

If your instrument has a 9 or 18 Volt battery holder you can still use the EMG Connectors to supply power to the pickups. Simply cut and strip the wires from the battery clip provided. Twist the wires together (Red to Red and Black to Black) and use the shrink tubing included to cover the connections. Soldering the wires is recommended.

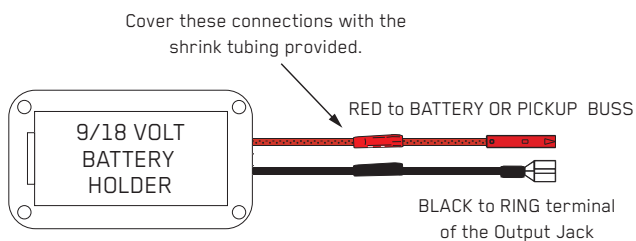

**Diagram #9**

### +18 Volt Wiring Option:

If you want to operate your instrument at +18 Volts for more headroom then use 2 batteries wired as below. Also, if you are using any type of EQ in your instrument (EMG-BT, BQ) or anything that boosts the pickup signal then +18 Volts is recommended.

