

dbx PROFESSIONAL PRODUCTS

ZonePRO

Digital Zone Processor

1260/1261



H A Harman International Company

User Manual

IMPORTANT SAFETY INSTRUCTIONS

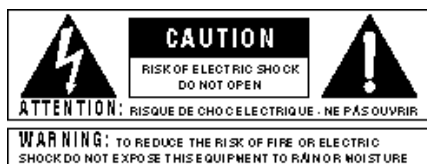

The symbols shown above are internationally accepted symbols that warn of potential hazards with electrical products. The lightning flash with arrowpoint in an equilateral triangle means that there are dangerous voltages present within the unit. The exclamation point in an equilateral triangle indicates that it is necessary for the user to refer to the owner's manual.

These symbols warn that there are no user serviceable parts inside the unit. Do not open the unit. Do not attempt to service the unit yourself. Refer all servicing to qualified personnel. Opening the chassis for any reason will void the manufacturer's warranty. Do not get the unit wet. If liquid is spilled on the unit, shut it off immediately and take it to a dealer for service. Disconnect the unit during storms to prevent damage.

SAFETY INSTRUCTIONS

NOTICE FOR CUSTOMERS IF YOUR UNIT IS EQUIPPED WITH A POWER CORD.

WARNING: THIS APPLIANCE MUST BE EARTHED. CONNECT ONLY TO A MAINS SOCKET OUTLET WITH PROTECTIVE EARTHING CONNECTION.

The cores in the mains lead are coloured in accordance with the following code:

GREEN and YELLOW - Earth BLUE - Neutral BROWN - Live

As colours of the cores in the mains lead of this appliance may not correspond with the coloured markings identifying the terminals in your plug, proceed as follows:

- The core which is coloured green and yellow must be connected to the terminal in the plug marked with the letter E, or with the earth symbol, or coloured green, or green and yellow.
- The core which is coloured blue must be connected to the terminal marked N or coloured black.
- The core which is coloured brown must be connected to the terminal marked L or coloured red.

This equipment may require the use of a different line cord, attachment plug, or both, depending on the available power source at installation. If the attachment plug needs to be changed, refer servicing to qualified service personnel who should refer to the table below. The green/yellow wire shall be connected directly to the units chassis.

CONDUCTOR		WIRE COLOR	
		Normal	Alt
L	LIVE	BROWN	BLACK
N	NEUTRAL	BLUE	WHITE
E	EARTH GND	GREEN/YEL	GREEN

WARNING: If the ground is defeated, certain fault conditions in the unit or in the system to which it is connected can result in full line voltage between chassis and earth ground. Severe injury or death can then result if the chassis and earth ground are touched simultaneously.

WARNING FOR YOUR PROTECTION

READ THESE INSTRUCTIONS:

KEEP THESE INSTRUCTIONS

HEED ALL WARNINGS

FOLLOW ALL INSTRUCTIONS

DO NOT USE THIS APPARATUS NEAR WATER

CLEAN ONLY WITH A DRY CLOTH.

DO NOT BLOCK ANY OF THE VENTILATION OPENINGS. INSTALL IN ACCORDANCE WITH THE MANUFACTURER'S INSTRUCTIONS.

DO NOT INSTALL NEAR ANY HEAT SOURCES SUCH AS RADIATORS, HEAT REGISTERS, STOVES, OR OTHER APPARATUS (INCLUDING AMPLIFIERS) THAT PRODUCE HEAT.

ONLY USE ATTACHMENTS/ACCESSORIES SPECIFIED BY THE MANUFACTURER.

UNPLUG THIS APPARATUS DURING LIGHTNING STORMS OR WHEN UNUSED FOR LONG PERIODS OF TIME.

Do not defeat the safety purpose of the polarized or grounding-type plug. A polarized plug has two blades with one wider than the other. A grounding type plug has two blades and a third grounding prong. The wide blade or third prong are provided for your safety. If the provided plug does not fit your outlet, consult an electrician for replacement of the obsolete outlet.

Protect the power cord from being walked on or pinched particularly at plugs, convenience receptacles, and the point where they exit from the apparatus.

Use only with the cart stand, tripod bracket, or table specified by the manufacture, or sold with the apparatus. When a cart is used, use caution when moving the cart/apparatus combination to avoid injury from tip-over.



Refer all servicing to qualified service personnel. Servicing is required when the apparatus has been damaged in any way, such as power-supply cord or plug is damaged, liquid has been spilled or objects have fallen into the apparatus, the apparatus has been exposed to rain or moisture, does not operate normally, or has been dropped.

POWER ON/OFF SWITCH: For products provided with a power switch, the power switch **DOES NOT** break the connection from the mains.

MAINS DISCONNECT: The plug shall remain readily operable. For rack-mount or installation where plug is not accessible, an all-pole mains switch with a contact separation of at least 3 mm in each pole shall be incorporated into the electrical installation of the rack or building.

FOR UNITS EQUIPPED WITH EXTERNALLY ACCESSIBLE FUSE RECEPTACLE: Replace fuse with same type and rating only.

MULTIPLE-INPUT VOLTAGE: This equipment may require the use of a different line cord, attachment plug, or both, depending on the available power source at installation. Connect this equipment only to the power source indicated on the equipment rear panel. To reduce the risk of fire or electric shock, refer servicing to qualified service personnel or equivalent.

This Equipment is intended for rack mount use only.

IMPORTANT SAFETY INSTRUCTIONS

ELECTROMAGNETIC COMPATIBILITY

This unit conforms to the Product Specifications noted on the **Declaration of Conformity**. Operation is subject to the following two conditions:

- this device may not cause harmful interference, and
- this device must accept any interference received, including interference that may cause undesired operation.

Operation of this unit within significant electromagnetic fields should be avoided.

- use only shielded interconnecting cables.

U.K. MAINS PLUG WARNING

A molded mains plug that has been cut off from the cord is unsafe. Discard the mains plug at a suitable disposal facility. **NEVER UNDER ANY CIRCUMSTANCES SHOULD YOU INSERT A DAMAGED OR CUT MAINS PLUG INTO A 13 AMP POWER SOCKET.** Do not use the mains plug without the fuse cover in place. Replacement fuse covers can be obtained from your local retailer. Replacement fuses are 13 amps and **MUST** be ASTA approved to BS1362.

DECLARATION OF CONFORMITY

Manufacturer's Name: dbx Professional Products
Manufacturer's Address: 8760 S. Sandy Parkway
Sandy, Utah 84070, USA

declares that the product:

Product name: dbx I260 and dbx I261
Note: Product name may be suffixed by the letters-EU.

Product option: None

conforms to the following Product Specifications:

Safety: IEC 60065 (1998)
EMC: EN 55013 (1990)
EN 55020 (1991)

Supplementary Information:

The product herewith complies with the requirements of the Low Voltage Directive 73/23/EEC and the EMC Directive 89/336/EEC as amended by Directive 93/68/EEC.

Vice-President of Engineering – Pro
8760 S. Sandy Parkway
Sandy, Utah 84070, USA

Date: August 23, 2004

European Contact: Your local dbx Sales and Service Office or

Harman Music Group
8760 South Sandy Parkway
Sandy, Utah 84070, USA
Ph: (801) 566-8800
Fax: (801) 568-7583

Introduction

0.1 ZonePro Features	ii
0.2 Service Contact Info	iii
0.3 Warranty	iv

Section 1 - Getting Started

1.1 Rear Panel Connections	2
1.2 (1260)Front Panel	3
1.3 (1261)Front Panel	3
1.4 ZonePRO Designer GUI	4
1.5 Software Installation	4

Section 2 - Software Overview

2.1 ZonePRO Philosophy	6
2.2 Views	6
2.3 Venue View Functions	6
2.4 Unit View Functions	8
2.5 Module View Functions	10

Section 3 - Software Operation

3.1 Overview	12
3.2 Connecting to the Device	12
3.3 Configuration Wizard	12
3.4 Parameter Editing	16
3.5 Storing Scenes	17
3.6 Scene Wizard	17
3.7 Schedule Wizard	18
3.8 File Save	18
3.9 Hardware Navigation	18

Section 4 - Detailed Parameters

4.1 Input	20
4.2 Parametric EQ	20
4.3 Advanced Feedback Suppression (AFS)	21
4.4 Automatic Gain Control (AGC)	23
4.5 Noise Gate	24
4.6 Compressor	25
4.7 De-Esser	27
4.8 Notch Filters	28
4.9 Router/Mixer	28
4.10 Auto Warmth	30
4.11 Band Pass Filter/Crossover	31

4.12 Output Dynamics	32
4.13 Delay	33
4.14 Output Polarity	33

Section 5- Application Guide

5.1 Restaurant Install	36
5.2 Health Club	38
5.3 Night Club	40

Section 6- Application Notes

6.1 Using the Input Link Bus	44
6.2 Using the ZC as a Scene Selector	44
6.3 Using the ZC-Fire	44
6.4 Using the Locate Function	45
6.5 Using the Address Network Wizard	45

Appendix

A.1 Factory Reset/Flash Update	50
A.2 Specifications	51
A.3 Block Diagram	52
A.4 Link I/O	53
A.5 Zone Controller Wiring and Install	54
A.6 Network Overview	57
A.7 Copyright	64

INTRO

CUSTOMER SERVICE INFO

Defining the
ZonePRO

WARRANTY INFO

dbx®

PROFESSIONAL PRODUCTS

INTRODUCTION

Congratulations on your purchase of the dbx® ZonePRO 1260 and/or 1261! The ZonePRO products are based on the same unparalleled design philosophy that made the DriveRack family famous. This philosophy, “To provide everything you need between the sources and the amplifiers,” creates a full featured processor capable of almost any BGM or commercial audio application.

This manual will be your guide to understanding the full functionality of the powerful ZonePRO units. By combining the different components, the configuration possibilities are limitless. After you have become familiar with the unit, we encourage you to experiment and find the most effective and efficient way to run your system by utilizing the powerful processing of the ZonePRO 1260 and 1261.

0.1 - ZonePro Features**ZonePRO 1260/1261 features:**

- *Individual Zone Routing or Mixing*
- *Advanced Feedback Suppression (AFS™)*
- *AutoWarmth®*
- *Auto Gain Control*
- *Compression*
- *Limiting*
- *Noise Gating*
- *Notch Filtering*
- *Bandpass and Crossover Filters*
- *Parametric EQ*
- *Security Lockout*
- *Wall Panel Control*
- *RS-232 and Ethernet Control*
- *IEC, UL, and CSA Certified*

In addition to the processing available, the ZonePRO units provide intuitive wall-panel control from the dbx Zone Controller (ZC) series. The ZC-1 and ZC-6 offer remote programmable Volume control to any installation using the ZonePRO units. The ZC-2 provides programmable Volume and Mute control. The ZC-3 and ZC-4 allow Source selection, Scene selection or Page steering. ZC-FIRE provides an interface for fire safety systems. The ZC-7 remote offers page steering from a programmable push button interface. The ZC-8 provides a single panel with both push button volume control and source selection. The ZC-9 provides source selection. Up to 12 Zone Controllers can be used with a single ZonePRO, and can either be wired in series or parallel. The ZC-BOB was created to accommodate “home-run” or parallel wiring to the unit. With a maximum length of 1,000 ft., the Zone Controllers offer a simple way to create a simple yet elegant solution to many installation applications.

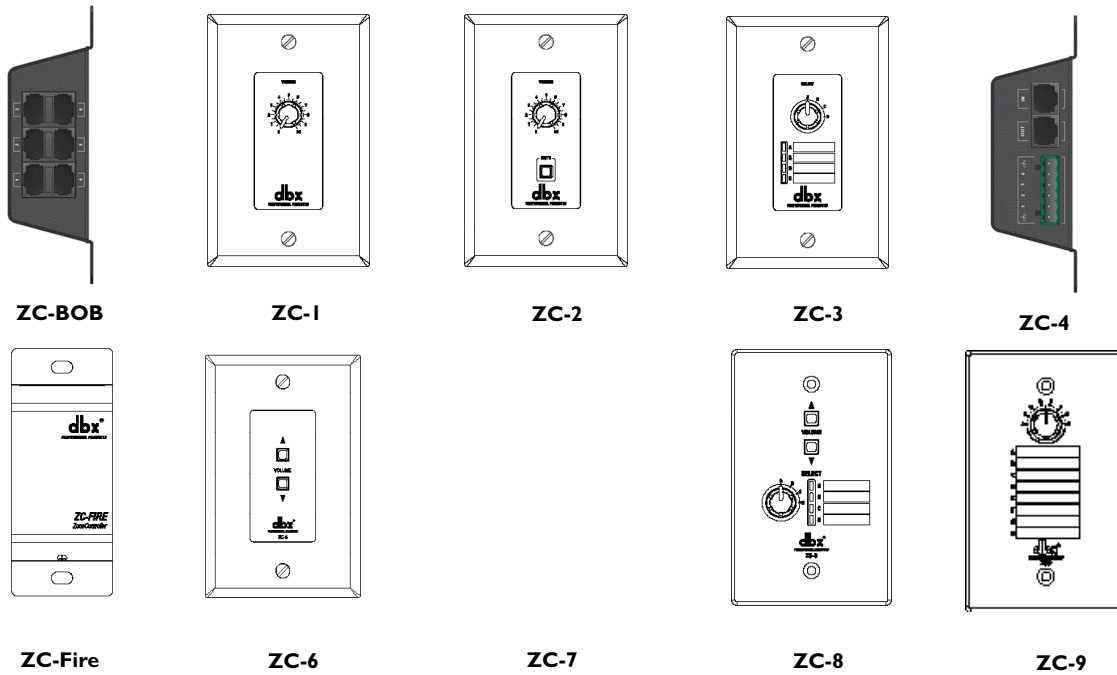

0.2 - Service Contact Info

If you require technical support, contact dbx Customer Service. Be prepared to accurately describe the problem. Know the serial number of your unit - this is printed on a sticker attached to the top panel. If you have not already taken the time to fill out your warranty registration card and send it in, please do so now.

Before you return a product to the factory for service, we recommend you refer to the manual. Make sure you have correctly followed installation steps and operation procedures. If you are still unable to solve a problem, contact our Customer Service Department at (801) 568-7660 for consultation. If you need to return a product to the factory for service, you **MUST** contact Customer Service to obtain a Return Authorization Number.

No returned products will be accepted at the factory without a Return Authorization Number.

Please refer to the Warranty information on the following page, which extends to the first end-user. After expiration of the warranty, a reasonable charge will be made for parts, labor, and packing if you choose to use the factory service facility. In all cases, you are responsible for transportation charges to the factory. dbx will pay return shipping if the unit is still under warranty.

Use the original packing material if it is available. Mark the package with the name of the shipper and with these words in red: DELICATE INSTRUMENT, FRAGILE! Insure the package properly. Ship prepaid, not collect. Do not ship parcel post.

0.3 - Warranty

This warranty is valid only for the original purchaser and only in the United States.

1. The warranty registration card that accompanies this product must be mailed within 30 days after purchase date to validate this warranty. Proof-of-purchase is considered to be the burden of the consumer.
2. dbx warrants this product, when bought and used solely within the U.S., to be free from defects in materials and workmanship under normal use and service.
3. dbx liability under this warranty is limited to repairing or, at our discretion, replacing defective materials that show evidence of defect, provided the product is returned to dbx WITH RETURN AUTHORIZATION from the factory, where all parts and labor will be covered up to a period of two years. A Return Authorization number must be obtained from dbx by telephone. The company shall not be liable for any consequential damage as a result of the product's use in any circuit or assembly.
4. dbx reserves the right to make changes in design or make additions to or improvements upon this product without incurring any obligation to install the same additions or improvements on products previously manufactured.
5. The foregoing is in lieu of all other warranties, expressed or implied, and dbx neither assumes nor authorizes any person to assume on its behalf any obligation or liability in connection with the sale of this product. In no event shall dbx or its dealers be liable for special or consequential damages or from any delay in the performance of this warranty due to causes beyond their control.

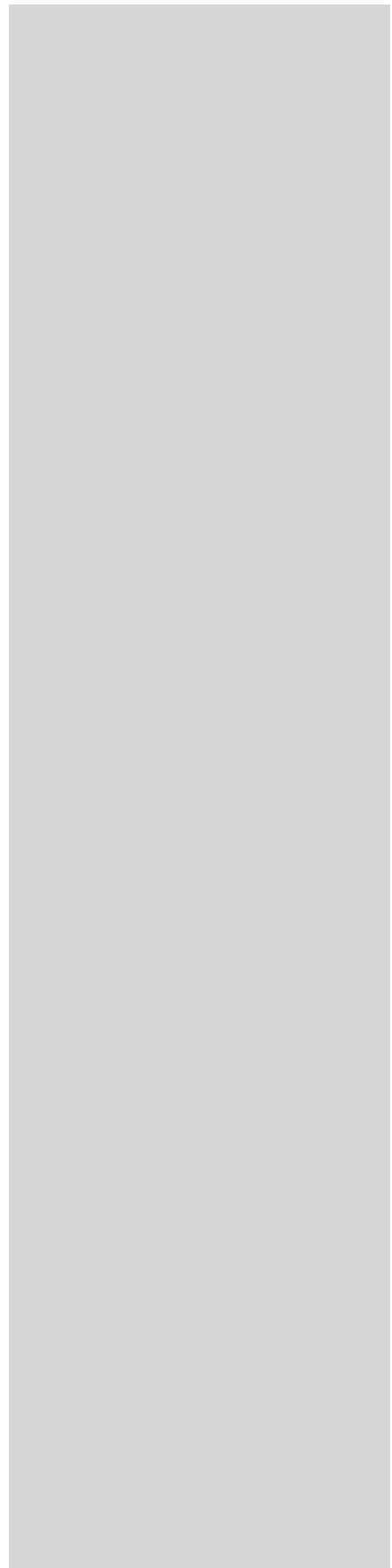

1.1 - Rear Panel (1260 and 1261)

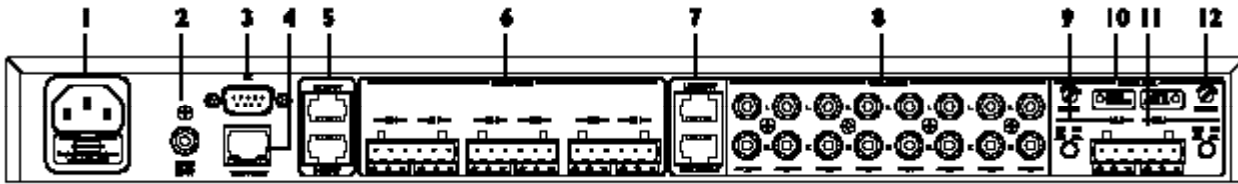

1. IEC Power Cord Receptacle

The ZonePRO 1260/1261 comes with a power supply that will accept voltages ranging from 100V-240V at frequencies from 50Hz-60Hz. An IEC cord is included.

2. S/PDIF Connection

This RCA connection is used to connect up to two digital input channels in the 1260/1261.

3. PC Connection (DB-9)

This DB-9 connection is used to communicate to the PC GUI and uses RS-232 protocol. This connection requires a Null modem cable and one is included with the ZonePRO unit.

4. Ethernet Connection (RJ-45)

This RJ-45 connection is used to control the unit via Ethernet.

5. Zone Control Inputs 1-12 (RJ-45)

This input connection is used to send information and power to the ZC wall controllers.

6. Outputs Channels 1-6 (Euroblock)

The output section of the ZonePRO offers six electronically balanced Euroblock connectors.

7. Input Link Buss (RJ-45)

The ZonePRO offers an input buss that duplicates the first six inputs from one unit to the next for applications requiring more than six output zones.

8. Input Source Channels 1-8 (RCA)

The input section of the ZonePRO offers eight mono-summing unbalanced RCA connectors.

9. Line/Mic Selector

This switch is used to select either the line or microphone input.

10. Signal/Clip LED

This LED is used to indicate microphone signal input or clip.

11. Mic/Line Inputs 1-2 (Euroblock)

The input section of the ZonePRO provides two Euroblock connectors for mic/line inputs.

12. Mic Gain Control

This knob is used to set the input gain for the microphone input.

1.2 - Front Panel (1260)

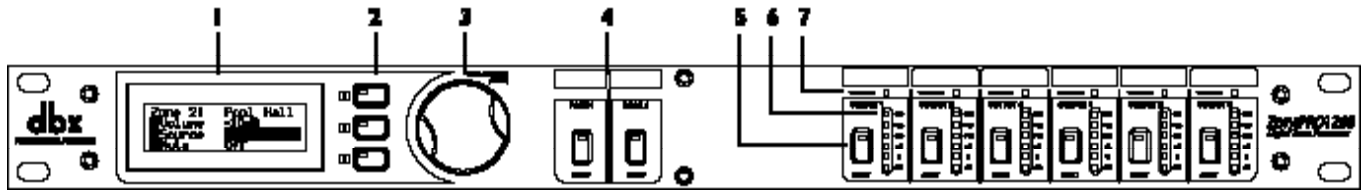
**1. LCD Display**

The backlit LCD display of the ZonePRO 1260 provides the end-user with all the necessary controls including source selection, page steering, zone volume and mute.

2. Parameter Select 1-3

These three buttons are used to select and edit parameters.

3. Data Wheel

The Data Wheel is used to edit parameter values.

4. Page Buttons 1-2

The Page buttons are used to select the page mic path and steer it to selected zones.

5. Zone Select

These buttons are used to select output zones for front panel control.

6. Output Meters

The ZonePRO 1260 provides the user with six independent six-segment Lightpipe output meters that range from -30 to +20 dBu.

7. Threshold Meters

The threshold meters indicate that the threshold level has been exceeded within the output Compressor, Auto Gain Control, or Limiter sections, and gain reduction may be taking place.

1.3 - Front Panel (1261)

1. PC Connection

This DB-9 connection is used to communicate to the PC via RS-232 protocol.

2. Network Traffic LED

This LED is used to indicate Network Traffic; it is also used to indicate and identify the unit when the Locate function is enabled.

3. Power LED

This LED (when lighted), indicates that the ZonePRO 1261 is currently powered.

1.4 - ZonePRO Designer GUI

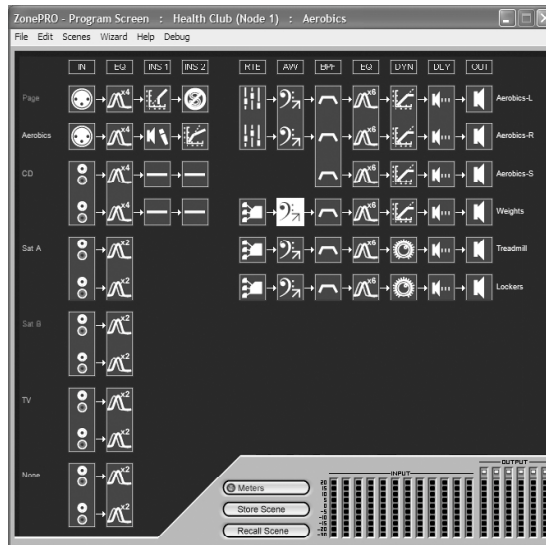

The ZonePro Designer Graphic User Interface (GUI) provides all the control functions necessary to configure and program the ZonePro products. The GUI provides network tools for configuring your control network as well as multiple “Wizard” functions for configuring the system routing, implementing end-user control surfaces, programming parameters, and even creating automatic system changes. Understanding the ZonePro Designer software is the key to getting full functionality from ZonePro products.

1.5 - Software Installation

Minimum System Requirements for ZonePRO Designer are:

- 1 GHz or faster processor
- Windows 2000 or XP
- 256 MB RAM or (512 MB Recommended)
- Recommended screen resolution: 1024 x 768 pixels or higher

Installation

- Install the ZonePRO GUI software from either the dbx website at www.dbxpro.com or from the included CD ROM onto your computer.
- Once the software setup is downloaded, double click on the file named: ZonePRO_setup.
- The application will proceed to prompt you for the installation location.
- Once the software installation has been completed, it is recommended that you restart your computer.

Note

You must disable virus protection software during the installation of ZonePRO Designer.

**SOFTWARE
OVERVIEW**

For your convenience, all the configuration and editing features of the ZonePRO™ 1260 and 1261 are performed via the included ZonePRO Designer GUI. This section has been created to act as a tutorial for performing various editing aspects of the unit.

2.1 - ZonePRO Philosophy

The philosophy of the ZonePRO Designer and the files that it creates, are built around the concept of a configuration, a scene and a device file; all of which are found in the Unit View (Please see below).

Configuration

The configuration includes all of the processing blocks, the I/O configuration, and the zone controllers. The configuration is set up by going through the Configuration Wizard. The ZonePRO device can only have one configuration, so all configuration editing must be completed before you can store any scenes. For more information on the configuration see Configuration Wizard in section 3.3.

Scenes

A scene consists of the parameters for all the modules and the assignment of zone controllers to a zone. The ZonePRO products allow switching of scenes from the Real Time Clock, or from a ZC zone controller. Up to 50 scenes can be stored in the ZonePRO unit. Scenes can be stored by clicking on the Store Scene button in the Unit view. For more information on scenes, see section 3.5.

Device

The configuration, scenes, and schedule information can all be stored off to a device file or .zpd (ZonePRO device). Storing a device file to the computer and then recalling it into another ZonePRO unit allows for exact duplication of a system in a single file download. The device file can be stored by selecting File Save in the Unit view.

2.2 - Views

There are three different views within the ZonePRO Designer GUI; Venue view, Program screen, and Module view. **Venue view** Venue View gives you a global view of the network including all your units if you are using Ethernet control. Double clicking on a unit icon in the Venue view take you to the Unit view. **Unit View** (sometimes called **program screen**) provides you with a graphic representation of the configuration of the individual ZonePRO unit, including all the processing modules and their positions in the signal path. The program screen also offers access to meters, scene storing and loading, the Wizard functions, and file storing. Double clicking on the processing modules take you to the Module view. **Module view** (also called **edit screen**) provides access to the processing parameters. Editing of parameters is done in Module view.

2.3 - Venue View Functions

2.3.1 Device Menu

The ZonePRO Designer GUI provides a mechanism for creating scenes and device files while not physically connected to a ZonePRO unit. To work off-line, open the GUI, select the Device Menu from the menu bar then select **Add**. At this point you will be prompted to choose a 640, 641, 1260 or 1261. Once the unit has been inserted into GUI you can proceed to configure, edit, create scenes, and save ZonePRO device files. If you highlight the ZonePRO unit and select **Edit**, you will be taken to the Unit view so that you can edit the

unit; double clicking on the unit also takes you to the Unit view. When off-line, You can delete the unit by selecting **Delete** from the Device Menu. Selecting **Properties** from the Device menu allows you to view and edit some of the device properties like the device's name, its MAC address, Its Node address, and its peak output level. From the **Properties** selection, you can also see the firmware or OS (Operating System) version that the device has loaded

2.3.2 Network Menu

The Network Menu provides access to network parameters. If the computer cannot connect to the ZonePro device you can select **Properties** from the Network Menu and check the COM port assignment to make sure that you are connecting to the correct COM port. The Network Menu also provides an **Address Tool** that can be used to discover other devices on the network and resolve any address conflicts that may arise between units.

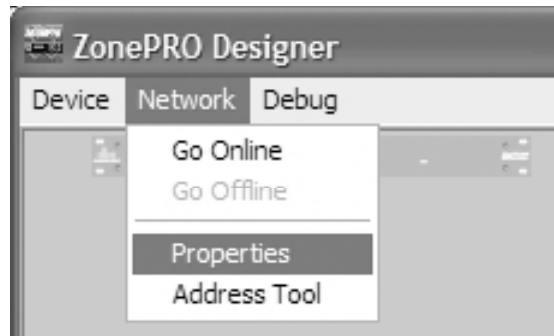

Note: Nodes

Any device that is on the network is considered a node and must be given a node address; this is just usually a simple one or two digit number. Once you place the first device on the network the GUI will assist you as you add further devices by adding 1 to the previous node address as you add devices. For example, if the first device on the network is node address 1, the second will be 2, and the third 3, unless you specifically change the node address with the Network Address Tool. If the computer cannot connect to the ZonePRO device, check the COM port assignment under Network Properties in the Venue View, and make sure that you are connecting to the correct COM port.

Note: Setting up a basic Network

The enclosed crossover Ethernet cable is used to connect a computer directly to a ZonePRO 1260/1261 without a hub or a switch. If you are using a hub or a switch, you must provide your own cabling. Since this cable is a crossover cable, it can not be used to wire Zone Controllers or link to multiple ZonePRO units together using the Input Link Bus.

The factory default IP settings for the ZonePRO are as follows:

IP Address:	169.254.2.2
Subnet Mask:	255.255.0.0
Default Gateway:	0.0.0.0

These default settings are used for a simplified configuration when using Microsoft Windows's Automatic IP assignment. When Windows is configured to automatically obtain its IP settings it will fall back to a network configuration that is compatible with the ZonePRO 1260 / 1261 if the computer is on a network without a DHCP/BOOTP server. Using the enclosed crossover cable is an example of such a network and is the recommended method of configuring a new unit. Please keep in mind that it takes MS Windows 1-2 minutes after the cable is attached and the ZonePRO is powered on for it to have its network settings compatible with the ZonePRO. Because of this, do not start the ZonePRO Designer software for about 2 minutes after the cables have been attached. For more information on how to properly configure the network setting please refer to the appendix.

2.4 - Unit View Functions

The Unit View provides access to the signal routing configuration, Zone Controller assignment, and processing parameters.

2.4.1 File Menu

The File Menu selection allows saving of the existing ZonePRO device file (.zpd) as well as recalling of other files. The device file provides a way to store off the entire ZonePRO unit to a computer, which includes the configuration, scenes, and schedule information. To save a ZonePRO device file, select **File** then **Save** from the Menu bar. Recalling a saved file can be done by selecting **Open** from the File Menu. Once all of your changes have been made, simply close the file with the **Close** selection.

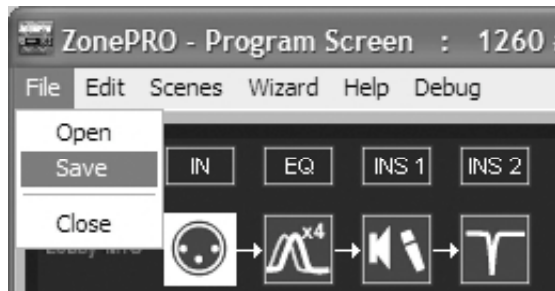

2.4.2 Edit Menu

To edit a processing module, double click on that module. Adjust the module to taste; make sure that the module is engaged. This is usually indicated by the module **ON** button in the upper left corner of the parameter section. Although process editing is done in real-time, the changes can either be discarded or accepted by selecting the **OK** or **CANCEL** button. Parameters can be copied and pasted between like modules in the ZonePRO GUI. From the program screen either right click on the module and select Copy, or select Edit and Copy from the Menu Bar to Copy parameters. To paste, either right click and select Paste, or click on Edit Paste from the Menu bar. Selecting **Time** in the Edit Menu allows editing of the date and time in the ZonePRO device's real time clock

2.4.3 Scenes Menu

Scenes include parameter data and zone controller assignment. Multiple scenes can be saved and recalled by either clicking on the Scene tab of the Menu bar and selecting Store or Recall Scene, or by using the Store Scene and Recall Scene buttons at the bottom of the Unit view window.

2.4.4 Wizard Menu

The Wizard Menu provides setup functions for the unit configuration, scene changes that might involve routing or ZC assignment changes, and automated scene changes via the real time clock schedule. Configuration of the ZonePRO device is done from the Configuration Wizard and allows setup of the inputs and outputs along with selection of their processing modules, zone controller setup, signal routing, and front panel setup. For a detailed operation description see "The Wizard" section 3.3. The image on the following page shows the first page of the Configuration Wizard page.

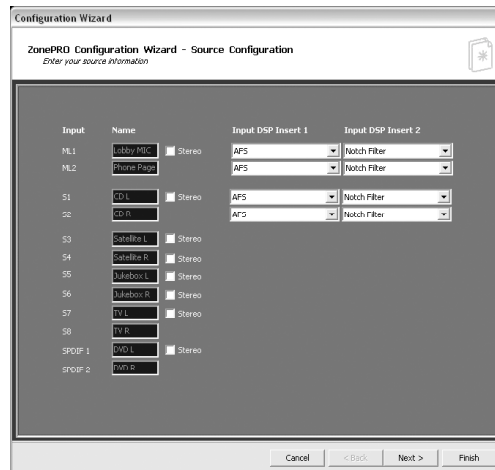

The Scene Wizard allows routing and ZC assignment changes for different scenes. Scheduling Scene Changes is done using the Schedule Wizard. Selecting the Schedule Wizard from the Wizard Menu reveals the image below where scenes can be recalled at various times throughout the day or week.

2.4.5 Help Menu

The Help Menu provides for some special functions like retrieving **Hardware Info** such as Checksum and Fire Safety status. There is a **Locate** function similar to the Locate function found under the Device Menu in the Venue view. A special provision for the 641 and 1261 is found in the Help menu under **641/1261 Operations** that can be used to do hard or soft resets on those units if the need arises. Finally the GUI software version is found under **About** in the Help menu.

2.4.6 Meters Button

The Meters Button, found at the bottom of the Unit view can be used to turn the meters off. Turning the meters off will help speed the communication and processing of slower computer systems. The ZonePRO Designer GUI defaults with the meters turned on.

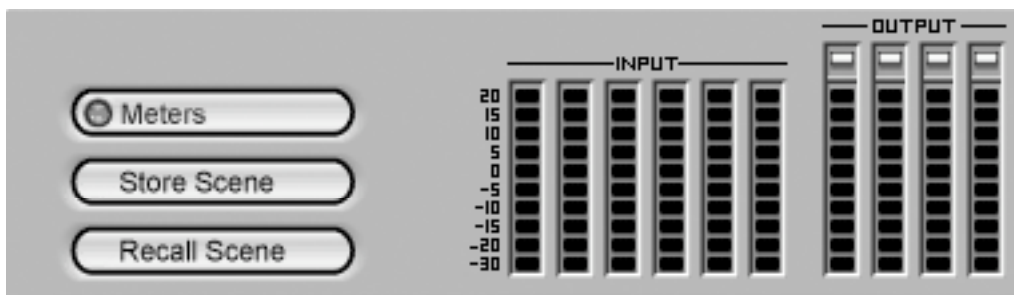

2.5 - Module View Functions

Double clicking on a processing module provides access to those parameters. All modules except for the input Gain module and the output Polarity have ON/OFF buttons allowing the processing of that module to be bypassed. Any changes made to the processing happen in real time as long as the ON/OFF button is turned on (indicated by the button turning red). These changes can be accepted or discarded upon exiting the module by selecting either the OK or CANCEL button at the bottom of the module view.

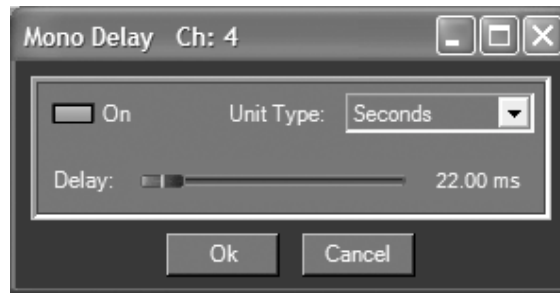

**SOFTWARE
OPERATION**

3.1 - Overview

The Software operation section of the manual will provide in-depth step by step instructions for setting up a ZonePro 1260 or 1261 and any Zone Controllers that may be used with it. The following subsections will provide you with detailed information regarding the various set up functions. Typical procedure of a ZonePro 1260 is as follows:

Step 1, Connect to the Device - Use either RS-232 or Ethernet to connect to the ZonePro unit.

Step 2, Configuration Wizard - Once you have connected to the device you can begin to configure the signal routing, DSP functions, and wall panel controllers using the Configuration Wizard.

Step 3, Parameter Editing - Double clicking on the various modules allows editing of parameters to adjust settings for individual installations or scenes.

Step 4, Scene Storing - Whether using a single scene or many, **storing the scene is important to make sure that all parameter changes are saved.** If just one scene is desired you can save it as the Default scene.

Step 5, Scene Wizard - If multiple scenes are desired with routing or zone controller assignment changes, use the Scene Wizard to make those changes. Repeat Steps 3 and 4.

Step 6, Schedule Wizard - If multiple scenes are to be loaded using the Schedule function, set up the Schedule using the Schedule Wizard for each scene change. Make sure the clock is correct by clicking on Edit then Time from the Menu Bar.

Step 7, File Save - It is recommended that you save off a copy of your ZonePRO device file using the File Save on the Menu bar. This file is a back-up and might come in handy for future installations.

3.2 - Connecting to the Device

If you are connecting to a device with an RS-232 connection the connection should be established fairly quickly. If you have difficulty connecting to the ZonePRO unit you can use the Network Wizard to select the proper COM port.

If you are using your Ethernet port on your computer this may take up to two minutes as Windows tries to first establish an Ethernet connection. If after two minutes your computer cannot connect to the ZonePro device you may want to select NETWORK/GO OFFLINE wait ten seconds then select NETWORK/GO ONLINE from the Venue view.

If you are setting up a larger network with multiple devices, please see Appendix for more information.

3.3 - Configuration Wizard

The Wizard function is used to configure the ZonePRO signal routing, processing modules, Zone Controllers and Front Panel. It provides a menu based decision tree to speed setup. This sub-section will walk you through each page of the Wizard function.

From the Program Screen view of the setup, select the **Wizard** pull down from the menu bar and then select the option labeled **Configuration Wizard**. Once selected, a window will appear as follows:

3.3.1 Source Configuration

This page is the Input Setup Page, and allows naming of inputs, input configuration (mono or stereo), and selection of the two mic/line DSP modules. Once you have named your inputs and selected insert modules, click on the **Next Page** button and the display will appear as follows:

The screenshot shows a software window titled "Configuration Wizard" with a sub-header "ZonePRO Configuration Wizard - Zone Configuration". Below the sub-header is the instruction "Enter your zone configuration information". The main area contains a table with four columns: "Name", "Router/Mixer Select", "Crossover Configuration", and "Output DSP Insert". There are six rows of output channels, each with a text input field for the name, two radio buttons for "Route" and "Mx", a dropdown menu for "Crossover Configuration", and another dropdown menu for "Output DSP Insert". At the bottom of the window are four buttons: "Cancel", "< Back", "Next >", and "Finish".

Output Channel	Name	Router/Mixer Select	Crossover Configuration	Output DSP Insert
Output Channel 1:	Lobby	<input checked="" type="radio"/> Route <input type="radio"/> Mx	Mono	Automatic Gain Control
Output Channel 2:	Bar	<input checked="" type="radio"/> Route <input type="radio"/> Mx	Mono	Automatic Gain Control
Output Channel 3:	Dining	<input checked="" type="radio"/> Route <input type="radio"/> Mx	Mono	Automatic Gain Control
Output Channel 4:	Patio	<input checked="" type="radio"/> Route <input type="radio"/> Mx	Mono	Automatic Gain Control
Output Channel 5:	Lounge	<input checked="" type="radio"/> Route <input type="radio"/> Mx	Mono	Automatic Gain Control
Output Channel 6:	Deck	<input checked="" type="radio"/> Route <input type="radio"/> Mx	Mono	Automatic Gain Control

3.3.2 Zone Configuration

This page is the Output Setup Page and allows naming of the outputs, zone configuration, and selection of the Dynamics DSP module. The outputs can be configured as mono, or stereo either with or without a subwoofer. You can also select whether you want a mixer or routing module as part of your zone. Once you have performed all of your output setup modifications, click on the **Next Page** button and the display will appear as follows:

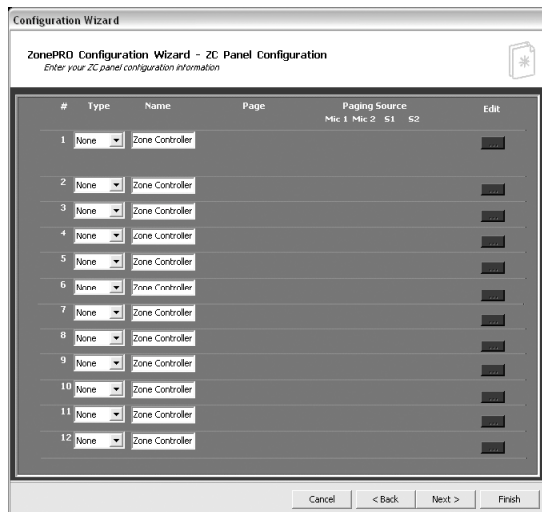

3.3.3 ZC Panel Configuration

The ZC Panel Configuration Page allows setup of wall-mounted Zone Controllers to be used with the ZonePRO unit.

ID #s - The ID numbers on the left side of the window correspond to the identification number set using the DIP switches on the individual zone controllers. To select ID#2 for example, simply flip the 2 switch into the on position. ID 1-6 are connected to one of the ZC inputs on the rear panel and ID 7-12 are connected to the other input. For ID 7-12 add 6 to the ID # selected on the back of the ZC. For example, to get an ID# of 10, connect to ZC Input 7-12 and set the ID# to 4.

Types - The zone controllers can be named to eliminate confusion in later menus. Since several zone controllers have multiple functions examples of each function will be shown: Scenes - To change scenes a ZC-3 or ZC-4 must be used in the ID #1 position. This zone controller must have the scene check box checked. Select the desired scenes from the list of scenes on the right hand side of the window and associate it with the selector position A, B, C, D on a ZC-3 or switch position 1-16 on a ZC-4 (see ZC-4 switch positions within the Appendix). Fire - The ZC-FIRE is a special case of scene selection. A ZC-FIRE can only be assigned to ID #2. Select whether the ZC-FIRE should be activated when taken high or low. Select to either Mute all outputs, or select the desired scene to be loaded.

Name - The zone controller can be named to eliminate confusion in later menus.

Page - If Page steering is desired, a ZC-3, ZC-4 or ZC-7 must be used. To select Page steering, select the Page box on the ZC-3 and 4, the ZC-7 will come up with the Page box automatically selected. Then select the Paging source from Mic 1, Mic 2, S1 or S2.

Edit - Setting parameters for the Zone Controllers is done by clicking on the Edit button.

Edit - Volume - A ZC-1, ZC-2, ZC-6, or ZC-8 can be used to adjust volume. Select the desired ZC type, and make sure it has the correct ID number. Set the maximum and minimum values for this zone controller. As a default, all volume zone controllers can provide up to +20dB gain boost and can cut to -Inf to mute.

Edit - Source Selection - A ZC-3, ZC-4, ZC-8, or ZC-9 can be used to provide source selection. Select the desired ZC type and make sure it has the correct ID number. For a ZC-3, ZC-8, or ZC-9 for each switch position, select the corresponding source. For a ZC-4, select the switch position 0-15 and choose the corresponding input source (see ZC-4 switch positions within the Appendix).

Edit - Page Routing - For a ZC-3, only four zones or groups of zones can be switched between. A ZC-4 can switch between 16 zones or groups of zones. Like a ZC-3, the ZC-7 only has four positions, so it will only support up to four zones or groups of zones, but it does have momentary switches that can be used in a push-to-call fashion, where each switch must be pushed and held to route the page to that zone or group of zones. Once you have performed all your zone controller configurations, click **NEXT** to move to the Routing Configuration.

3.3.4 Source Association

The Source Association page allows selection of the main Source, the Priority override source, the Page source, and the output level for each of the output zones. The Source ZC page appears as follows:

Input	Control		Control
Lobby MIC	None	Jukebox L	None
Phone Page	None	Jukebox R	None
CD L	None	TV L	None
CD R	None	TV R	None
Satellite L	None	DVD L	None
Satellite R	None	DVD R	None

Buttons: Cancel, < Back, Next >, Finish

3.3.5 Routing and Zone ZC Association

The Routing configuration Page allows selection of the main Source, the Priority override source, the Page source, and the output level for each of the output zones. If Zone Controllers are used for either source selection or level control, these should be selected in the Source or Level pulldown menu. If zone controllers are being used for Page Steering select None in the Page menu for those outputs unless a microphone is always paging to that zone in addition to the page steering.

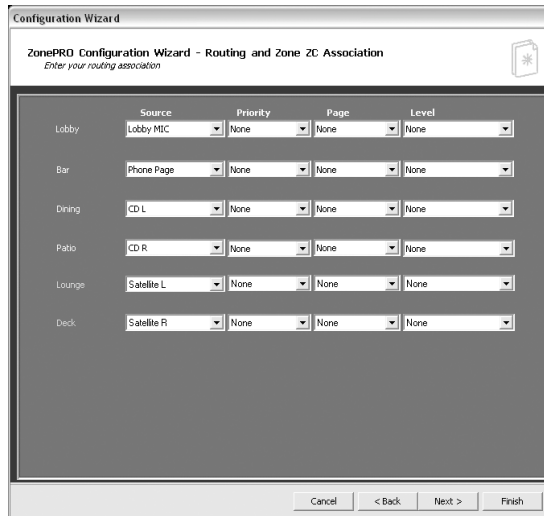

3.3.6 Front Panel Configuration

The Front Panel Setup Page allows selection of which controls will be available to the end-user of the ZonePRO unit. If Zone Controllers are being used for page steering, source, or volume control of an output zone these parameters will not be available from the front panel.

Once all the Wizard pages have been completed the configuration is ready to be loaded, this is accomplished by selecting finish. You will now be returned to the normal editing mode of the ZonePRO GUI.

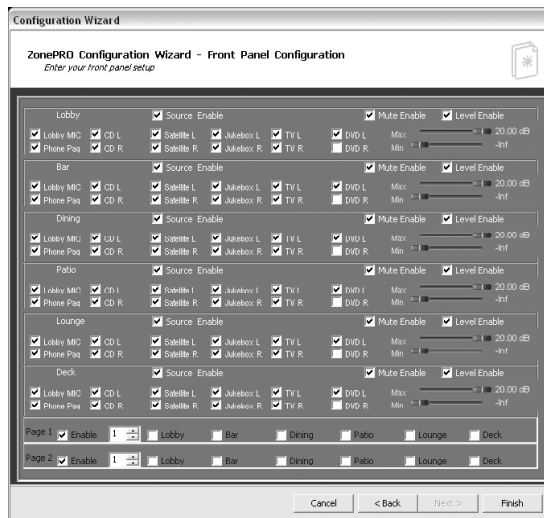

3.4 - Parameter Editing

All parameters can be edited by double clicking on the module. All the individual parameters are discussed, and can be seen in Section 4.

3.5 - Storing Scenes

After editing parameters the scene needs to be stored. You can store the scene by using the Scene Store button at the base of the device view, or use the Scene Wizard Menu also found in the device view.

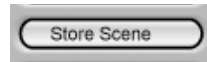

3.6 - Scene Wizard

The Scene Wizard function is used to change ZC associations, or Zone Routing for different scenes. From the Program Screen view Select the **Wizard** pull down from the menu bar and then select the option labeled **Scene Wizard**. Once selected, a window will appear as follows:

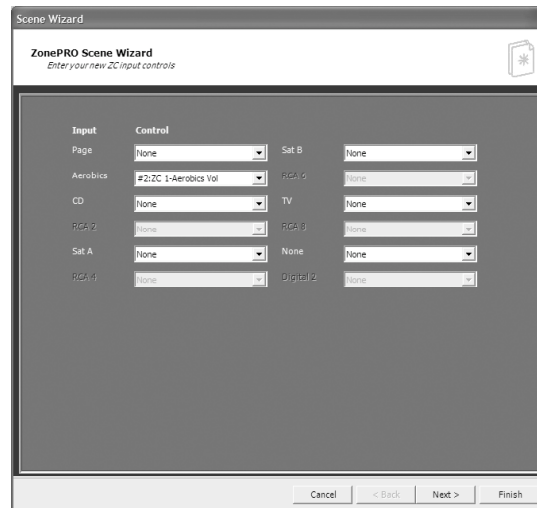

Once your changes have been made for page 1, press the **NEXT** button and page 2 will appear as follows:

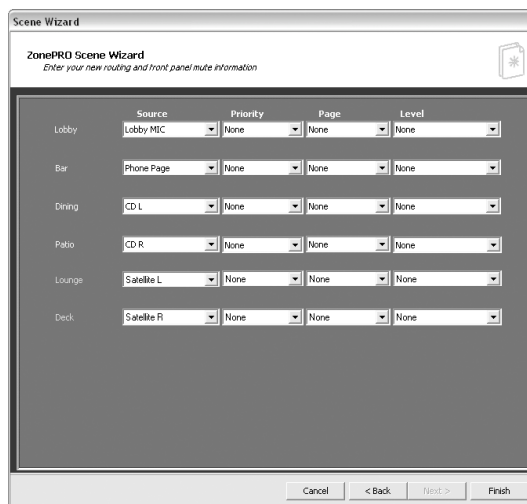

Once your changes have been for the scene wizard, press the **FINISH** button to exit.

3.7 - Schedule Wizard

The Schedule Wizard provides for pre-determined scene changes corresponding to the time of day and/or day of week. For example installations such as restaurants often require volume increases during peak hours of operation. This sub-section will walk you through setting up the Schedule Wizard.

From the Unit view of the setup, Select the **Wizard** pull down from the menu bar and then select the option labeled **Schedule Wizard**. Once selected, a window will appear as follows:

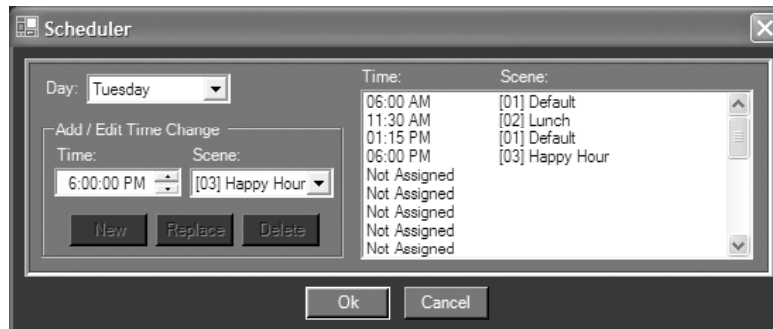

At this point you can create a schedule for each day of the week, by recalling scenes at any time with up to 1 minute resolution. Up to 24 scenes can be recalled per day. Once all changes have been made, select Ok or Cancel and the window will be closed.

3.8 - File Save

After editing and storing the scene or scenes you can store this file to your computer by selecting **File Save** from the Device View menu.

3.9 - Hardware Navigation

Many functions of the ZonePRO 1260 can be accessed and performed from the front panel of the unit. The following information will cover several areas of operation of the 1260.

Changes to the output zones can be made by pressing the buttons associated with them. Once an output button is pressed the available parameters are located on the front panel display. To edit any of them simply press button 1, 2, or 3 and edit that parameter. The page routing can also be edited in a similar fashion; press the button associated with that page microphone and select the desired routing.

**DETAILED
PARAMETERS**

The following section will provide you with a module block representation for each effect, as well as descriptions and explanations of all parameters within the ZonePRO.

4.1 - Input

The signal routing begins at the INPUT block of the ZonePRO™.

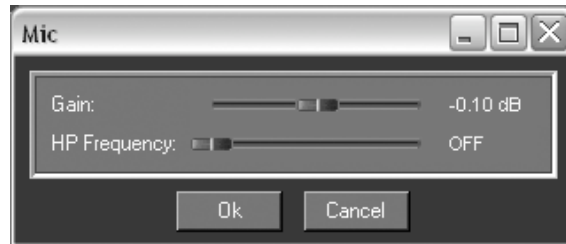

Gain Level -Inf to 20dB

Adjusts the input level.

HP Frequency Off, 14.96Hz to 118.85Hz (Mic Inputs and RCA S1-S2)

Adjusts the input High Pass cutoff frequency on the mic/line inputs.

4.2 - Parametric EQ

The ZonePRO units offer both Pre and Post-crossover parametric sections on each input, and may be configured as a single or linkable 2-band or 4-Band PEQ (Mic inputs and RCA S1 and S2).

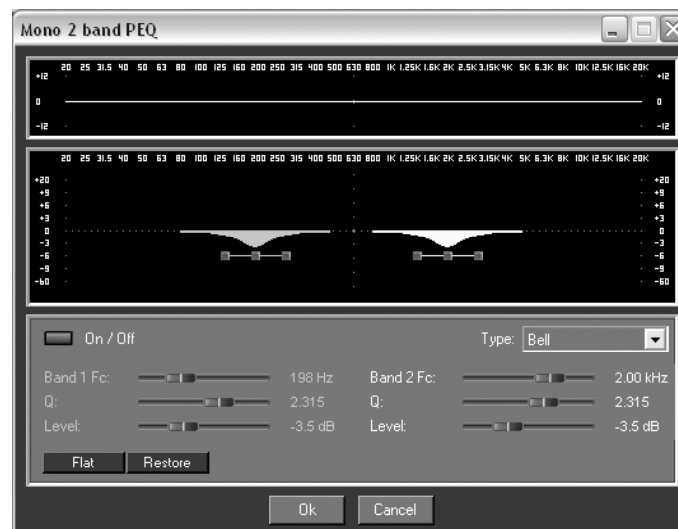

EQ On/Off

Turns the PEQ on and off.

Type Low Shelf, HighShelf, Low/High Shelf and Bell

The Type selector allows you to select either a Low, High, Low/High shelf or Bell EQ curve.

Flat /Restore

These buttons either flatten (Flat) or restore (Restore) all bands to their original settings.

Band (1-4) Frequency 20Hz to 20kHz (Low Shelf)

Selects the frequency of the EQ.

Q (1-4) 0.105 to 16.0

Selects the Q or the Bell parametric EQ.

Slope (Type: High and/or Low Shelf Selected) 3-12dB/Octave

Sets the slope of the High and/or low shelf parametric EQ.

Level (1-4) -12 to 12 dB

Sets the amount of boost or cut of the selected parametric EQ.

4.3 - AFS (Insert Module)

The ZonePRO™ offers the exclusive patent pending AFS (Advanced Feedback Suppression) feedback elimination module. Feedback is caused when a microphonic signal such as a guitar pickup or microphone is reproduced by an amplification and is repeatedly picked up in phase. The AFS module of the ZonePRO™ allows the user to optimize the elimination of feedback. With the AFS algorithm active the ZonePRO removes only the feedback frequencies without affecting the remaining audio spectrum.

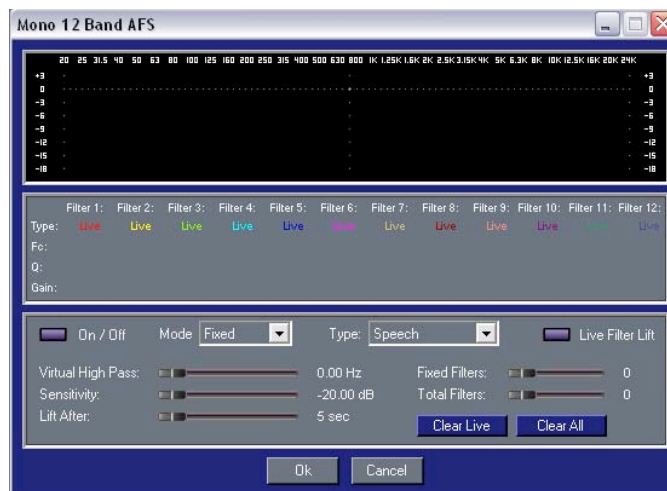
**AFS On/Off**

Turns the AFS module on and off. If AFS is Off, the filters are bypassed, and the algorithm is halted (the filters are not updated). If AFS is On, the filters are active, and they are updated according to the current selected mode (Fixed or Live).

Clear Live and ClearAll

These buttons (when selected) clear the filters. If Clear Live is selected, only the live filters are reset. If Clear All is selected, then all of the filters are reset.

Mode - Live or Fixed

When the mode is Fixed, the algorithm updates only the fixed filters. When the mode is Live, the algorithm updates only the live filters. In FIXED mode, the filters are stored with the program at that frequency until cleared by the user. Fixed mode is used during setup to set filters at frequencies that are most likely to feedback. In LIVE mode, the live filters automatically detect and remove feedback during the performance. When all of the live filters have been used, they begin to round robin. Essentially this means that the first filter set is moved where a new feedback is detected and notched out. This mode is useful because feedback frequencies may change as the microphone is moved, and/or as the characteristics of the venue change. Note- Only the fixed filter settings will be stored with the program.

Type - Speech, Low Music, Medium Music and High Music

Type allows the AFS algorithm to be customized for the application. The Values correspond to different Q and sensitivity settings. These types pertain to the Q, sensitivity, and algorithm type. Values are; Speech (Bandwidth = 1/5 octave and Q=7.25) Music Low (Bandwidth = 1/10 octave and Q=14.5) Music Medium (Bandwidth = 1/20 octave and Q=29) Music High (Bandwidth = 1/80 octave and Q=116). Note: To guarantee that feedback is suppressed at lower frequencies, the AFS may place wider notch filters at these lower frequencies (below 700 Hz).

Total Number of Filters 1-12

This parameter selects the number of filters being used

Number Fixed - 0-12

This parameter sets the number of Fixed AFS filters. This also sets the number of Live filters as the Total number of filters - number of Fixed Filters = number of Live Filters.

Live Filter Lift (On/Off)

This parameter turns the Live Filter Lift on and off.

Lift After - 5 sec to 60 min

This parameter allows the user to setup the box so that the Live filters will automatically be removed after a set time (as indicated by the "Lift After" parameter). It ranges from 5 seconds to 60 minutes. This feature is useful if the microphone being used is moved or the characteristics of the venue change over time. This feature removes unnecessary filters from the spectrum to increase sonic quality.

Detector Highpass Off, 11.7 - 410.1Hz

This parameter sets a highpass filter in the path of the AFS detector. There may be occasions where the AFS algorithm is removing too much low end because it is being triggered by Synthesizer or Bass notes that are not really feedback. This parameter provides a mechanism to make the AFS algorithm less sensitive to low frequency thereby setting fewer filters in the bass region.

Sensitivity -20-+20dB

The AFS algorithm is very effective when the audio has a nominal level of 0 dBu, however if the audio is too low in level the AFS algorithm may not catch feedback as quickly as possible. By increasing or decreasing the sensitivity you can adjust for audio that is either too loud or too soft and help the AFS function properly.

4.4 - AGC (Insert and DYN Module)

Mono

The AGC is used to keep the average level of a signal constant. This is done by selecting a desired Target output level and Window. The AGC keeps the signal within the Window about the selected Target by slowly adjusting the gain. The maximum gain that can be applied to the signal is selected by the Gain parameter. When the input signal falls below the Threshold the AGC stops adding gain and returns to unity. This prevents the AGC from adding gain when there is no signal present and raising the system noise floor. High level peak signals are reduced by a fast limiter to prevent distortion by clipping. The AGC Threshold meters show what region of the AGC the input signal is in. The T (yellow) indicates the signal is within the Window. A + (red) indicates the signal is above the target window. A – (green) indicates the AGC is adding Gain and is at or below the window. When the Threshold meter is off the signal is below the Threshold. The AGC module also includes a dedicated Limiter.

AGC On/Off

Turns the AGC module On and Off.

Target -20 to 20 dB

The Target parameter defines where you would like the average level of the AGC output to be. If the average level of the signal rises above the Target the gain will be reduced. For signals with an average level below the Target the gain will be increased.

Gain 1 to 20dB

This adjusts the maximum amount of gain that can be added by the AGC.

Window 1 to 10dB

This adjusts the amount of variation in the output

Low Threshold -60 to -30dB

The Low Threshold sets a lower limit to the AGC. This prevents the AGC from adding gain to low level signals or noise.

Attack 0.20 to 5 Seconds

This adjusts how fast the AGC will increase gain.

Release 30.0 to 1 dB/Second

This adjusts how fast the AGC will reduce gain.

AGC Limiter Threshold -40 to +20dBu

The AGC is designed to add or remove gain slowly to maintain an average signal level. Because of its slow nature a fast Limiter has been added to protect speakers from sudden transients. The Limiter threshold can be set from the top of the AGC Window up to +20dBu.

AGC Limiter Attack .01 to 200 m Sec

This is the speed at which the limiter starts to compress the signal once it has crossed the threshold.

AGC Limiter Release 360 to 5 dB / Sec

Just like the release time on the compressor, the limiter's release time controls how fast the limiter releases from gain reduction after the signal drops below the threshold.

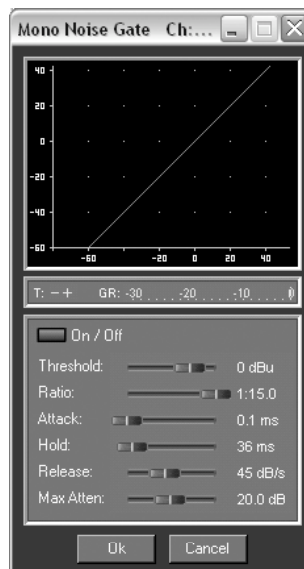
**4.5 - Noise Gate (Insert Module)****Gate On/Off**

Turns the Gate on and off.

Threshold -50 to 20 dBu

The threshold is the level at which the gate opens. Anything above the threshold passes, while signal that is lower than the threshold is attenuated. Beware, setting the threshold to high can cut off the tail end of signals as they fade out (the sustain of a guitar note, a held piano chord, a reverb tail, etc.).

Ratio 1:1.0 to 1:15

This is where you decide how much downward expansion you want. This ratio works opposite from that of the compressor or limiter. If a ratio of 1:4 is selected, a signal that is 1dB below the threshold will be reduced in gain so that it becomes 4dB below the threshold.

Attack 0.1 to 200 m Sec

As the signal reaches the threshold area, the Attack control sets the speed at which the gate opens. Use very fast attack times to catch the fronts of transient signals.

Hold 0 to 500 m Sec

The Hold control sets the amount of time the gate is held open after the signal passes below the threshold point.

Release 360 to 5 dB

Release sets the speed at which the gate “closes” or attenuates when the end of the Hold time is reached.

Max Attenuation 0 to Inf. dB

This sets the maximum amount of attenuation for the gate.

4.6 - Compressor (Insert and DYN Module)



The ZonePRO™ also offers a dedicated compression module. The Compressor is the perfect tool for tightening uneven signal sources such as vocals and guitars. The parameters for the Compressor are as follows.

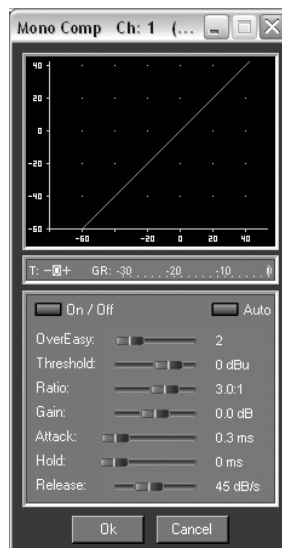

Compressor On/Off

Turns the Compressor module on and off.

OverEasy Off to 10

OverEasy is a soft-knee smoothing function that occurs about the compression threshold. OverEasy off is considered hard knee; the higher the OverEasy the greater the smoothing.

Threshold -40 to +20dBu

Threshold is the signal level at which the unit starts to compress the signal. If the level is set to -10 dBu, than any signal larger than -10 dBu is compressed while any signal that has a level that is lower than -10dBu is left at the same signal level. For most signals the most natural compression is achieved when most of the signal content remains just below the threshold and only the peaks cross the threshold.

Ratio 1.0 to Inf:1

Ratio is the amount the unit reduces the signal level of the sound that is above the threshold. A 2:1 ratio means that if the incoming signal is 2dB over the threshold the unit will compress the signal, and outputs a signal that only goes 1dB over the threshold. For light compression choose a lower ratio, while a heavy compression requires a higher ratio. A setting of Inf:1 makes the compressor act as a limiter.

Gain -20 to +20 dB

This parameter is used to compensate for the gain lost during compression. By using heavy compression on a signal and then boosting the signal with the output gain, the user can create a signal that sounds much louder than it actually is.

Auto On/Off

When Auto Mode is on, the ZonePRO™ automatically sets the Attack, Hold, and Release times for the signal. The auto mode constantly adjusts these parameters in real time for optimum performance from the unit. You will find that for most applications, not only is using the auto mode faster and easier but by letting the unit constantly tweak these parameters for you will result in a better end result.

Attack 0.1 m Sec to 200 m Sec

Attack is how fast the compressor starts to compress the signal after it passes the threshold. Fast attack is useful when dealing with lots of fast transients. The attack control is not active when in auto mode.

Hold 0 to 500 m Sec

Hold is the time the ZonePRO remains in compression after the signal has dropped below the threshold. A longer hold time is useful in smoothing out the sound when compressing several fast peaks that are fairly close together in time. The hold control is not active while in auto mode.

Release 360 dB / Sec to 5 dB / Sec

Release is how fast the ZonePRO comes out of compression. The release is in dB per second. For example, if release is set to 5 dB /sec, and the signal is at 10dB of gain reduction, the release time is 2 seconds. Having a release time that is either too fast or too slow for the signal can result in audible artifacts called pumping or breathing. This can cause volume drops in your signal that may not be desired. The release control is not active while in auto mode.

4.7 - De-Esser (Insert Module)

The ZonePRO™ offers a de-Esser module. This De-esser effect is ideal for removing unwanted vocal sibilance. These parameters are user adjustable on all programs and are as follows:

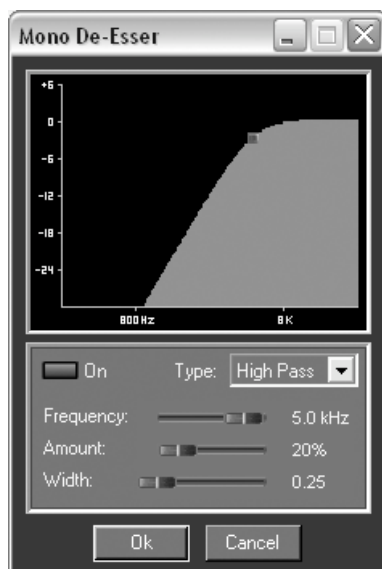
**De-Esser On/Off**

Turns the De-Esser on or off.

Freq 800 Hz to 8.00 kHz

This is the center frequency the De-Esser uses when in Band Pass mode or the corner frequency used when in High Pass mode.

Amount 0 to 100%

This controls the amount of De-Essing. The amount control is very much like a combination threshold / ratio control. A higher amount applies more De-Essing to the signal.

Type HP or BP

Selects the type of filter used by the De-Esser.

Width

Sets the Q of the Band Pass Filter.

4.8 - Notch Filters (Insert Module)

The notch filter is the perfect tool for dropping out undesirable frequencies that may appear in the input signal.

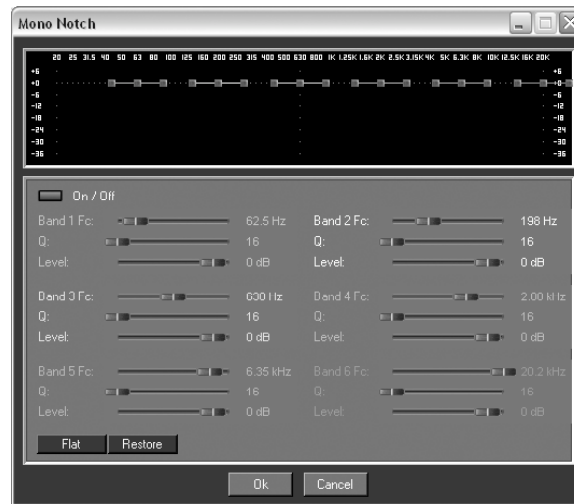

Notch On/Off

Turns the notch filters on and off.

Frequency (1 to 6) 20 to 20K

Selects the desired notch filter frequency of the selected notch filter.

Q 16 to 128

Selects the Q of the selected notch filter.

Level -36 to 6 dB

Sets the level of the selected notch filter. Set to +6dB to help find unwanted feedback, then set to -3dB to -36dB to remove.

4.9 - Router/Mixer

The Router or Mixer (selected in setup) module is the heart of the ZonePRO device and allows for a primary source, a priority override sources and a paging source, where the paging source has the highest priority. Both priority override and page have duckers that allow them to duck the previous sources.

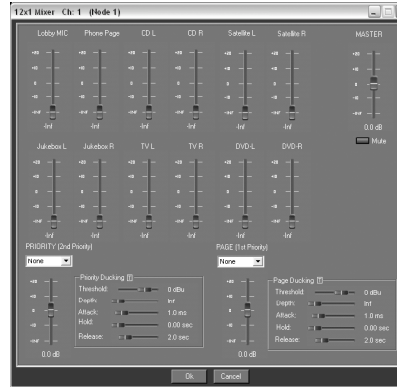
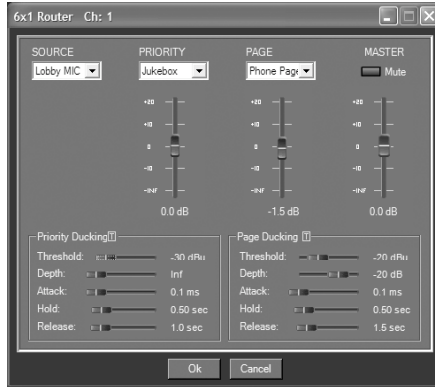

Source Select

This parameter allows the user to select the input source for the zone.

Priority Select

This parameter allows the user to select which input will override the primary source signal.

Priority Level -Inf to 20dB

Adjusts the output level of the selected Priority input signal.

Page Select

This parameter allows the user to select which Paging input will override the source signal.

Page Level -Inf to 20dB

Adjusts the output level of the selected Paging input signal.

Master Level -Inf to 20dB

This parameter adjusts the output level of of the Zone.

Master mute

When selected, the the signal will be muted for the Zone.

Both the Router and Mixer provide Ducking capability along with selection of a priority and paging source. The Priority Ducker attenuates the primary source and adds the Priority source. The Priority source is also gated using the same timing as the Priority Ducker. When the Priority source crosses the Priority

Ducker Threshold the Ducker attenuates the Primary source by the Depth amount. At the same time the Priority Gate opens to allow the Priority source to be summed over the primary source. The Gate depth is -INF when closed to prevent adding noise to the primary source.

The Page Ducker attenuates both the primary source and the Priority source if present. A Page source Gate can be added using the Mic/Line Insert 1 or 2.

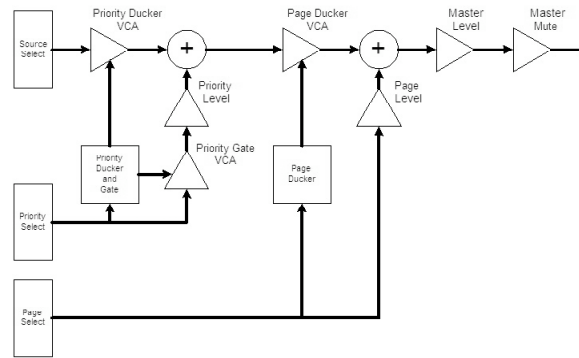

Threshold -40 to +20dBu

Threshold is the level from the priority or page source at which the Ducker will attenuate the Router source.

Depth Inf to 0dB

This parameter sets the amount of Ducker attenuation.

Attack 0.1 m Sec to 200 m Sec

Attack is how quickly the signal is attenuated by the Ducker

Hold 0.1 to 20.2 m Sec

Hold time is the length of time before the Ducker releases.

Release 0.0 to 10.0 dB/Sec

Release is how quickly the attenuated signal returns to its nominal level.

Fader (Mixer Module Selected)

The fader parameter allows you to control the output volume of each mixer channel

Auto

4.10 - Auto Warmth®

The ZonePRO™ 1260 and 1260 offer the AutoWarmth® module on each output. AutoWarmth® is a patent pending process that compensates for naturally occurring bass frequency loss for low level signals. The Fletcher-Munson Equal Loudness curves show that the perception of low frequency signals decreases quickly with decreasing loudness. AutoWarmth® gradually boosts the low end in response to the overall loudness of the signal. The result is warm and balanced signal at low levels.

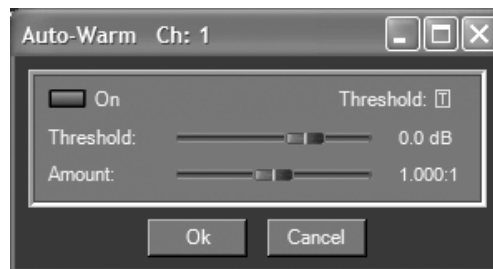

Auto Warmth On/Off

This parameter is used to turn the Autowarmth module on and off.

Threshold -40 to +20dBu

The threshold sets the level where AutoWarmth® begins to work. Signals below the threshold are processed to increase the Bass response in proportion to the overall volume of the signal. Above the threshold there is no processing. The Threshold meter will light Green when the threshold has been crossed and AutoWarmth is active. To set the threshold, turn AutoWarmth® off and adjust the Master gain in the router to the desired listening level. Turn AutoWarmth® on and adjust the threshold until the threshold meter just turns off. Now as the volume decreases below the desired level the bass will gradually increase. Be careful when using AutoWarmth® followed by an AGC. The AGC can add gain when below the AutoWarmth® threshold resulting in overcompensated Bass.

Amount 0.25:1 to 4.00:1

The amount controls how much Bass is added. A setting of 1.00:1 compensates the signal as described by the Fletcher-Munson Equal Loudness curves. Higher settings (greater than 1.00) causes more bass. Lower setting result is less bass compensation.

4.11 - Bandpass Filter/Crossover (BPF)



Highpass Out to 20kHz

Adjusts the lowest frequency that the output will achieve.

Lowpass Out to 20Hz

Adjusts the highest frequency that the output will achieve.

Gain -Inf to 20dB

Sets the gain of the Crossover output.

Low Pass and High Pass Slope - Butterworth (BW 6,12,18 and 24), Bessel (BS 6,12,18 and 24) and Linkwitz-Riley (LR 12 and 24)

Selects the desired crossover slope type.



4.12 - Output Dynamics

The ZonePRO™ units offer a dedicated output dynamics module which includes Compression, Limiting and Auto Gain Control. The Output Dynamics are located on each output channel and have been strategically placed for speaker and amplifier protection. Note: Compression parameters are explained in sub section 4.5, and AGC parameters are explained in sub section 4.3.

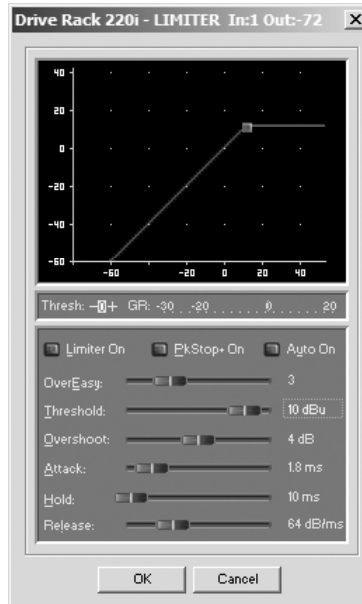

Limiter On/Off

Turns the Limiter module on and off.

OverEasy (O) Off to 10

OverEasy is a soft-knee smoothing function that occurs about the limiting threshold. OverEasy off is considered hard knee; the higher the OverEasy, the greater the smoothing.

Threshold -40 to +20dBu

Threshold is the signal level at which the unit starts to limit the signal. If the level is set to -10 dBu, any signal larger than -10 dBu is limited while any signal that has a level that is lower than -10dBu is left at the same signal level. Light limiting is where only the loudest parts of the signal go over the threshold. Very heavy limiting can be achieved by setting the threshold low enough that almost the entire signal content is over the threshold. For most signals, the most natural compression is achieved when most of the signal content remains just below the threshold and only the peaks cross the threshold.

Auto On/Off

When auto is turned on the ZonePRO™ will continuously set the attack / hold / release controls itself.

Attack .01 to 200 m Sec (per band or global)

This is the speed at which the limiter starts to limit the signal once it has crossed the threshold.

Hold 0 to 500 m Sec (per band or global)

Hold is the time the limiter stays in gain reduction after the signal level has dropped below threshold. Hold is useful when you want the limiter to function for a period of time after it has

been triggered. **Be careful not to set the hold time too long as it will not release in time.**

Release 360 to 5 dB / Sec (per band or global)

Just like the release time on the compressor, the limiter's release time controls how fast the limiter releases from gain reduction after the signal drops below the threshold. Set the release times longer for lower frequency bands and shorter for higher frequency bands.

PeakstopPlus® On/Off

The first stage of PeakStopPlus is the Instantaneous Transient Clamp™ which clamps the signal with a soft logarithmic clamp function. This logarithmic function ensures that the signal will not exceed the level set by the PeakStopPlus OVERSHOOT control by more than the overshoot amount, and that it will not introduce harsh artifacts. The second stage is a unique program limiter featuring Intelligent Predictive Limiting™. Its function is to monitor the input signal and intelligently predict the amount of gain reduction needed to keep the output signal below the ceiling set by the Instantaneous Transient Clamp™.

Overshoot 1-6

This parameter sets the amount of overshoot for the Instantaneous Transient Clamp™.

4.13 Delay



The parameters for the delay are as follows and are user adjustable:

Delay On/Off

Turns the delay module on and off.

Length

Sets the amount of delay time. Maximum delay time is 650ms.

Units Seconds, Feet or Meters

Selects the unit of measurement for the delay.

4.14 - Output

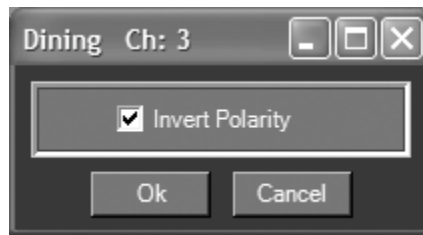

Polarity Normal or Invert

This section is used to select either the Positive or Negative polarity.

**APPLICATION
GUIDE**

5.1 - Restaurant Install

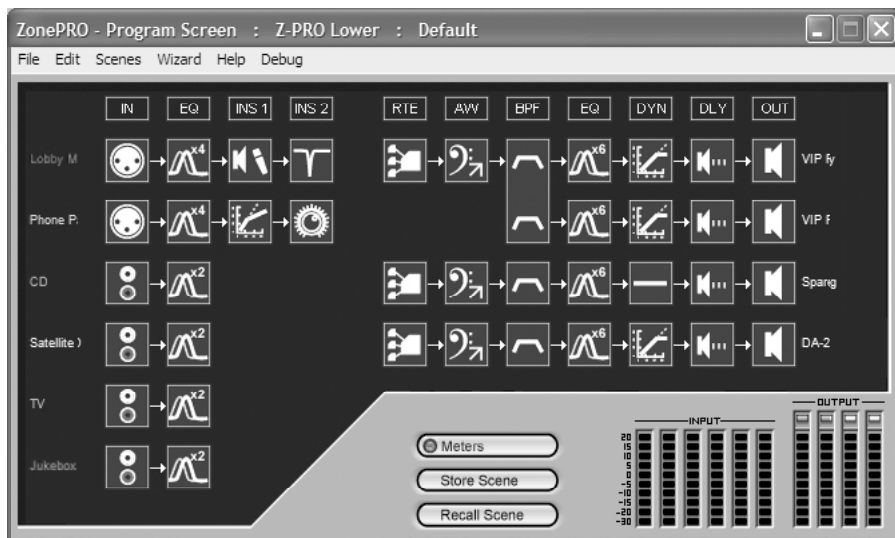
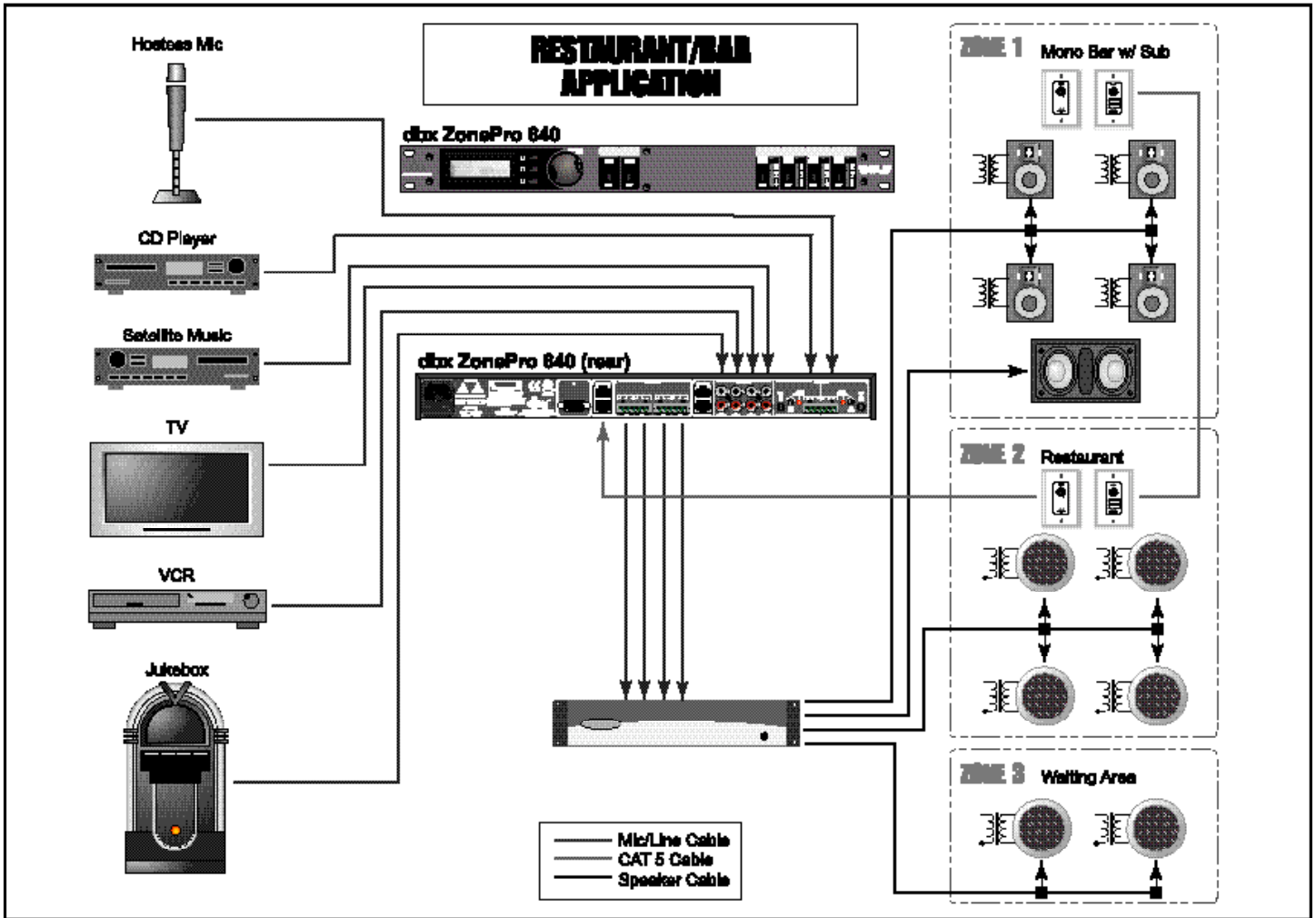

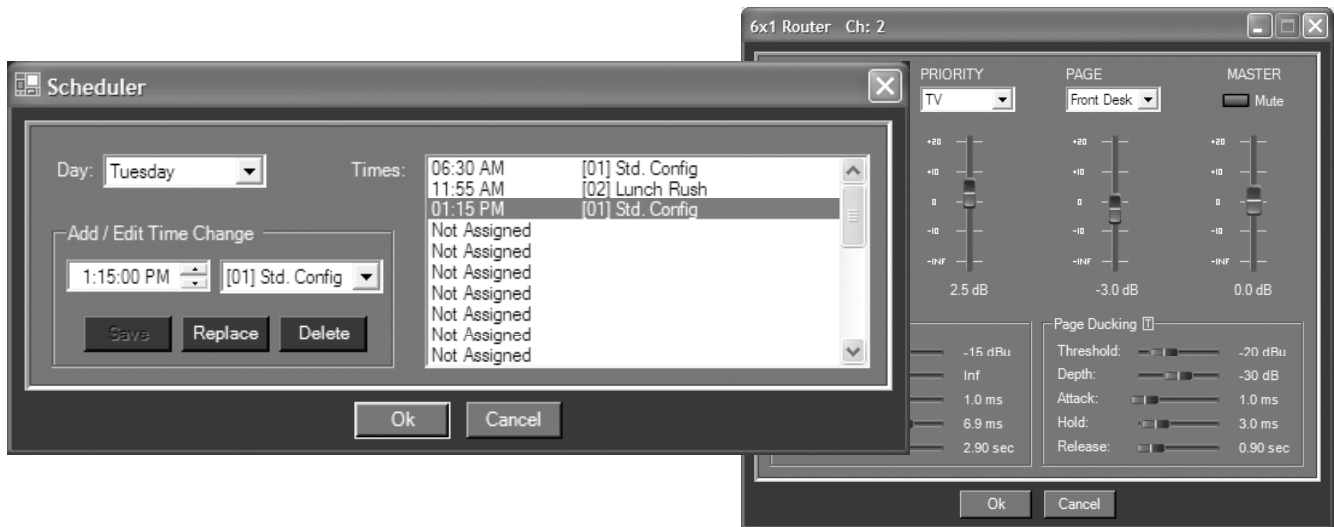

Notes - Restaurant/Bar Application

1. The ZonePRO 640 is located in the manager's office and provides source selection for the waiting area.
2. Both the restaurant and the bar area have ZC controllers. The bar is using them for source selection and volume control, the ZC-1 in the restaurant is used for volume control, and the ZC-3 is used for scene changes.
3. Paging is done from the hostess station and is pre-assigned to the bar, and the waiting area.
4. The Zone Controllers for the bar and restaurant are wired with CAT5 cable in series with the bar ZC-3 and ZC-1 as ID #2, and #3, and the restaurant ZC-3 and ZC-1 as ID #1 and #4.
5. Scenes have been created that accommodate changes in the venue such as a volume boost in the bar for happy hour as well as the regular volume boost in the restaurant for the lunch time rush and the dinner crowd.
6. The ZC-3 in the restaurant is used to change between scenes as needed.
7. The Schedule function has been used to load the Rest. Boost scene automatically at the beginning of the lunch and dinner periods.
8. EQ, Feedback Suppression and Compression are used on the hostess mic to help improve intelligibility and reduce unwanted feedback in the system.
9. Limiting is used in the bar area to provide system protection.
10. AutoWarmth® is engaged in the bar to maintain the bandwidth even when the level drops, while Auto Gain Control is being used in the restaurant and waiting areas to maintain the signal level.
11. EQ is used in all zones to make the system sound as good as possible.

5.2 - Health Club Install

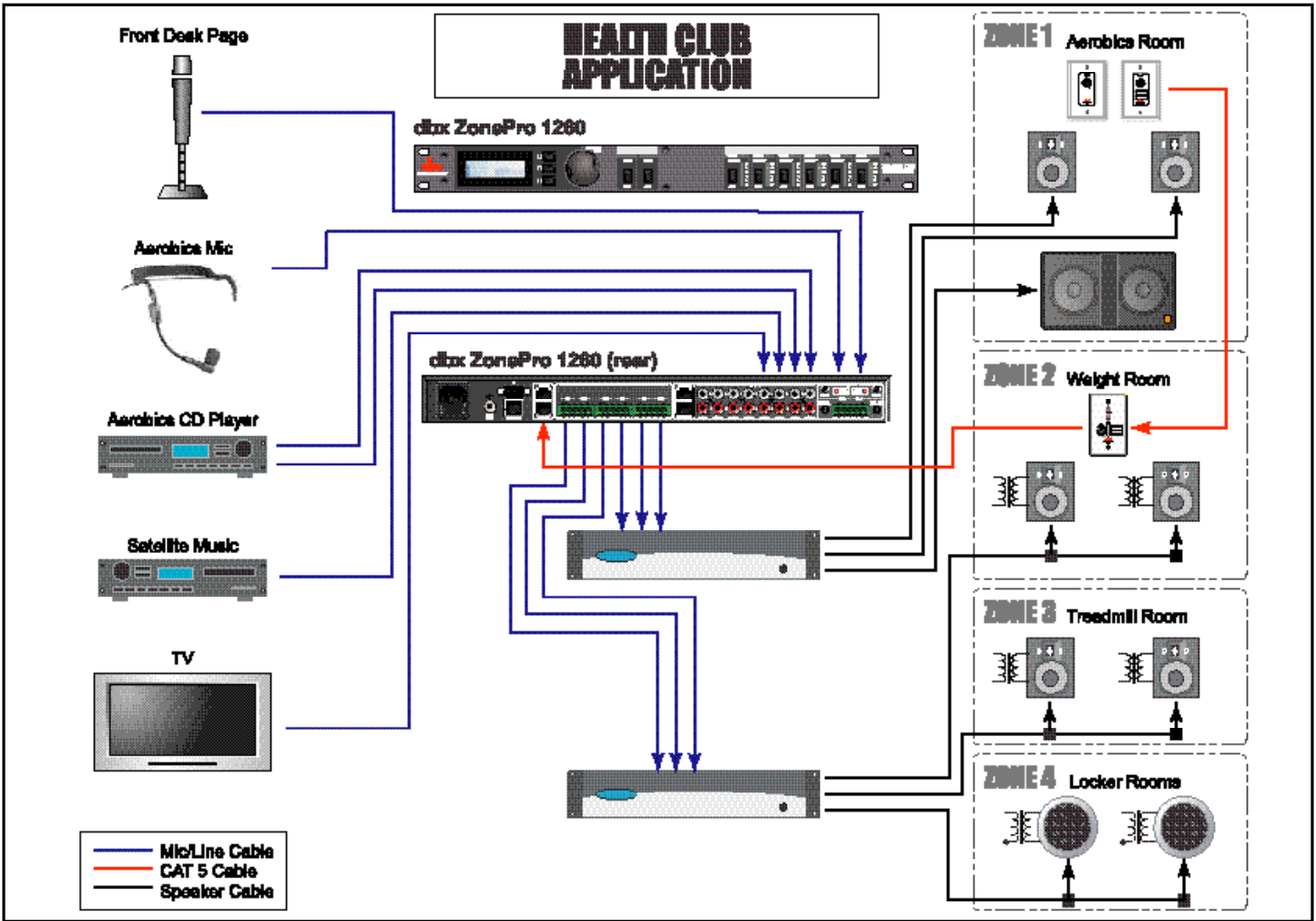

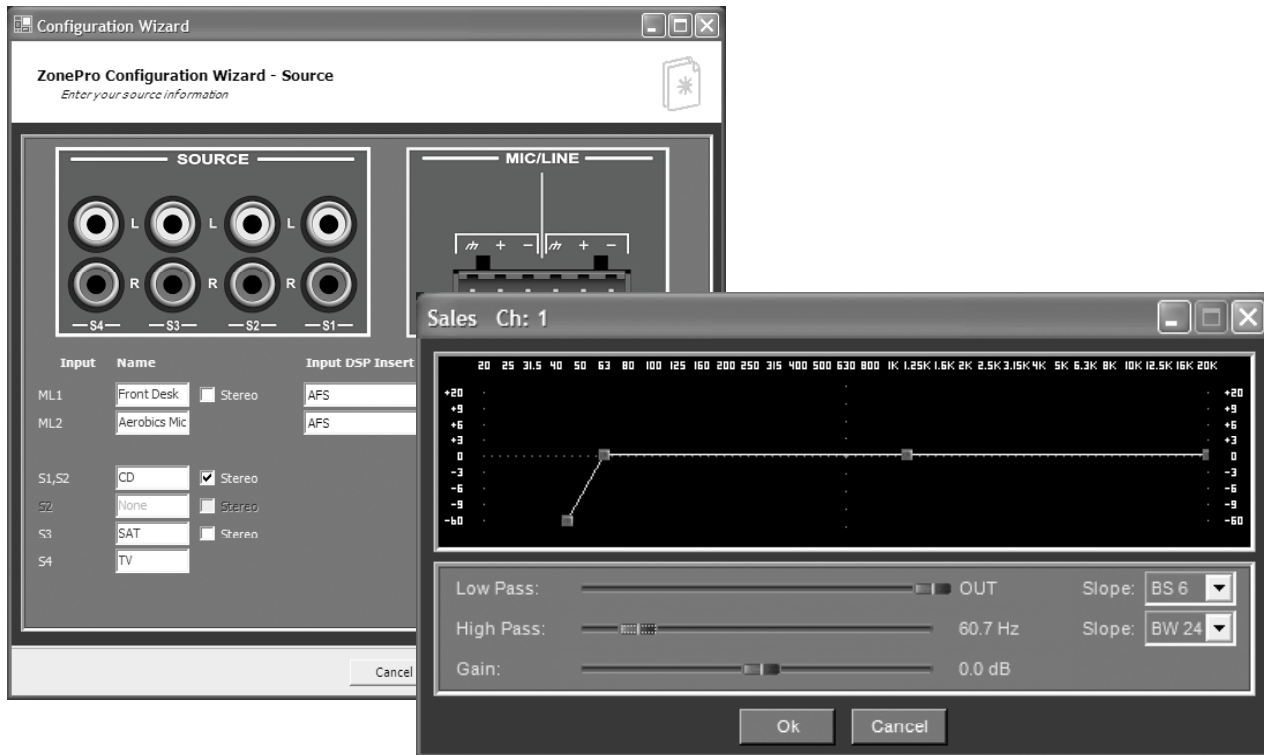

Notes - Health Club Application

1. The ZonePRO 1260 unit is located near the front desk area.
2. ZCs in the weight room and the aerobics room allow source selection and volume control.
3. The aerobics instructor's microphone is routed only to the aerobics area as the Priority source and is simply mixed in as the priority source rather than Ducking the primary source.
4. The Input Link Buss is used to send the inputs down to the second ZonePRO device.
5. The TV feed comes from the treadmill room and it is the priority source for that area overriding the primary source. Whenever the TV is on, its audio is routed to the treadmill room and it can also be selected in the weight room.
6. The locker rooms always have as their primary source the Satellite Music and receive paging from the front desk.
7. Since we do not need the Aerobics Mic to be routed to any of the zones other than the aerobics room and we are using the Input Link Buss to duplicate the inputs from the first ZonePRO device to the second, we could include another CD player and route it to the second mic/line input on the second ZonePRO device. The ZonePRO devices offer a "Local Page" facility on each of the mic/line inputs allowing selection between the sources coming in on the Buss and the local source. This would allow all the zones that are being fed by the second ZonePRO device to have an additional CD source to select from.

5.3 - Night Club Install

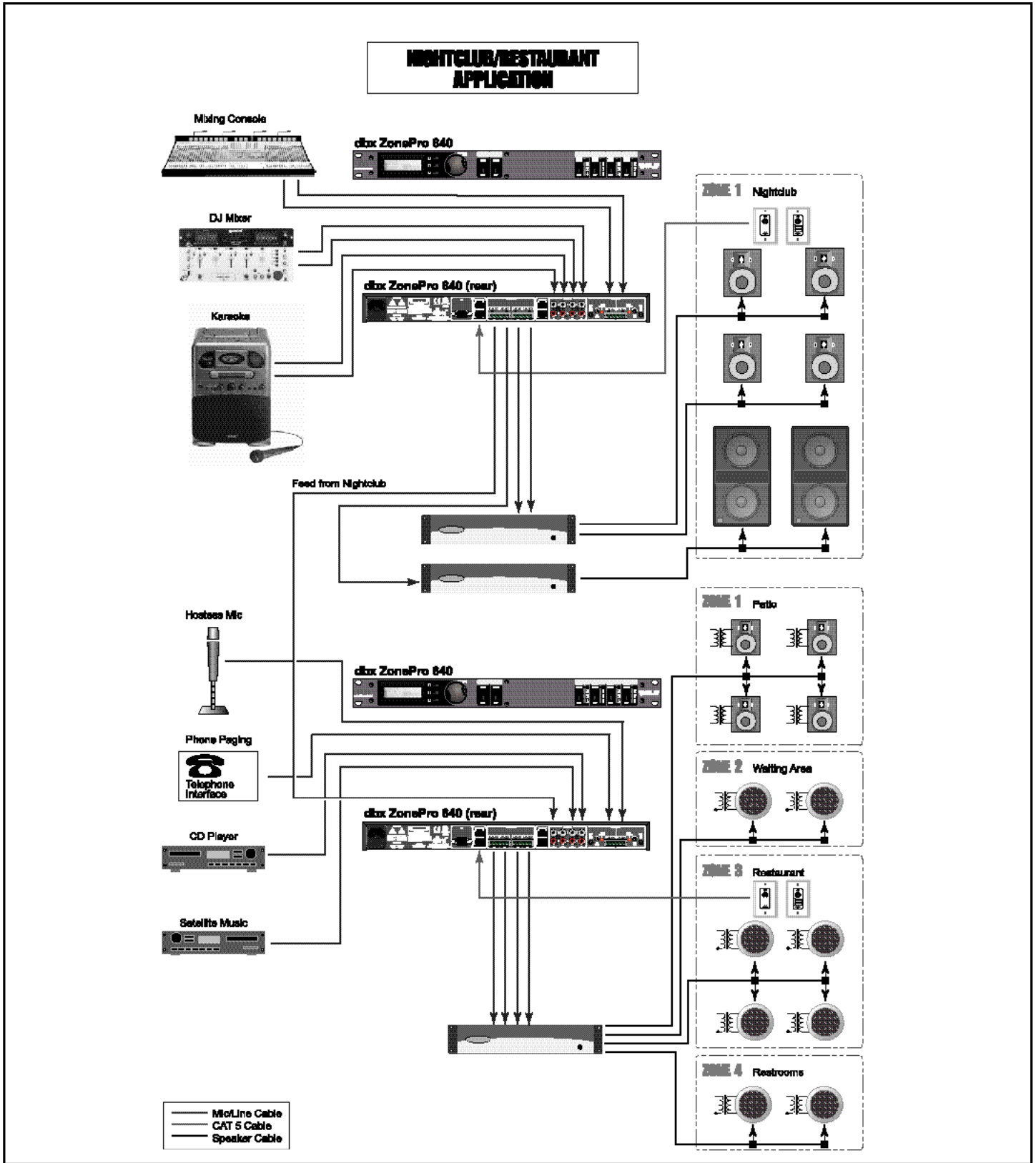

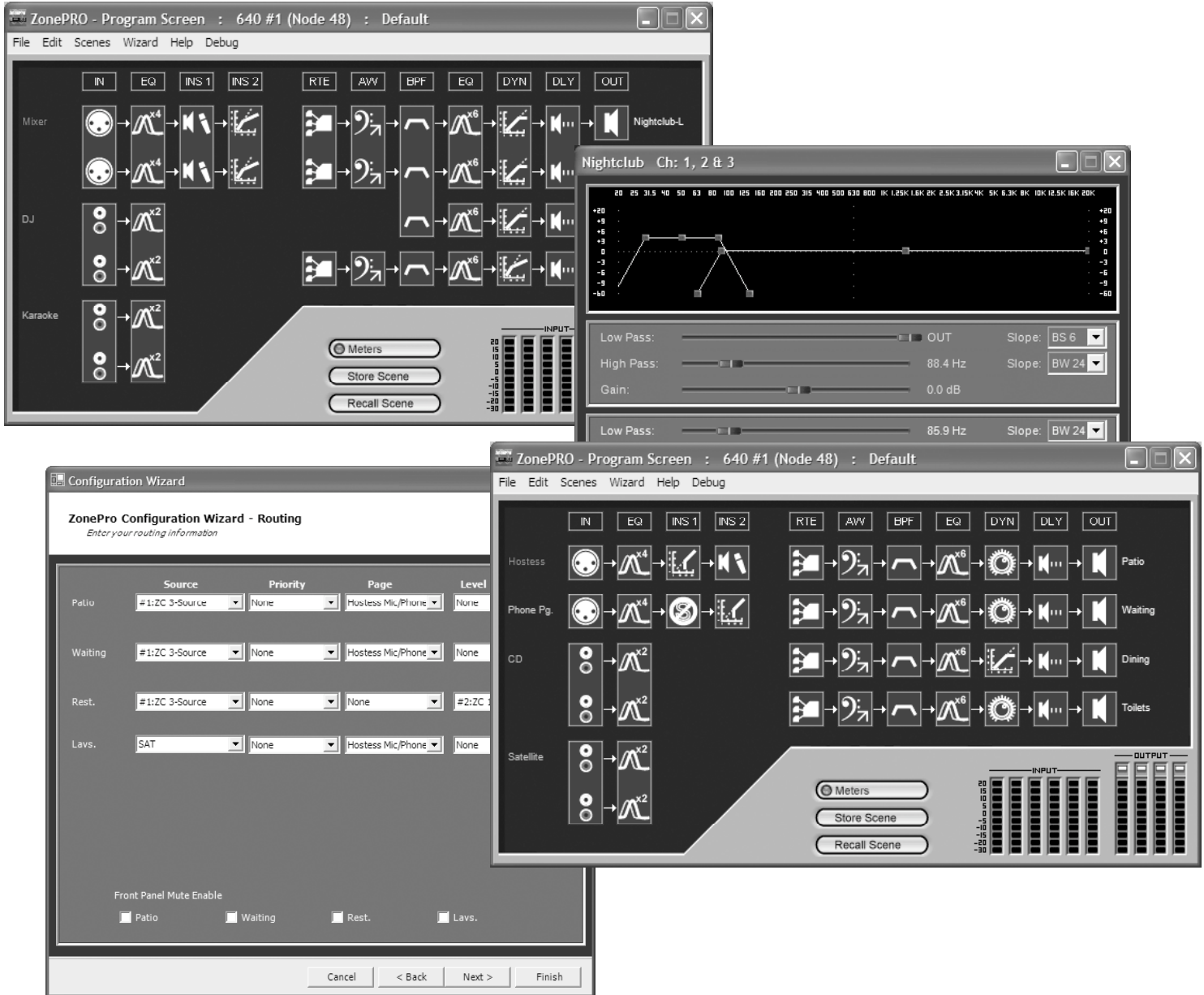

Notes - Nightclub Application

1. The ZonePRO 640 units are located in the manager's office.
2. The ZCs in the nightclub are situated near the bar and allow source selection and volume control.
3. The feed from the nightclub allows the restaurant to receive the signal from the nightclub allowing it to be sent to the entire restaurant.
4. Output Delay is used to delay the signal from the nightclub area so it arrives at the same time as the acoustic signal from the nightclub.
5. The zone controllers in the restaurant allow source selection and volume control of the restaurant area.

This page intentionally left blank

**APPLICATION
Notes**

6.1 - Using the Input Link Bus

The Input Link Buss allows the first six inputs from unit to be sent via a piece of CAT5 cable to the second, third or more units. Simply get a short piece of CAT5 cable cut to the appropriate length and place one end in the Link Output RJ-45 connector of the unit sending the signals and the other end in the Link Input RJ-45 connector of the unit receiving the signals. If there are signals that you do not want to send down you can either open those connections on the piece of CAT5 or you can use the internal jumpers on the two mic/line inputs to disable the link input for those signals (see Appendix A.4).

6.2 - Using the ZC as a Scene Selector

The ZC-3 and ZC-4 can be used as a scene selector. To do this they must be setup as such in the ZC Configuration page of the Configuration Wizard. If you select a ZC-3 or ZC-4 in ID#1 you can select a check box for Scene selection. The Edit button allows selection of the individual scenes that will be loaded for each switch position of the ZC-3 or ZC-4.

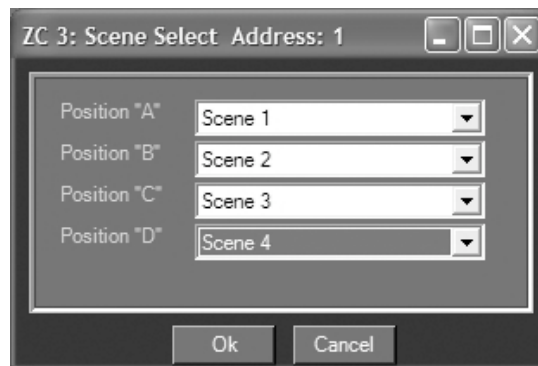

6.3 - Using the ZC Fire

The ZC-FIRE is a special case of Scene selection allowing either muting of the entire system or the recall of a specific Scene. To use a ZC-FIRE you must place it in the ID#2 position of the ZC Configuration page of the Configuration Wizard. You can then select the Edit button and choose whether you want the ZC-FIRE to be active High or Low, and select whether you want to either mute all outputs, or load a specific scene.

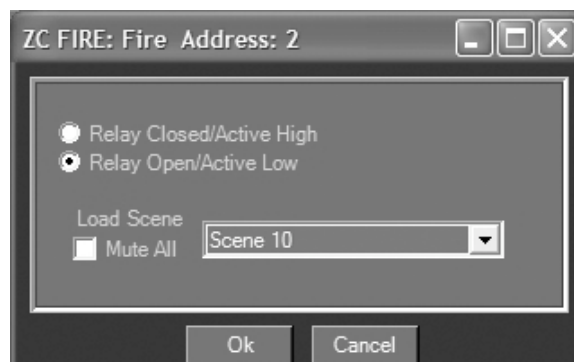

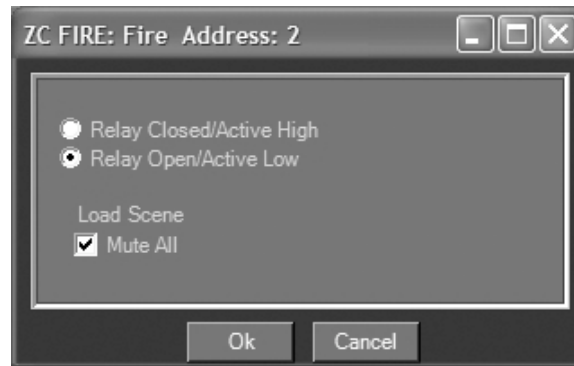

6.4 - Using the Locate Function

The Locate Function is useful when there are multiple units on the network and you want to verify which unit you are actually working with. To Locate the unit select Locate from either the Device Menu in the Venue View with a particular device highlighted, or you can select Locate from the Help Menu of the Device View. When selected, the Locate function will flash the LCD screen of the 1260 or the Network Traffic LED of the 1261.

6.5 - Using the Address/Network Wizard

From the ZonePRO designer Screen view of the setup, select the **Network** pull down from the menu bar and then select the option labeled **Properties**. Once selected, a window will appear as follows:

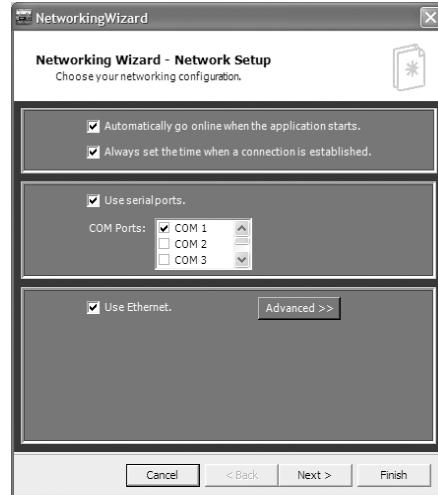

This page allows you to set networking preferences like startup behavior and methods of connection from the GUI to the ZonePRO units (Serial Port and/or Ethernet). This page also allows you to configure Proxies. Only add a proxy if you will be connecting to pre-configured 1260/1261 over a complex / remote network. For initial setup of a ZonePRO leave this field empty. Please refer to the appendix for more information on network setup and proxies. Once you have made your selection, click on the Next Page button and the display will appear as follows:

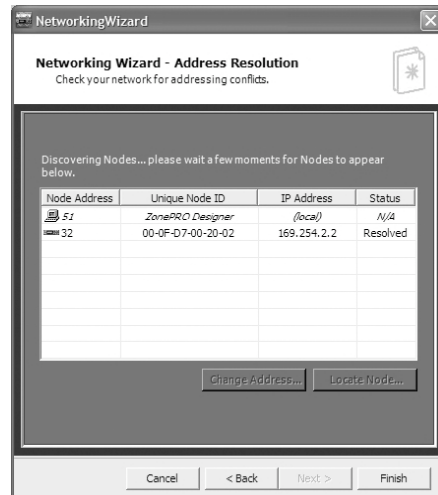

At this point, the ZonePRO designer is about to perform its Node discovery of any devices that are present on your network. Click on the Next Page button and the display will appear as follows

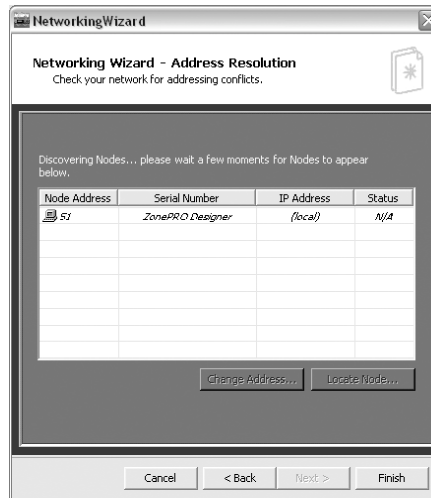

Now the ZonePRO designer will display the Address Resolution page. This page will inform you as to any addressing conflicts and allow you to fix them. This page displays a list of ZonePRO units that are on the main ZonePRO Designer device window as well as the ZonePRO units that are discoverable on the network. There are four columns of address information for the ZonePRO Designer software (the top line) and each of the ZonePRO devices. Every ZonePRO unit needs a unique Node Address that is used to identify the unit within the HQ Network of audio devices. Node Addresses can be any integer between 1 and 65534 except for 48 which is reserved. The next field is the Hardware Address. This is an identifier for the ZonePRO hardware it is a fix value and can not be changed. This value is also the MAC address for the Ethernet Hardware. Devices connected via Ethernet need to have a unique and correctly configured IP address. For more details on correct IP Network settings please read the appendix. To change either the Node address and/or the IP configuration of the device select the unit from the list and click the **Change Address...** button.

The Last column of in the Address Resolution window is Status. There are three different states that are shown here in the status box. The first is Offline. In this state the ZonePRO Designer software is aware of the ZonePRO unit and has an icon for it on the main page of the software but can not currently find it on the network. A device in the Detected state has been found on the network but not as one of the ZonePRO devices already known to the software. A devices status is Resolved when it has both been found on the network and in the ZonePRO Designer software.

The Locate Node... button can be a very useful tool help identify a ZonePRO on the network. This button pops up a window that allows you to start and stop the locate feature. Once started the ZonePRO 1260 will flash the back-light on the display so that you can know which device you are configuring. The ZonePRO 1261 will flash its power LED on the front panel. The slider on this window lets you set the amount of time that the ZonePRO will stay in the locate (flashing) mode. If the slider is set to "inf." it will flash until the stop button in the locate window is pressed or until the power is cycled on the ZonePRO. Once this function has been completed, click on the Finish Page button and the display will you to the ZonePRO designer page, where you can proceed to add/edit any units within your network.

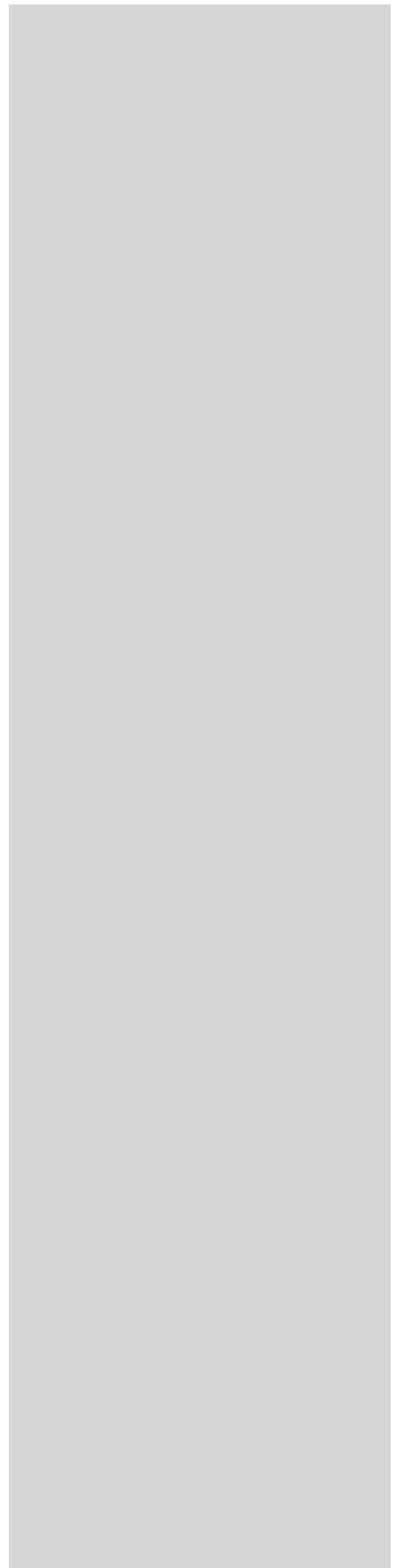

A.1 - Factory Reset/Flash Update

In the event that a reset is required, the ZonePRO offers you the option of performing a “Hard” or “Soft” Factory Reset.

The results of performing a “Soft” reset are:

- The currently loaded scene is reset to Scene 1.
- The state of the current loaded scene parameters is reset to what has been stored in flash for that scene (this invalidates the state of those parameters when the unit was last turned off).

The result of performing a “Hard” reset are:

A “Soft” reset is performed.

- The Node Address for the unit is reset to 32.
- The DHCP flag for the unit is reset to 0.
- The IP Address for the unit is reset to 169.254.2.2
- The IP Subnet Address for the unit is reset to 255.255.0.0
- The IP Gateway Address for the unit is reset to 0.0.0.0
- The “Fire” state of the unit is reset to UNARMED.
- The entire User Flash Memory is erased and initialized to contain the Factory Default Configuration and the Factory Default Scene 1.
- RTC schedule reset (nothing scheduled) and stored to User Flash Memory.

Factory “Soft” Reset From the Front Panel (1260 Only)

Press and Hold <3> button on power-up until the following message appears in the display:

```

(!: SOFT RESET?
<Yes <UTIL>
<No <PAGE1>

```

To activate a “Soft” Reset: Press the <UTIL> Button.

Pressing any button other than <UTIL> will abort the “Soft” Reset. The unit will reset normally.

Factory “Soft” Reset From ZonePRO Designer (1261 Only)

In the “Help” tab of the program dialog of ZonePRO Designer select 641/1261 Operation > Soft Reset. This sends a message to the 1261 to perform a “Soft” Reset and Restart itself. ZonePRO Designer will go offline when the 1261 is restarted.

Factory “Hard” Reset From the Front Panel (1260 Only)

Press and Hold <2> button on power-up until the following message appears in the display:

```

(!: HARD RESET?
“Yes <UTIL>”
“No <PAGE1>”

```

To activate a “Hard” Reset: Press the <UTIL> Button.

Pressing any button other than <UTIL> will abort the “Hard” Reset. The unit will reset normally.

Factory “Hard” Reset From ZonePRO Designer (1261 Only)

In the “Help” tab of the program dialog of ZonePRO Designer select 641/1261 Operation > Hard Reset. This sends a message to the 1261 to perform a “Hard” Reset and Restart itself. ZonePRO Designer will go offline when the 1261 is restarted.

Flash Update (1260 Only)

A 1260 firmware release will include a PC application that will download the new version to a unit connected via RS232. The receiving 1260 should be running. Follow the directions in the PC flasher application.

If, for some reason, you are not able to update your firmware successfully using this method, there is another “back-door” method. This method forces the 1260 into a special Flash Update Receive Mode:

Hold the <1> button while connecting power to the 1260. The following message will appear:

```

<WAITING FOR
<FLASH DOWNLOAD
blank
<2C000801

```

The unit now accepts a flash download from the PC flasher application.

Follow the instructions on the LCD when the flash completes.

Flash Update (1261 Only)

A 1261 firmware release will include a PC application that will download the new version to a unit connected via RS232. The receiving 1261 should be running. Follow the directions in the PC flasher application. If, for some reason, you are not able to update your firmware successfully using this method, there is another “backdoor” method. This method forces the 1261 into a special Flash Update Receive Mode: In the “Help” tab of the program dialog of ZonePRO Designer select 641/1261 Operation > Flash Start. Close ZonePRO Designer and open the PC flasher application. Follow the directions in the PC flasher application. Disconnect and then reconnect the power to the 1261 when the flash is complete.

A.2 - Specifications**Analog Inputs:**

Number of Inputs:	12 Total (2) Switchable mic or line, (8) RCA, and (1) S/PDIF
Connectors:	Euroblock (Line and Mic), RCA (Source) and RCA (S/PDIF)
Type:	Electronically balanced, RF filtered
Impedance (Euroblock):	> 50k Balanced, >25k Unbalanced, RF Filtered
Impedance (RCA):	>25k Unbalanced, RF Filtered
Max input line level:	+20dBu Mic/Line, +12dBu RCA
CMRR:	> 40dB, typically >55db @ 1kHz
Mic Pre gain:	30 to 60dB
Mic EIN:	> 118dB, 22Hz-22kHz, 150 Source Impedance
Mic Phantom Power:	15V

Analog Outputs:

Number of Outputs:	6
Connectors:	Euroblock
Type:	Electronically balanced, RF filtered
Impedance:	120 balanced, 60 unbalanced
Max Output Level:	+20dBu

A/D Performance:

Type:	dbx Type IV™ conversion system
Dynamic Range line:	>113 dB A-weighted, >110 dB unweighted
Type IV dynamic range:	>119 dB, A-weighted, 22kHz BW >117 dB, unweighted, 22kHz BW
Sample Rate:	48kHz

D/A Performance:

Dynamic Range:	112 dB A-weighted, 109dB unweighted
----------------	-------------------------------------

System Performance:

Dynamic Range:	>110 dB A-weighted, >107dB unweighted,
THD+N:	0.003% typical at +4dBu, 1kHz, 0dB gain
Frequency Response:	20Hz – 20kHz, +/- 0.5dB
Interchannel Crosstalk:	>80dB typical
Crosstalk input to output:	>80dB
Propagation Delay	0.6 msec
Operating voltage:	100-240 VAC, 50/60Hz
Power Requirements:	27 Watts

Physical:

Weight:	6.0 lbs.(2.7 kg) Shipping weight 8.0 lbs. (3.6 kg)
Dimensions:	1.75” H x 8” D x 19” W
Safety Agency Certifications:	UL 60065, IEC 60065, E 60065, EN 55013

A.3 - Block Diagram

Zone Pro 1260/1261 Block Diagram

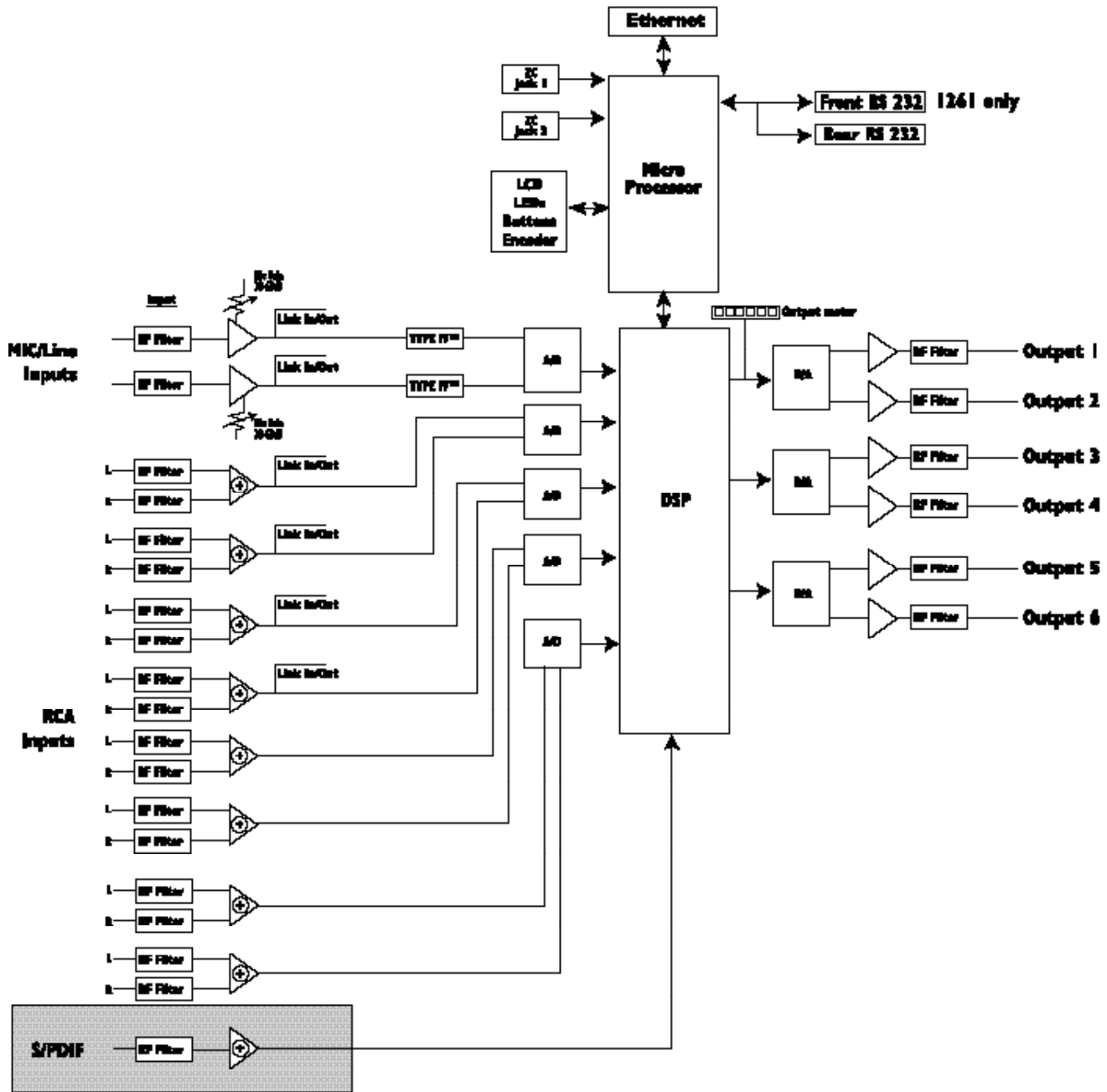

A.4 - Link Input/Output



CAUTION: These servicing instructions are for use by qualified service personnel only. To reduce the risk of electric shock, do not perform any servicing other than that contained in the operating instructions unless you are qualified to do so. Refer all servicing to qualified service personnel. Disconnect mains power before servicing.

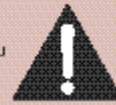

The link I/O connectors are used to pass program material from one box to another instead of using "Y" cables to feed multiple 1260's. The link connectors are RJ45's. The Mic/Line inputs and Source inputs 1-4 are fed to the Link Out. The program material coming out of the Link Out has not been processed by the DSP. The input signal is routed to the LinkOut connector. And the Link In is routed to the input circuitry. With the Link Out connected to another 1260/1261 Link Input, both units are processing the same program material. Multiple units can be daisy chained with the Link I/O for additional outputs from a single source. The Link I/O of the RCA inputs are always active. The mic/line inputs have selection jumpers inside the unit. These jumpers can be set to enable or disable Link In and or Link Out.

PI2-CH1



**Link Out Disabled
Link In Enabled**

PI8-CH2



**Link Out Disabled
Link In Disabled**



**Link Out Enabled
Link In Disabled**



**Link Out Enabled
Link In Enabled**

A.5 - Zone Controller Wiring and Install

Zone Controller Wiring

All Zone Controllers can be wired serially or in parallel. To wire in series, each Zone Controller must have an identification number (ID) chosen using the DIP switches on the side of the controller (see diagram A). Each controller must have a unique number chosen although there may be multiple Zone Controllers controlling a single zone, or a single Zone Controller that controls multiple outputs. The Zone Controllers can then be wired together and connected to the ZonePRO units (see diagram B).

To wire the Zone Controllers in parallel, a ZC-BOB must be used. Each Zone controller must have a unique identification or number chosen using the DIP switches on the rear of the panel (see diagram A). To wire in parallel, each controller must be wired into a port of the ZC-BOB with a connecting wire going to the ZonePRO units (see diagram C).

The ID numbers on the left side of the window correspond to the identification number set using the DIP switches on the individual zone controllers. To select ID#2 for example, simply flip the 2 switch into the on position. ID 1-6 are connected to top ZC input on the rear panel and ID 7-12 are connected to the bottom input. To create ID 7-12, add 6 to the ID # selected on the back of the ZC. For example, to get an ID# of 10, connect to the bottom ZC Input (7-12) and set the ID# to 4.

Zone Controller Installation

The installation of the Zone Controllers MUST be accomplished with the use of cable which is rated VW-1 or higher. Common NEC designations which meet this rating include: CMP, CMR, CMG, CM and CMX.

ZC-1 - The ZC-1 is a programmable zone controller that allows volume level control from a wall panel.

ZC-2 - The ZC-2 is a programmable zone controller that allows volume level and mute control from a wall panel.

ZC-3 - The ZC-3 allows wall panel program selection for the ZonePRO units.

ZC-4 - The ZC-4 provides contact closure program selection for room combining or fire safety applications applications.

ZC-Fire - The ZC-Fire is the interface to generic fire alarm relays. When fire alarm activates, the general purpose relay can typically be programmed to close if normally open or vices-versa. The ZC-fire interface unit monitors the state of the relay (n.o. or n.c.) and upon the state of change, notifies the ZonePRO, which then mutes its outputs.

ZC-6 - The ZC-6 is an up and down controller. Because the ZC-6 uses momentary switches, it does not override the ZonePRO's implantation of scheduled scene changes. The potentiometers used in ZC2 and ZC2 would override such a pre-scheduled scene change.

ZC-7 - The ZC-7 is used for momentary Mic Zone select.

ZC-8 - The ZC-8 is used for a combination of volume up/down, and four position source/program select.

ZC-9 - The ZC-9 allows wall panel program selection for the ZonePRO 1260 and 1261 units.

ZC-BOB - The ZC-BOB allows parallel or home run cabling of the Zone Controllers.

Diagram A

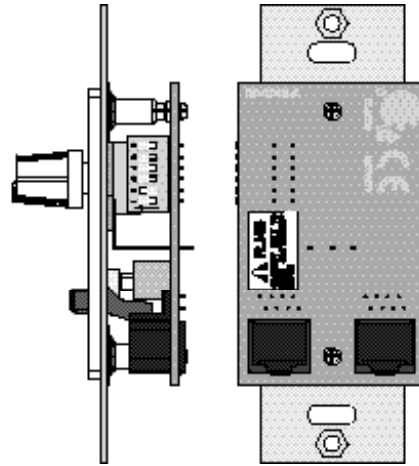

Diagram B

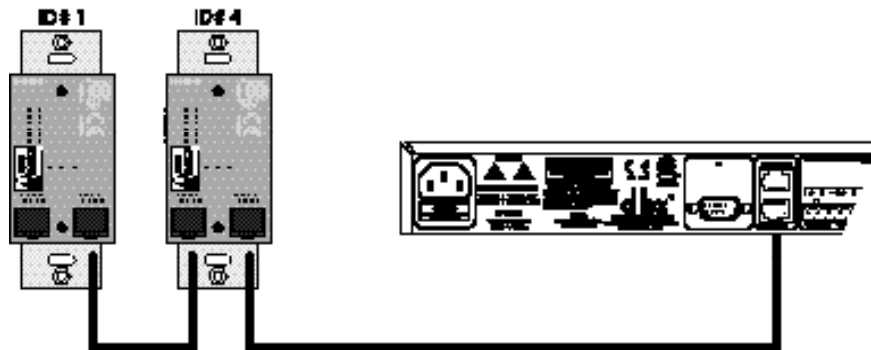
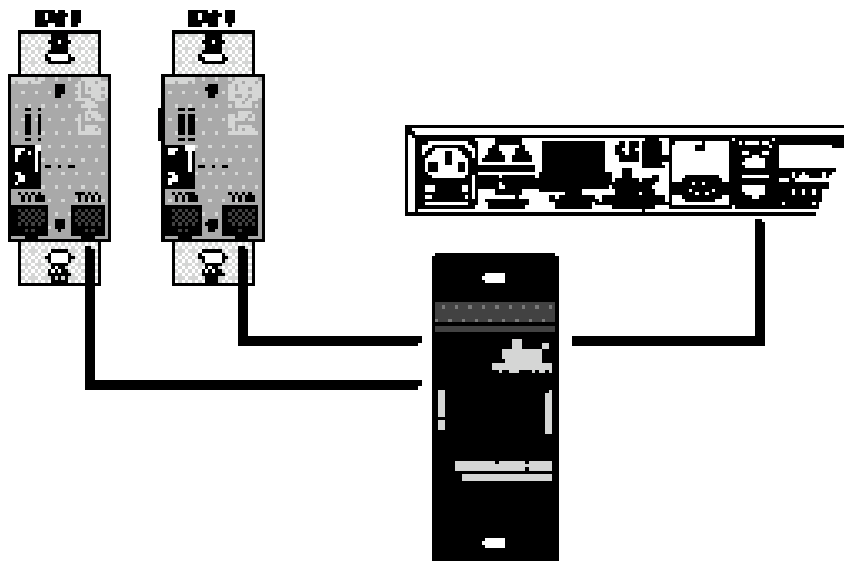

Diagram C



Cable Specification: Cat 5 Cable - 4-Twisted Pairs of 24 AWG wire

RJ-45 (8-Position)		RJ-45 (8-Position)
1	White/Orange	1 -VREF
2	Orange	2 -Zone 1
3	White/Green	3 -Zone 2
4	Blue	4 -Zone 3
5	White/Blue	5 -Zone 4
6	Green	6 -Zone 5
7	White/Brown	7 -Zone 6
8	Brown	8 -GND

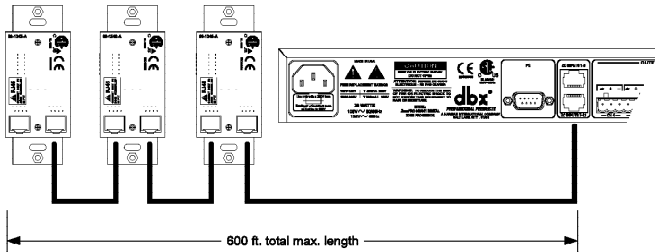

Diagram A

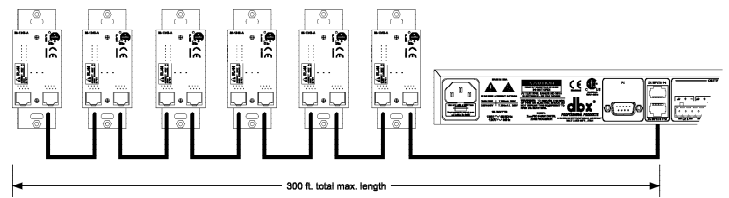

Diagram B

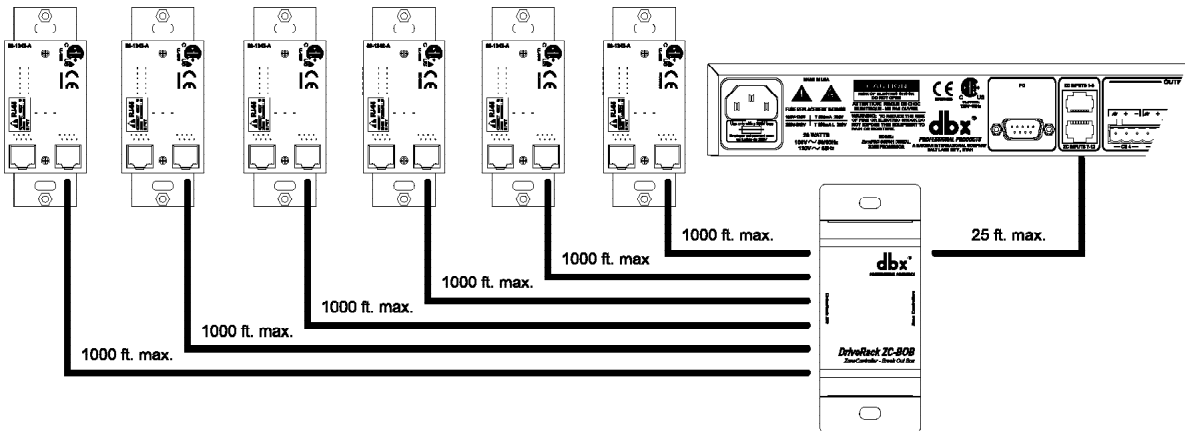

Diagram C

A.6 - Network Overview

This section of the appendix provides a step-by-step guide on how to properly connect and configure LAN settings for three different network architectures. The first topology is a simple direct connection using the provided Ethernet crossover cable. The second method describes how to connect several ZonePROs to an isolated network and configure them with the ZonePRO Designer GUI. The final configuration details how to add one or more ZonePRO units to an existing Local Area Network (LAN). The following subsections explain how and when to connect to a remote ZonePRO using the proxy feature and some tips and examples of how to access your ZonePRO by setting up a Virtual Private Network (VPN). This section of the appendix concludes with some further networking considerations and troubleshooting tips that will help with connecting to your ZonePRO unit via Ethernet.

Careful planning needs be made before placing a ZonePRO 1260/1261 on a network that provides any access to the public. Some examples of public access are direct access to the unit from the Internet, an unsecured or weakly secured wireless network, a network jack in a public area that provides network access to the ZonePRO, or having a computer on the LAN that is not secured so that someone could use the ZonePRO Designer software to reconfigure the 1260/1261. It is highly recommended that the equipment be placed on a protected, isolated network that does not have any connection to the public to prevent unauthorized users from reconfiguring the unit. Please refer to the VPN portion of this section for more information.

At the current time, the ZonePRO 1260/1261 only supports static IP configuration. In order to use Ethernet to manage the unit from the ZonePRO Designer GUI, modifications to the network settings may be needed on the PC and the ZonePRO 1260/1261.

Factory defaults for the Internet Protocol (IP) settings for the ZonePRO are as follows:

IP Address: 169.254.2.2
Subnet Mask: 255.255.0.0
Gateway: 0.0.0.0

The included cable is an Ethernet crossover cable. This means that the transmit and receive lines are crossed so that you can hook two Ethernet capable devices together without a hub or switch. If you are using a hub or switch you will need to provide your own cables.

A.6.1 Overview of TCP/IP Basics

Subnet: A small network within a larger network. For example, a TCP/IP network might be a subnet of a venue's network, which could include computers throughout the building, or a network might be divided into subnets. For example, in a large installation, there may be one subnet per rack or room.

IP address: An identifier for a computer or device on a TCP/IP network. Each device in a network has its own IP address to identify it. Example: 126.126.17.42. Networks using the TCP/IP protocol route messages based on the IP address of the destination. An IP address is made of four numbers separated by periods. Each number can be zero to 255. The last number should not be a zero or 255. For example, 126.126.17.1 could be an IP address. 126.126.17.0 would not be a valid IP address.

A TCP/ IP or IP address has two parts: the NETWORK ID and the HOST ID. The NETWORK ID identifies the network, and the HOST ID identifies either the subnet and device, or just the device if there is no subnet.

The subnet mask is a code that indicates which part of the TCP/IP address is the NETWORK ID and which part is the HOST ID. In subnet-mask code, 255 means “This part of the address is the NETWORK ID”.

Example:

Suppose the IP ADDRESS of a device is 192.168.12.34
and the SUBNET MASK is 255.255.0.0.

That means, (192.168) is the NETWORK ID. The remaining set of numbers (12.34) is the HOST ID. If your network stands alone (it is not part of a larger network) then the HOST ID identifies each device in the network. If your network is part of a venue's larger network, your network is actually a sub-network or subnet.

All devices in the network have the same network ID. There are many resources available on the Internet for IP and subnet calculation.

DHCP (Dynamic Host Configuration Protocol): This is a protocol for automatically assigning IP addresses to devices on a network. With dynamic (DHCP) addressing, a device might have a different IP address every time it connects to the network. If a computer is NOT connected to a network with a DHCP server, the computer will place a default network ID into the TCP/IP address and Subnet Masks.

ZonePRO does not use DHCP. A computer attached to a TCP/IP network must have its IP addresses assigned statically (manually).

A.6.2 Connecting via direct-connect Ethernet using the included crossover cable.

Assumptions:

- Using Microsoft Windows XP or 2000.
 - Computer has a working Ethernet network adapter.
 - You have administrative rights on the PC so that network settings can be changed if necessary.
1. Connect the included crossover Ethernet cable to both the ZonePRO and the PC. NOTE: A standard Ethernet cable will not work in this direct connect situation because common cables are designed to hook a device to a hub or switch.
 2. Apply power to the ZonePRO and wait for it to boot.
 3. Windows networking, in its default configuration, will automatically configure its IP setting to something in the Auto-IP range (169.254.xxx.yyy with a subnet mask of 255.255.0.0 and no gateway).
 4. **Wait** – The process of windows assigning an Auto-IP address normally takes 1-2 minutes.
 5. Optional (You only need to do these steps if the ZonePRO unit does not show up in step 7.)
 - verify that you have the correct IP settings on your computer by running ipconfig..
 - a. This is done by clicking on Run... from start button.
 - b. Enter cmd and press OK. This will bring up a command window (DOS box).
 - c. At the prompt enter ipconfig and press enter.
 - d. Now on your screen you will see your current IP settings. You should notice that the IP Address for the adapter will be either be 169.254.x.y where x and y are numbers between 0 and 255, or 0.0.0.0. If it is 0.0.0.0, wait for about a minute and enter the ipconfig com

mand again. (Windows is still trying to obtain an IP address.) It takes Windows about 1-2 minutes to set an Auto-IP address. If you have some other address, you are either not hooked directly to the ZonePRO with the crossover Ethernet cable, or your computer is configured with a static IP address.

Only perform these next steps if your computer is configured with a static IP address. (i.e. your IP address is not 169.254.x.y or 0.0.0.0.) Otherwise skip to step 6.

- i. From the control panel open the network connections window.
 - ii. Right click on the Local Area Network (LAN) connection that is wired to the ZonePRO and select 'Properties'.
 - iii. Highlight 'Internet Protocol (TCP/IP)' and then press the properties button.
 - iv. If 'Use the following IP address' radio button is selected, write down all the information on this page. The following steps will overwrite these settings, so you will need to keep this information to restore your network settings.
 - v. Select the 'Obtain an IP address automatically' radio button.
 - vi. (XP Only) Click on the Alternate Configuration tab and make sure that 'Automatic private IP address' is selected.
 - vii. Click OK in each window to close them.
 - viii. After about 1-2 minutes your computer will configure itself with the correct IP settings. Verify this by running the ipconfig command again, as described above.
6. Launch the ZonePRO Designer application. If it is currently running, make sure that you are not online by selecting 'Go Offline' from the Network menu. If it is already grayed-out, ZonePRO Designer is currently offline.
 7. Select '**Properties**' from the Network menu. Make sure that '**Use Ethernet**' is selected.
 8. Click **<Next>** again to enter the address tool. Ensure that there are no addressing conflicts. (Only ZonePRO Designer and the ZonePRO unit should show up, and their Node Addresses should already be different.) Close the Networking Wizard.
 9. Select '**Go Online**' from the Network menu. A **ZonePRO** icon will appear in the ZonePRO Designer. This indicates that you are online and the ZonePRO Designer software has discovered the ZonePRO unit.

A.6.3 Setup of a simple isolated Ethernet network:

Assumptions:

- Using Microsoft Windows XP or 2000.
 - Computer has a working Ethernet network adapter.
 - You have an Ethernet hub (or switch) and Ethernet cables for each connection needed. An integrated device such as a home gateway/router will not work because they have a DHCP server (see section A.6.4).
 - You have administrative rights on the PC so that network settings can be changed if needed.
 - The Ethernet network consists of exactly one computer that will be used to run the ZonePRO Designer software and one or more ZonePRO 1260/1260 units.
1. Connect the PC and any ZonePRO units to the hub using normal Ethernet cables. NOTE: The included crossover Ethernet cable should not be used. Crossover cables are only designed to connect two Ethernet adapters directly to each other.
 2. Apply power to all ZonePRO units and wait for them to boot.

3. Windows networking, in its default configuration, will automatically configure its IP setting to something in the Auto-IP range (169.254.xxx.yyy with a subnet mask of 255.255.0.0 and no gateway). This process normally takes 1-2 minutes.
4. **Optional** (You only need to do these steps if the ZonePRO unit does not show up in step 7.) - verify that you have the correct IP settings on your computer by running ipconfig.
 - a. This is done by clicking on Run... from start button.
 - b. Enter cmd and press **<OK>**. This will bring up a command window (DOS box).
 - c. At the prompt, enter ipconfig and press enter.
 - d. Now on your screen you will see your current IP settings. You should notice that the IP Address for the adapter will be either be 169.254.x.y where x and y are numbers between 0 and 255, or 0.0.0.0. If it is 0.0.0.0, wait for about a minute and enter the ipconfig command again. (Windows is still trying to obtain an IP address.) It takes Windows about 1-2 minutes to set an Auto-IP address. If you have some other address, your computer is configured with a static IP address.

Only perform these next steps if your computer is configured with a static IP address. (i.e. your IP address is not 169.254.x.y or 0.0.0.0.) Otherwise skip to step 5.

- i. From the control panel open the network connections window.
 - ii. Right click on the Local Area Network (LAN) connection that is wired to the ZonePRO and select 'Properties'.
 - iii. Highlight 'Internet Protocol (TCP/IP)' and then press the properties button.
 - iv. If 'Use the following IP address' radio button is selected, write down all the information on this page. The following steps will overwrite these settings, so you will need to keep this information to restore your network settings.
 - v. Select the 'Obtain an IP address automatically' radio button.
 - vi. (XP Only) Click on the Alternate Configuration tab and make sure that 'Automatic private IP address' is selected.
 - vii. Click OK in each window to close them.
 - viii. After about 1-2 minutes your computer will configure itself with the correct IP settings. Verify this by running the ipconfig command again, as described above.
5. Launch the ZonePRO Designer application. If it is currently running, make sure that you are not online by selecting 'Go Offline' from the Network menu. If it is already grayed-out, ZonePRO Designer is currently offline.
 6. Select 'Properties' from the Network menu. Make sure that 'Use Ethernet' is selected, and that the 'Proxies' list is empty. Click 'Next'.
 7. Click 'Next' again to enter the address tool. Ensure that there are no addressing conflicts. If this is the first time you are connecting to some of your ZonePRO units, you will need to resolve network conflicts. Each ZonePRO device must have a distinct IP address and Node Address. When all conflicts are resolved, close the Networking Wizard.
 8. Select 'Go Online' from the Network menu. A ZonePRO icon will appear in the ZonePRO Designer. This indicates that you are online and the ZonePRO Designer software has discovered the ZonePRO unit.

A.6.4 Adding the ZonePRO I260 to an existing Local Area Network:

Assumptions:

- Using Microsoft Windows XP or 2000.
 - Computer has a working Ethernet network adapter.
 - You have a static IP address that is compatible with your existing network.
 - There is an existing LAN where the computer that will be running the ZonePRO Designer software is able to attach to the LAN obtain an IP address and see other devices on this network.
1. Connect the ZonePRO unit to the network using a standard Ethernet cable. NOTE: The cable provided with the ZonePRO is a crossover cable and will not work for this application. See Section 1 for details on using the crossover cable.
 2. Apply power to the ZonePRO unit and wait for it to boot.
 3. Launch the ZonePRO Designer application. If it is currently running, make sure that you are not online by selecting 'Go Offline' from the Network menu. If it is already grayed-out, ZonePRO Designer is currently offline.
 4. Select 'Properties' from the Network menu. Make sure that 'Use Ethernet' is selected, Click 'Next'.
 5. Click 'Next' again to enter the address tool. It may take up to one minute for your new ZonePRO to show up in the device window.
 6. Click 'Change Address' to set the IP address of your ZonePRO unit. Contact your network administrator for an IP address, Subnet Mask, and Default Gateway that are appropriate for your network. Ensure that there are no addressing conflicts. If you see more than one ZonePRO unit, you may need to resolve network conflicts. Each ZonePRO device must have a distinct IP address and Node Address. When this is done and all network conflicts are resolved, close the Networking Wizard and the ZonePRO Designer application.
 7. Launch the ZonePRO Designer application and select 'Go Online' from the Network menu. A ZonePRO icon will appear in the ZonePRO Designer. This indicates that you are online and the ZonePRO Designer software has discovered the ZonePRO unit.

A.6.5 Proxy

The proxy feature allows you to access a ZonePRO over a complex or remote network. An example of this is when the PC and the ZonePRO reside on different subnets. The mechanism that is used by default for the ZonePRO designer software to discover and maintain a connection to the ZonePRO units utilizes IP broadcast packets. These packets will not travel through internet routers and even some high end core switches. In order to connect to one or more ZonePRO 1260/1261s that are attached to a complex network proxy is used to tell the Designer software where on the network to look for the ZonePRO devices. **There only needs to be one proxy setup for each group of ZonePROs that are on the same local network. The device that is the proxy will pass information to the other ZonePROs that it sees on the network that will allow them to connect to the ZonePRO Designer software.**

Follow these steps to setup a proxy connection:

1. Make sure that the ZonePRO has been correctly configured for the network that it is on and that the PC that is running the ZonePRO Designer software has a network connection to that 1260 / 1261 device. You should be able to ping from the windows box to the ZonePRO.
2. Select Properties from the Network menu of the main ZonePRO Designer window.
3. Make sure that "Use Ethernet" selected.
4. Select "Advanced."
5. Press the Add... button. The Add Proxy window will appear.
6. Enter the IP address or a host name for one of the ZonePRO devices on the remote network and click OK.
7. Press the Finish button to close the properties window.
8. Select Go Online from the Network menu. After a moment you will see your devices appear in the window.

If the ZonePRO Designer software can not establish a connection with the proxy you will receive a failure message after about one minute of trying to connect.

Proxy can be used to allow remote access to monitor and make minor changes to any ZonePRO 1260 or 1261 that is accessible from the internet. There are some things that can not be done over a proxy connection. For example, it is not possible for you to change the IP or node addresses over a proxy connection. Proxy is not intended for initial setup of any ZonePRO 1260/1261 it can only be used for remote monitoring and maintenance.

A.6.6 Virtual Private Networks (VPN)

Virtual private networks (VPN) provide an encrypted connection (or tunnel) between networks or between a network and a user over a public network (such as the Internet). Instead of using a dedicated, real-world connection such as leased line, a VPN uses virtual connections through the public network. The advantage to a VPN is that your computer can be virtually connected to a local network even though it is physically anywhere in the world where you have an internet connection. This can also be done in a safe manner not compromising your local network's security. If you would like to manage your ZonePRO 1260 / 1261s remotely you should create a secure VPN connection.

There are many solutions on the market today that provide VPN access. These products offer different features, methods of VPN, complexity of setup and maintenance, as well as varying levels of security. It is beyond the scope of this manual to recommend a VPN solution that will best suit the needs of your network, although you will need a VPN that is capable of passing

UDP and TCP traffic (most do). The ZonePRO 1260 / 1261 has been tested against several solutions and should work with all VPNs that meet these criteria. Please work with your system administrator and Internet service provider to find a VPN that will best fit your network.

The 3Com OfficeConnect Secure Router (model # 3CR860-95) is one solution that has been tested, and is both inexpensive and simple to set up. It provides up to two concurrent VPN connections. It works well with Microsoft Windows 2000 and XP built-in VPN interfaces.

A.6.7 Network Considerations and Limitations

- Without a VPN, there can be no access from the outside world to any 1260/1 that is behind a Network Address Translation (NAT) router. (One-to-One NAT and port forwarding will not work.)
- The address tool will not allow address changes on any 1260/1261 that is connected to the GUI via a proxy.
- When connecting to a 1260/1261 through a proxy, the locate tool will only work on the unit that is setup as the proxy, and not the devices that are connected through it.
- Only connect at a 10-Mbit rate. Any device that is forced to 100-Mbit or above will not link up. This will work at both 10 half and 10 full duplex.
- There is no auto sensing of the Ethernet Tx / Rx pairs. This means that if a hub switch is not used then, the user must connect to the device via an Ethernet crossover cable (supplied).
- There is a maximum of (10) 1260/1261 devices that can connect to the ZonePRO designer software at any given time.
- If the proxy link initially fails to connect, the user must go offline and then go back online before the proxy connection will be re-established.
- Firewall Considerations: The ZonePRO 1260 / 1261 uses port 3804 (udp and tcp) to communicate with the ZonePRO Designer software. Make sure that you configure your firewalls correctly so that data sent to and from this port number can traverse your network.

A.6.8 Network Troubleshooting

If you are having difficulty getting your ZonePRO 1260 / 1261 to show up in your ZonePRO Designer software here are some things that you can try to resolve the problem.

Software Firewall: If the PC that you have installed the ZonePRO Designer software on has a built in firewall you need to make sure that you allow the software the ability to talk on your network. Try disabling your firewall and then going offline and back online in the ZonePRO software. If this fixes the problem, refer to your firewall manufacturer's documentation on how to reconfigure your firewall to allow the ZonePRO Designer application and/or port 3804 tcp and udp to pass through the firewall.

Ethernet Link: Make sure that you have a valid Ethernet connection by looking at the link status lights. Most Ethernet devices will have some kind of indicator that shows the link is present. Check the following connections:

- ZonePRO device – If there is a valid connection on the 1260 / 1261 you will see a solid green LED.
- PC running the ZonePRO Designer software
- Hub / Switch (if used)

If you fail to see a link light try removing and reinserting the cable or trying a different, known good, cable. Also, make sure that you are using the correct cable. The included crossover cable is only for making a direct connection between your PC and the ZonePRO 1260 / 1261.

Ping: There is a simple utility built into Microsoft windows operating systems that test the network connection between two devices. The following steps outline how to use this utility.

1. Click on Run... from start button.
2. Enter **cmd** and press **OK**. This will bring up a command window.
3. At the prompt enter **PING <IP address of your ZonePRO>** and press enter. The data should appear something like this:

Pinging 10.10.10.1 with 32 bytes of data:

```
Reply from <IP address of your ZonePRO>: bytes=32 time<1 ms TTL=64
Reply from <IP address of your ZonePRO>: bytes=32 time<1 ms TTL=64
Reply from <IP address of your ZonePRO>: bytes=32 time<1 ms TTL=64
Reply from <IP address of your ZonePRO>: bytes=32 time<1 ms TTL=64
```

If you get a “reply from” response from the IP address that you were pinging in a timely manner, it means that you have a valid network connection between the two devices.

If you receive a “**Destination net unreachable**” or “**Request timed out**” message, this indicates that your computer is not communicating with the ZonePRO device.

A.7 - Copyrights

Portions of code are covered by the following copyrights:

X Consortium

Copyright (C) 1996 X Consortium

Permission is hereby granted, free of charge, to any person obtaining a copy of this software and associated documentation files (the "Software"), to deal in the Software without restriction, including without limitation the rights to use, copy, modify, merge, publish, distribute, sublicense, and/or sell copies of the Software, and to permit persons to whom the Software is furnished to do so, subject to the following conditions:

The above copyright notice and this permission notice shall be included in all copies or substantial portions of the Software.

THE SOFTWARE IS PROVIDED "AS IS", WITHOUT WARRANTY OF ANY KIND, EXPRESS OR IMPLIED, INCLUDING BUT NOT LIMITED TO THE WARRANTIES OF MERCHANTABILITY, FITNESS FOR A PARTICULAR PURPOSE AND NONINFRINGEMENT. IN NO EVENT SHALL THE X CONSORTIUM BE LIABLE FOR ANY CLAIM, DAMAGES OR OTHER LIABILITY, WHETHER IN AN ACTION OF CONTRACT, TORT OR OTHERWISE, ARISING FROM, OUT OF OR IN CONNECTION WITH THE SOFTWARE OR THE USE OR OTHER DEALINGS IN THE SOFTWARE.

Except as contained in this notice, the name of the X Consortium shall not be used in advertising or otherwise to promote the sale, use or other dealings in this Software without prior written authorization from the X Consortium.

X Window System is a trademark of X Consortium, Inc.

Berkeley-based copyrights:

General

Redistribution and use in source and binary forms, with or without modification, are permitted provided that the following conditions are met:

1. Redistributions of source code must retain the above copyright notice, this list of conditions and the following disclaimer.
2. Redistributions in binary form must reproduce the above copyright notice, this list of conditions and the following disclaimer in the documentation and/or other materials provided with the distribution.
3. The name of the author may not be used to endorse or promote products derived from this software without specific prior written permission.

THIS SOFTWARE IS PROVIDED BY THE AUTHOR "AS IS" AND ANY EXPRESS OR IMPLIED WARRANTIES, INCLUDING, BUT NOT LIMITED TO, THE IMPLIED WARRANTIES OF MERCHANTABILITY AND FITNESS FOR A PARTICULAR PURPOSE ARE DISCLAIMED. IN NO EVENT SHALL THE AUTHOR BE LIABLE FOR ANY DIRECT, INDIRECT, INCIDENTAL, SPECIAL, EXEMPLARY, OR CONSEQUENTIAL DAMAGES (INCLUDING, BUT NOT LIMITED TO, PROCUREMENT OF SUBSTITUTE GOODS OR SERVICES; LOSS OF USE, DATA, OR PROFITS; OR BUSINESS INTERRUPTION) HOWEVER CAUSED AND ON ANY THEORY OF LIABILITY, WHETHER IN CONTRACT, STRICT LIABILITY, OR TORT (INCLUDING NEGLIGENCE OR OTHERWISE) ARISING IN ANY WAY OUT OF THE USE OF THIS SOFTWARE, EVEN IF ADVISED OF THE POSSIBILITY OF SUCH DAMAGE.

UCB/LBL

Copyright (c) 1993 The Regents of the University of California. All rights reserved.

This software was developed by the Computer Systems Engineering group at Lawrence Berkeley Laboratory under DARPA contract BG 91-66 and contributed to Berkeley.

All advertising materials mentioning features or use of this software must display the following acknowledgement: This product includes software developed by the University of California, Lawrence Berkeley Laboratory.

Redistribution and use in source and binary forms, with or without modification, are permitted provided that the following conditions are met:

1. Redistributions of source code must retain the above copyright notice, this list of conditions and the following disclaimer.
2. Redistributions in binary form must reproduce the above copyright notice, this list of conditions and the following disclaimer in the documentation and/or other materials provided with the distribution.
3. All advertising materials mentioning features or use of this software must display the following acknowledgement: This product includes software developed by the University of California, Berkeley and its contributors.
4. Neither the name of the University nor the names of its contributors may be used to endorse or promote products derived from this software without specific prior written permission.

THIS SOFTWARE IS PROVIDED BY THE REGENTS AND CONTRIBUTORS "AS IS" AND ANY EXPRESS OR IMPLIED WARRANTIES, INCLUDING, BUT NOT LIMITED TO, THE IMPLIED WARRANTIES OF MERCHANTABILITY AND FITNESS FOR A PARTICULAR PURPOSE ARE DISCLAIMED. IN NO EVENT SHALL THE REGENTS OR CONTRIBUTORS BE LIABLE FOR ANY DIRECT, INDIRECT, INCIDENTAL, SPECIAL, EXEMPLARY, OR CONSEQUENTIAL DAMAGES (INCLUDING, BUT NOT LIMITED TO, PROCUREMENT OF SUBSTITUTE GOODS OR SERVICES; LOSS OF USE, DATA, OR PROFITS; OR BUSINESS INTERRUPTION) HOWEVER CAUSED AND ON ANY THEORY OF LIABILITY, WHETHER IN CONTRACT, STRICT LIABILITY, OR TORT (INCLUDING NEGLIGENCE OR OTHERWISE) ARISING IN ANY WAY OUT OF THE USE OF THIS SOFTWARE, EVEN IF ADVISED OF THE POSSIBILITY OF SUCH DAMAGE.

NVidia Corp

Copyright (c) 1996-1998 NVIDIA, Corp. All rights reserved.

NOTICE TO USER: The source code is copyrighted under U.S. and international laws. NVIDIA, Corp. of Sunnyvale, California owns the copyright and as design patents pending on the design and interface of the NV chips. Users and possessors of this source code are hereby granted a nonexclusive, royalty-free copyright and design patent license to use this code in individual and commercial software.

Any use of this source code must include, in the user documentation and internal comments to the code, notices to the end user as follows:

Copyright (c) 1996-1998 NVIDIA, Corp. NVIDIA design patents pending in the U.S. and foreign countries.

NVIDIA, CORP. MAKES NO REPRESENTATION ABOUT THE SUITABILITY OF THIS SOURCE CODE FOR ANY PURPOSE. IT IS PROVIDED "AS IS" WITHOUT EXPRESS OR IMPLIED WARRANTY OF ANY KIND. NVIDIA, CORP. DISCLAIMS ALL WARRANTIES WITH REGARD TO THIS SOURCE CODE, INCLUDING ALL IMPLIED WARRANTIES OF MERCHANTABILITY AND FITNESS FOR A PARTICULAR PURPOSE. IN NO EVENT SHALL NVIDIA, CORP. BE LIABLE FOR ANY SPECIAL, INDIRECT, INCIDENTAL, OR CONSEQUENTIAL DAMAGES, OR ANY DAMAGES WHATSOEVER RESULTING FROM LOSS OF USE, DATA OR PROFITS, WHETHER IN AN ACTION OF CONTRACT, NEGLIGENCE OR OTHER TORTIOUS ACTION, ARISING OUT OF OR IN CONNECTION WITH THE USE OR PERFORMANCE OF THIS SOURCE CODE.

8760 South Sandy Parkway • Sandy, Utah 84070

Phone: (801) 568-7660 • Fax (801) 568-7662

Int'l Fax: (801) 568-7583

Questions or comments?

E-mail us at: customer@dbxpro.com or visit our

World Wide Web home page at:

www.dbxpro.com

H A Harman International Company