

Minilyzer ML1

User Manual



NTI CONTACT

Headquarter: NTI AG
Im alten Riet 102
FL- 9494 Schaan
Liechtenstein, Europe
Tel +423 - 239 6060
Fax +423 - 239 6089
E-mail info@nt-instruments.com
Home www.nt-instruments.com

Subsidiary: NTI (Montreal)
3520 Griffith Street
St. Laurent
Quebec H4T 1A7
Canada
Tel +1 - 514 - 344 5220
Toll free +1 - 800 - 661 6388
Fax +1 - 514 - 344 5221
E-mail canada@nt-instruments.com

© NTI AG
All rights reserved.
Subject to change without notice.
Release 2.0 / July 2001 / Software V2.00
Printed in Liechtenstein.

Minilyzer, Minirator, MiniSPL and Minstruments are registered trademarks of NTI (Neutrik Test Instruments).

TABLE OF CONTENTS

1. INTRODUCTION	1-01
1.1 CE Declaration of Conformity	1-01
1.2 International Warranty and Repair	1-02
1.3 Warnings	1-03
1.4 Overview	1-04
1.5 Battery Replacement	1-05
2. BASIC OPERATION	2-01
2.1 Power ON/OFF - Backlight	2-02
2.2 Escape	2-02
2.3 Enter / Cursor Control	2-03
2.4 Display Mode	2-03
2.5 Menu Bar	2-04
2.6 Inputs and Monitor Output	2-08
2.7 Music Detection	2-08
3. MEASUREMENT FUNCTIONS	3-01
3.1 Level RMS	3-01
3.2 Level Relative	3-02
3.3 Level SPL	3-03
3.4 THD+N	3-08
3.5 vu+PPM	3-09
3.6 Polarity	3-11
3.7 Signal Balance Error	3-12
3.8 Sweep	3-13
3.9 1/3 rd Octave RMS	3-17
3.10 1/3 rd Octave SPL	3-18
3.11 Scope	3-20
4. TROUBLESHOOTING	4-01
4.1 System Break Down	4-01
4.2 Low Level Measurements	4-01
5. ACCESSORIES	5-01
5.1 MiniSPL	5-01
5.2 ML1 Adapter -20dB	5-01
5.3 Pouch	5-02
5.4 Minstruments System Case	5-02
5.5 Copy Cable	5-02
6. TECHNICAL SPECIFICATION	6-01
6.1 Technical Data General Functions	6-01
6.2 Technical Data Acoustic Functions	6-03

1. INTRODUCTION

Congratulations and thank you for buying NTI's Minilyzer ML1, a product specially suited for professional audio applications. The Minilyzer offers advanced analysis functions, expected only in much larger and more expensive systems. We are convinced you will enjoy using it!

NTI products are manufactured in compliance with the highest quality standards and marked with the CE sign.

In order to avoid any damage to the unit, we strongly recommend to read the entire manual before you start using the instrument.

1.1 CE Declaration of Conformity

We, the manufacturer

NTI AG
Im alten Riet 102
FL- 9494 Schaan
Liechtenstein, Europe

hereby declare that the product Minilyzer ML1, released in 2000, conforms to the following standards or other normative documents.

EMC-Directives: 89/336, 92/31, 93/68

Harmonized Standards: EN 61326-1

This declaration becomes void in case of any changes on the product without written authorization by NTI.

Date: 01.04.2000

Signature:

Position of Signatory:

TECHNICAL DIRECTOR



1.2 International Warranty and Repair

International Warranty

NTI guarantees the Minilyzer and its components against defects in material or workmanship for a period of **one year** from the date of original purchase, and agrees to repair or to replace at its discretion any defective unit at no cost for either parts or labor during this period.

Restrictions

This warranty does not cover damages caused through accidents, misuse, lack of care, the attachment or installation of any components that were not provided with the product, loss of parts, connecting the instrument to a power supply, input signal voltage or connector type other than specified, or wrongly polarized batteries. In particular, no responsibility is granted for special, incidental or consequential damages.

This warranty becomes void if servicing or repairs of the product are performed by any party other than an authorized NTI service center or if the instrument has been opened in a manner other than specified in this manual.

No other warranty, written or verbal, is authorized by NTI. Except as otherwise stated in this warranty, NTI makes no representation or warranty of any kind, expressed or implied in law or in fact, including, without limitation, merchandising or fitting for any particular purpose and assumes no liability, either in tort, strict liability, contract or warranty for products.

Repair of your Minilyzer ML1

In case of malfunction, take - or ship prepaid - your NTI Minilyzer packed in the original box, to the authorized NTI representative in your country. For contact-details please see the NTI web page: www.nt-instruments.com

Be sure to include a copy of your sales invoice as prove of purchase date. Transit damages are not covered by this warranty.

1.3 Warnings

In order to avoid any problems during the operation of the instrument, follow the rules listed below:

- **Read this manual thoroughly before you operate the instrument for the first time.**
- **Use the instrument for the intended purpose only.**
- **Never connect the instrument to a high voltage output such as a power amplifier, mains power plug, etc.**
- **Do not disassemble the instrument.**
- **Never use the instrument in a damp environment.**
- **Remove the batteries as soon as they are flat or if the instrument is not intended to be used for a longer period of time.**

1.4 Overview

The Minilyzer ML1 is a sophisticated audio test instrument, supporting a wide range of useful measurement functions. The results are displayed on a large LCD with backlight:

- Level RMS, Relative or SPL (Sound Pressure Level)
- THD+N (Total Harmonic Distortion + Noise)
- vu-Indicator and PPM (Peak Program Meter)
- Frequency
- Polarity Test (in combination with NTI's Minirator MR1)
- Signal Balance Error
- Sweep recording with respect to frequency or time
- 1/3rd Octave Spectrum RMS or SPL
- Scope

Additionally, several input filters are available, depending on the active measurement function:

- A-weighting acc. IEC 60651
- C-message acc. CCIR 468-4
- 22 Hz Highpass acc. DIN 45045, -120 dB / dec.
- 60 Hz Highpass acc. DIN 45045, -120 dB / dec.
- 400 Hz Highpass acc. DIN 45045, -120 dB / dec.
- Voice Bandpass acc. ITU-T P.48
- C-weighting acc. IEC 60651
- X-Curve⁻¹ acc. ISO 2969

The X-Curve⁻¹ filter is especially applicable for the recording, monitoring and play-back of wide range soundtracks in indoor theatres, review rooms or cinemas. To measure the acoustic response in such rooms e.g. the Minirator MR1 shall be used with the pink noise signal selected. Via the Minilyzer the 1/3rd octave spectrum has to be recorded using the X-Curve⁻¹ filter. According the ISO-norm the result shall be a flat graph (a continuous noise spectrum having constant energy per 1/3rd octave bandwidth).

A setup screen allows to adjust four settings according to the specific demands of the user:

- Auto power off duration
- Auto backlight off duration
- LCD contrast
- Multiple setup (individual settings for up to 4 users)

1.5 Battery Replacement

After unpacking, insert three (3) pcs. 1.5 V alkaline batteries, type AA, LR6, AM3 into the ML1 battery compartment as shown in Fig 1 and Fig 2. The typical life-time for a set of alkaline batteries is 16 hours.



Fig 1 Open Battery Compartment



Fig 2 Inserted Batteries

- NOTES**
- We do not recommend to use rechargeable NiCd- or NiMH-batteries.
 - Do not insert batteries of different types.
 - Note the correct polarities of the inserted batteries.
 - Remove the batteries as soon as they are flat.

2. BASIC OPERATION

Despite the wide range of available measurement functions and optional setups, the operation of the Minilyzer is almost self-explanatory.

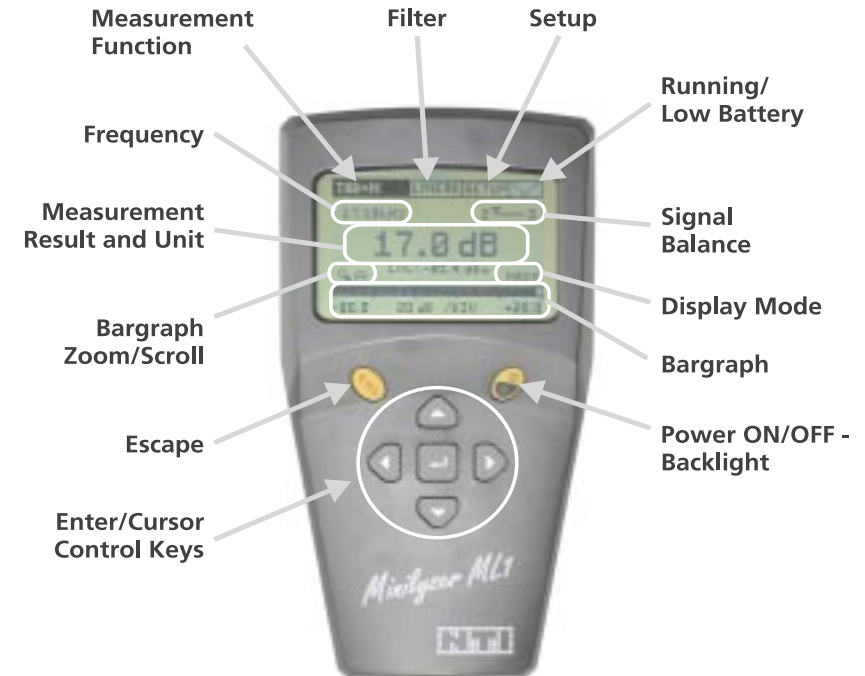

Fig 3 Display & Control Elements

The LCD is divided in the menu bar on top (measurement function, filter, setup and running / low battery) and the results displayed below are showing various information's about the current status.

The cursor control keys and the escape button allow straightforward navigation through the available features to quickly get the required information's like

- Actual setup (measurement function, filters)
- Status of the unit / batteries
- Measurement results (numerical values and bargraph).

2.1 Power ON/OFF - Backlight

The yellow, oval-shaped key on the right hand side has the following functions:

- Device on, press and hold it for at least one second to turn the unit on.
- Backlight, press it shortly to activate the backlight.
- Device off, press and hold it for at least two second to turn the unit off.

The Minilyzer will start up in the same mode (e.g. measurement function) and with the same settings as it was switched off the last time. In case the setup screen has been selected at switching off the unit, the previous measurement function will be entered.

The backlight may be activated at any time, without affecting the settings of the unit.

Please note that the ML1 has independent auto power off functions for main power and the backlight. These may be adjusted separately (see 2.5.c Setup).

2.2 Escape

The yellow key on the left-hand side labeled ESC, activates the escape (exit) function and may be selected at any time. Depending on the instrument status, pressing the ESC-key performs the following functions:

- No menu is open, the cursor returns to its default position (top left field).
- A selection menu is open, the menu gets closed, resetting the unit to the status in which it was opened.
- In the SETUP mode, the executed changes are saved and the previous measurement mode is recalled.

In other terms, by pressing the ESC-key maximum twice, the unit is reset to the last active status and the cursor returns to its default position.

2.3 Enter / Cursor Control

The cursor is the core control element of ML1, providing access to its menus and to the current instrument settings. The cursor position is represented by an inverted display (white on black) of the field holding the cursor.

The cursor may be moved from menu to menu by using the four gray arrow keys ←, →, ↑ and ↓. The enter key (↵) has to be pressed to enter a submenu or to confirm the current selection.

To modify the menu status execute the following procedure:

- Move the cursor to the field of interest and press the enter key.
- Scroll to the required menu option by using the arrow keys.
- Confirm your selection by pressing the enter key.

Please note that in certain selection modes, the measurement result will be updated with the new selection even before the enter key has been pressed for confirmation.

For instance, if a new level unit is selected - but not yet confirmed - the display will instantly update to the newly selected unit even before the enter key has been pressed for confirmation.

In case of an unwanted change of any menu, the old status may be re-established by pressing the ESC-key.

2.4 Display Mode

Giving a better readability the display mode determines the rapidity of following up input signal changes. The available modes are:

- SLOW 3 sec. averaging
- NRM 1 sec. averaging
- FAST no averaging

If averaging is active, measurements are smoothed in an exponential way (exponential time constant) before being displayed.

2.5 Menu Bar

The menu bar, located at the top of the LCD, allows the user to select the measurement function, to activate a filter or to enter the setup screen. The field on the right hand side displays the battery voltage status of the unit.

To make any selection move the cursor to one of the menu bar fields and press the enter key.

a. Selection of Measurement Function

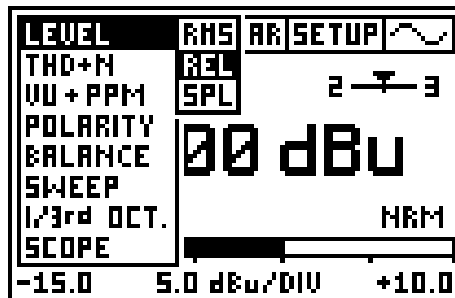

Fig 4 Example of Function Submenu

The entries of the pull down menu (Fig 4) are the following:

- LEVEL RMS
- LEVEL REL - the RMS input level relative to a user-defined reference level
- LEVEL SPL - sound pressure level
- THD+N - total harmonic distortion and noise
- vu + PPM - volume indicator and peak program meter, selectable standards are Type I, Type IIA, Nordic
- POLARITY - analysis function corresponding to the Minirator MR1 polarity test signal, acquired either by direct cable connection or through the built-in microphone of ML1
- BALANCE - the signal balance error quantitates the level deviation between pin 2 and pin 3 of the XLR input connector
- SWEEP - sweep recording with respect to frequency or time
- 1/3rd OCT. RMS - one third octave spectrum of line input signal
- 1/3rd OCT. SPL - one third octave spectrum of microphone input signal, sound pressure level
- SCOPE - the time graph of the input signal

b. Selection of Filters

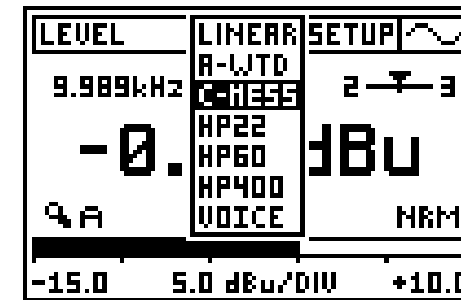

Fig 5 Example of Filter Submenu

There are two sets of filters with the following characteristics available:

Set 1:

LINEAR	Linear frequency response (no filtering)
A-WTD	A-weighting filter acc. IEC 60651
C-MESS	C-Message filter acc. CCIR Rec. 468-4
HP22	Highpass 22 Hz acc. DIN 45045, -120 dB/dec.
HP60	Highpass 60 Hz acc. DIN 45045, -120 dB/dec.
HP400	Highpass 400 Hz acc. DIN 45045, -120 dB/dec.
VOICE	Voice band filter acc. ITU-T P.48

Set 1 filters are applicable with the measurement functions LEVEL RMS, LEVEL REL, THD+N and SWEEP.

Set 2:

LINEAR	Linear frequency response (no filtering)
A-WTD	A-weighting filter acc. IEC 60651
C-WTD	C-weighting filter acc. IEC 60651
X-CRV ⁻¹	inverted X-Curve filter acc. ISO 2969

Set 2 filters are applicable with the measurement functions LEVEL-SPL and 1/3rd OCT., whereby the X-CRV⁻¹ filter is enabled in the 1/3rd OCT. mode only.

Any selected filter will stay active until it is disabled by the user. However, if the filter is not supported by the measurement function, it will be disabled automatically.

c. Setup

The setup screen allows to customize basic settings of the Minilyzer ML1 by the following procedure:

- Move the cursor to the corresponding field and press enter
- Select the required status by using the arrow keys
- Press the enter key to confirm

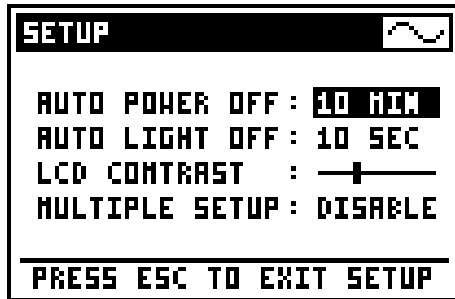

Fig 6 Setup Screen

AUTO POWER OFF defines the time after the ML1 is switched OFF automatically after the last key-press. The available settings are 3 MIN, 10 MIN, 30 MIN, 60 MIN and DISABLE. In case DISABLE is selected, the user has to turn the unit off manually or it will run until the batteries are discharged.

AUTO LIGHT OFF defines how long the backlight stays on after being activated. Possible selections are 3 SEC, 10 SEC., 60 SEC. and DISABLE. In the latter case, the backlight will stay on, until the unit is switched off. The longer the backlight is turned on, the shorter is the lifetime of the batteries.

LCD CONTRAST adjusts the contrast of the display. Alternatively, press the ESC and up/down arrow key simultaneously in any measurement panel.

MULTIPLE SETUP allows four users to store their individual settings. To enable the multiple setup mode, set the corresponding entry to ENABLE and confirm. At the next the Minilyzer is switched on, the user will have to select the individual setup-ID (1, 2, 3 or 4) in the startup screen (Fig 7). All parameter settings in all measurement modes are now stored under this ID at switch off and are recalled if this ID is selected at the next start up.

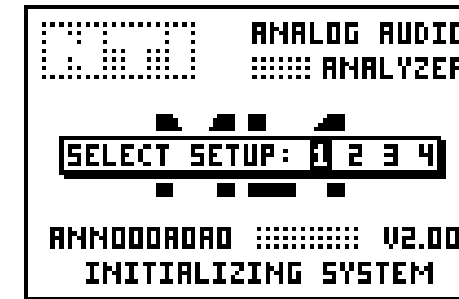

Fig 7 Multiple User Startup Screen

NOTE Only the last recorded sweep curves will be stored independent on the selected user setup.

d. Indicator for Operation / Low Battery

In the right hand field of the ML1 menu bar, a moving sine symbol indicates the unit is running properly.

Alternatively, if the inserted batteries are almost exhausted, this field will show a battery-low indicator (Fig 8)

NOTE As soon as the batteries are discharged, they must be removed from the ML1, in order to avoid damage due to leakage.



Fig 8 Low Battery Indicator

2.6 Inputs and Monitor Output

On top of the ML1, three connectors as well as the internal microphone are located (Fig 9):

- The XLR and RCA inputs allow to feed a signal to the ML1.
- A 3.5 mm (1/8") jack monitor output allows the connection of a headphone. Thus, the user may hear the input signal.
- The internal microphone provides the possibility to test the polarity of an acoustical signal if the NTI's Minirator MR1 polarity check signal is played back. This especially serves to check the polarity of loudspeakers.

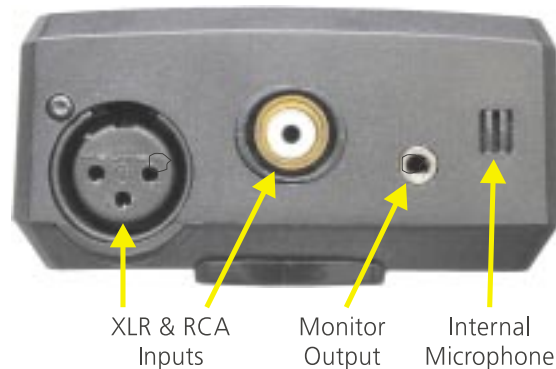

Fig 9 Inputs and Outputs of ML1

NOTE Never connect the XLR- and the RCA input at the same time!

2.7 Music Detection

Automatic gain control is applied to the input signal before being analyzed and made audible from the monitor jack. In this mode, the monitor signal behaves similar like a compressor output, whereby the user hears an almost constant sound pressure level. For input levels lower -20 dBu the gain is set to +20 dB.

NOTE The automatic music detection is only available in the measurement functions LEVEL RMS, LEVEL REL, THD+N, POLARITY, BALANCE, SWEEP and SCOPE.

3. MEASUREMENT FUNCTIONS

3.1 Level RMS

LEVEL RMS reflects the absolute level of the line input signal.

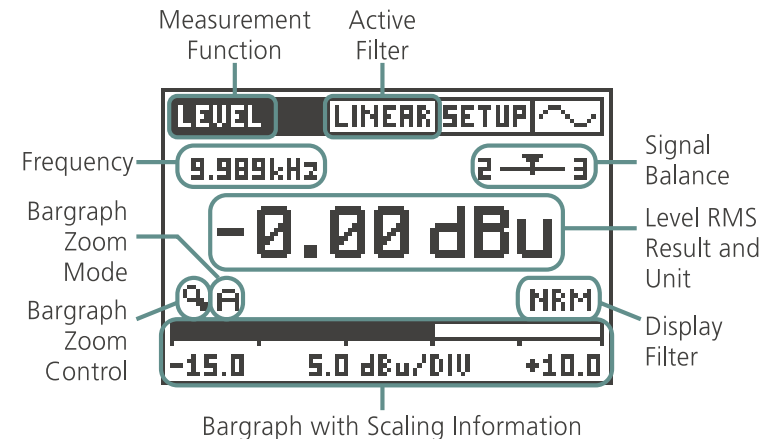

Fig 10 Level RMS Meter Panel

To enter the LEVEL RMS mode, select LEVEL -> RMS in the measurement functions submenu.

Signal Balance: This indicates the deviation from level-match of the incoming balanced signal between pin 2 and pin 3 in percent (%). The position of the arrow indicates the following:

- Arrow in center, the input signal is balanced.
- Arrow out of center, linear indication of a balancing problem, e.g. arrow moves left nearer to the number 2 shows the signal level on pin 2 is higher than on pin 3.
- Left or right end, the signal balance error is 33% or higher. 33% equals a difference in the signal level of 6 dB.
- UNBAL, the signal balance symbol changes to UNBAL at the signal balance error exceeding 90%.

Result and Unit: Level RMS. The units dBu, dBV or V may be selected.

Bargraph: The bargraph provides an analog display of the RMS level. The scaling may be controlled automatically or manually.

- Select manual (M) or automatic (A) scaling by the bargraph zoom mode field.
- Within the manual scaling (M) select the bargraph zoom control, press enter and the left/right keys to scroll through the

actual range or the up/down keys to increase or decrease the range (sensitivity) of the bargraph scale.

- Press enter to confirm your setting.

Display Filter: see 2.4. Display Mode

- NOTES**
- For balanced input levels higher than +20 dBu, the ML1 Adapter -20dB may be applied. (for details see 5. Accessories).
 - The LEVEL RMS function is also available in the SWEEP mode (see 3.8) and in 1/3rd OCT. RMS mode (see 3.9).

3.2 Level Relativ

This function measures the input RMS level, relative to a user-defined reference level (Fig 11).

The reference level has to be defined in the following way:

- Select the LEVEL REL mode
- Apply the intended reference level to a ML1 input connector.
- Move the cursor to the REF field below the main result line and press the enter key.

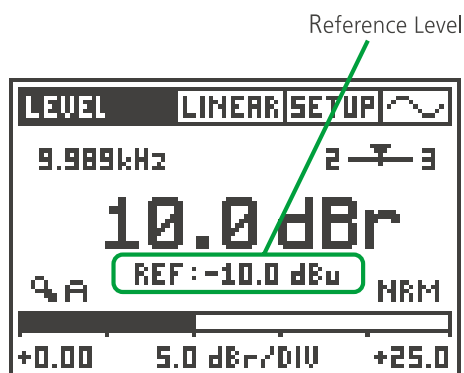

Fig 11 Level Relative Meter Panel

This stores the applied level as the current reference level for all further level relative measurements until a new reference level is set. The level relative is indicated in dB_r (dB relative) or %.

The level relative function may be used to measure the signal-to-noise ratio (S/N) of a device under test (DUT) in the following manner:

- Set the unit of the level relative measurement to dB_r.
- Connect the DUT output to the ML1 and mute the DUT output.
- Adjust the reference level to this signal as described above. By this, the 'noise' signal of the DUT is acquired.
- Enable the DUT, thus applying the signal to the ML1. The resulting level relative value reflects the S/N ratio in dB.

3.3 Sound Pressure Level

In the LEVEL SPL mode the Minilyzer measures the integrated-averaging level over time, the actual, minimum and maximum sound pressure level.

- NOTES**
- For this function a self powered microphone is required. NTI does recommend to use the accessory MiniSPL (for details see 5. Accessories).
 - Prior the first measurement the Minilyzer has to be calibrated to the microphone specifications. As default the ML1 is calibrated according the MiniSPL.
 - No phantom power is available on the XLR-input.

a. Sound Pressure Level Panel

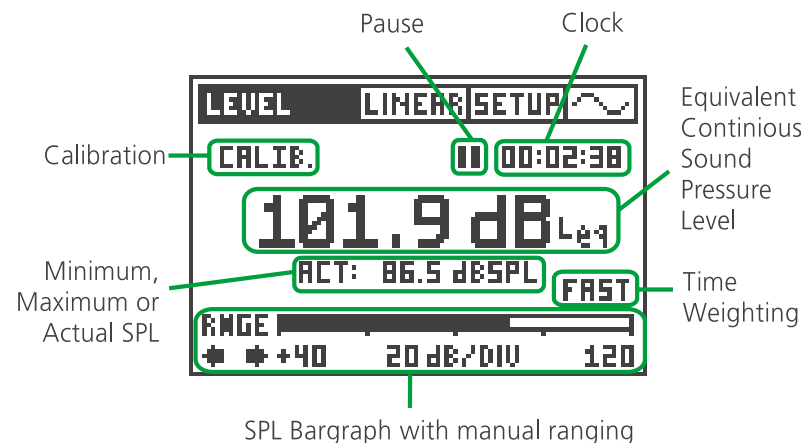

Fig 12 Sound Pressure Level Panel

To enter the LEVEL SPL mode (Fig 12), select LEVEL -> SPL in the measurement functions submenu.

Start of measurement: The sound pressure level measurement is re-started every time

- The LEVEL SPL screen is entered
- The filter selection is changed.
- The clock is reset.
- The time weighting selection is changed.
- The bargraph range selection (RNGE) is changed.

Sound Pressure Level: The equivalent continuous sound pressure level (also time-averaged sound level) is indicated in dBL_{eq} , dBL_{Aeq} , dBL_{Ceq} , depending on the selected filter in the filter menu.

Example:

- select in the main menu the filter A-WTD
- the measurement unit is changing to dBL_{Aeq} and the minimum, maximum and actual sound pressure level readings below are A-weighted.

Below the time-averaged SPL reading one of the following values may be displayed (select with the cursor keys):

- ACT: actual sound pressure level (SPL)
- MIN: minimum sound pressure level acquired during the measuring time indicated by the clock. The minimum value is stored until a new lower reading has been taken.
- MAX: maximum sound pressure level acquired during the measuring time indicated by the clock. The maximum value is stored until a new higher reading has been taken.

Pause: The L_{eq} and min./max. measurement may be frozen for a user defined time.

- Select the pause symbol and press the enter key.
- The pause symbol is flashing.
- The actual SPL reading is continuously displayed and not frozen.
- Select the pause symbol and press the enter key to continue the measurement, visible by the continuing counting clock.

Clock: Duration in hours:minutes:seconds of the actual measurement; select the clock and press the enter key to reset the time and restart the measurement.

Time weighting: All sound pressure level measurements include time weighting. A change in sound pressure level is read out on the display with a shorter or longer response time.

Available response times, corresponding to IEC 60651, are

- SLOW (long attack- and release time)
- FAST (short attack- and release time)
- IMP (=impulse, very short attack and long release time)

Bargraph: The bargraph provides an analog display of the actual sound pressure level.

Available bargraph ranges are:

- 20 - 100 dB_{SPL}
- 40 - 120 dB_{SPL}
- 60 - 140 dB_{SPL}

The selected bargraph range complies to the measurement range of the instrument. To achieve accuracy of the measurement within the specified tolerances the proper range must be selected, called primary indicator range. The two range indicator arrows assist to set the Minilyzer to the optimal range. As soon as the indicated bargraph value is found lower than the primary indicator range, the down arrow symbol below RNGE will start to move, symbolizing the actual bargraph reading is inaccurate. The lower bargraph range needs to be changed manually by selecting the moving left arrow symbol and pressing the enter key.

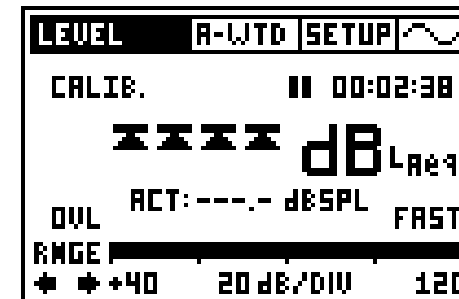

Fig 13 SPL Panel with Overload

By exceeding the primary indicator range four overload arrows replacing the dBL_{eq} reading and no reading below is shown (see Fig. 13). Select the right arrow below RNGE and press enter to change to the next higher bargraph range. In case signal clipping has occurred the term OVL is flashing above the RNGE field as long as this peak, is significant influencing the integrating sound pressure level reading. For example an SPL peak for 0.1 sec. will have effects to the L_{eq} reading for several seconds but it's contribution can be neglected after ten minutes.

b. Calibration Panel

The Minilyzer ML1 enables the calibration of microphones, such as the MiniSPL.



Fig 14 Calibration Panel

Select CALIB. in the LEVEL SPL panel field. Press the enter key and the calibration screen SET SENSITIVITY ... will be displayed (Fig 14). The following three calibration modes are available:

TO DEFAULT MINISPL-MIC: All MiniSPL are factory calibrated to a sensitivity of 20.0 mV/Pa. Reset to default setting:

- Select the GO! field on the left.
- Press the enter key to start.
- OK! is shown to confirm the completed calibration.

USING EXT. REF.: The sensitivity may be adjusted with an external calibrator to produce a certain calibrated sound pressure level.

- Select the dB_{SPL}-value, press the enter key and adjust with the cursor keys the sound pressure level generated by the calibrator. Use up/down keys for 1.0 dB_{SPL} steps and left/right keys for 0.1 dB_{SPL} steps. The setting range 80 - 140 dB_{SPL} is supported.
- Confirm the setting with the enter key.
- Produce the specific reference signal with the calibrator to the microphone attached.
- Press the left cursor key to select the GO! field and press enter to execute the calibration, whilst the reference signal of the calibrator is still present.
- The frame WORKING ... followed by the frame CALIBRATION FINISHED! is shown centered on the calibration screen if all has been found in good order (see Fig 15). Otherwise various error indications may be displayed to inform the user about the

detailed calibration problem.

- The new sensitivity is calculated by the Minilyzer and shown below USING EXT. REF.: in mV/Pa.
- Press the ESC button to exit the calibration mode and return to the LEVEL SPL screen.
- Check the calibration by applying the reference signal again to the attached microphone. The sound pressure level of the calibrator shall be shown to confirm the calibration is carried out in good order.

Error indications will appear during the calibration caused by low/high input level or the calculated sensitivity is out of the range 2 - 80 mV/Pa.

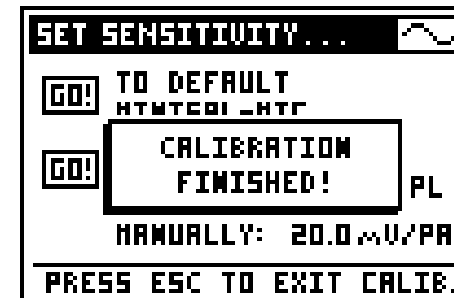

Fig 15 Calibration Finished

MANUALLY:

- Select the setting value xx.x mV/Pa.
- Press enter and select with the cursor keys the sensitivity according to the attached microphone, use up/down keys for 1.0 mV/Pa steps and left/right keys for 0.1 mV/Pa steps. The setting range 2 - 80 mV/Pa is supported.

Simply press the ESC button to exit from the calibration screen back to the LEVEL SPL screen. The new measurement is started immediately.

3.4 THD+N

In this mode the Minilyzer measures the THD+N (Total Harmonic Distortion + Noise).

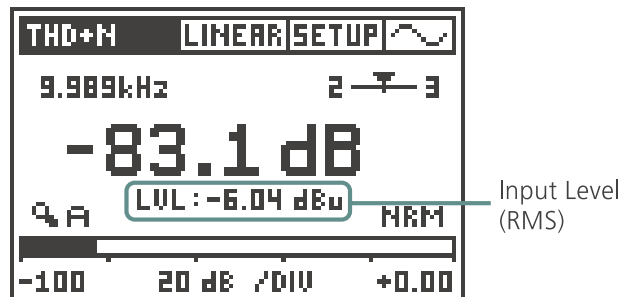

Fig 16 THD+N Meter Panel

The measurement is carried out in the band from 10 Hz - 20 kHz, expressed in dB or in %. Simultaneously, the LCD shows the actual RMS input level below the THD+N result.

NOTE The THD+N results are calculated using a restricted measuring bandwidth of 10 Hz - 20 kHz.

Besides checking the linear purity of a sine signal - e.g. measuring amount of harmonic distortions - this measurement mode is particularly suited to get a quick idea whether unwanted disturbances like hum are present.

3.5 vu + PPM

ML1 provides vu + PPM (Peak Program Meter) measurement results, following IEC60268.

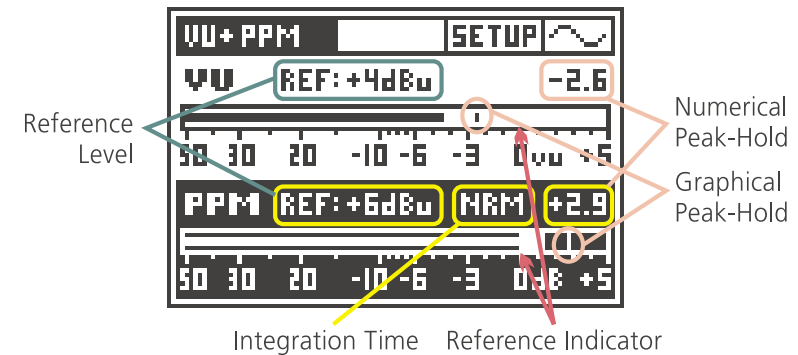

Fig 17 vu + PPM (Type I) Panel

The PPM may be measured according to three standards:

- Type I
- Type IIA
- Nordic standard

One of these standards has to be selected when entering the vu+PPM mode through the measurement functions menu.

The following chapters describe the different entry fields and indicators of the vu+PPM display.

a. Reference Level & Indicator

The reference level indicates the RMS level of a 1 kHz sine wave that defines the value of the reference indicator. The reference level may be defined by the user in a range of -20 dBu to +14 dBu.

The default reference level depends on the selected standard

- +4 dBu for the vu-meter
- +6 dBu for the PPM standards Type I and Nordic
- +8 dBu for the PPM standard Type IIA.

The following examples explain the correlation between the reference level and the reference indicator.

Example 1

Given vu-meter reference level set to +4 dBu
Input signal = steady-state sine wave of +4 dBu

Result vu meter level = 0 (reference indicator level)

Example 2

Given vu-meter reference level set to 0 dBu
Input signal = steady-state sine wave of +4 dBu

Result vu-meter level = +4 (+4 dB above reference indicator)

Example 3

Given PPM Nordic standard, reference level set to +12 dBu
Input signal = steady-state sine wave of +6 dBu

Result PPM level = TST (-6 dBu below reference indicator level)

b. Peak Hold

There are two different types of peak hold on the vu+PPM screen:

- Two numerical peak hold indications, located above the right hand end of the vu and the PPM bargraph. The numerical peak hold indicates the all-time max. input level since the vu+PPM mode has been entered. It may be reset by placing the cursor to it and pressing the return key. To reset the two numerical peak-hold simultaneously, simply re-enter the vu+PPM mode.
- Two graphical peak hold indications, represented by a vertical line in each bargraph. The graphical peak hold display has a decay time of approximately one second.

c. Integration Time

The PPM display provides an additional entry field to select the attack and release times between NRM (normal) and FAST.

- In the NRM mode, the value of the integration time is given by the corresponding standard (Type I: 5 ms; Type IIA: 10 ms; Nordic: 5 ms)
- In the FAST mode, the integration time is 1 ms for all standards.

3.6 Polarity

In combination with the Minirator MR1, the Minilyzer provides a powerful feature to detect the polarity of the signal at the output of a device.

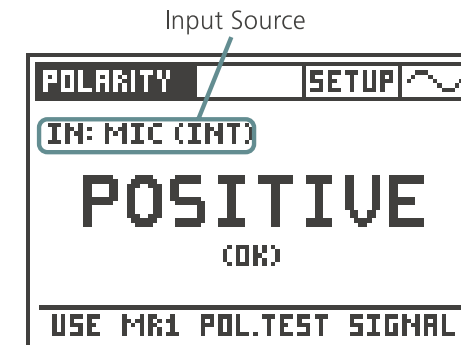

Fig 18. Polarity Test Screen

This function may be applied to check for example the

- polarity of loudspeakers
- condition of balanced cables

In order to execute a polarity test, proceed as follows:

- Connect the MR1 to the input connector of the device.
- Activate the PolTest-signal of MR1 and adjust the level.
- Enter the polarity measurement function of ML1.
- Select the input source
 - MIC(INT), the internal microphone or
 - XLR/RCA, input-connectors
 by placing the cursor to the IN: entry field, press enter, select with the arrow keys and confirm your setting with enter again.

- NOTES**
- **Place the internal microphone close to the speaker to be tested in order to evaluate its polarity.**
 - **To ensure reliable readings reduce the level of low frequencies, e.g. bass or subwoofer.**
 - **The polarity test may be carried out with the external microphone MiniSPL (select XLR/RCA as input source).**

An overrange indicator appears for levels exceeding the instruments operating range. In this case increase the distance between microphone and loudspeaker or reduce the volume.

3.7 Signal Balance Error

The signal balance error reflects the deviation from the perfect balance status. No signal balance error indicates that the absolute levels at XLR-pin 2 and pin 3 relative to pin 1 (ground) are identical and opposite in polarity.

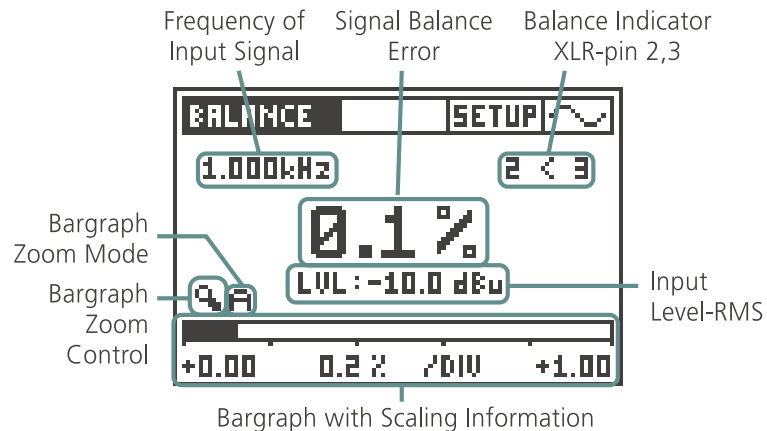

Fig 19 Signal Balance Error Screen

In the BALANCE mode, the signal balance error is shown in a numerical value, which is the deviation from the optimum in percent.

Balance Indicator: The direction of the deviation is indicated by the arrows like 2 < 3 or 2 > 3, whereby the numbers 2 and 3 represent the signal at XLR-pin 2 and pin 3.

In the Level, THD+N and Polarity (electrical input only) measurement function, the Minilyzer permanently monitors the balance of the input signal by a graphical indicator. This enables e.g. to check whether cable connections are made correctly.

Bargraph: The bargraph shows an analog display of the signal balance error. The scaling may be controlled automatically or manually.

- Select manual (M) or automatic (A) scaling by the bargraph zoom mode field.
- Within the manual scaling press the left/right keys to scroll through the actual range or the up/down keys to increase or decrease the range (sensitivity) of the bargraph scale.
- Press enter to confirm your setting.

3.8 Sweep

ML1 supports two sweep modes:

- LEVEL RMS as function of frequency
- LEVEL RMS, THD+N and Frequency as function of time

The required sweep mode may be selected through the SWEEP entry of the measurement function submenu.

a. Frequency Sweep

During a frequency sweep, ML1 records the LEVEL RMS of every input signal that has a stable frequency and level, provided that the frequency is higher than the one of the previous sample (otherwise the sample will be neglected).

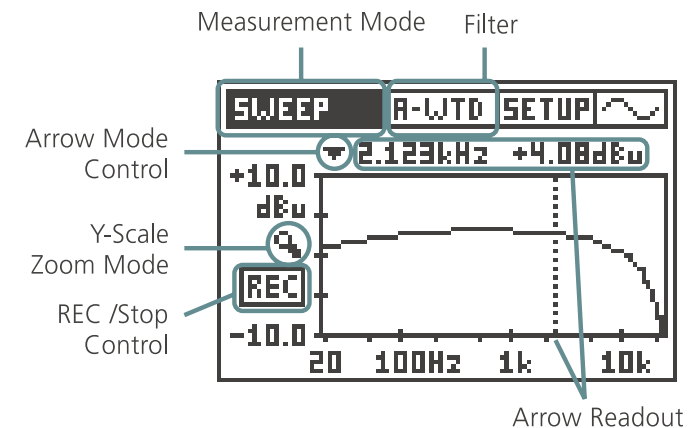

Fig 20 Frequency Sweep Graph

Within a graph, every recorded sample is connected by a straight line approximation to the previous/next sample, thus building the displayed curve (Fig 20).

In practice, the following steps are required / available for the execution of a frequency sweep.

- To enter the frequency sweep mode, select in the measurement function submenu SWEEP -> FREQ.
- If required activate a filter through the corresponding menu.

- Arm the sweep recording process by moving the cursor to the REC field and press the enter key. Make sure that the signal generator is at its lowest sweep frequency when the recording process is starting.
- The unit detects the start tone (315 Hz or 1 kHz) of an external sweep and as soon the frequency changes the recording is automatically started. This status is indicated by the flashing REC field.

Alternatively, the sweep recording may be started manually by pressing the enter key with the cursor on the ARM field. Consequently, ML1 records every incoming signal with a higher frequency than the previous sample.

- The sweep recording will be stopped as soon as an input signal with a lower frequency occurs, or as soon as the enter key is pressed with the cursor on the flashing REC field.
- In order to analyze the sampled curve more detailed, activate the arrow mode by placing the cursor to the corresponding symbol, press the enter key, and move the arrow to the sample(s) of interest by using the left / right keys.
- To zoom in/out the Y-axis, move the cursor to the zoom mode field, press enter and use the left / right keys.
- To scroll through the Y-axis, move the cursor to the zoom mode field, press enter and use the up / down keys.

The last recorded sweep curve will be stored internally, even after leaving the sweep mode or switching off the Minilyzer. As soon as the frequency sweep mode is re-entered, the curve will re-appear on the graph, until a new frequency sweep is started.

- NOTES**
- **As soon as the sweep mode is entered, the filter that has been active during the recording of the last curve will be re-activated.**
 - **The auto power off is disabled during a frequency sweep recording.**

b. Time Sweep

In the TIME SWEEP mode, ML1 records a user-defined number of measurements in selectable time intervals.

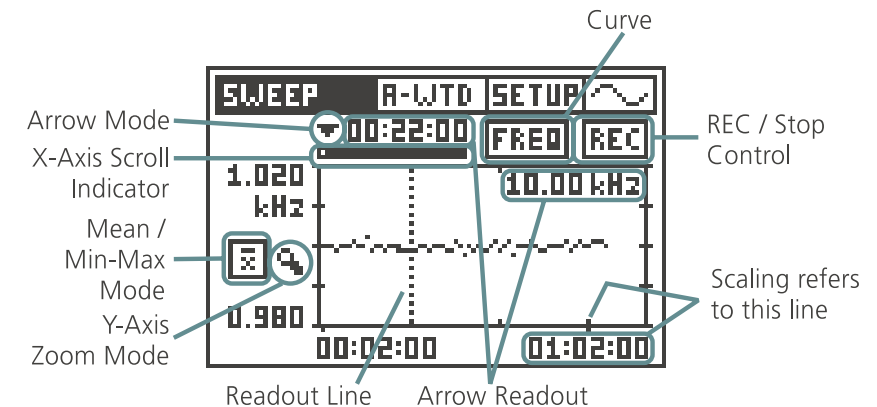

Fig 21 Time Sweep Graph

Thereby, the unit simultaneously records the mean and the min-max values of:

- LEVEL RMS and
- THD+N and
- Frequency

The curves of these measurement functions are stored in individual graphs. Within a graph, every sample is represented by a single dot only, thus building the displayed curve (Fig 21).

In practice, the following steps are required / available for the execution of a time sweep:

- To enter the time sweep mode, select the entry SWEEP → TIME in the measurement function submenu.
- If required, activate a filter through the corresponding menu.
- To select the curve to be displayed (LEVEL RMS, THD+N or Frequency) move the cursor to the curve entry, press enter key, use the arrow keys and confirm with the enter key.
- To select the mean / min-max mode, move the cursor to the corresponding field, press enter and the arrow keys. The curve and the mean/min-max mode can also be selected after the sweep recording is completed.
- Move the cursor to the REC field and press enter.

A dialog box will open (Fig 22) on the graph, where the sweep duration (min. 60 sec - max. battery lifetime) and the recording interval (≥ 1 sec) have to be entered. Please note that the number of samples must be between 60 - 1600.

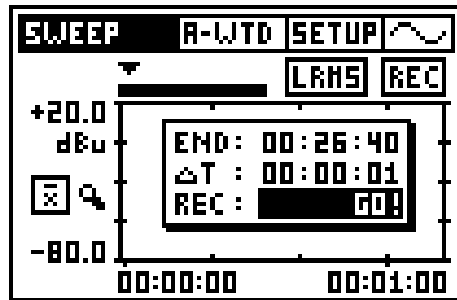

Fig 22 Time Sweep Setup

- To start the sweep recording, move the cursor to the GO! field and press enter.
- The time sweep automatically stops when the defined duration has expired. Alternatively, the sweep may be stopped manually by pressing enter with the cursor on the REC field.
- To display the mean or the min-max values of the recorded sweep, place the cursor to the corresponding field and select the required mode by using the enter and the arrow keys.
- In order to analyze the sampled curve more detailed, activate the arrow mode by placing the cursor to the corresponding symbol and pressing the enter key. Move the readout line to the sample(s) of interest by using the left / right keys, or press the up/down keys to zoom out/in the X-axis.
- To zoom in/out the Y-axis, move the cursor to the zoom mode field, press enter and
 - use the up/down keys to zoom out/in the Y-axis
 - use the left/right keys to scroll through the Y-axis.

The last time sweep recording will be stored internally, even after leaving the sweep mode or switching off the Minilyzer. As soon as the time sweep mode is re-entered, the last displayed curve will appear on the graph, until a new time sweep recording is started.

- NOTES**
- **As soon as the sweep mode is entered, the filter that has been active during the recording of the last curve will be re-activated.**
 - **If a running time sweep is stopped due to empty batteries, the recorded data will not be lost.**
 - **The auto power off is disabled during a time sweep.**

3.9 1/3rd Octave RMS

The 1/3rd OCTAVE RMS screen shows the signal frequency spectrum of the line-in signal, divided into 31 bands.

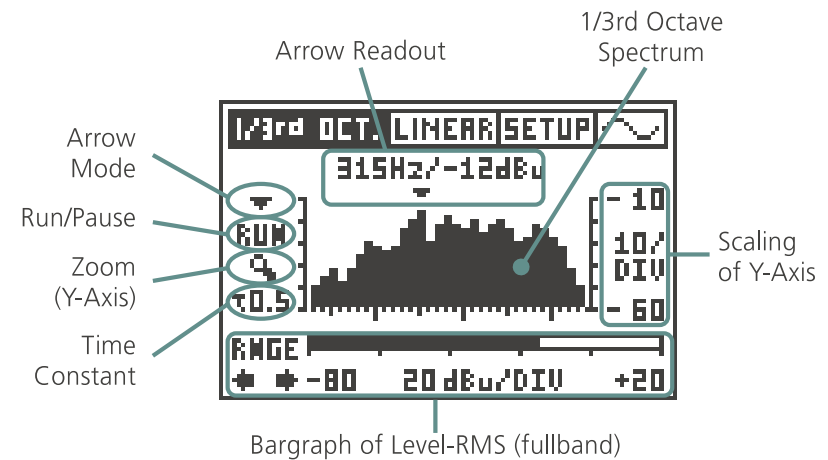

Fig 23 1/3rd Octave RMS Screen

To enter the 1/3rd OCTAVE RMS mode (Fig 23), select 1/3rd OCT. -> RMS in the measurement functions submenu.

Arrow Readout: The arrow readout displays the frequency and the level of the 1/3rd octave band that it points to. The arrow automatically points to the highest level in the 1/3rd octave spectrum, or, alternatively may be controlled manually.

Arrow Mode: The arrow readout may be moved manually to a certain specific 1/3rd octave band.

- Select the arrow mode field and press the enter key.
- Move the arrow to any frequency by using the left/right keys.

Run/Pause: The 1/3rd octave spectrum may be freed.

- Select the run/pause field and press the enter key.
- The 1/3rd octave spectrum is freed.
- The arrow mode or zoom symbol may be selected for the detailed read out of the 1/3rd octave spectrum.
- At selecting any other field the measurement will be continued.
- Press the enter key again to continue the measurement.

Zoom (Y-Axis): The scaling of the spectrum's Y-axis (sensitivity) is fixed and may be adjusted manually.

- Select the zoom (Y-axis) field and press the enter key.
- Use the up/down keys to scroll the displayed level along the Y-axis and the left/right keys zoom out/in the Y-axis, e.g. alter the resolution of the division.

Time Constant: The time constant corresponds to the integration time of the 1/3rd octave recording. It may be set to five value: 0.2 / 0.5 / 1.0 / 2.0 / 5.0 seconds. A lower time constant results in a quicker, more 'nervous' display, whilst a higher time constant 'averages' more samples, thus providing a more stable spectrum.

Bargraph: Below the spectrum, the fullband input RMS level (20 Hz - 20 kHz) is indicated by a bargraph without auto ranging. Select the different indication ranges by moving the cursor to the left or right arrow below RNGE and press enter. The available ranges are:

- -120 to -20 dBu, residual noise of ML1 < -120dBu (<1 μ V), enables measurement of low signal levels
- -100 to 0 dBu
- -80 to +20 dBu, please note in this range the residual noise of ML1 is gained by 20 dBu.

3.10 1/3rd Octave SPL

The 1/3rd OCTAVE SPL screen shows the signal frequency spectrum of the acoustic signal, divided into 31 bands.

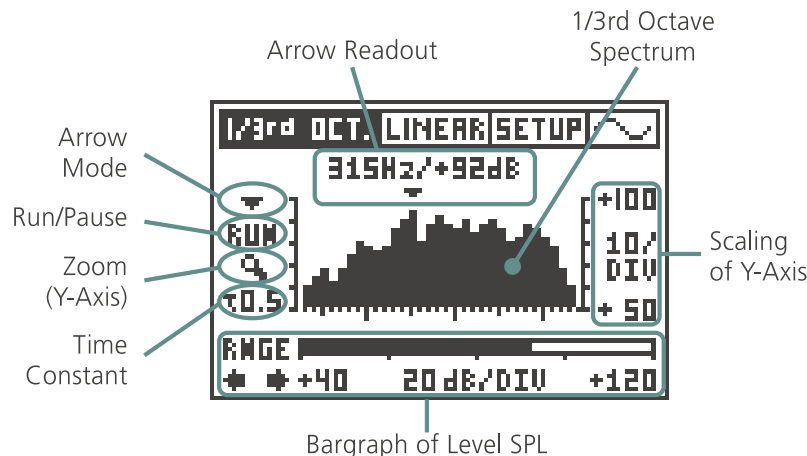

Fig 24 1/3rd Octave SPL Screen

To enter the 1/3rd OCTAVE SPL mode (Fig 24), select 1/3rd OCT. -> SPL in the measurement functions submenu.

Arrow Readout: The arrow readout displays the frequency and the level of the 1/3rd octave band that it points to. The arrow automatically points to the highest level in the 1/3rd octave spectrum, or, alternatively may be controlled manually.

Arrow Mode: The arrow readout may be moved manually to a certain specific 1/3rd octave band.

- Select the arrow mode field and press the enter key.
- Move the arrow to any frequency by using the left/right keys.

Run/Pause: The 1/3rd octave spectrum may be frozen.

- Select the run/pause field and press the enter key.
- The 1/3rd octave spectrum is frozen.
- The arrow mode or zoom symbol may be selected for the detailed read out of the 1/3rd octave spectrum.
- At selecting any other field the measurement will be continued.
- Press the enter key again to continue the measurement.

Zoom (Y-Axis): The scaling of the spectrum's Y-axis (sensitivity) is fixed and may be adjusted manually.

- Select the zoom (Y-axis) field and press the enter key.
- Use the up/down keys to scroll the displayed level along the Y-axis and the left/right keys zoom out/in the Y-axis, e.g. alter the resolution of the division.

Time Constant: The time constant corresponds to the integration time of the 1/3rd octave recording. It may be set to five value: 0.2 / 0.5 / 1.0 / 2.0 / 5.0 seconds. A lower time constant results in a quicker, more 'nervous' display, whilst a higher time constant 'averages' more samples, thus providing a more stable spectrum.

Bargraph: Below the spectrum, the actual sound pressure level is indicated by a bargraph. Select the different indication ranges by moving the cursor to the left or right arrow below RNGE and press enter. The available bargraph ranges are:

- 20 - 100 dB_{SPL}
- 40 - 120 dB_{SPL}
- 60 - 140 dB_{SPL}

3.11 Scope

To activate the SCOPE mode, select the entry SCOPE in the measurement functions menu.

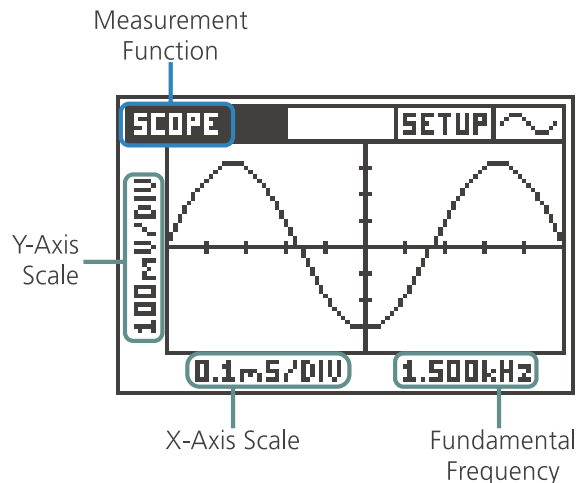

Fig 25 Scope Screen

The SCOPE screen visualizes the waveform of the input signal. It automatically triggers to the fundamental frequency and selects the scaling of the X-axis (time) and Y-axis (level) accordingly.

Furthermore, the input signals fundamental or most dominant frequency is displayed near the lower right corner of the scope screen.

NOTE The scaling of the SCOPE display cannot be changed manually.

4. TROUBLESHOOTING

4.1 System Break Down

- Switch the device off.
- Reset the ML1 to the default status by pressing the ESC button and switching the Minilyzer on simultaneously.
- Release the ESC button.
- The below screenshot, Fig 26, shall appear on the display, stating on the bottom line LOADING DEFAULT SETUP.
- Verify the correct operation.

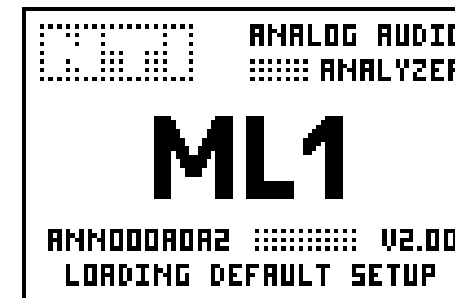

Fig 26 Start Up Screen Loading Default Setup

In case you find system breakdowns happening several times or your device is malfunctioning please contact the local NTI representative in your country. For contact-details please see the NTI web page: www.nti-instruments.com

4.2 Low Level Measurements

The Minilyzer does automatically recognize the actual input (XLR or RCA) in use. To measure low level audio signals (< 70 dBu) the balanced input shall be used only. Unbalanced signals need to be connected to the XLR-input via an XLR/RCA-adapter.

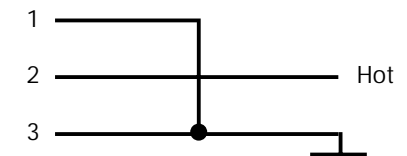

Fig 27 XLR/RCA Adapter

5. ACCESSORIES

5.1 MiniSPL

The MiniSPL is the perfect accessory for acoustical measurements. Together with the Minilyzer ML1 a comprehensive integrating sound level meter is formed.

The MiniSPL is a self contained omni directional 1/2" measuring microphone with built in impedance converter, pre-amplifier and power supply. It is battery powered and the XLR-output is balanced. The MiniSPL is classified as type 2 in accordance with IEC 60651.



Fig 28 MiniSPL

5.2 ML1 Adapter -20dB

For balanced input levels higher than +20 dBu, the ML1 Adapter -20dB may be applied. This passive adapter extends the balanced input range of your Minilyzer up to +40 dBu. Simply add 20 dBu to the displayed value in the LEVEL RMS mode or use the LEVEL REL mode, setting the reference level to -20 dBu.



Fig 29 ML1 Adapter -20 dB

5.3 Pouch

The soft pouch protects your Minstrument against shocks, dust and water. With its convenient belt-clip you can keep your Minstrument close to you even when you need both hands for other tasks.



Fig 30 ML1 Pouch

5.4 Minstruments System Case

Store your valuable Minstruments test system consisting of the Minirator MR1, the Minilyzer ML1 and the MiniSPL adequately in the compact system case which gives you extra space for cables, connectors and other accessories you may wish to bring along when you are 'out in the fields' checking audio systems.



Fig 31 System Case

5.5 Copy Cable

The Copy Cable allows to update the software of your Minilyzer ML1 and adds the latest available features. Simply link two Minilyzers with the Copy Cable and directly update the software from one Minilyzer to another.



Fig 32 Copy Cable

6. TECHNICAL SPECIFICATION

6.1 Technical Data General Functions

Measurements	- Frequency - Level-RMS, Level-Relative - THD+N - vu+PPM - Polarity Test - Signal Balance Error - Sweep, Frequency Sweep, Time Sweep - 1/3 rd Octave Spectrum - Scope
Frequency	
Range	10 Hz to 20 kHz
Resolution	4 digits
Accuracy	< ± 0.1 %
Level	
Units	dBu, dBV, V_{RMS}
Resolution	3 digits (dB-scale) or 4 digits (V-scale)
Accuracy	± 0.5 % @ 1 kHz
Bandwidth	20 Hz to 20 kHz
Flatness	± 0.1 dB
THD+N (Total Harmonic Distortion + Noise)	
Meas. Bandwidth	10 Hz to 20 kHz
Resolution	3 digits (dB-scale) or 4 digits (%-scale)
Residual THD+N	balanced < -85 dB @ -10 dBu to +20 dBu unbalanced < -74 dB @ 0 dBu to +14 dBu
vu+PPM (vu-Indicator and Peak Program Meter)	
	according to IEC 60268 and DIN 45406. PPM Type I, IIa and Nordic. Both meters with adjustable reference and with analog & numerical peak-hold readout.
Polarity Test (with MR1 test signal)	
	Positive / Negative detection through internal microphone or XLR/RCA connector. Checks polarity of tweeters, midrange-speakers, woofers, sub-woofers and cables down to 10 dB S/N input signal.

Signal Balance Error	Indication range 0.0 % to 100 % Deviation from perfect balance in % or *1
Sweep	Frequency Sweep: Level as function of frequency. Time Sweep: Measurement of level, THD+N and frequency as function of time.
1/3rd Octave	Spectrum acc. IEC 1260, class II and ANSI S1.11-1976, class II from 50 Hz to 20 kHz, Bargraph for Level _{RMS} 20 Hz to 20 kHz
Scope	Auto triggering, auto ranging, auto scaling
Filters	Linear, A-weighting, C-weighting, C-message, Highpass 22 Hz / 60 Hz / 400 Hz, X-Curve ⁻¹ , Voice bandpass
Input Connectors	XLR balanced, RCA unbalanced
Input Impedance	40 kOhm balanced, 20 kOhm unbalanced
Input RMS¹ (upper meas. limit)	balanced +20 dBu ($7.75 V_{RMS}$) unbalanced +14 dBu ($3.8 V_{RMS}$)
Max. DC Input	± 50 V _{DC}
Residual Noise	< 12 µV, XLR-input shorted
Microphone Input (for Polarity measurement only)	Omnidirectional
Monitor Output	Jack 3.5 mm (1/8"), suitable for all common headsets
Display	Graphic LCD 64 x 100 pixel, with backlight
Batteries	3x AA package dry batteries (alkaline) Typical battery lifetime > 16 hrs
Dimensions (L x W x H)	163 x 86 x 42 mm (6.4" x 3.38" x 1.63")
Weight	300 g (10.5 oz) incl. batteries
Temperature	0° to +45° C (32° to 113° F)
Humidity	< 90 % R.H., non condensing

¹ for input levels > 20 dBu (balanced) the ML1 Adapter -20 dB is available

6.2 Technical Data Acoustic Functions

(firmware 2.00 or higher, applicable with MiniSPL only)

Measurements - Sound Pressure Level
 - 1/3rd Octave Spectrum

Acoustical Functions

in accordance with IEC60651 and IEC 60804

- Instantaneous Sound Pressure Level (Lp)
- Maximum/Minimum Sound Pressure Level (Lmax/Lmin)
- Time Response selectable
- Weighting Filters
- Equivalent Continuous Sound Pressure Level (Leq)
- Pause- and Continue Function

Sound Pressure Level

Units	dB _{SPL} , dB _{Leq} , dB _{LAeq} , dB _{LCeq}		
Resolution	3 digits		
Display Ranges	20 - 140 dB _{SPL} in 3 bands	20 - 100 dB _{SPL}	40 - 120 dB _{SPL}
			60 - 140 dB _{SPL}
Bandwidth	20 Hz to 20 kHz		
Flatness	According to class 1		

Time Response Selectable fast, slow, impuls

Weighting Filters Selectable A, C, linear, X-Curve⁻¹

Integration Pause- and Continue Function

1/3rd Octave Spectrum

31 octave band display 20 Hz to 20 kHz,
 selectable filters A, C, linear,

Sensitivity Selectable default value (MiniSPL),
 calibration to external source,
 editable sensitivity value

Quick Guide Minilyzer ML1



Measurement Function Menu:

