

2001RB BASSAMP & 2001RBP PREAMP

Owner's Manual

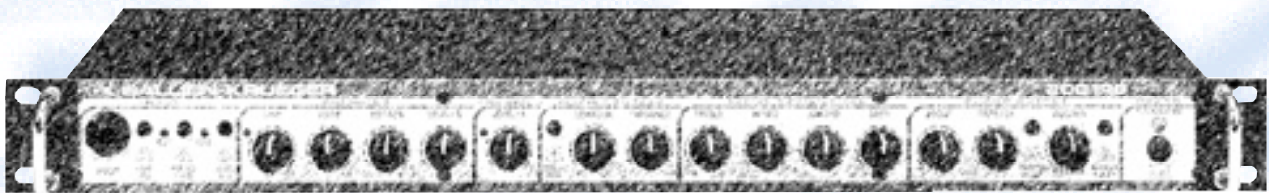





GK GALLIEN-KRUEGER

Table Of Contents

Introduction..... 3
Safety Information..... 5
Quick Start..... 6
Settings & Sounds..... 7
Sound Tips..... 9
Bridged Mode Operation..... 10
Bi-Amp and Normal Operation..... 11
Installation and Maintenance..... 12
Front Panel Controls..... 13
Rear Panel Controls..... 15
Tech Talk..... 17
Specifications..... 20

**All Features and specifications are subject to change without notice*
***This list is subject to change without notice.*

	CAUTION RISK OF ELECTRIC SHOCK DO NOT OPEN	
<p>CAUTION: TO REDUCE THE RISK OF ELECTRIC SHOCK, DO NOT REMOVE COVER (OR BACK). NO USER-SERVICEABLE PARTS INSIDE. REFER SERVICING TO QUALIFIED SERVICE PERSONNEL.</p>		
<p> The lightning flash with arrowhead symbol, within an equilateral triangle, is intended to alert the user to the presence of uninsulated "dangerous voltage" within the product's enclosure that may be of sufficient magnitude to constitute a risk of electric shock to persons.</p>	<p> The exclamation point within an equilateral triangle is intended to alert the user to the presence of important operating and maintenance (servicing) instructions in the literature accompanying the appliance.</p>	
<p>WARNING: TO REDUCE THE RISK OF FIRE OR ELECTRIC SHOCK, DO NOT EXPOSE THIS APPLIANCE TO RAIN OR MOISTURE.</p>		
<p>CAUTION: TO PREVENT ELECTRIC SHOCK, MATCH WIDE BLADE OF PLUG TO WIDE SLOT, FULLY INSERT. ATTENTION: POUR EVITER LES CHOCS ELECTRIQUES, INTRODUIRE LA LAME LA PLUS LARGE DE LA FICHE DANS LA BORNE CORRESPONDANTE DE LA PRISE ET POUSSER JUSQU'AU FOND.</p>		

Gallien-Krueger
 2240 Paragon Dr.
 San Jose, CA, 95131
 phone: 408-441-7970
 fax: 408-441-8085
 www.gallien-krueger.com

2001RB & 2001RBP

Congratulations

Your purchase of a new Gallien-Krueger 2001RB amplifier or 2001RBP preamplifier is surely the result of much careful consideration on your part. For our part, we at Gallien-Krueger are pleased that you chose us, and are determined that you will be a satisfied customer. In choosing a 2001RB unit, you now own an amplifier with many unique features, which will allow you to create your own distinct sound.

To get the most out of your new purchase please take a few minutes to read through this manual. If you are in a hurry, we suggest you at least read through the Quick Start and Safety Information sections before setting up your new rig. This will help get you started and give you a few quick tips, but is not a substitute for reading the rest of the manual.

Your amplifier should have come with the following items, please check the contents of the box to ensure that you have everything.

Included with your 2001RB Head:	
2001RB	1
Power Cord	1
4 Conductor Speakon Cable	2
RFB-III Footswitch	1
5-Pin DIN Cable	1
1 ft. 1/4" Stereo Cord	1
3.5MM Mono Cord	1
Owner's Manual	1
Warranty Card	1
Safety Instructions Sheet	1

Included with your 2001RBP:	
2001RBP	1
Power Cord	1
1 ft. 1/4" Stereo Cord	1
3.5MM Mono Cord	1
Owner's Manual	1
Warranty Card	1
Safety Instructions Sheet	1

If your 2001RB or RBP unit did not come with all the items listed, or if you encounter problems while setting up your new equipment, please contact your local dealer, or us as soon as possible at:

Gallien-Krueger, Inc.
2240 Paragon Drive
San Jose, CA 95131
phone: (408) 441-7970
fax: (408) 441-8085
Internet: www.gallien-krueger.com
Email: sales@gallien.com

We wish you a lifetime of good playing and remember to always have fun!

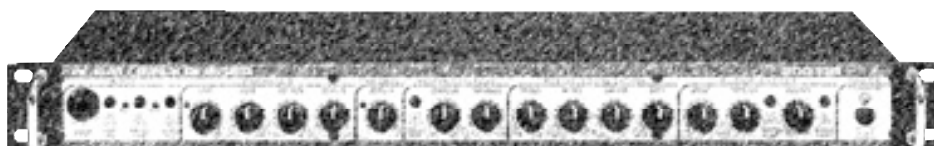

GK Philosophy

I have never seen the point in doing things the way others have done them. I also have not been very interested in following the latest fad. I am a Stanford educated engineer who worked his way through school as a musician. Like all musicians, I have lugged amplifiers up stairways and into car trunks, always wondering why these things had to be so heavy, bulky, and hard to handle.

As I am the principal innovator at GK, our products reflect my attitudes and life experiences. I don't model my designs after other manufacturer's products (as some of our competitors are proud of reciting).

Instead, I believe new and old problems are best solved with new solutions. Having taken our own path, GK products enjoy a unique, unmatched sound, allowing the artist using them every opportunity to make an original statement.

Having supported my products for over thirty years, I have learned from the story they tell. Gallien-Krueger is a reflection of that story, and has a commitment to support that legacy. Just as the products I created thirty years ago are still telling their story, the products we create today will be talking to us tomorrow.

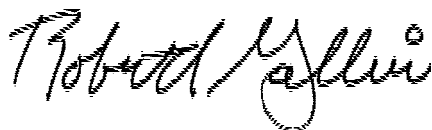

Robert Gallien

Safety Information

Verify Line Voltage and Amperage Before Use:

Your new 2001RB or RBP amp has been factory configured for use with:

- 120 Volt/60Hz 15 Amp circuit for USA & Canada.
- 230 Volt/50Hz 10 Amp circuit for Europe & Australia.
- 100 Volt/50Hz 15 Amp circuit for Japan.
- Proper AC circuit for all other countries.

Connecting the amplifier to a line with specifications other than indicated above can create a safety and fire hazard, and may damage the amplifier. If you have any questions about the voltage requirements for your specific model, or about the line voltage in your area, contact your dealer before plugging the unit into a wall outlet.

Verify AC Circuit Capacity Before Use:

The high power output of your amplifier may require heavy current draw under Full-Load conditions. To insure proper performance and avoid potential safety hazards, we recommend connection to line circuits with amperage specified "as above". Connecting multiple amplifiers to the same circuit, or connecting the amplifier to the same circuit used by other heavy-power devices, such as high-wattage lights, may cause circuit breakers to trip. It is always a good idea to avoid using any audio equipment on the same AC circuit as equipment with motors, such as air conditioners or refrigerators. This will lessen to possibility of power variation and electrical start-up noise affecting your sound.

Do Not Use Extension Cords:

To avoid safety hazards, use only the power cord supplied with your unit. If a replacement cord is used, make certain that it is of consistent quality and gauge as the original. We do not recommend using extension cords with this product. As with all electrical devices, do not run power cords under rugs or carpets or place heavy objects on them. Damaged power cords should be replaced immediately with cords meeting factory specifications.

Handle The AC Power Cord Gently:

When disconnecting the power cord from an AC outlet, always pull the plug, never pull the cord. If you do not intend to use the amplifier for a considerable length of time, disconnect the plug from the AC outlet.

Do Not Open The Amplifier Enclosure:

There are no user-serviceable components inside this product. Opening the amplifier enclosure may present a shock hazard, and modification to the product will void your warranty. If liquid enters the unit, or any metal object such as a paper clip, wire, or staple accidentally falls inside the enclosure, disconnect the unit from the AC power source immediately and consult an authorized service station.

Unpacking:

The carton and packing materials used in shipping your new amplifier were specially designed to cushion it from the shocks and vibration that occur during transport. We suggest that you save the carton and packing materials for use in shipping, in the event you move, or the amplifier needs repair.

Quick Start

The 2001RB is designed to be simple to operate. All controls have a well defined purpose and are well behaved. These directions will take you through the basics and give you a good start for setting up your sound.

1. Plug it in:

Set the power switch to Off and connect the supplied power cord, from the amplifier AC receptacle, to an AC power outlet of proper voltage and power rating (see safety information on page 5 for details).

2. Connect your cabinets:

Connect your speaker cabinet(s) to the LEFT or RIGHT 1/4" speaker jacks or Speakon outputs if using our RBH series cabinets. Be sure not to exceed the maximum recommended speaker loads below.

Maximum Recommended Speaker Loads:

Two 4 ohm or four 8 ohm cabinets per side in dual mono mode. One or two 8 ohm horns per side on the 50W amp. To connect other manufacturer's cabinets, use the LEFT or RIGHT 1/4" jack speaker outputs only.

If you are using an RBH Series cabinet, use the supplied 4 conductor Speakon cable to connect to the "Speakon" outputs on the rear panel of the amplifier. In addition, set the switch on the RBH cabinet to Bi-Amp.

For more information on Bridged mode and Bi-Amped mode, see pages 10-11.

Caution:

Do not connect the Speakon cables labeled "Bridge Mode" to the 2001RB. This may result in damage to the amplifier.

3. Initial front panel control settings:

Set all EQ controls and the Boost control to 12 o'clock. The Voicing Filters should be turned all the way down to get a flat response. Set the Level and Master Volumes at 0. If you have a five string bass, push the button marked String Bass in. Make sure the Level A/B button is out, so you are in the clean channel.

4. Plug in your bass:

Using an instrument cable, connect your bass to the Input jack and press the power switch on. If you have active tone controls on your bass, turn all of the controls to the middle or flat position and turn the volume all the way up. If you have conventional, passive tone controls, turn all tone and volume controls all the way up.

5. Level and Master Volume settings:

Set the Master Volume to 12 o'clock. Turn the Level-A volume up as you play. Try not to turn it past 1 o'clock if you have a bass with active tone controls unless you want an overdrive effect. If the yellow clip light turns on, press the -10db button in. If it is still on, try turning the volume down on your bass.

At this point:

You should be hearing your bass quite well. You can use the Volume and Woofer-Master to achieve a **comfortable sound level**. Remember: If you need more volume, turn up the Woofer-Master control first.

2001RB & 2001RBP

Settings and Sounds: 2001RB & 2001RBP

The 2001RB/RBP is versatile in its sound and tone. Below are a few suggested amp settings that can be used as starting points to define your own sound.

Note: the Gain/Overdrive settings will vary according to the output of your bass.

* Contour note:

At higher playing levels the contour should be set lower for mid-range clarity. To get 800RB voicing, the contour should be set to 0 or 10 only.

* Volume note:

Adjust volume before playing these recommended settings.

Tube Style Grunge: Both pickups recommended

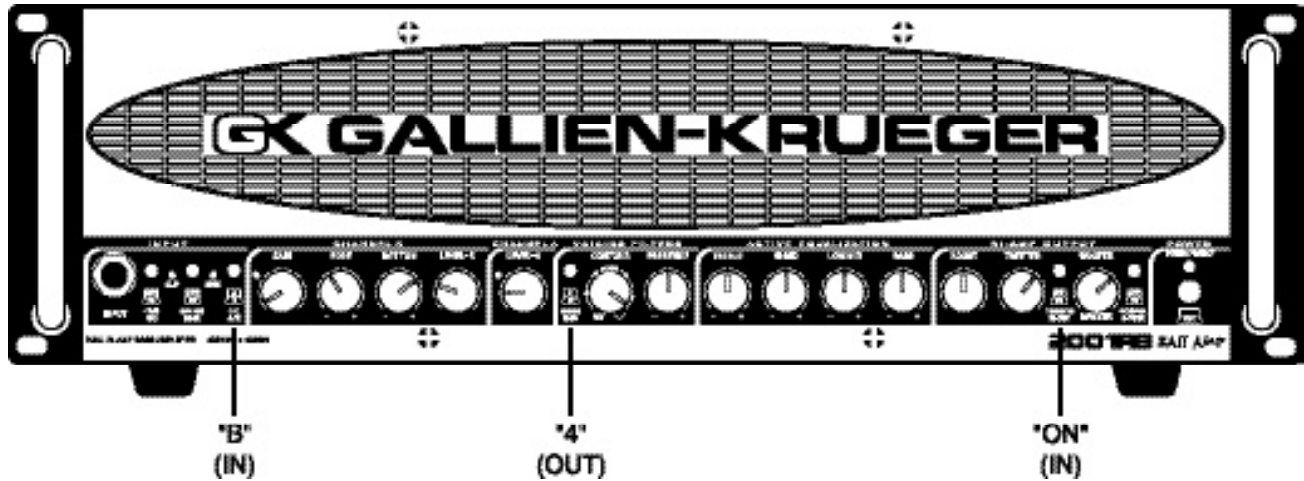

Insane Gain: Back pickup recommended

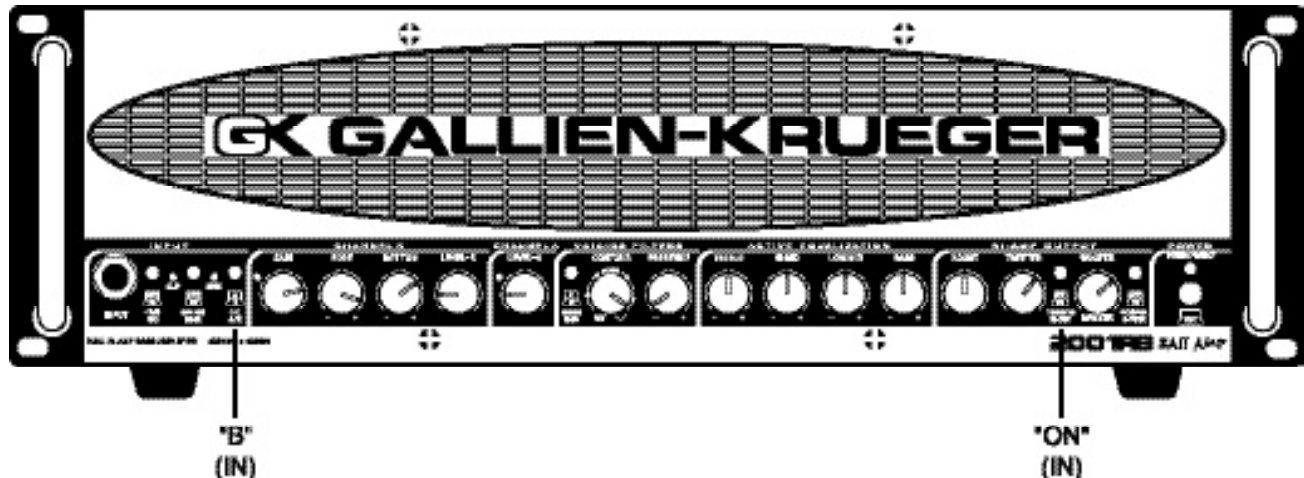

Deep Bass: Front pickup recommended

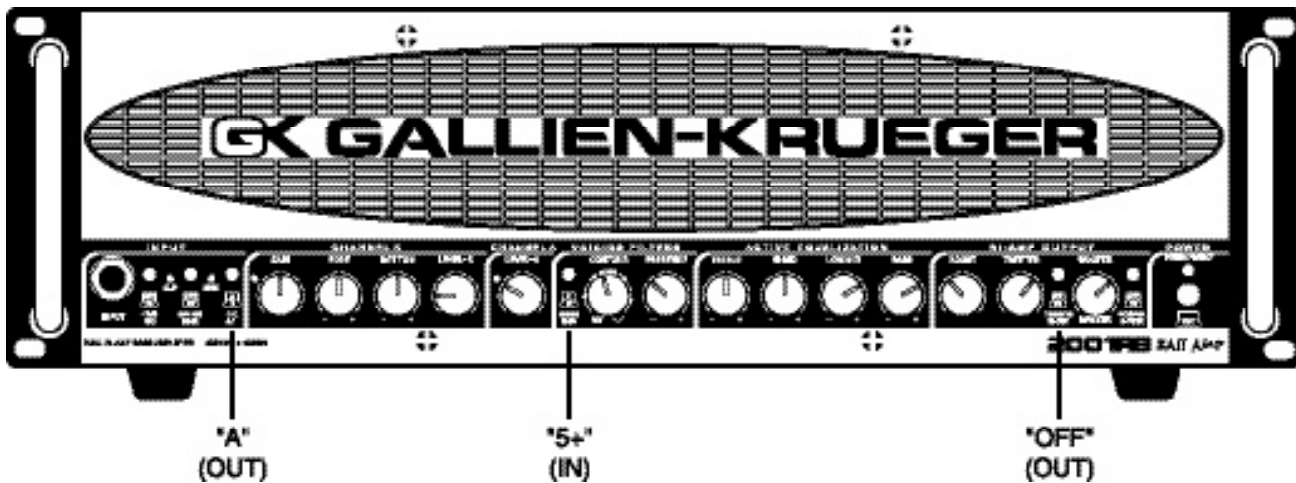

Slap: Both pickups recommended

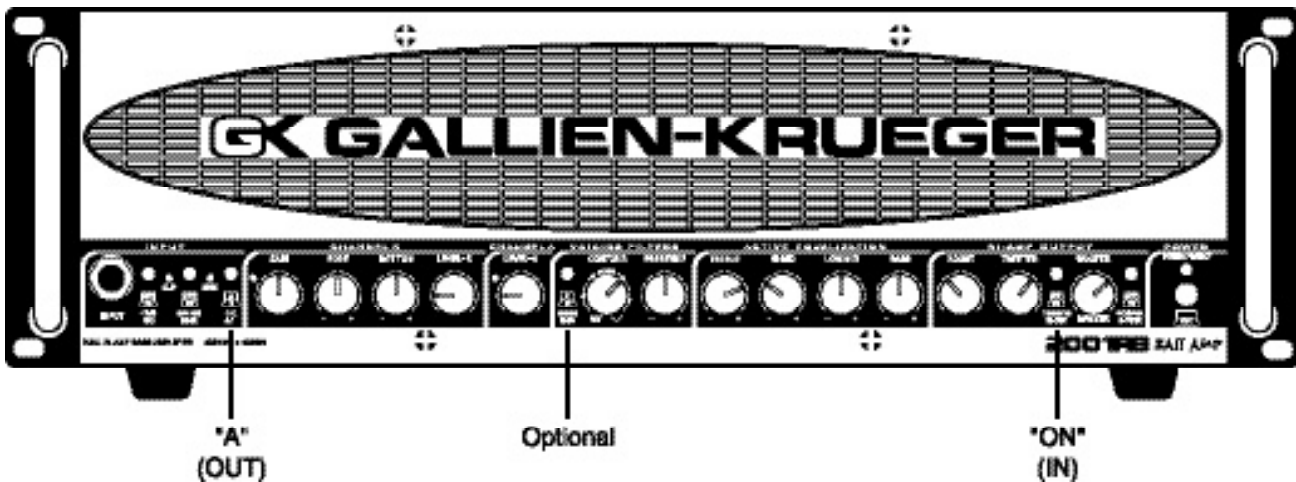

Sound Tips

The 2001RB has several unique features which, if used properly, will obtain that sound that's in the back of your head.

The Equalizer:

The Equalizer is used to fine tune your sound. When adjusting it, do it just a little at a time. These are active circuits, and small changes can make a big difference in your sound. With a little experimentation you will find that this equalizer is very easy to use, never sounds weird and provides you with a large variety of great sounds, unique to GK.

Contour:

Increasing the Contour level will scoop out mid-range frequencies while boosting the highs and lows. The sound, once again, is unique to GK and unavailable on any other Bass amp. Lower contour settings are recommended for midrange clarity at higher playing levels. For 800RB voicing, set the contour control either on 0 or 10 (Off, On on 800RB).

String Bass:

The way a Bass amp deals with the instrument low string is a critical part of its sound. In fact, a five string instrument requires an entirely different low end response than a four string instrument. No equalizer can make the necessary adjustments to accommodate both. However, the String Bass button on the 2001RB does just that. When it is out, the 2001RB is voiced like the 800RB. Push it in and the 2001RB is voiced for five string instruments. For some playing styles you may want it in, even with a four string instrument.

Boost/Master:

Turning up the Boost control, will add a little growl to your tone. This is an unmistakable GK trade mark sound, that you will grow to appreciate. Raising the Boost while lowering the Master will add more growl while keeping the sound level the same. Growl is actually a small amount of even order harmonic distortion, that sounds great through a woofer, but horrible through a horn (see Bi-Amp solution below). For most playing situations, the Master is set between 12 & 3 o'clock. The cleanest sound is obtained by setting the Master above 12 o'clock, and going above 3 o'clock for maximum power situations.

Direct Out:

The 2001RB provides a low noise, high quality balanced direct out for connection to PA and recording consoles. With the Pre/Post EQ switch set to "Pre" (Out), the direct output signal is fed directly from our low noise, high headroom, FET input stage providing a low noise output superior to external direct boxes and impedance transformers. In addition, this output is calibrated for 1.0V (0 dBV) output and can be adjusted to unity gain (instrument level) by adjusting the Level control to -15 dB (U). With the switch in the Pre position, the Direct Output signal is only effected by the Level, -10dB Pad, and Tuning Mute controls. This allows you to adjust your tone and volume on stage without changing the Direct Output signal level and confusing your sound man.

Changing the Pre/Post EQ switch to "Post" (In), sends the "GK sound" and preamp response to the Direct Out jack. This gives you complete control over the Direct Out's tone and volume. In addition, a Ground (Gnd) Lift switch is included to remove hum and buzz when connecting to equipment powered by a different ground system.

Bridged Mode Operation

Note:

To operate the 2001RB in bridge mode, you must use the L/BR Speakon outputs only. Using the Left channel, 1/4" outputs will not work, since the ground for those jacks are internally disconnected when in bridge mode. Using any of the Right channel 1/4" or Speakon outputs is not recommended as this will result in a malfunction, or undesired operation of the amplifier.

1. Make sure nothing is connected to any of the Right channel outputs.
2. Slide the Bridge Mode switch on the back of the amp from Dual mono, to Bridge.
3. The "Right Level" knob on the back of the amp should be turned all the way up (clockwise) or power output will be compromised.

Since Bridge Mode operation is only available through the Speakon outputs, the type of Speakon cable you need depends on the brand of cabinets that you are using. When using our RBH Series cabinets, using our four-conductor Speakon to Speakon Biamp cable will allow Bridged Mode and Bi-amp operation simultaneously. Since the 50W horn amps are always active, this allows you to deliver 1080W to your cabinet and 50W to the horn. When using other brand name cabinets a two-conductor Speakon cable will be needed but the Bi-amp feature will not work. It is very important, that these two-conductor Speakon cables are wired correctly. The 1+ pin connects to the tip of the 1/4" plug and the 1- pin connects to the shield.

DO NOT USE "BRIDGED MODE" SPEAKON CABLES WITH THIS AMP!!!

These are wired 1+ and 2+ which would connect the horn and woofer amps together. This could cause damage to your cabinet and/or the amplifier.

2001RB setup for Bridged Bi-Amp Operation:

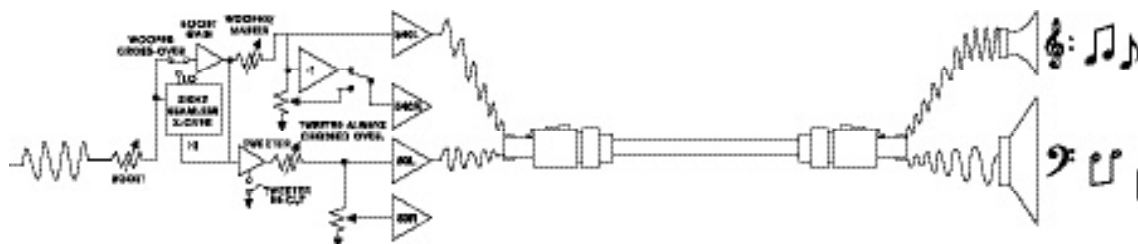

2001RB setup for Bridged Normal Operation:

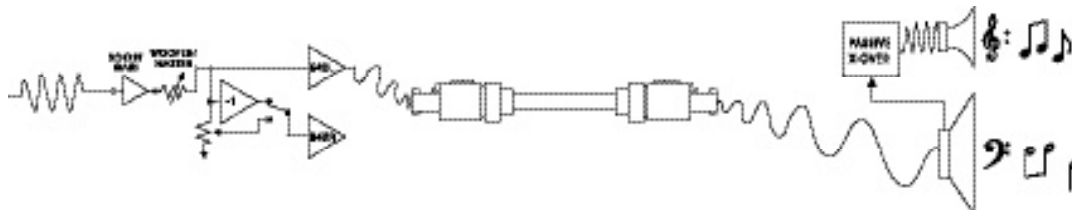

Bi-Amp and Normal Operation

The 2001RB's unique design allows for easy setup into Bi-Amp or Normal configurations. The operational mode is configured by how you connect your speaker cabinets. In addition, you have the option of driving one cabinet in Bi-Amp and one with Normal operation.

2001RB setup for Bi-Amp Operation:

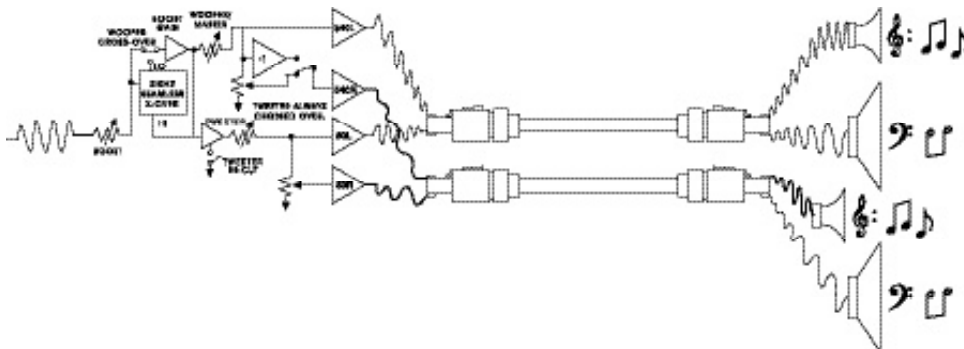

2001RB setup for Normal Operation:

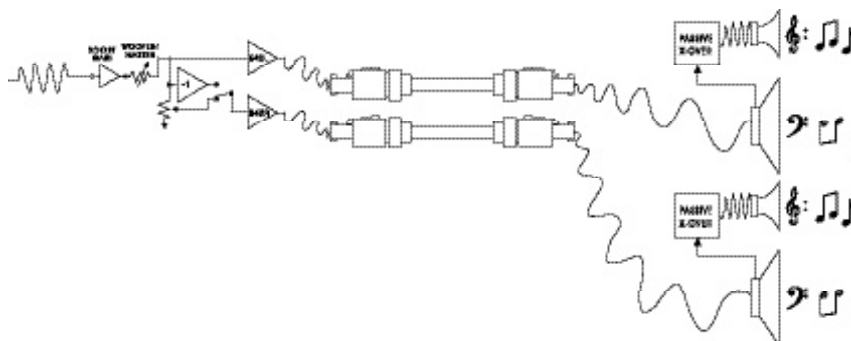

2001RB setup for Bi-Amp Operation:

The Bi-Amp feature of the 2001RB is automatically engaged when you connect an RBH series cabinet (with switch on the cabinet set to Bi-Amp) to the 2001RB with the supplied 4 conductor Speakon cable. This setup gives the 2001RB complete control of the tweeter and woofer signals sent to your rig. Now you can push the woofers to the max., while the tweeter remains clean, crisp and free of clipping distortion. In addition, a smooth tight tone is easily dialed in by adjusting the Tweeter and Woofer Master controls on the 2001RB front panel. Note: In the Bi-Amp configuration, we recommend starting with the Woofer X-Over and Tweeter Hi-Cut controls in.

GK Speakon Cable
1+ 540W Amp +
1- 540W Amp -
2+ 50W Amp +
2- 50W Amp -

GK RBH Series Cabinet
410RBH, 210RBH,
115RBH
Set to Bi-Amp mode.

2001RB setup for Normal Operation:

The 2001RB series amplifier is configured for normal operation when you are connecting to any cabinet with a 2 conductor Speakon cable, 1/4" to 1/4" speaker cable or 1/4" to banana plug speaker cable. In this setup, the speaker cabinet is driven by the 540W amp and the 50W tweeter amplifier is not used. If you are using RBH series cabinets, the volume of the tweeter (relative to the woofer's volume) can be adjusted using the Horn Level control of the cabinet's internal crossover.

GK Speakon Cable
1+ 540W Amp +
1- 540W Amp -
1/4" Speaker Cable
Tip 540W Amp +
Shield 540W Amp -

GK RBH Series Cabinet
410RBH, 210RBH, 115RBH
Set to Full Range mode.
Any brand name cabinet with
appropriate impedance and
power rating.

Installation and Maintenance

Installation:

- To insure proper operation and to avoid potential safety hazards, place the unit on a firm, level surface. When installing the unit in a rack, be sure the mounting hardware can support the amplifier's weight. To save space in your rack, the 2001RB's feet can be removed using a Philips head screwdriver.
- Make certain that proper space is provided for ventilation. Never block the fan vent holes in the rear or front of the amplifier. If the amplifier will be installed in a rack or other enclosed area, make sure that there is sufficient air movement within the enclosure to allow proper cooling. Consult your dealer for more information.
- Avoid installation in extremely hot or cold locations, and areas that are exposed to direct sunlight, or near heating equipment.
- Avoid moist or humid locations.
- Remember, power amplifiers generate heat. The heat sink fins and ventilation slots that form part of the enclosure are specially designed to remove this heat. Placing other electronic equipment near these heat-dissipation systems may possibly affect the long-term reliability of both your amplifier and the other equipment.

Moving the Unit:

Before moving the unit, be certain to disconnect any interconnection cords with other components, and make sure that you disconnect the unit from the AC outlet.

Cleaning:

When the unit gets dirty, clean only with a dry cloth. Never use benzene, thinner, alcohol, or other volatile cleaning agents. Do not use abrasive cleaners, as they may damage the finish of metal parts. Avoid spraying insecticides near the unit.

Maintenance:

Your new amplifier is rugged. It was built to give you years of trouble-free operation, if it is operated in accordance with the instructions contained in this manual. The only maintenance required is cleaning. If you are going to move your amplifier around frequently, we recommend a road case to protect it from scratches and road wear.

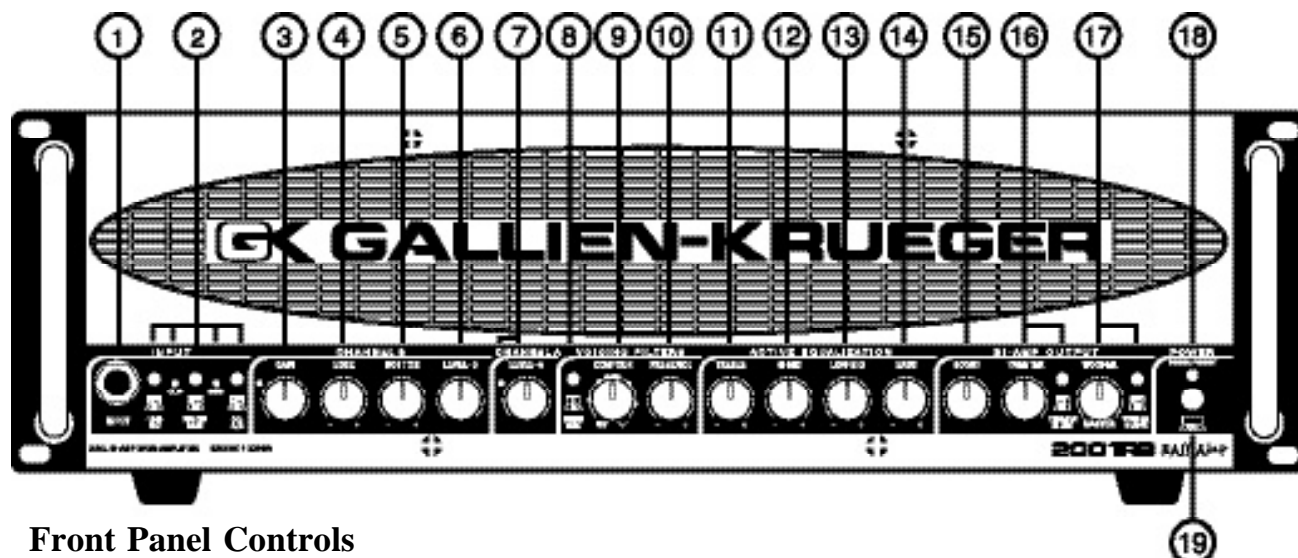

Front Panel Controls

INPUT:

1. Input:

A standard ¼" input jack to plug in active or passive basses using a shielded cord.

2. -10dB PAD:

Input attenuator button. The button is generally left out, except in rare cases when the clip LED flashes. This switch should be pressed if the CLIP LED stays on continuously. It may be necessary to "pad" the input if you are using a bass with active electronics or very high output.

Clip LED:

LED lights yellow when the input stage is being over-driven. If -10dB PAD (2) is pressed and clip LED still stays lit, turn down the volume on your bass.

Tuning Mute Button:

Set this switch to "ON" (In) when tuning up. This switch mutes all outputs from the amplifier (speaker, direct, and balanced outs) so you can tune up without sending signal to the audience, speakers, or the P.A. system. Tuning Mute can be footswitch controlled by using the GK "RFB-III" footswitch, which will leave both hands free to tune your instrument. To control Tuning Mute by footswitch, the "Tuning Mute" switch on the 2001RB must be in the "OFF" (OUT) position.

Mute LED:

LED turns on when "Tuning Mute" is switched to the "ON" position or when activated through the footswitch.

Channel A/B:

Switches between the Normal and Overdrive channels. When in the "B" (In) position, the switch activates "Channel B" (Overdrive). "A" (Out) position activates "Channel A" (Clean). In order to use the footswitch to control the channel switching, "Channel A/B" should be in the "A" (Out) position on the 2001RB.

CHANNEL B:

Channel B LED:

LED turns on when in the "Channel B" (Overdrive) mode.

3. Gain:

Controls the amount of overdrive in the "B" channel. At low settings it provides a smooth distorted sound. At high levels it will provide full saturation with long sustain.

4. Edge:

Treble control for the Overdrive channel.

5. Bottom:

Bass control for the Overdrive channel.

6. Level-B:

Adjusts the output level of the Overdrive channel.

CHANNEL A:

Channel A LED:

LED turns on when in the "Channel A" (Clean) mode.

7. Level-A:

Sets preamp gain after the input stage. It is used in conjunction with the input pad, to optimize the amplifier's headroom.

VOICING FILTERS:

8. 4/5 String Bass:

Switching this button to the "ON" position, voices the pre-amp for basses with "B" tuning (5 string bass). Leaving it in the "OUT" position will voice the amp like the 800RB, for a four string bass.

9. Contour:

Drops the mid-range frequencies while boosting lows & highs.

10. Presence:

This adds edge and definition to higher frequencies.

ACTIVE EQUALIZATION:

11. Treble:

Boost and cut at 7kHz±14dB shelving type. Add or remove edge and definition.

12. High Mid:

Boost and cut at 1 kHz +6dB -10dB, “Q Optimized,” band pass type. Works on lower string harmonics, and effects the punch of your sound.

13. Low Mid:

Boost and cut at 250Hz +6dB -10dB, “Q Optimized,” band pass type. Works on the main body of your sound.

14. Bass:

Boost and cut at 60Hz ±10dB, shelving type. Controls low end push.

Outputs:

BI-AMP OUTPUT:

15. Boost:

A post EQ gain stage using G.I.V.E. technology which adds “growl” as it is turned up.

16. Tweeter:

Master volume control for the tweeter (50W) amp.

Tweeter Hi-Cut:

Cuts frequencies above 10kHz, producing a more “cone-like” (less metallic/harsh) sound from the tweeter.

17. Woofer:

Master volume control for the woofer (Main) amp.

Woofer X-Over:

Press this button to engage the electronic crossover for the woofer. This cuts frequencies above 5kHz (Rolls off the highs).

POWER:

18. Power/Protect LED:

The LED flashes at turn-on for five seconds while the amp powers up. The LED turns blue when the amp is ready to play. Should the amp experience a fault (over heat, over current) the amp will mute and this LED will flash orange until the condition is corrected. This LED turns green when the power switch is turned off.

Standby Mode:

When using two or more 2001RBs in a master/slave configuration, the power LED on the slave amps will be orange. The LEDs will turn blue when the master amp is turned on.

19. Power Switch:

Turns the amplifier on or off. Should a problem occur during operation press this switch out first. The power LED should green at this point or flashing orange if a fault is present.

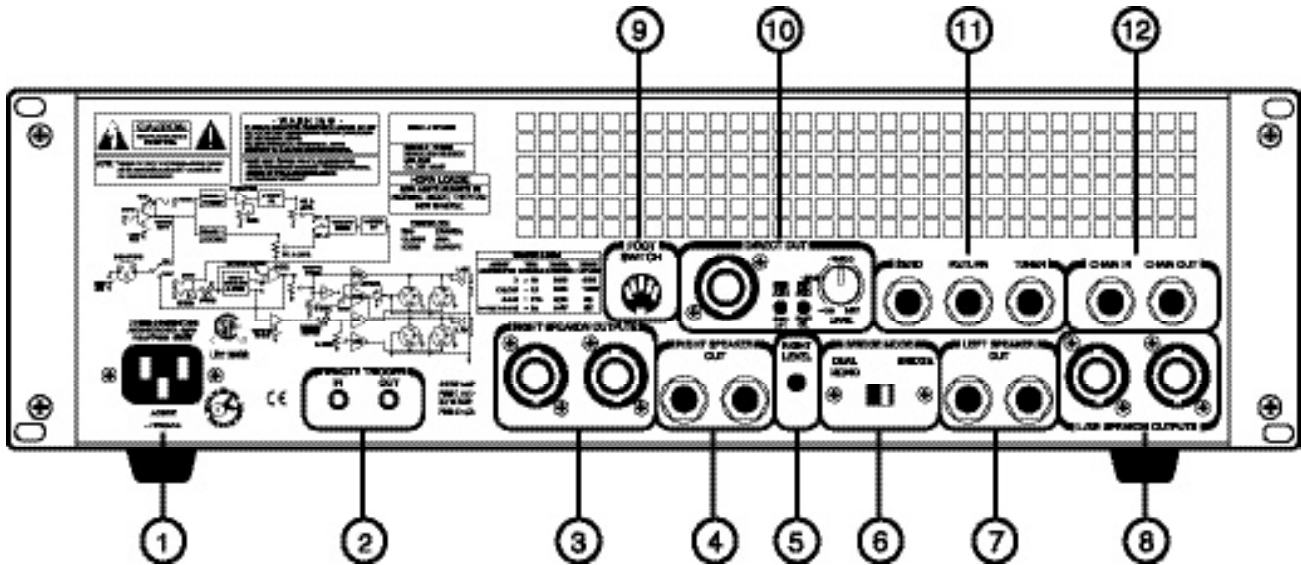

Rear Panel Controls

1. AC Receptacle:

The power cord is detachable and plugs in here.

2. Remote Trigger:

This feature is used when using multiple 2001RB's as "master" and "slave" units. It allows you to turn on all amplifiers at the same time, when the "master" unit is powered on.

In:

Accepts the +12VDC signal from the "master" 2001RB's Trigger Out jack to activate or turn on, the "slave" 2001RBs when in standby mode.

Out:

Provides +12VDC as a trigger output to remotely turn on a "slave" 2001RB.

3. Right "Speakon" Outputs:

Enables BI-AMP operation by connecting a GK-RBH Series cabinet with the provided 4 conductor Speakon cable. This connects the 50W amplifier allowing the Tweeter control on the front panel to control the signal going to the horn. See Bi-Amp and Normal Operation on page 7 for more information.

4. Right Speaker Out:

540W power amp output for Full-Range operation only. They deliver 540 watts into 2 Ohms or 360 watts into 4 Ohms. Lower impedances should not be used.

5. Right Level:

This adjusts the output level of the right channel only in dual-mono mode.

6. Bridge Mode:

This allows one to switch from Dual/Mono to Bridge mode.

7. Left Speaker Out:

540W power amp output for Full-Range operation only. They deliver 540 watts into 2 Ohms or 360watts into 4 Ohms. Lower impedances should not be used.

8. Left/Bridged "Speakon" Outputs:

Enables BI-AMP operation by connecting a GK-RBH Series cabinet with the provided 4 conductor Speakon cable. This connects the 50W amplifier allowing the Tweeter control on the front panel to control the signal going to the horn. See Bi-Amp and Normal Operation on page 7 for more information. These "Speakon" outputs also enable "bridged mode" operation. When in bridged mode, the 2001RB will be in a simultaneous bridged/Bi-amp mode, since the 50W horn amplifiers are always active (in the clean channel only) unless you choose to use the "horn mute" feature, via the RFB-III footswitch.

DO NOT CONNECT ANYTHING TO THE RIGHT CHANNEL OUTPUTS WHEN IN BRIDGED MODE!!

DO NOT USE "BRIDGE MODE" CABLES WITH THIS AMPLIFIER, AS THIS COULD RESULT IN A MALFUNCTION AND/OR DAMAGE TO THE AMPLIFIER.

9. Footswitch:

Provides a means to hook-up the RFB-III, three button footswitch to your amplifier, with a standard 5 pin DIN (MIDI) cable. The RFB-III allows remote Channel Switching (Level A or Level B), Horn Mute (when in the clean channel) and Tuning Mute.

10. Direct Out:

Gnd/Lift:

This switch disconnects the ground on the balanced, XLR output to eliminate hum and buzz when connecting to equipment that is running on a different ground system.

Pre/Post EQ:

Selects the direct out signal before or after the EQ.

Direct Level Out:

Electronically balanced adjustable output, that you can run to your P.A. system.

11. Send, Return & Tuner:

Send:

Line level output that is post EQ and pre Boost. Used when sending a full range mono signal to an external device (effects, processors, etc.)

Return:

Accepts line level return from external effects that are connected in a "series loop".

Tuner:

Output comes directly off the input stage and can be patched to a tuner with a shielded patch cord. This output is unaffected by the Tuning Mute feature.

12. Chain In & Chain Out :

This "daisy chain" feature is used when multiple 2001RBs are used as "master" and "slave" units. Both jacks are stereo, where the "tip" is the "woofer output" and the "ring" is the "horn output".

Chain in:

When the master amp's "Chain out" signal is input to the slave amp's "Chain in", the slave amp's preamp/ tone control section is bypassed completely, and will serve as a straight power amp only.

Chain out:

This output is used to "daisy chain" or connect other slave amps to the master amp. The signal going into the slave amp's "Chain in" is the same signal coming out of the "Chain out". This eliminates the need for special Y-adapters.

NOTE:

When using the "Daisy-Chain" feature, the stereo cable cord should be one foot in length or as short as possible to reduce hum/noise.

Maximum Recommended Loads:

Two 4 Ohm or four 8 Ohm cabinets per side, dual mono mode. One 4 Ohm or two 8 Ohm cabinets in bridged mode. One or two 8 Ohm horns on the 50W Amps.

CAUTION:

UNDER NO CIRCUMSTANCES SHOULD THE 540W AMP AND THE 50W AMP BE CONNECTED TO EACH OTHER OR BE CONNECTED TO THE SAME SPEAKER !!!

Tech Talk

Characteristics of the 2001RB:

The 2001RB is a flexible, state-of-the-art Bass Amplifier, designed to deliver maximum performance, and be simple to operate. This is accomplished through a few, very important features:

- Extremely high current power supply and power amp circuitry, gets the sound out of your head.
- Bi-Amp sound, two power amps, 540 Watts for the woofer (1080W bridged), and 50 Watts for the horn.
- Electronic crossover, seamless two-way sound.
- Four, Bass specific bands of active equalization for precise tone control.
- Three voicing filters for shaping and customizing your sound.
- Balanced direct output with level control eliminates need for a direct box.
- Continuously variable fan cooling.
- Designed and Built in the U.S. for years of reliability and quality service.

High Current Output & Bass Response:

When a power amplifier is pushing several speaker cones, and a high-power transient like a string slap comes along, the amp has to tap into a large power reserve to maintain cone control. It's kind of like grabbing a swing at the bottom of its travel and trying to push it the other way - it could knock you over. If the amplifier doesn't have this ability, the sound is unresponsive and less out front. The amp loses its punch and feel at higher playing levels. Instead of responding to your every command, the amplifier simply cuts those transients off, leaving you with the feeling that something is missing in your sound.

Since most amplifiers have limited output current capacity, they need "current limiting circuits" to protect against self-destruction. High-power transients trigger these circuits, which rob the amplifier of its ability to control speaker cones. This creates a mushy, unresponsive feel to your sound. The 2001RB has extremely high current capacity, so it doesn't need current limiting circuits for over-load protec-

There is nothing in the 2001RB power amp to come between you and your sound except faithful, raw power.

Bi-Amp Sound:

Bass players have always liked the growl they get from slight overdrive. In GK amps this comes partly from the boost circuits and partly from the power amp. The problem is that growl, sounds great through woofers, and horrible through horns. In the typical full range system with a passive crossover, there is no way to get growl and keep the definition that the horn provides. The horn always has to be turned down. In a Bi-Amp system like the 2001RB, the woofer and the horn, each have their own power amp, allowing us to get growl in the woofer only, while keeping the horn sound crystal clear. Now you can over-drive the woofer as much as you want, and leave the horn all the way up, keeping the definition it brings to your sound. Running the 2001RB in Bi-Amp mode through a GK-RBH cabinet, for the first time allows full access to the benefits of Bi-Amp sound. This is the reason the 2001RB is a Bi-Amp, and it is the reason you will be able to explore an entirely new territory of Bass sound.

Electronic Crossover:

Bi-Amp systems allow the crossover to be electronic and therefore, have much higher quality than passive crossovers. A crossover separates the sound into two parts (high and low frequency). The highs are sent to the horn or high frequency cabinet and the lows are sent to the woofer. In an ideal system, adding the highs and the lows back together would recover the original signal. Most passive Bass systems have very poor crossovers, resulting in severe signal corruption. When these signals are added back together (as in your ear), they have very little in common with the original signal. The 2001RB uses a Constant Voltage crossover which results in very little signal corruption. In fact, when the high and low signals are added back together, the result is extremely close to the original. This makes a two-way system sound more seamless, and less artificial. We have also included a Tweeter Hi-Cut switch in the crossover, which rolls the tweeter off above 10kHz giving it a less glassy, more cone like sound.

Tech Talk

Equalization:

The sound you want is in your head, but you just can't get it. You think it's you, your bass or maybe your amp. Yes, your amp. Standard tone controls and graphic equalizers don't get it. Sure, they give you plenty of variation, but they don't provide what the instrument really needs. The fact is, graphic equalizers are intended for room equalization, and are only put in bass amps because it's a no-brainer for the designer. The equalization in Gallien-Krueger amplifiers reflects 30 years of continuous development and refinement. The GK equalizer is unique to the industry, it's not just a normal four band equalizer, each section is a special circuit optimized to perform a Bass specific job in its range of operation. These sections are wired in Series, so they add to one another creating a tremendously flexible equalizer, that doesn't sound weird at any setting. You actually might even get to hear that sound in your head.

Voicing Filters:

Voicing filters are used to completely re-voice the amplifier. In the case of the Contour and String Bass controls, the effect is dramatic.

The Contour control tunes between two different shaping circuits, with greatly different response. With the control all the way up, the low end is slightly boosted, the mids are dropped and the high end is pushed up. This is a response contour not available with a normal equalizer, and is only found in GK amplifiers.

The way a Bass amp deals with the instrument low string is a critical part of it's sound. In fact, a five string instrument requires an entirely different low end response than a four string instrument. No equalizer can make the necessary adjustments to accommodate both, however the String Bass button on the 2001RB does just that. When it is out, the 2001RB is voiced like the 800RB. Push it in and the 2001RB is voiced for five string instruments. For some playing styles you may want it in, even with a four string instrument...at least now, you have a choice!

“G.I.V.E.” Technology:

As in all GK pre-amps, the 2001RB pre-amp incorporates what we call G.I.V.E (Gate Induced Valve Effect)

Technology. We use field effect devices with the gate biased in a way that emphasizes the optimum harmonic content of the signal. Working in concert with our unique Four Band Active Equalizer, and three stage Voicing Filter Section, G.I.V.E. technology produces a consistently pleasing bass tone.

Cool Running = Reliability:

The 2001RB uses a “dual rail power supply” that generates about half the heat of conventional amplifiers. Low output signals run off a low voltage supply, and high level signals run off a high voltage supply. This keeps the amp running a lot cooler and makes it much more reliable. To cool the amp when its being driven hard, we've designed a temperature sensitive fan cooling system. When the amp is under a light load, the fan is off or running at a low speed, reducing fan noise. As the amp works harder, the fan speed increases to keep everything cool.

Smart Protection Circuitry:

The 2001RB's protection circuitry constantly monitors for unsafe operating conditions such as short circuits, mis-wired speaker cables, blown speakers, improper ventilation and incorrect speaker configurations. In addition, protection is provided during power up/down. If the 2001RB senses any unsafe operating conditions, the output signal is immediately muted and the power light changes from Blue to flashing orange. The amplifier will remain muted until the fault is removed. If the protection circuit activates while playing, turn the amplifier off and check the amplifier speaker output connections. Be sure that you are not exceeding the maximum recommend load described in this manual. Also, make sure that you have connected the amplifier to your speakers as described in Bi-Amp and Normal Operation on page 7. If the problem persists, contact GK directly for advice.

Low Noise Operation:

The 2001RB uses a high gain, high headroom, low noise input stage. It has such a large dynamic range (60v p-p) that very few instruments can overdrive it. Even most basses with “active” electronics do not need the input attenuator to be set. The benefit to you is less hiss from your horn, and over all, much less noise.

Tech Talk

Speakon Cables:

To make use of the 2001RB's Bi-Amp and Bridge mode features you will need to use the four conductor Speakon cable (provided with the 2001RB head) to connect to a GK RBH Series cabinet. This specially designed cable carries the signals for both amplifiers (540W Woofer Amps and 50W Tweeter Amps) to the speaker cabinet. Below is a table describing the Speakon cable connections to the 2001RB head.

Speakon Pin #	Signal	Wire/Color
1+	540W Woofer Amp +	White
1-	540W Woofer Amp -	Black
2+	50W Tweeter Amp +	Red
2-	50W Tweeter Amp -	Green

To obtain an additional 4 conductor Speakon cable for use with the 2001RB please contact your local dealer or contact GK directly.

In Closing:

You should now have a thorough understanding of how your new 2001RB amplifier works and what advantages it can offer you in getting "your" sound. We thank you for reading the Owner's Manual and wish you the best of times! Please send us your comments via www.gallien-krueger.com or email us at sales@gallien.com.

Block Diagram

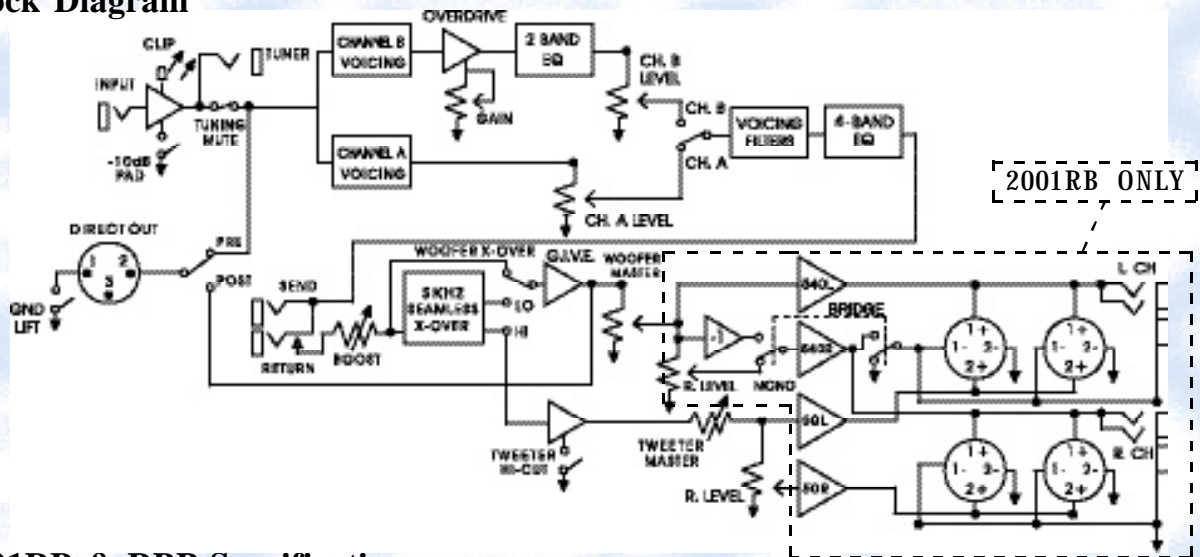

2001RB & RBP Specifications:

2001RB ONLY:

Output Power:	
Woofers Amplifier	2 x 540W @ 2 Ohms
Both Ch. Driven	2 x 360W @ 4 Ohms
	240W @ 8 Ohms
	1080W bridged @4 Ohms
	650W bridged @8 Ohms
Horn Amplifier	50W @ 8 Ohms
	75W @ 4 Ohms

Input Section:

Maximum Input Level	0.6V Rms
With -10dB pad	1.6V Rms
Input Impedance	1M Ohm
Send output impedance	220 Ohm
Return input impedance	50k Ohm
Tuner Output Impedance	10k Ohm
Direct Output Impedance	500 Ohms

Equalizer:

Bass	±10db @ 60Hz
Lo-Mid	+6db/-10db @ 250Hz
Hi-Mid	+6db/-10db @ 1kHz
Treble	±14db @ 7kHz

Voicing Filters:

String Bass Button	+11db@20Hz
Contour	+2db@50Hz / -10db@500Hz / +3db@7kHz

Presence +9db@10kHz

Crossover Triple pole constant voltage crossover at 5kHz

Noise -90db referenced to 500W, "A" weighted

Cooling: Continuously Variable-Speed Fan

Amplifier Protection:
Full short circuit, thermal, & RF protection.
Stable into reactive and mismatched loads.
Five second muted warm-up.

Dimensions (HxWxD):

2001RB:	5.25" x 19" x 12"
	(3Rack Spaces)
2001RBP:	1.65" x 19" x 6"
	(1Rack Spaces)

Weight:

2001RB:	40 lbs
2001RBP:	8 lbs

Power Requirements:

	2001RB:	2001RBP:
U.S.A./Canada	120V/60Hz	120V/60Hz
(full power)	1600W	4W
(average power)	500W	
Europe	230V/50Hz	230V/50Hz
(full power)	1600W	4W
(average power)	500W	
Japan	100V/50Hz	100V/50Hz
(full power)	1600W	4W
(average power)	500W	

GK GALLIEN-KRUEGER