

1. Introduction

Module **A-166** is a **dual logic device** to combine digital control signals.

It contains **2 identical units** with **3 inputs** for each unit. The logical states of the inputs ("1" = high / "0" = low) are **linked** together in 3 ways: **AND, OR, EXOR** (exclusive OR).

The three functions are available **simultaneously** at **three outputs with LED display** of the output states.

Additionally **two inverters** are available to obtain the **inverted functions NAND, NOR and NEXOR**.

The **input sockets** of each triple unit are **"normalized"**, i.e. the switched contact of socket 2 is connected to input 1 and the switched contact of socket 3 is connected to input 2.

A **typical application** is the combination of digital signals of the A-100 (gates, clocks, triggers), e.g. to obtain **"gated" clocks** or **rhythmic clock patterns**.

2. LOGIC - Overview

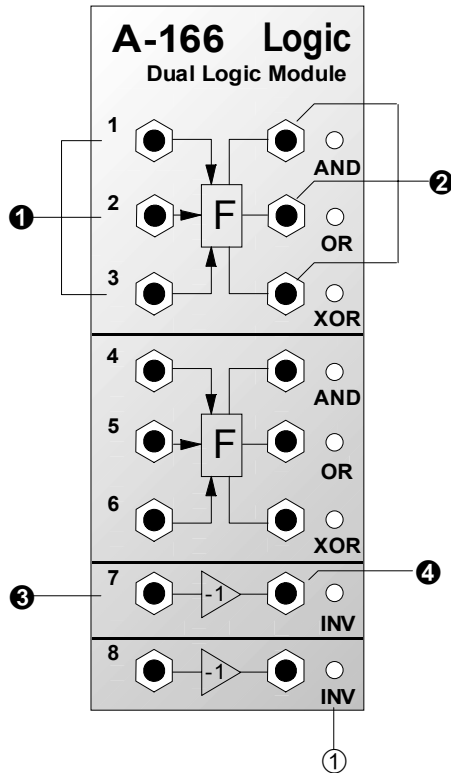

Controls:

- ① LED : Display of the logical state for the corresponding output

In / Outputs:

- ① (Input) 1, 2, 3 : Inputs for the AND, OR, and XOR function
- ② (Output) AND,OR,XOR: Output of the corresponding function
- ③ (Input): Inverter input
- ④ (Output) INV: Inverter output

3. Controls

① LEDs

The LEDs display the logical state of the corresponding output (on = logical "1" / high, off = logical "0" / low).

4. In / Outputs

① Input 1 • Input 2 • Input 3

The sockets Input 1, 2 and 3 are the **common inputs** of the logical functions AND, OR and XOR. The digital control signals that have to be linked (e.g. gate, clock) are connected to these sockets.

If "normal" analog voltages are used as inputs any voltage less than about +1 V corresponds to a logical "0" (low); voltages above about +2 V are taken as logical "1" (high).

The sockets of each triple unit are "**normalized**", i.e. the switched contact of socket 2 is connected to input 1 and the switched contact of socket 3 is connected to input 2. Provided that no plug is inserted into socket 1 resp. socket 2 the socket is connected to the input above it.

Inputs			Outputs					
1	2	3	AND	OR	XOR	NAND	NOR	NEXOR
0	0	0	0	0	0	1	1	1
0	0	1	0	1	1	1	0	0
0	1	0	0	1	1	1	0	0
0	1	1	0	1	1	1	0	0
1	0	0	0	1	1	1	0	0
1	0	1	0	1	1	1	0	0
1	1	0	0	1	1	1	0	0
1	1	1	1	1	0	0	0	1

Table 1: Logical functions of the A-166

This simplifies the usage of the module if only 2 signals have to be combined. Otherwise the third input would have to be fed with the neutral level for the desired logical function. As the logical functions have different neutral levels this would cause problems. E.g. the logic functions AND and OR have different neutral input levels: "1" is the neutral state for AND, "0" is the neutral state for OR. In case of a fixed input level for the unused input one of the two functions (AND or OR) would work no longer.

② AND • OR • XOR

These are the output sockets for the three logical functions. The output of each state depends upon the on the three inputs (refer to table 1). A logical “0” corresponds to about 0V (in every case less than +1V), “1” to +12V (at least +10V).

③ Input

Socket ③ is the **input of the inverter**.

④ INV Output

At the **inverter output** ④ the inverted signal of the inverter input ③ is available. A logical “0” at the input is converted to “1” and vice versa.

By means of the inverters it is possible to invert a signal before it is fed into one of the two logical units. In addition the inverse logical functions **NAND** (negated AND), **NOR** (negated OR) and **NEXOR** (negated exclusive OR) can be realized (see table 1, right columns).

The voltage ranges that correspond to “0/low” and “1/high” state for the inputs and outputs of the inverters are the same as for the logical functions.

5. User Examples

The A-166 can be used to combine all kind of digital signals of the A-100 (i.e. clock, gate or trigger signals).

Therefore manifold applications like gated clocks or the creation of complex rhythmical structures are possible. A typical example is the combination of signals coming from a clock source (e.g. clock output of A-190, rectangle output of a LFO), clock divider (A-160), clock sequencer (A-161) or analog/trigger sequencer (A-155) with each other or with other digital signals like gate or trigger e.g. from the MIDI interface A-190, Theremin A-178, Trautonium/Ribbon Controller A-198, Trigger delay A-162, VC decay/gate A-142, VC divider A-163 or external input A-119.

A typical example shows the patch in fig. 1. The outputs “1”, “5” and “7” of the clock sequencer A-161 are “added” with the A-166 (OR function) and this signal is “gated” with the clock output “8” of the clock divider A-160 (AND function).

Likewise it is possible to derive a gate signal from an audio signal using the external input/envelope follower A-119 and combine this with other clock, gate or trigger signals.

Fig. 1: Patch for generation of rhythmic clock signals

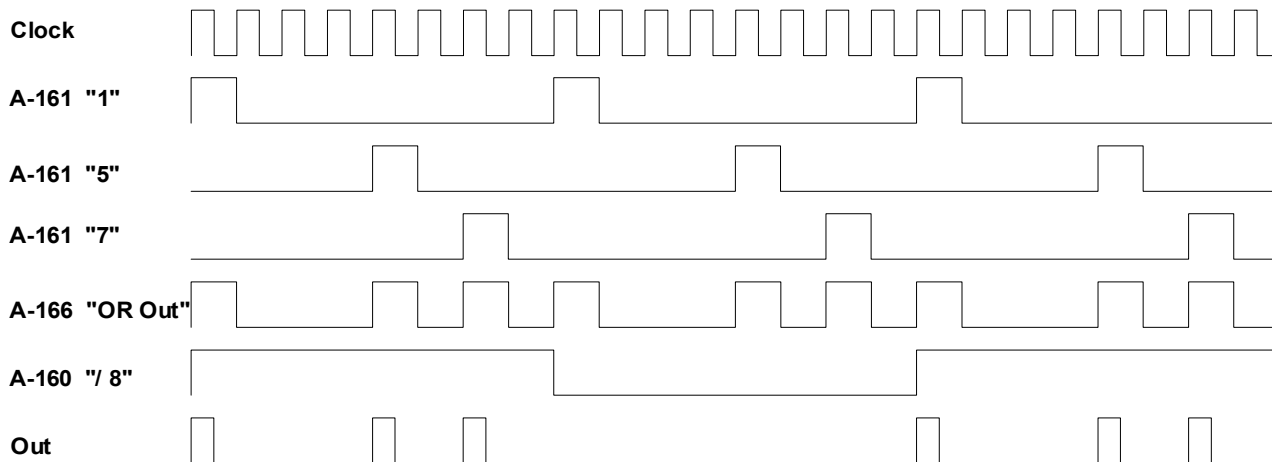
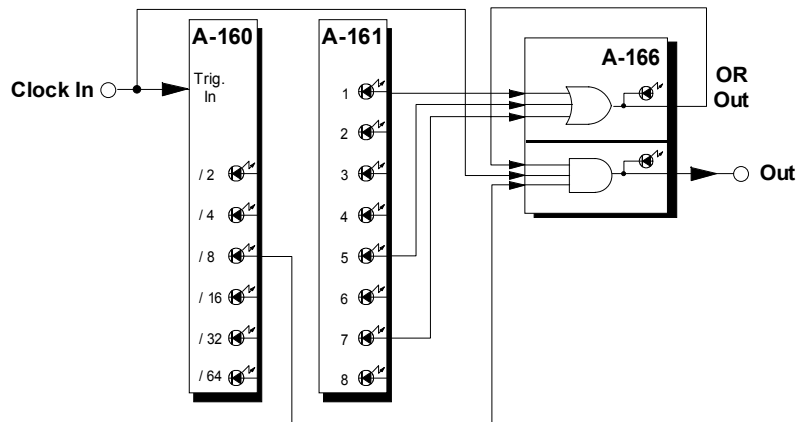

6. Patch-Sheet

The following diagrams of the module can help you recall your own **Patches**. They're designed so that a complete 19" rack of modules will fit onto an A4 sheet of paper.

Photocopy this page, and cut out the pictures of this and your other modules. You can then stick them onto another piece of paper, and create a diagram of your own system.

Make multiple copies of your composite diagram, and use them for remembering good patches and set-ups.



Draw in patchleads with colored pens.

