

## User Manual



# U-CONTROL UMX490/UMX610

The Ultimate Studio in a Box: 49-Key/61-Key USB/MIDI Controller Keyboard with USB/Audio Interface, 100 Software Instruments, 50 VST Effects, energyXT2.5 Compact Music Production Software and NI KorePlayer Software Sound Module

# Table of Contents

<b>Thank you</b> .....	<b>2</b>
<b>Important Safety Instructions</b> .....	<b>3</b>
<b>Legal Disclaimer</b> .....	<b>3</b>
<b>Limited Warranty</b> .....	<b>3</b>
<b>1. Before you get started</b> .....	<b>5</b>
1.1 Shipment.....	5
1.2 Initial operation and power supply.....	5
1.3 Online registration .....	5
1.4 System requirements .....	6
<b>2. Introduction to MIDI</b> .....	<b>6</b>
2.1 MIDI control for beginners .....	6
2.2 USB mode and stand-alone operation .....	7
2.2.1 USB mode.....	7
2.2.2 Stand-alone operation .....	7
<b>3. Control elements and connections</b> .....	<b>7</b>
<b>4. Operation</b> .....	<b>8</b>
4.1 PLAY mode .....	8
4.1.1 The FACTORY MEMORY .....	8
4.1.2 The USER MEMORY .....	8
4.2 ASSIGN mode .....	9
4.2.1 Setting the GLOBAL CHANNEL .....	9
4.2.2 Individual channel assignment .....	9
4.2.3 GLOBAL CHANNEL assignment.....	9
4.2.4 The PANIC key combination .....	9
4.2.5 The SNAPSHOT SEND command.....	9
4.2.6 Local Off.....	9
4.2.7 Control elements assignment .....	10
4.2.8 Program and bank change .....	10
4.2.9 Other functions of the OCTAVE SHIFT buttons	11
4.2.10 Velocity Sensitivity.....	12
4.2.11 The FACTORY RESET command.....	12
<b>5. Specifications</b> .....	<b>13</b>
<b>6. Appendix</b> .....	<b>14</b>

## Thank you

Thank you for showing your confidence in BEHRINGER products by purchasing the UMX. The UMX is an extremely flexible master keyboard with a controller unit that can be used for a wide array of applications. Whether you need independent control of computer rack synthesizers, General MIDI sound modules or effects devices, or want to use the UMX for conveniently operating sequencing software or computer plug-ins—the UMX offers you tremendous ease of use and allows you to realize your ideas intuitively.

## EN Important Safety Instructions



Terminals marked with this symbol carry electrical current of sufficient magnitude to constitute risk of electric shock. Use only high-quality commercially-available speaker cables with ¼" TS plugs pre-installed. All other installation or modification should be performed only by qualified personnel.



This symbol, wherever it appears, alerts you to the presence of uninsulated dangerous voltage inside the enclosure - voltage that may be sufficient to constitute a risk of shock.



This symbol, wherever it appears, alerts you to important operating and maintenance instructions in the accompanying literature. Please read the manual.



### Caution

To reduce the risk of electric shock, do not remove the top cover (or the rear section). No user serviceable parts inside. Refer servicing to qualified personnel.



### Caution

To reduce the risk of fire or electric shock, do not expose this appliance to rain and moisture. The apparatus shall not be exposed to dripping or splashing liquids and no objects filled with liquids, such as vases, shall be placed on the apparatus.



### Caution

These service instructions are for use by qualified service personnel only. To reduce the risk of electric shock do not perform any servicing other than that contained in the operation instructions. Repairs have to be performed by qualified service personnel.

1. Read these instructions.
2. Keep these instructions.
3. Heed all warnings.
4. Follow all instructions.
5. Do not use this apparatus near water.
6. Clean only with dry cloth.
7. Do not block any ventilation openings. Install in accordance with the manufacturer's instructions.
8. Do not install near any heat sources such as radiators, heat registers, stoves, or other apparatus (including amplifiers) that produce heat.

9. Do not defeat the safety purpose of the polarized or grounding-type plug. A polarized plug has two blades with one wider than the other. A grounding-type plug has two blades and a third grounding prong. The wide blade or the third prong are provided for your safety. If the provided plug does not fit into your outlet, consult an electrician for replacement of the obsolete outlet.

10. Protect the power cord from being walked on or pinched particularly at plugs, convenience receptacles, and the point where they exit from the apparatus.

11. Use only attachments/accessories specified by the manufacturer.



12. Use only with the cart, stand, tripod, bracket, or table specified by the manufacturer, or sold with the apparatus. When a cart is used, use caution when moving the cart/apparatus combination to avoid

injury from tip-over.

13. Unplug this apparatus during lightning storms or when unused for long periods of time.

14. Refer all servicing to qualified service personnel. Servicing is required when the apparatus has been damaged in any way, such as power supply cord or plug is damaged, liquid has been spilled or objects have fallen into the apparatus, the apparatus has been exposed to rain or moisture, does not operate normally, or has been dropped.

15. The apparatus shall be connected to a MAINS socket outlet with a protective earthing connection.

16. Where the MAINS plug or an appliance coupler is used as the disconnect device, the disconnect device shall remain readily operable.



## Legal Disclaimer

Technical specifications and appearance are subject to change without notice. The information contained herein is correct at the time of printing. All trademarks are the property of their respective owners. MUSIC Group accepts no liability for any loss which may be suffered by any person who relies either wholly or in part upon any description, photograph or statement contained herein. Colors and specifications may vary slightly from product. BEHRINGER products are sold through authorized dealers only. Distributors and dealers are not agents of MUSIC Group and have absolutely no authority to bind MUSIC Group by any express or implied undertaking or representation. This manual is copyrighted. No part of this manual may be reproduced or transmitted in any form or by any means, electronic or mechanical, including photocopying and recording of any kind, for any purpose, without the express written permission of Red Chip Company Ltd.

ALL RIGHTS RESERVED.  
© 2010 Red Chip Company Ltd.  
Trident Chambers, Wickhams Cay, P.O. Box 146,  
Road Town, Tortola, British Virgin Islands

## Limited Warranty

### § 1 Warranty

1. This limited warranty is valid only if you purchased the product from a BEHRINGER authorized dealer in the country of purchase. A list of authorized dealers can be found on BEHRINGER's website [behringer.com](http://behringer.com) under "Where to Buy", or you can contact the BEHRINGER office closest to you.

2. MUSIC Group\* warrants the mechanical and electronic components of this product to be free of defects in material and workmanship if used under normal operating conditions for a period of one (1) year from the original date of purchase (see the Limited Warranty terms in § 4 below), unless a longer minimum warranty period is mandated by applicable local laws. If the product shows any defects within the specified warranty period and that defect is not excluded under § 4, MUSIC Group shall, at its discretion, either replace or repair the product using suitable new or reconditioned product or parts. In case MUSIC Group decides to replace the entire product, this limited warranty shall apply to the replacement product for the remaining initial warranty period, i.e., one (1) year (or otherwise applicable minimum warranty period) from the date of purchase of the original product.

3. Upon validation of the warranty claim, the repaired or replacement product will be returned to the user freight prepaid by MUSIC Group.

4. Warranty claims other than those indicated above are expressly excluded.

PLEASE RETAIN YOUR SALES RECEIPT. IT IS YOUR PROOF OF PURCHASE COVERING YOUR LIMITED WARRANTY. THIS LIMITED WARRANTY IS VOID WITHOUT SUCH PROOF OF PURCHASE.

### § 2 Online registration

Please do remember to register your new BEHRINGER equipment right after your purchase at [behringer.com](http://behringer.com) under "Support" and kindly read the terms and conditions of our limited warranty carefully. Registering your purchase and equipment with us helps us process your repair claims quicker and more efficiently. Thank you for your cooperation!

### § 3 Return materials authorization

1. To obtain warranty service, please contact the retailer from whom the equipment was purchased. Should your BEHRINGER dealer not be located in your vicinity, you may contact the BEHRINGER distributor for your country listed under "Support" at [behringer.com](http://behringer.com). If your country is not listed, please check if your problem can be dealt with by our "Online Support" which may also be found under "Support" at [behringer.com](http://behringer.com). Alternatively, please submit an online warranty claim at [behringer.com](http://behringer.com) BEFORE returning the product. All inquiries must be accompanied by a description of the problem and the serial number of the product. After verifying the product's warranty eligibility with the original sales receipt, MUSIC Group will then issue a Return Materials Authorization ("RMA") number.

- ② Subsequently, the product must be returned in its original shipping carton, together with the return authorization number to the address indicated by MUSIC Group.
- ③ Shipments without freight prepaid will not be accepted.

#### § 4 Warranty Exclusions

- ① This limited warranty does not cover consumable parts including, but not limited to, fuses and batteries. Where applicable, MUSIC Group warrants the valves or meters contained in the product to be free from defects in material and workmanship for a period of ninety (90) days from date of purchase.
- ② This limited warranty does not cover the product if it has been electronically or mechanically modified in any way. If the product needs to be modified or adapted in order to comply with applicable technical or safety standards on a national or local level, in any country which is not the country for which the product was originally developed and manufactured, this modification/adaptation shall not be considered a defect in materials or workmanship. This limited warranty does not cover any such modification/adaptation, regardless of whether it was carried out properly or not. Under the terms of this limited warranty, MUSIC Group shall not be held responsible for any cost resulting from such a modification/adaptation.
- ③ This limited warranty covers only the product hardware. It does not cover technical assistance for hardware or software usage and it does not cover any software products whether or not contained in the product. Any such software is provided "AS IS" unless expressly provided for in any enclosed software limited warranty.
- ④ This limited warranty is invalid if the factory-applied serial number has been altered or removed from the product.
- ⑤ Free inspections and maintenance/repair work are expressly excluded from this limited warranty, in particular, if caused by improper handling of the product by the user. This also applies to defects caused by normal wear and tear, in particular, of faders, crossfaders, potentiometers, keys/buttons, guitar strings, illuminants and similar parts.
- ⑥ Damage/defects caused by the following conditions are not covered by this limited warranty:
- improper handling, neglect or failure to operate the unit in compliance with the instructions given in BEHRINGER user or service manuals;
  - connection or operation of the unit in any way that does not comply with the technical or safety regulations applicable in the country where the product is used;
  - damage/defects caused by acts of God/Nature (accident, fire, flood, etc) or any other condition that is beyond the control of MUSIC Group.

- ⑦ Any repair or opening of the unit carried out by unauthorized personnel (user included) will void the limited warranty.
- ⑧ If an inspection of the product by MUSIC Group shows that the defect in question is not covered by the limited warranty, the inspection costs are payable by the customer.

⑨ Products which do not meet the terms of this limited warranty will be repaired exclusively at the buyer's expense. MUSIC Group or its authorized service center will inform the buyer of any such circumstance. If the buyer fails to submit a written repair order within 6 weeks after notification, MUSIC Group will return the unit C.O.D. with a separate invoice for freight and packing. Such costs will also be invoiced separately when the buyer has sent in a written repair order.

⑩ Authorized BEHRINGER dealers do not sell new products directly in online auctions. Purchases made through an online auction are on a "buyer beware" basis. Online auction confirmations or sales receipts are not accepted for warranty verification and MUSIC Group will not repair or replace any product purchased through an online auction.

#### § 5 Warranty transferability

This limited warranty is extended exclusively to the original buyer (customer of authorized retail dealer) and is not transferable to anyone who may subsequently purchase this product. No other person (retail dealer, etc.) shall be entitled to give any warranty promise on behalf of MUSIC Group.

#### § 6 Claim for damage

Subject only to the operation of mandatory applicable local laws, MUSIC Group shall have no liability to the buyer under this warranty for any consequential or indirect loss or damage of any kind. In no event shall the liability of MUSIC Group under this limited warranty exceed the invoiced value of the product.

#### § 7 Limitation of liability

This limited warranty is the complete and exclusive warranty between you and MUSIC Group. It supersedes all other written or oral communications related to this product. MUSIC Group provides no other warranties for this product.

#### § 8 Other warranty rights and national law

- ① This limited warranty does not exclude or limit the buyer's statutory rights as a consumer in any way.
- ② The limited warranty regulations mentioned herein are applicable unless they constitute an infringement of applicable mandatory local laws.
- ③ This warranty does not detract from the seller's obligations in regard to any lack of conformity of the product and any hidden defect.

#### § 9 Amendment

Warranty service conditions are subject to change without notice. For the latest warranty terms and conditions and additional information regarding MUSIC Group's limited warranty, please see complete details online at [behringer.com](http://behringer.com).

\* MUSIC Group Macao Commercial Offshore Limited of Rue de Pequim No. 202-A, Macau Finance Centre 9/J, Macau, including all MUSIC Group companies

# 1. Before You Get Started

## 1.1 Shipment

The U-CONTROL was carefully packed at the assembly plant to assure secure transport. Should the condition of the cardboard box suggest that damage may have taken place, please inspect the unit immediately and look for physical indications of damage.

- ◆ **Damaged equipment should NEVER be sent directly to us. Please inform the dealer from whom you acquired the unit immediately as well as the transportation company from which you took delivery of the unit. Otherwise, all claims for replacement/repair may be rendered invalid.**
- ◆ **To assure optimal protection of your UMX during transport, we recommend utilizing a carrying case.**
- ◆ **Please always use the original packaging to avoid damage due to storage or shipping.**
- ◆ **Never let unsupervised children play with the device or with its packaging.**
- ◆ **Please dispose of all packaging materials in an environment-friendly fashion.**

## 1.2 Initial operation and power supply

Please make sure that the unit is provided with sufficient ventilation, and never place the UMX on top of an amplifier or in the vicinity of a heater to avoid the risk of overheating.

The power supply can be realized in different ways depending on the main application area. For the installation of the UMX in a studio environment, it is possible to connect the device directly to a free USB port of the computer using the USB cable provided (see Fig. 1.1).

In case it is not possible to establish the power supply over USB (e.g. because of an overload of the host computer due to several USB devices connected), it is also possible to operate the UMX with three 1.5-Volt batteries (type "AA", see Fig. 1.2).

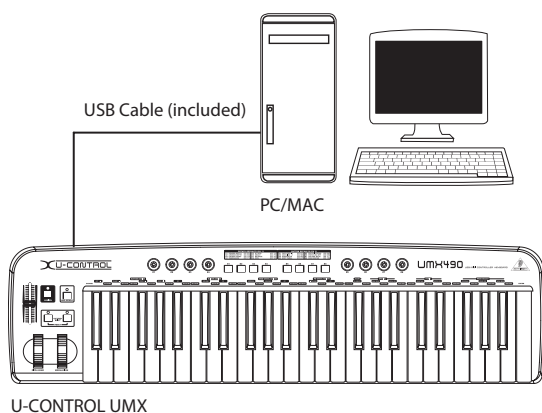

Fig. 1.1: Power supply via USB.

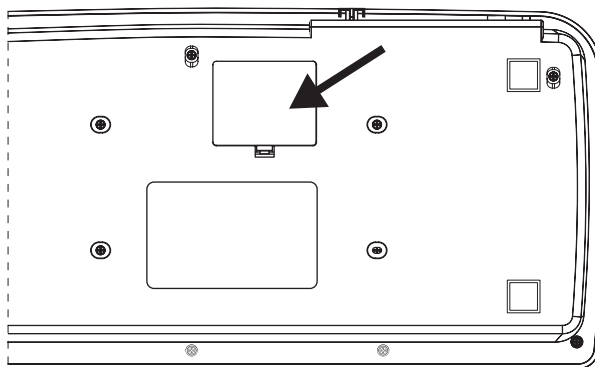

Fig. 1.2: The battery compartment on the bottom side of the UMX.

Open the battery compartment by pressing the shutter clamp carefully in the direction of the battery compartment, while pulling the cover of the compartment upwards.

Please note the following points when inserting the batteries:

- The +symbol of the batteries must coincide with the +symbol of the compartment! Incorrect polarity will damage the electronics!
- Do not mix old and new batteries! When you change the batteries, always change all 3 batteries at the same time.
- Do not use damaged batteries. The UMX could be damaged due to the leakage of chemicals.
- If you do not use the unit for an extended period of time, please remove the batteries from the compartment. Here again, the batteries could leak and damage the device.

After inserting the batteries, please close the battery compartment and make sure the shutter clamp snaps into place again. If you neither want to connect the power supply over USB nor operate the device with batteries, there is yet another possibility to connect the UMX over an external power supply unit. Please observe the correct operational data (DC 9 V; 100 mA) and correct polarity of the connector plug; you will find information about this above the DC input on the rear of the unit. Reverse polarity can damage the electronics.

## 1.3 Online registration

Please register your new BEHRINGER equipment right after your purchase by visiting <http://behringer.com> and read the terms and conditions of our warranty carefully.

Should your BEHRINGER product malfunction, it is our intention to have it repaired as quickly as possible. To arrange for warranty service, please contact the BEHRINGER retailer from whom the equipment was purchased. Should your BEHRINGER dealer not be located in your vicinity, you may directly contact one of our subsidiaries. Corresponding contact information is included in the original equipment packaging (Global Contact Information/European Contact Information). Should your country not be listed, please contact the distributor nearest you. A list of distributors can be found in the support area of our website (<http://behringer.com>).

Registering your purchase and equipment with us helps us process your repair claims more quickly and efficiently.

Thank you for your cooperation!

## 1.4 System requirements

For USB operation, a current WINDOWS PC or MAC with a USB connection is sufficient. Both USB 1.1 and USB 2.0 are supported.

- ◆ The UMX supports the USB MIDI compatibility of WINDOWS XP, Vista and MAC OS X operating systems.
- ◆ The UMX can also be operated as a stand-alone MIDI controller with no PC connected. Software control via MIDI is also possible, provided your computer has a MIDI interface.

## 2. Introduction to MIDI

### 2.1 MIDI control for beginners

Application possibilities for the UMX models are truly wide-ranging. We'll start with a couple of general explanations and examples that should quickly let you get a good understanding of MIDI basics.

The definition of the MIDI standard began in 1982 with the cooperation of various international companies (MIDI: Musical Instrument Digital Interface). At that time, musicians were looking for a possibility of managing the communication of electronic musical instruments of different makes with one another.

#### What exactly does the UMX do?

Simply put, this is a remote control for all kinds of MIDI equipment. Using the faders, rotary knobs and buttons, the foot pedal and the keyboard, an entire array of control instructions can be generated, which in turn can control the most diverse functions of external devices.

#### What kinds of equipment can I control with the UMX?

You can basically control any device supporting the MIDI format. Both hardware and software MIDI devices are controlled in exactly the same way. The only difference is in the wiring. Here are a couple of suggestions on how you can use your UMX:

- Editing sound parameters of (virtual) synthesizers, sound samplers, GM/GS/XG sound generators
- Controlling parameters on effects equipment/software plug-ins such as effects processors, reverbs, compressors, equalizers
- Remotely controlling software mixers (volume, panorama, mute functions, etc.) Remotely controlling transport functions (playback, forward, stop, etc.) on sequencers, hard disk recorders, drum computers, etc. Live control of volume and sound parameters on expanders
- Remotely controlling groove boxes, step sequencers, MIDI generators and other "live" software
- Program changes and volume control on sound generators (just like on a master keyboard)
- Can be used by band keyboardists, solo entertainers, organists, electronic music performers, DJs, sound engineers, home/project studio owners, theater technicians, etc.

#### And how does it work?

Remote control is realized by assigning the individual control elements of the UMX to individual MIDI parameters. Whenever one of these control elements is operated, the UMX generates the control data assigned to this control element, which are then transferred to external devices over a data link. Thus, for example, the VOLUME/DATA fader is factory-set to send data controlling the volume level of a channel.

The data connection is usually a standard MIDI cable with a 5-pin DIN plug on each end. Such cables should not exceed a length of 15 meters. With the UMX there is one more data connection available: the USB cable to the host computer. Here, the cable should not exceed a length of 5 meters.

The data transmission takes place over 16 channels.

The control data generated by the individual control elements are also called MIDI messages, which can be divided into 3 major groups:

- **Channel Messages:** Here, channel-specific control information is transmitted. An example of a channel message is the note-on instruction. As soon as a key is played on the keyboard of the UMX, the device generates an instruction which contains the pitch, channel number and velocity. The receiving sound generator "knows" which tone has to be played.
- **System Messages:** These messages are not channel-specific but relate to the entire system to which they are sent. They are divided into 3 groups: System Exclusive Messages (for operating system backup, updates, management of memory contents); System Real-Time Messages (e.g. for remote control of other devices); System Common Messages (e.g. for the synchronization of several devices).
- **Control Messages:** Also known as Control Changes or Controllers, abbreviated as "CC... (Control Change)". There are 128 controllers in total, which are numbered from 0 to 127.
- ◆ Please refer to Table 6.1 to find out which type of controller you are currently working with.
- ◆ MIDI data are only control data and contain no audible audio information! The data transmission takes place over 16 channels.

#### What settings do I have to make? Where? How?

Basically, which control element generates which controller must be set on the UMX, and how incoming controller commands should be interpreted must be set on the receiving device. Regarding controller assignment, there are two possible principles:

- You use the preset controller configuration set in the factory (see Fig. 3.1). In this case, you only need to make the assignments on the receiving device.
- You use your own controller configuration set up in ASSIGN mode. How to assign controllers to the UMX is described in Chapter 4 "Operation".

## 2.2 USB mode and stand-alone operation

The UMX can be operated as a USB interface or stand-alone device. The two modes are different with respect to the MIDI signal flow.

### 2.2.1 USB mode

When the UMX is linked via USB to a computer, the signal flow is as shown below (Fig. 2.1).

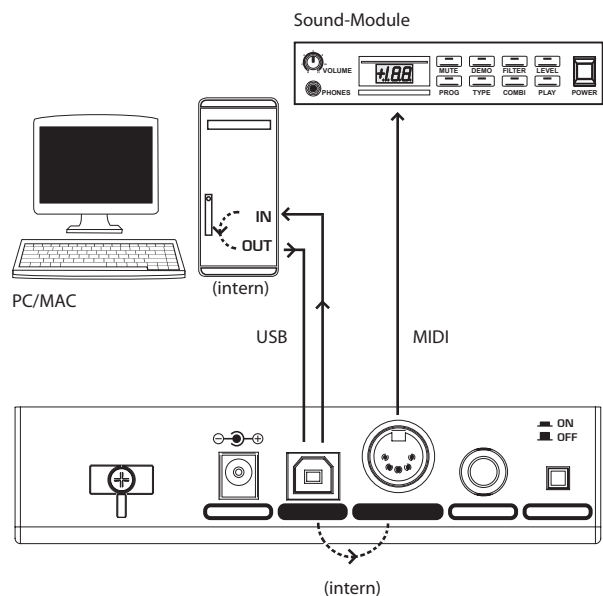

Fig 2.1: Block diagram of MIDI signal flow

After the UMX has been connected to the host computer, a virtual MIDI IN and MIDI OUT interface is emulated.

MIDI data generated in the UMX are first sent over the USB interface to the host computer, where they are received at the emulated MIDI IN. A sequencer software running on the host computer receives the MIDI data via the MIDI IN and relays them to the emulated MIDI OUT—if all sequencer parameters are set properly. The data are then sent back to the UMX via the USB interfaces on the computer/UMX, where they are looped through to the physical MIDI OUT <sup>14</sup>. From here, the MIDI data are sent to the devices connected to the MIDI OUT.

The MIDI OUT connector <sup>14</sup> can also be used as a normal MIDI interface, independently of the sequencer software operating the UMX.

### 2.2.2 Stand-alone operation

When the UMX is not linked via USB to a computer, it is automatically set to stand-alone mode. In this case, the UMX can only send out MIDI data from its MIDI OUT connector.

## 3. Control Elements and Connections

♦ The following factory settings refer to GLOBAL MIDI channel 1.

- 1 The **keyboard** of the UMX has 49 or 61 large, velocity-sensitive keys for maximum playing comfort. The keyboard not only provides for playing, but also functions as an encoder in the context of the assignment procedure.
- 2 The **MODULATION** wheel is factory-set to function as a conventional modulation wheel (MIDI CC 1). In ASSIGN mode, any MIDI controller can be assigned to it. When you release the MODULATION wheel, it retains its adjusted value.
- 3 The **PITCH BEND** wheel is normally used to change the pitch in real time. In this way, a sound can be “bent” upwards/downwards by several semitones while playing. As a default factory setting, pitch bending is assigned to this wheel. However, in ASSIGN mode you can assign any MIDI control command to the pitch wheel.
- 4 Ex works, the **VOLUME/DATA** fader controls the volume of the notes played on the keyboard (MIDI CC 7). In ASSIGN mode, it can be set to control any MIDI controller.
- 5 The **ASSIGN** button allows you to assign different functions to the various control elements.

The basic principle is always the same:

- 1) Press the **ASSIGN** button and **keep it pressed**. The status LED above the button lights up. The UMX signals that it has entered ASSIGN mode.
- 2) Select the control element to which you would like to assign a new MIDI function by operating it.
- 3) Release the **ASSIGN** button.
- 4) Depending on the choice you made, you may have to define an additional value range (see below for more details).
- 5) Press the **ENTER** key on the keyboard to confirm your assignments. To discard your assignments either press the **CANCEL** key or the **ASSIGN** button again. In either case, the **ASSIGN** LED goes out and the UMX quits ASSIGN mode.
- 6) The **USER MEMORY** button is used to recall the internal memory. The internal memory contains all assignment information set in ASSIGN mode. Any changes that were made after **USER MEMORY** selection are automatically saved without further user prompts. The **USER MEMORY** is retained even after the unit is switched off.
- 7) The two **OCTAVE SHIFT** buttons are preset to shift the keyboard range by up to three octaves up or down. The associated LEDs help you identify the current octave setting (see Table 3.1). Since the **OCTAVE SHIFT** buttons can also be assigned to any MIDI controller, we would like to refer you to Chapters 4.2.8 and 4.2.9 for detailed information.
- 8) The eight high-resolution rotary controls **R1 – R8** generate continuous controller information. They are the controllers that are shown above the buttons in the table 10. All rotary controllers can be assigned to any controller in ASSIGN mode.
- 9) The eight buttons **B1 – B8** generate switch controllers. Again, they are assigned to various default functions (see table on the device). Like the rotary controls, the buttons can be freely assigned to any controller in ASSIGN mode.
- 10) The table shows the factory-set controller assignments.
- 11) **Keyboard legend**: Informs you about the special functions performed by individual keys on the keyboard. The individual elements of the keyboard legend are described in detail in Chapter 4 “OPERATION”.

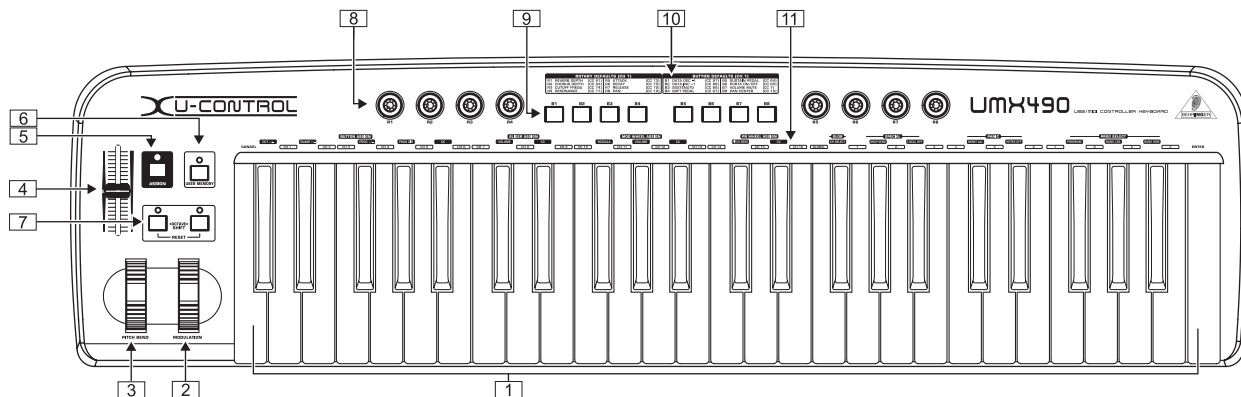

Fig. 3.1: Top view of the UMX

Operation	Octave shift	LED
press once	Shift one octave up or down	LED on
press 2nd time	Shift 2 octaves up or down	flashing
press 3rd time	Shift 3 octaves up or down	flashing
press both buttons	Reset (all octave shifts are reversed)	LED off

Table 3.1: LED activity depending on the OCTAVE SHIFT status

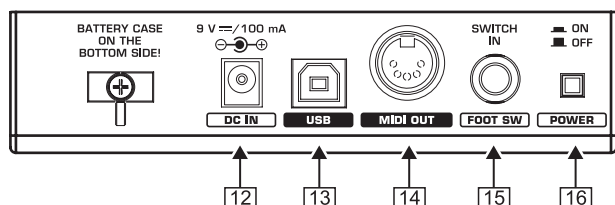

Fig. 3.2: Rear panel connectors

- 12 Use this socket to supply the UMX with current from an external power supply unit (not included).
  - 13 The **USB** connector of the UMX. The connector (type B) on the device is connected using the cable supplied to a free slot on the host computer (where you will find a type A connector). It is compatible with the USB1.1 and/or USB2.0 standards.
  - 14 In addition to the connection to the computer, you can use the MIDI OUT to connect additional MIDI devices, so that the UMX transforms into a fully-featured, easily accessible MIDI interface for your host computer.
  - 15 Use the **FOOT SWITCH** connector to connect a sustain pedal. This port is factory-set and assigned to the MIDI parameter "Foot Pedal" (CC 64), which represents a switch controller. When the pedal is pressed (and held) in normal Play mode, it generates a controller with the value 127. When the pedal is released, the controller falls back to 0 (typical piano sustain pedal behavior). Apart from that the pedal assignment is the same as the button assignment, i.e. you can assign any MIDI controller to it.
  - 16 The **POWER** switch is used to switch the unit on and off.
- ◆ Please close all programs if you want to switch off the UMX while the computer is running or terminate the USB connection.

## 4. Operation

In the following, we will explain the operation of the UMX in detail. Please note the differentiation between push-buttons (refer to control elements 10) and keys (control element 11)! Please do not confuse these!

### 4.1 PLAY mode

The UMX is in the PLAY mode immediately after it is switched on. Here you can immediately begin to play, modify the filtering process via the rotary controls, execute panning, control software synthesizers and so on.

#### 4.1.1 The FACTORY MEMORY

The FACTORY MEMORY is the installed memory in which the basic settings of the UMX are defined. The controller map described under 10 is the most important item of the FACTORY MEMORY. These settings are automatically loaded after each start of the device and control many useful parameters.

Instructions which are changed within a session are discarded when the device is switched off. We have equipped the UMX with a USER MEMORY, in order to still be able to store changed allocations.

#### 4.1.2 The USER MEMORY

Settings which are stored in the USER MEMORY remain stored in the internal Flash ROM and are retained after the device is switched off.

Change to the USER MEMORY by pressing push-button 9. If you call up the USER MEMORY for the first time, the settings of the FACTORY MEMORY will be used initially. As soon as you execute changes in the existing controller map, they are automatically stored without requiring any further action.

In the USER MEMORY, allocations including channel information of the following control elements can be permanently stored:

- FOOT SWITCH connector
- OCTAVE SHIFT buttons
- VOLUME/DATA fader
- PITCH BEND wheel
- MODULATION wheel
- Rotary controls R1 – R8
- Push-Buttons B1 – B8



## 4.2 ASSIGN mode

As already mentioned in previous chapters, the ASSIGN Mode is a powerful tool to optionally reconfigure the UMX into an ultra-comfortable controller.

The basic logic of the allocation process has been introduced to you in Chapter 3 “Control elements and connections”. In the following we will offer you more detailed information to enable you to use the UMX even more efficiently.

### 4.2.1 Setting the GLOBAL CHANNEL

The UMX recognizes two separate classifications in regard to MIDI channels. There is a GLOBAL CHANNEL and 16 SINGLE CHANNELS.

The GLOBAL MIDI CHANNEL is the channel through which all MIDI commands are sent in the factory setting: messages by various control elements, as well as the Note On and Note Off commands. To change this channel, proceed as follows:

- 1) Press the ASSIGN button and hold it down.
- 2) Press the **CH SELECT** key.
- 3) Release the ASSIGN push-button.
- 4) Define the GLOBAL CHANNEL by operating one of the keys **CH 1** through **CH 16** on the keyboard.
- 5) Finally, press the **ENTER** key. In order to discard your assignments, please press the **CANCEL** key or press the ASSIGN push-button again. The ASSIGN LED will go off in all 3 cases.

♦ The factory setting for the GLOBAL CHANNEL is channel 1.

### 4.2.2 Individual channel assignment

The assignment of individual control elements to defined channels is useful if you want to control several external devices independently from each other.

#### Example:

You are playing synthesizer A through channel 2 with the keyboard and have a sequencer program controlling another synthesizer B through channel 5. You can now control the filter frequency of device B through one of the eight jog/shuttle controls in real time and simultaneously continue to play device A without changing the filter frequency.

- 1) Press the ASSIGN push-button and **hold it down**.
- 2) Activate the control element, for which another channel than the GLOBAL CHANNEL is to be set. If this is a controller or fader, briefly move the control element; when you have decided on a push-button, press this push-button once. The UMX now “knows” which control element you would like to assign to a **SINGLE CHANNEL**.
- 3) Release the ASSIGN push-button.
- 4) Press one of the 16 channel keys **CH 1** through **CH 16**.
- 5) Finally, press the **ENTER** key. In order to discard your assignments, please select the **CANCEL** key or press the ASSIGN push-button again. The ASSIGN LED will go off in all 3 cases.

♦ **All control elements of the UMX follow the GLOBAL CHANNEL in their channel settings (factory settings). This means that a control element is always in the GLOBAL CHANNEL until you assign it to another channel. Please also consider this when you change the GLOBAL CHANNEL, since various elements will also change accordingly!**

### 4.2.3 GLOBAL CHANNEL assignment

- 1) Press the ASSIGN push-button and **hold it down**.
- 2) Activate the control element for which the GLOBAL CHANNEL is to be set. If this is a controller or fader, briefly move the control element; when you have decided on a push-button, press this push-button once. The UMX now “knows” to which control element you would like to assign a GLOBAL CHANNEL.
- 3) Release the ASSIGN push-button.
- 4) Press the **GLOBAL** key.
- 5) Finally, press the **ENTER** key. In order to discard your assignments, please press the **CANCEL** key or press the ASSIGN push-button again. The ASSIGN LED will go off in all 3 cases.

### 4.2.4 The PANIC key combination

Imagine that you have been working continuously on one song for several hours and a note suddenly “hangs up”. If you now execute a PANIC command, a sound producing device receiving this command becomes silent immediately.

- 1) Press the ASSIGN push-button and hold it down.
- 2) Press one of the two PANIC keys, **RESET ALL** or **NOTES OFF**.
- 3) Release the ASSIGN push-button. The device will automatically return to the normal play mode.

♦ The command “All Notes Off” will be sent immediately after you have pressed one of the two keys.

### 4.2.5 The SNAPSHOT SEND command

The SNAPSHOT command triggers the transmission of all parameters including their current values. All control element assignments as well as their temporary settings on the respective channels are transmitted to the MIDI OUT socket and to the USB output of the UMX.

It is possible by this method to transfer the complete UMX mapping to a sequencer software at the beginning of a song. This is to make sure the song is played with the last valid controller values. Apart from this, the SNAPSHOT allows you to reset the correct values in an external device where parameters have shifted.

- 1) Press the ASSIGN push-button and **hold it down**.
- 2) Press the **SNAP SEND** key on the keyboard.
- 3) Release the ASSIGN push-button. The device automatically returns to the normal play mode.

♦ The SNAPSHOT command is transmitted immediately after activating the keyboard.

### 4.2.6 Local Off

The LOCAL OFF in the UMX has the effect that value entries made via the control elements are neither transmitted to the MIDI OUT socket nor to the USB OUT. It is therefore possible in the LOCAL OFF mode, for example, to read just the rotary controls without transmitting data to the generally selected external devices.

- 1) Press the ASSIGN push-button and **hold it down**.
- 2) Press the **LOCAL OFF** key.
- 3) Release the ASSIGN push-button again and complete the desired settings on the control elements.
- 4) Then, press the **ENTER** key or the **CANCEL** key. The LED of the ASSIGN key goes off in both cases and you are in normal play mode again.

### 4.2.7 Control elements assignment

We explained in Chapter 4.2.2 how an individual channel can be assigned to each control element. You will now find out how to assign new controllers and a channel.

#### a) The assignment for rotary controls R1 – R8, the MODULATION controller, the PITCH BEND wheel, as well as the DATA fader.

- 1) Press the ASSIGN push-button and **hold it down**.
- 2a) If you would like to assign one of the eight **rotary controls**, turn the respective controller.
- 2b) If you assign the **MODULATION controller**, please activate one of the keys located below the lettering **MOD WHEEL ASSIGN**, **MODULA**, **VOLUME** or **CC**. You can bypass step 5, if you decide on the **MODULA** or the **VOLUME** key. The MIDI controller "MODULATION" (CC 1) or "CHANNEL VOLUME" (CC 7) is then directly assigned to the MODULATION controller without having to enter a controller number first.
- 2c) If you assign the **PITCH BEND wheel**, please activate one of the keys located below the lettering **PB WHEEL ASSIGN**, **PITCH BEND** or **CC**. You can bypass step 5, if you decide on the **PITCH BEND** key. The original pitch bend function is then directly assigned to the PITCH BEND wheel.
- 2d) If you complete an assignment for the **DATA fader**, please activate one of the keys located below the lettering **SLIDER ASSIGN**, **VOLUME** or **CC**. You can bypass step 5 if you decide on the **VOLUME** key. The original volume function is then directly assigned to the DATA fader.
- 3) Release the ASSIGN push-button again.
- 4) Press one of the 16 channel push-buttons **CH 1** through **CH 16** to define the channel.
- 5) Press the number keys on the keyboard in sequence until you have completely entered the desired controller number. Only value entries between 0 and 127 are possible. Greater values are ignored by the device.

#### Examples:

- Press keys **1** and **4** if you have decided on CC 14, for example.
- Press keys **1**, **0** and **7** if you would like to select CC 107.
- 6) Finally press the **ENTER** key. In order to discard your assignments, please press the **CANCEL** key or press the ASSIGN push-button again. The LED of the ASSIGN push button will go off in all 3 cases.

#### b) Assigning push-buttons B1 – B8 and the optional sustain pedal connected to the socket **15**.

- 1) Press the ASSIGN push-button and **hold it down**.
- 2) Press the related control element once (however, it is not necessary to continue pressing it).
- 3) Release the ASSIGN push-button again.
- 4) Press one of the 16 channel push-buttons **CH 1** through **CH 16** to define the channel.
- 5) Press the number keys on the keyboard in sequence until you have completely entered the desired controller number. Only value entries between 0 and 127 are possible. Greater values are ignored by the device.

- 6) Finally, press the **ENTER** key. In order to discard your assignments, please press the **CANCEL** key or press the ASSIGN push-button again. The LED of the ASSIGN push button will go off in all 3 cases.

Please note two exceptions in conjunction with the push-buttons and/or the sustain pedal.

- ♦ If you assign CC 07 (Channel Volume) to the push-buttons, a channel volume of 0 is triggered each time you press the push-button. This means the channel is always mute. This feature is very useful for live operation.
- ♦ If you use controller CC 10 (panning) for the push-buttons or the sustain pedal, pressing the control element transmits value 64. This results in hearing the content of the channel in the center of the stereo panorama.

### 4.2.8 Program and bank change

You have three different options achieving a program change in external devices with the UMX. This is a very powerful function, which will enable you to use the full spectrum of all of your sound producers. Options a) and b) will allow you to select any programs by means of a defined selection procedure, which always has to be completed. The process is generally accelerated in the third option c), so that you will be able to directly select programs by pressing the push-button once.

#### a) If you are sure that you want to select from 128 different programs only, you will achieve the ASSIGN mode program change by the following method. As soon as the quantity of 128 is exceeded, however, you must apply the process described under paragraph b).

- 1) Press the ASSIGN push-button and hold it down.
- 2) Press one of the 16 white channel keys **CH 1** through **CH 16** on the keyboard. You have now defined the channel by which the program change will be transmitted.
- 3) Release the ASSIGN push-button.
- 4) Press the **PROGRAM** key.
- 5) Press the number keys in sequence until you have completely entered the desired program number. Only value entries between 0 and 127 are possible. Greater values are ignored by the device.

#### Examples:

- Press **1** and **5** if you have decided on program 15, for example.
- Press **1**, **2** and **7** if you would like to select program 127.
- 6) Press the **ENTER** key. In order to discard your assignments, please press the **CANCEL** key or press the ASSIGN push button again. The ASSIGN LED will go off in all 3 cases.

#### b) If you have more than 128 programs, you must apply the following process to achieve a program change. In this case, your programs will be organized in banks which are activated by a special MIDI command: the BANK SELECT command. In the following section, this command is briefly described. A brief introduction for this is listed in the following:

The BANK SELECT command consists of two parts: an MSB part and an LSB part.

The MSB part describes a value range of 128 different values and is the more important part of the DATA BASE SELECT command for many external devices.

The LSB part describes each of the 128 MSBs in another 128 individual stages. Both are individually numbered from 0 to 127.

The enormous value range of a total of  $128 \times 128 = 16,384$  different values is therefore available to you via the BANK SELECT command. This theoretically means that you could use external devices which support the same amount of different banks.

If you consider that each of these banks again contains another 128 individual programs, you will receive the unbelievably large number of 2,097,152 different options to organize these programs.

- 1) Press the ASSIGN push-button and hold it down.
- 2) Press one of the 16 channel keys  through , or press the  key.
- 3) Release the ASSIGN push-button.
- 4) Press the  key. Then press the number keys in sequence until you have completely entered the desired BANK MSB number. Only value entries between 0 and 127 are possible. Greater values are ignored by the device.

The BANK MSB has now been defined.

### Examples:

- Press  and  if you have decided on MSB 14, for example.
  - Press ,  and  if you would like to select MSB 107.
- 5) Now define the  by pressing the key. Then enter the number value of the BANK LSB with the already familiar procedure (see step 4). The same entry rules apply as for the BANK MSB. You have defined the bank in which the desired program will be called up in steps 4 and 5. Now all you have to define is the program itself:
  - 6) Press the  key and then press the number keys in sequence until you have completely entered the desired program number. Only entries between 0 and 127 are possible, greater values are ignored by the device. Ready!
  - 7) Finally, press the  key. In order to discard your assignments, please press the  key or press the ASSIGN push-button again. The ASSIGN LED will go off in all 3 cases.

### Example:

You want to select preset No. 49 in bank 25 of an external device on channel 14 via the UMX. Only the LSB will be used to describe the bank, since the bank number remains less than 128. The MSB in this case equals 0.

- 1) Press and hold the ASSIGN push-button.
- 2) Press the channel key .
- 3) Release the ASSIGN push-button.
- 4) Then, press the  key or the  key
- 5) Press  key and then describe bank 25 with push-buttons  and .
- 6) Define the program: Press the  key and then the  and  keys for program 49.
- 7) Press the  key.

### c) Direct program selection through the two OCTAVE SHIFT push-buttons.

- 1) Press the ASSIGN push-button and **hold it down**.
- 2) Select the OCTAVE SHIFT push-button which you want to assign to the program change function.
- 3) Release the ASSIGN push-button again.
- 4) Defined the channel by which the program change will be transmitted. Press one of the 16 channel keys  through  on the keyboard.
- 5) Press the  key. Then press the number keys on the keyboard in sequence until you have completely entered the desired preset number. Only value entries between 0 and 127 are possible. Greater values are ignored by the device.
- 6) Finally, press the  key. In order to discard your assignments, please select the  key or press the ASSIGN push-button again. The ASSIGN LED will go off in all 3 cases.

♦ As soon as you have assigned the direct program selection to one or both OCTAVE SHIFT push-buttons simultaneously, pressing both push-buttons will not activate ANYTHING!

### 4.2.9 Other functions of the OCTAVE SHIFT buttons

The OCTAVE SHIFT push-buttons of the device are in their initial state every time the UMX is switched on (see Table 3.1). Further special functions can be assigned to both push-buttons in the ASSIGN mode in addition to the already covered functions regarding direct program change and octave transposition:

- a) Transposition in individual semitone steps
- b) Sequential scrolling in program libraries
- c) Optional controller functions

♦ As soon as you assign a function to one of the two push-buttons, the second push-button will automatically assume the same function, however, it is still restricted in its functionality. It is not capable of sending data until you assign a function to this push-button with the ASSIGN procedure.

#### a) Transposition in individual semitone steps

- 1) Press the ASSIGN push-button and **hold it down**.
- 2) Press the  key.
- 3) Release the ASSIGN push-button.
- 4) Finally, press the  key. In order to discard your assignments, please press the  key or press the ASSIGN push-button again. The ASSIGN LED will go off in all 3 cases.

Pressing the right hand one of the two push-buttons causes a shift by one semitone upward pressing the left hand one leads to a shift by one semitone downward. Pressing both push-buttons cancels all transpositions.

♦ A keyboard can consist of a maximum of 128 semitones according to the MIDI standard. If you have reached the lower or upper end of this tone range with the transposition function, you cannot exceed the highest or lowest tone despite continued pressing of the transposition push-button. This also applies to the transposition in octave steps.

### b) Sequential scrolling in program libraries.

Most sound producers have the option to store presets in a separate bank (frequently called a User Bank). If the sequence of songs to be played at a concert is defined by your band, you can store all of the sounds used for the gig in the User Bank in the sequence they occur in the concert and completely concentrate on your playing. A cumbersome search for sounds in the sound producers is no longer required thanks to the OCTAVE SHIFT push-buttons.

- 1) Press the ASSIGN push-button and **hold it down**.
- 2) Press the **PROG +/-** key.
- 3) Release the ASSIGN push-button.
- 4) Finally, press the **ENTER** key. In order to discard your assignments, please press the **CANCEL** key or press the ASSIGN push-button again. The ASSIGN LED will go off in all 3 cases.

Pressing the right hand one of the two push-buttons now causes your external device to switch one preset number upward to be switched upward in your external device; pressing the left hand causes a step downward in your preset library. By pressing both push-buttons you jump to Preset 0 in the current bank.

Please note that you must assign an individual MIDI channel to the OCTAVE SHIFT push-buttons if you do not want to work in the GLOBAL CHANNEL (refer to Chapter 4.2.2).

♦ In case of the stepwise search function, the channel assignment always affects both the push-buttons. The assignment of a separate channel to one of the 2 push-buttons is not supported.

### c) Optional controller functions

Please note that the OCTAVE SHIFT push-buttons generate switch controllers in the event of a controller assignment. One of the two values 0 or 127 will always be produced.

- ♦ There are two exceptions: if you assign controller CC 07 (Channel Volume) to the OCTAVE SHIFT push-buttons, pressing one of the push-buttons will always generate the value 0. In case of controller CC 10 (panning), pressing a push-button will always produce the value 64.
- ♦ Please note that pressing both push-buttons simultaneously does not generate anything when assigning a controller.
  - 1) Press the ASSIGN button and **keep it pressed**.
  - 2) Press the one of the two OCTAVE SHIFT buttons to which you want to assign a controller.
  - 3) Release the ASSIGN button.
  - 4) Assign the channel. Press one of the 16 channel keys **CH 1** to **CH 16**. You can assign each of both the OCTAVE SHIFT buttons to an individual MIDI channel.
  - 5) Press the **CC** key to be found under **BUTTON ASSIGN**.
  - 6) Press the number keys on the keyboard to enter the controller number of your choice (as described in Chapter 4.2.7).
  - 7) Confirm your selection with **ENTER**. To discard your assignments either press the **CANCEL** key or the ASSIGN button again. In all 3 cases the ASSIGN LED goes out.

### 4.2.10 Velocity Sensitivity

The sensitivity of the UMX can be regulated so that the velocity of the keys has an effect on the volume level.

- 1) Press the ASSIGN button and keep it pressed.
- 2) Use the number keys to enter the keyboard velocity (see Table 4.1).
- 3) Release the ASSIGN button.
- 4) Confirm your selection with **ENTER**. To discard your assignments either press the **CANCEL** key or the ASSIGN button again. In all 3 cases the ASSIGN LED goes out.

Key	Effect on key velocity
0	OFF: velocity value is fixed to 110. Change of key pressure has no effect on volume level.
1	SOFT: key pressure is very sensitive; low velocity changes create high changes in volume level
2	MEDIUM: key pressure is "normal"; (very) hard hit notes are (very) loud, (very) soft hit notes produce (very) low volume
3	HARD: key pressure is more unsusceptible compared to all other settings
4-9	invalid input

Table 4.1: Effect of RANGE definition on keyboard velocity

### 4.2.11 The FACTORY RESET command

To reset all settings on your UMX, proceed as follows:

- 1) Press the ASSIGN push-button and **hold it down**.
- 2a) To cause a **temporary FACTORY RESET**, simultaneously press both OCTAVE SHIFT push-buttons. All temporarily changed control elements are returned to their factory settings. The USER MEMORY, however, is retained and will not be reset.
- 2b) Simultaneously press the **8**, **9** and **0** keys to perform a **complete FACTORY RESET**. In this case, the USER memory is also overwritten, in addition to resetting all control elements of the FACTORY MEMORY.
- 3) Release the ASSIGN push-button again. The LED of the ASSIGN push-button stays on.
- 4) Finally, press the **ENTER** key. If you do not wish to perform the RESET command, please press either the **CANCEL** key or press the ASSIGN push-button again.

## 5. Specifications

### USB Connections

Type	Type B; USB1.1
------	----------------

### MIDI connections

Type	5-pin DIN plug
------	----------------

### CONTROL ELEMENTS

Controller	1 control wheel with center reset 1 control wheel without center reset 8 rotary knobs 1 fader
------------	--

Buttons	12 buttons
---------	------------

### Keyboard

UMX610	61 keys; velocity-sensitive
--------	-----------------------------

UMX490	49 keys; velocity-sensitive
--------	-----------------------------

### SWITCH PLUG

Foot pedal	¼" mono jack with automatic polarity recognition
------------	--

### POWER SUPPLY

#### USB

Battery	3 x 1.5 Volt (Type "AA")
---------	--------------------------

Power connector	2 mm DC jack, negative center 9 V, 100 mA DC, regulated
	USA/Canada 120 V~, 60 Hz
	China/Korea 220 V~, 50 Hz
	UK/Australia 230 V~, 50 Hz
	Europe 230 V~, 50 Hz
	Japan 100 V~, 50–60 Hz

#### Power consumption

UMX610	max. 0.9 W
--------	------------

UMX490	max. 0.9 W
--------	------------

### DIMENSIONS/WEIGHT

#### Dimensions (W x H x D)

UMX610	approx. 8 15/32 x 3 26/32 x 38 31/32" approx. 215 x 97 x 990 mm
--------	--

UMX490	approx. 8 15/32 x 3 26/32 x 32 15/32" approx. 215 x 97 x 825 mm
--------	--

#### Weight

UMX610	approx. 10 11/32 lbs. / 4.69 kg
--------	---------------------------------

UMX490	approx. 8 7/32 lbs. / 3.90 kg
--------	-------------------------------

BEHRINGER is constantly striving to maintain the highest professional standards. As a result of these efforts, modifications may be made from time to time to existing products without prior notice. Specifications and appearance may differ from those listed or illustrated.

## 6. Appendix

### Standard MIDI Controller (CC) Numbers

00	Bank select	32	Bank select LSB	64	Damper Pedal (Sustain)	96	Data Entry +1 (Increment)
01	Modulation	33	Modulation LSB	65	Portamento On/Off	97	Data Entry -1 (Decrement)
02	Breath Controller	34	Breath Controller LSB	66	Sostenuto On/Off	98	NRPN LSB
03	Controller 3 (undefined)	35	Controller 35 (undefined)	67	Soft Pedal On/Off	99	NRPN MSB
04	Foot Controller	36	Foot Controller LSB	68	Legato Footswitch	100	RPN LSB
05	Portamento Time	37	Portamento Time LSB	69	Hold 2	101	RPN MSB
06	Data Entry MSB	38	Data Entry LSB	70	Sound Controller 1 (Sound Variation)	102	Controller 102 (undefined)
07	Channel Volume (formerly Main Volume)	39	Channel Volume LSB (formerly Main Volume)	71	Sound Controller 2 (Resonance/Timbre)	103	Controller 103 (undefined)
08	Balance	40	Balance LSB	72	Sound Controller 3 (Release Time)	104	Controller 104 (undefined)
09	Controller 9 (undefined)	41	Controller 41 (undefined)	73	Sound Controller 4 (Attack Time)	105	Controller 105 (undefined)
10	Pan	42	Pan LSB	74	Sound Controller 5 (Cut-off Frequency/Brightness)	106	Controller 106 (undefined)
11	Expression	43	Expression LSB	75	Sound Controller 6 (Decay Time)	107	Controller 107 (undefined)
12	Effect Control 1	44	Effect Control 1 LSB	76	Sound Controller 7 (Vibrato Rate)	108	Controller 108 (undefined)
13	Effect Control 2	45	Effect Control 2 LSB	77	Sound Controller 8 (Vibrato Depth)	109	Controller 109 (undefined)
14	Controller 14 (undefined)	46	Controller 46 (undefined)	78	Sound Controller 9 (Vibrato Delay)	110	Controller 110 (undefined)
15	Controller 15 (undefined)	47	Controller 47 (undefined)	79	Sound Controller 10 (undefined)	111	Controller 111 (undefined)
16	General Purpose 1	48	General Purpose 1 LSB	80	General Purpose 5	112	Controller 112 (undefined)
17	General Purpose 2	49	General Purpose 2 LSB	81	General Purpose 6	113	Controller 113 (undefined)
18	General Purpose 3	50	General Purpose 3 LSB	82	General Purpose 7	114	Controller 114 (undefined)
19	General Purpose 4	51	General Purpose 4 LSB	83	General Purpose 7	115	Controller 115 (undefined)
20	Controller 20 (undefined)	52	Controller 52 (undefined)	84	Portamento Control	116	Controller 116 (undefined)
21	Controller 21 (undefined)	53	Controller 53 (undefined)	85	Controller 85 (undefined)	117	Controller 117 (undefined)
22	Controller 22 (undefined)	54	Controller 54 (undefined)	86	Controller 86 (undefined)	118	Controller 118 (undefined)
23	Controller 23 (undefined)	55	Controller 55 (undefined)	87	Controller 87 (undefined)	119	Controller 119 (undefined)
24	Controller 24 (undefined)	56	Controller 56 (undefined)	88	Controller 88 (undefined)	120	All Sound Off
25	Controller 25 (undefined)	57	Controller 57 (undefined)	89	Controller 89 (undefined)	121	Reset All Controllers
26	Controller 26 (undefined)	58	Controller 58 (undefined)	90	Controller 90 (undefined)	122	Local Control On/Off
27	Controller 27 (undefined)	59	Controller 59 (undefined)	91	Effects 1 Depth (Reverb)	123	All Notes Off
28	Controller 28 (undefined)	60	Controller 60 (undefined)	92	Effects 2 Depth (Tremolo)	124	Omni Mode Off
29	Controller 29 (undefined)	61	Controller 61 (undefined)	93	Effects 3 Depth (Chorus)	125	Omni Mode On
30	Controller 30 (undefined)	62	Controller 62 (undefined)	94	Effects 4 Depth (Celeste/Detune)	126	Poly Mode Off/Mono Mode On
31	Controller 31 (undefined)	63	Controller 63 (undefined)	95	Effects 5 Depth (Phaser)	127	Poly Mode On/Mono Mode Off

Tab. 6.1: MIDI controller overview

# FEDERAL COMMUNICATIONS COMMISSION COMPLIANCE INFORMATION



Responsible party name: **BEHRINGER USA, Inc.**  
Address: **18912 North Creek Parkway,  
Suite 200 Bothell, WA 98011,  
USA**  
Phone/Fax No.: **Phone: +1 425 672 0816  
Fax: +1 425 673 7647**

## U-CONTROL UMX490/UMX610

complies with the FCC rules as mentioned in the following paragraph:

This equipment has been tested and found to comply with the limits for a Class B digital device, pursuant to part 15 of the FCC Rules. These limits are designed to provide reasonable protection against harmful interference in a residential installation. This equipment generates, uses and can radiate radio frequency energy and, if not installed and used in accordance with the instructions, may cause harmful interference to radio communications. However, there is no guarantee that interference will not occur in a particular installation. If this equipment does cause harmful interference to radio or television reception, which can be determined by turning the equipment off and on, the user is encouraged to try to correct the interference by one or more of the following measures:

- Reorient or relocate the receiving antenna.
- Increase the separation between the equipment and receiver.
- Connect the equipment into an outlet on a circuit different from that to which the receiver is connected.
- Consult the dealer or an experienced radio/TV technician for help.

This device complies with Part 15 of the FCC rules. Operation is subject to the following two conditions:

- (1) this device may not cause harmful interference, and
- (2) this device must accept any interference received, including interference that may cause undesired operation.

### Important information:

Changes or modifications to the equipment not expressly approved by BEHRINGER USA can void the user's authority to use the equipment.



imagine music