



TWS 16 PT

UHF Wireless System

Thomann GmbH

Hans-Thomann-Straße 1

96138 Burgebrach

Germany

Telephone: +49 (0) 9546 9223-0

Internet: www.thomann.de

15.05.2024, ID: 183384, 269808, 273720 (V2)

Table of contents

1	General information.....	5
	1.1 Symbols and signal words.....	5
2	Safety instructions.....	7
3	Features and scope of delivery.....	10
4	Installation and starting up.....	13
	4.1 Receiver.....	14
	4.2 Transmitter.....	16
5	Connections and controls.....	18
	5.1 Receiver.....	18
	5.2 Transmitter.....	22
6	Troubleshooting.....	24
7	Technical specifications.....	26
	7.1 Receiver.....	26
	7.2 Transmitter.....	28
	7.3 Frequency charts.....	30
8	Plug and connection assignment.....	33
9	Protecting the environment.....	35



1 General information

This document contains important instructions for the safe operation of the product. Read and follow the safety instructions and all other instructions. Keep the document for future reference. Make sure that it is available to all those using the product. If you sell the product to another user, be sure that they also receive this document.

Our products and documentation are subject to a process of continuous development. They are therefore subject to change. Please refer to the latest version of the documentation, which is ready for download under www.thomann.de.

1.1 Symbols and signal words

In this section you will find an overview of the meaning of symbols and signal words that are used in this document.

Signal word	Meaning
DANGER!	This combination of symbol and signal word indicates an immediate dangerous situation that will result in death or serious injury if it is not avoided.
NOTICE!	This combination of symbol and signal word indicates a possible dangerous situation that can result in material and environmental damage if it is not avoided.

Warning signs	Type of danger
	Warning – danger zone.

2 Safety instructions

Intended use

This device is intended to be used for the wireless transmission of audio signals from microphones or instruments to amplifiers or active speakers. Use the device only as described in this user manual. Any other use or use under other operating conditions is considered to be improper and may result in personal injury or property damage. No liability will be assumed for damages resulting from improper use.

This device may be used only by persons with sufficient physical, sensorial, and intellectual abilities and having corresponding knowledge and experience. Other persons may use this device only if they are supervised or instructed by a person who is responsible for their safety.

Safety



DANGER!

Risk of injury and choking hazard for children!

Children can suffocate on packaging material and small parts. Children can injure themselves when handling the device. Never allow children to play with the packaging material and the device. Always store packaging material out of the reach of babies and small children. Always dispose of packaging material properly when it is not in use. Never allow children to use the device without supervision. Keep small parts away from children and make sure that the device does not shed any small parts (such knobs) that children could play with.



NOTICE!

Damage to the device if operated in unsuitable ambient conditions!

The device can be damaged if it is operated in unsuitable ambient conditions. Only operate the device indoors within the ambient conditions specified in the “Technical specifications” chapter of this user manual. Avoid operating it in environments with direct sunlight, heavy dirt and strong vibrations. Avoid operating it in environments with strong temperature fluctuations. If temperature fluctuations cannot be avoided (for example after transport in low outside temperatures), do not switch on the device immediately. Never subject the device to liquids or moisture. Never move the device to another location while it is in operation. In environments with increased dirt levels (for example due to dust, smoke, nicotine or mist): Have the device cleaned by qualified specialists at regular intervals to prevent damage due to overheating and other malfunctions.



NOTICE!

Damage to the external power supply due to high voltages!

The device is powered by an external power supply. The external power supply can be damaged if it is operated with the incorrect voltage or if high voltage peaks occur. In the worst case, excess voltages can also cause a risk of injury and fires. Make sure that the voltage specification on the external power supply matches the local power grid before plugging in the power supply. Only operate the external power supply from professionally installed mains sockets that are protected by a residual current circuit breaker (FI). As a precaution, disconnect the power supply from the power grid when storms are approaching or if the device will not be used for a longer period.



NOTICE!

Risk of fire due to incorrect polarity!

Incorrectly inserted batteries may cause fires and destroy the device and the batteries. Observe the markings on the batteries and on the device. Ensure that proper polarity is observed when inserting batteries.



NOTICE!

Possible damage due to leaking batteries!

Batteries can leak and cause permanent damage to the device. Take the batteries out of the device if it is not going to be used for an extended period of time.



NOTICE!

Possible staining due to plasticiser in rubber feet!

The plasticiser contained in the rubber feet of this product may react with the coating of the floor and cause permanent dark stains after some time. If necessary, use a suitable mat or felt slide to prevent direct contact between the device's rubber feet and the floor.

3 Features and scope of delivery

The UHF wireless system TWS 16 PT is particularly suitable for professional audio transmission, for example at events, on rock stages and in concert halls, theatres, musicals or night clubs.

the t.bone TWS 16 PT 863 MHz (item no. 183384)

Your UHF wireless system TWS 16 PT consists of the following components:

- 9.5-inch diversity receiver DS16R
 - Adjustable squelch
 - Two antennas for optimum reception quality
 - Very high sensitivity at very high signal-to-noise ratio
 - Outputs: XLR, 6.35-mm jack socket
 - Mounting in a 9.5-inch rack or (with a second TWS-16 receiver) in a 19-inch rack
 - Power supply: 12 V $\overline{\text{DC}}$ (DC)
- Transmitter: Bodypack
 - Switchable sensitivity (MIC/LINE)
 - 3-pin mini XLR connection (AKG compatible)

Three systems can be operated simultaneously. The system operates in one of 15 switchable channels (in the 863.125 MHz...864.875 MHz range).

Included accessories: 12 V plug-in power supply, mounting material for rack mounting, cable with two 6.35-mm jack plugs, wind shield

**the t.bone TWS 16 PT 600 MHz
(item no. 269808)**

Your UHF wireless system TWS 16 PT consists of the following components:

- 9.5-inch diversity receiver DS16R
 - Adjustable squelch
 - Two antennas for optimum reception quality
 - Very high sensitivity at very high signal-to-noise ratio
 - Outputs: XLR, 6.35-mm jack socket
 - Mounting in a 9.5-inch rack or (with a second TWS-16 receiver) in a 19-inch rack
 - Power supply: 12 V $\overline{\text{DC}}$ (DC)
- Transmitter: Bodypack
 - Switchable sensitivity (MIC/LINE)
 - 3-pin mini XLR connection (AKG compatible)

Three systems can be operated simultaneously. The system operates in one of 16 switchable channels (in the range 606.225 MHz...629.825 MHz). The frequency range is specifically intended for use in Great Britain.

Included accessories: 12 V plug-in power supply, mounting material for rack mounting, cable with two 6.35-mm jack plugs, wind shield

the t.bone TWS 16 PT 821 MHz (item no. 273720)

Your UHF wireless system TWS 16 PT consists of the following components:

- 9.5-inch diversity receiver DS16R
 - Adjustable squelch
 - Two antennas for optimum reception quality
 - Very high sensitivity at very high signal-to-noise ratio
 - Outputs: XLR, 6.35-mm jack socket
 - Mounting in a 9.5-inch rack or (with a second TWS-16 receiver) in a 19-inch rack
 - Power supply: 12 V $\overline{\text{---}}$ (DC)
- Transmitter: Bodypack
 - Switchable sensitivity (MIC/LINE)
 - 3-pin mini XLR connection (AKG compatible)

Four systems can be operated simultaneously. The system operates in one of 16 switchable channels (in the 821.725 MHz...831.450 MHz range).

Included accessories: 12 V plug-in power supply, mounting material for rack mounting, cable with two 6.35-mm jack plugs, wind shield

4 Installation and starting up

Notes on wireless transmission

- This device utilizes frequencies that are not harmonized within the European Union (EU) and therefore may only be used in certain EU member states. In all European countries, the frequencies used for the transmission of audio signals are strictly regulated. Before you start, make sure the frequencies are allowed in the respective country and check whether the operation must be reported to the appropriate authority.
For more information, please visit: <http://www.thomann.de>.
- Make sure that transmitter and receiver are both tuned to the same channel.
- Never set multiple transmitters to the same channel.
- Make sure that there are no metal objects between the transmitter and receiver.
- Avoid interference from other radio or in-ear systems.

4.1 Receiver

Rack mounting

The device is designed for mounting in a standard 9.5-inch rack; it occupies one rack unit (RU). The fixing material required for assembly is included.

Two devices can be mounted side by side in a 19-inch rack. Connect the two devices with the supplied connection brackets as shown in the drawing below.

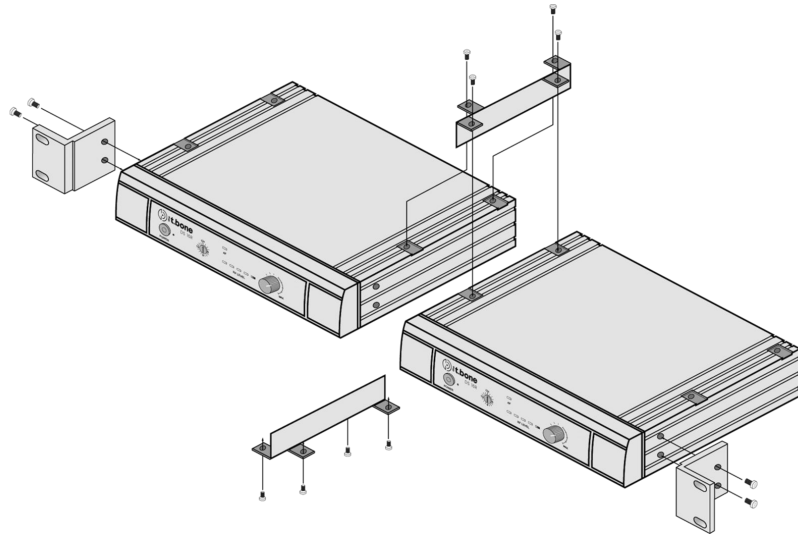

Connecting the power supply



NOTICE!

Damage to the external power supply due to high voltages!

The device is powered by an external power supply. The external power supply can be damaged if it is operated with the incorrect voltage or if high voltage peaks occur. In the worst case, excess voltages can also cause a risk of injury and fires.

Make sure that the voltage specification on the external power supply matches the local power grid before plugging in the power supply.

Only operate the external power supply from professionally installed mains sockets that are protected by a residual current circuit breaker (FI).

As a precaution, disconnect the power supply from the power grid when storms are approaching or if the device will not be used for a longer period.

First, connect the power supply to the receiver and then plug the power supply into the power outlet.

Connecting audio and starting up

Connect one of the audio outputs of the receiver to your mixer or your amplifier. Ensure that only one of the two outputs is ever used at a time, because faults might occur otherwise.

First, set the volume control as follows:

- If you are using a microphone input on your mixer, turn the knob to about 1 o'clock. The audio level on the output sockets is now approximately 77 mV.
- If you are using a line input on your mixer, turn the knob clockwise all the way to the stop. The audio level on the output sockets is now approximately 770 mV.

To get the best sound quality, a fine adjustment of the controller may be required.

4.2 Transmitter

Inserting batteries

Open the lid of the battery compartment by sliding it in the direction of the arrow, and insert the batteries. Pay attention to the correct location of the poles. Close the battery compartment and switch the transmitter on. The *[LOW BATT]* LED lights up briefly.

Connecting a microphone

1. ▶ Make sure that the transmitter is turned off, the main switch is in *[OFF]* position.
2. ▶ Slide the *[MIC/LINE]* switch to the *[MIC]* position.
3. ▶ Adjust the gain to a medium value using the *[GAIN]* control. Use a suitable screwdriver.
4. ▶ Connect the microphone cable to the input of the transmitter.
5. ▶ Turn on the transmitter and check the transmission by using the microphone. If necessary, adjust the gain of the transmitter (with the *[GAIN]* control) and the levels on your mixer or amplifier.

Connecting an instrument

1. ▶ Make sure that the transmitter is turned off, the main switch is in *[OFF]* position.
2. ▶ Slide the *[MIC/LINE]* switch to the *[LINE]* position.
3. ▶ Adjust the gain to a medium value using the *[GAIN]* control. Use a suitable screwdriver.
4. ▶ Connect the instrument cable to the input of the transmitter.
5. ▶ Turn on the transmitter and check the transmission by playing the instrument. If necessary, adjust the gain of the transmitter (with the *[GAIN]* control) and the levels on your mixer or amplifier.

5 Connections and controls

5.1 Receiver

Front panel

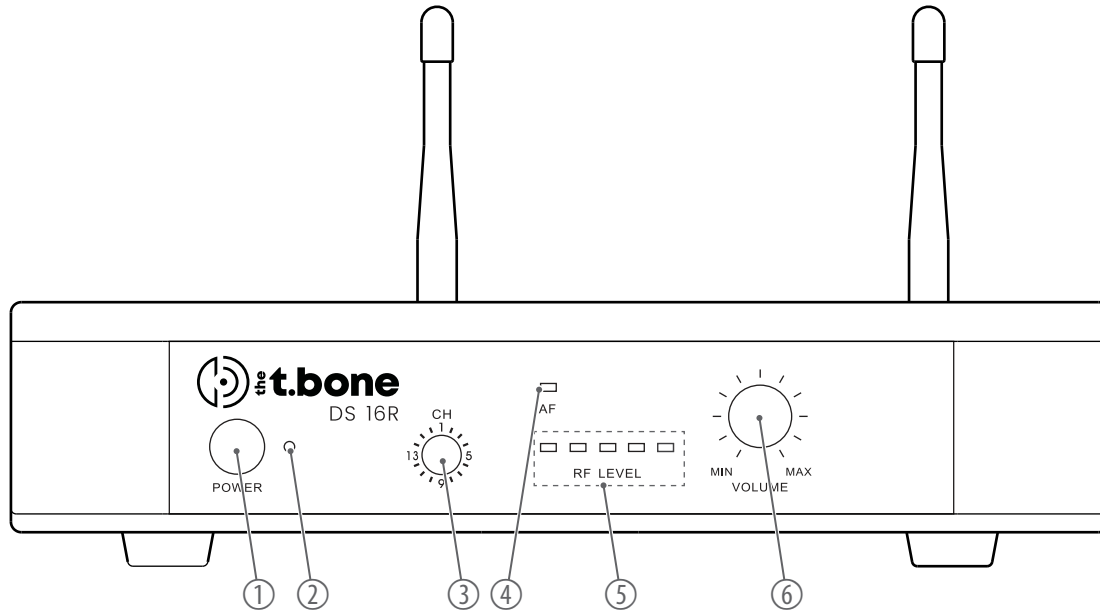

1	<i>[POWER]</i> Main switch. Turns the device on and off.
2	The indicator lights up red when the device is on and ready for operation.
3	<i>[CH]</i> Rotary control for selecting a channel between 1 and 16
4	<i>[AF]</i> The indicator lights up red when an audio signal is received.
5	<i>[RF LEVEL]</i> The LEDs indicate the strength of the received carrier signal. The more LEDs are on, the better the reception. If no LED lights up, no signal is received.
6	<i>[VOLUME]</i> Controls for setting the output level on the two audio outputs on the back

Rear panel

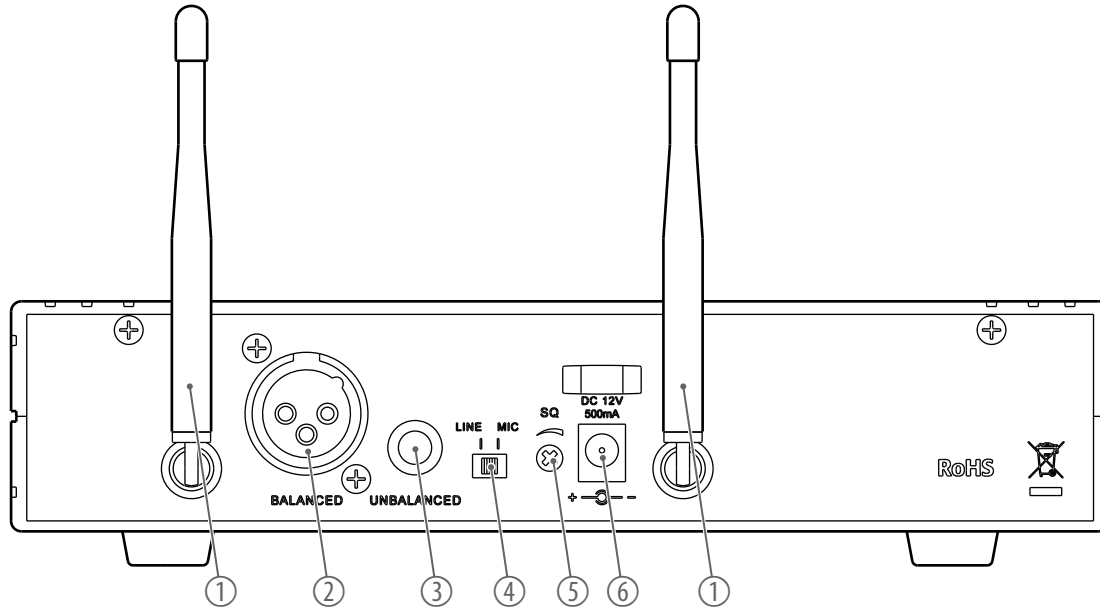

- 1 Tuned UHF antennas. The receiver evaluates the radio signal coming from both antennas and selects the signal with the higher quality for further processing.
- 2 *[AUDIO OUTPUT – BALANCED]* | XLR panel plug as balanced audio signal output for direct connection to a mixer, power amplifier or recording device
- 3 *[AUDIO OUTPUT – UNBALANCED]* | 6.35-mm jack socket as unbalanced audio signal output for direct connection to a mixer, power amplifier or recording device
- 4 *[LINE/MIC]* | Level adjustment switch for the audio outputs. Select the *[LINE]* position when connecting the audio output of the device to a line input and the *[MIC]* position when connecting it to a microphone input.
- 5 *[SQUELCH]* | Squelch. This slider allows you to set the threshold for the squelch. Note: Setting the squelch too high will lower the dynamics of the system.
- 6 *[DC INPUT]* | Socket for connecting the supplied power supply unit. If you are using a different power supply, observe the correct voltage, the polarity of the plug and the power consumption.

5.2 Transmitter

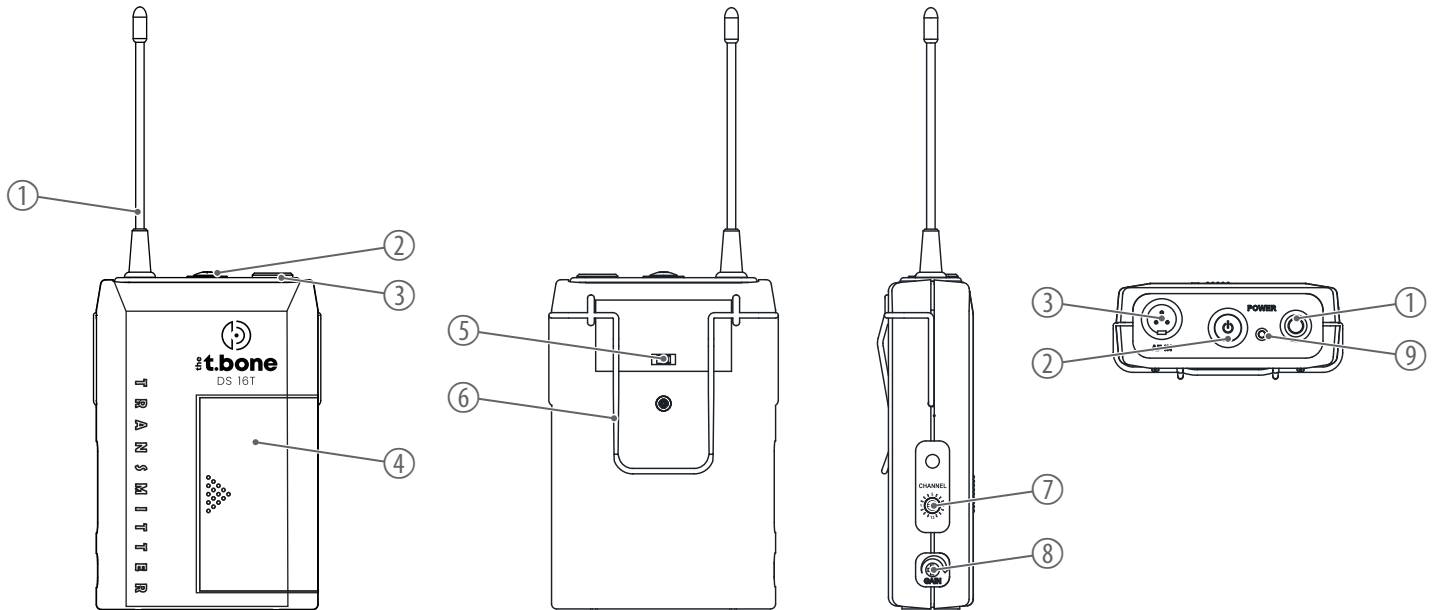

1	Antenna
2	<i>[I/O]</i> Press the switch for several seconds to switch the device on or off.
3	<i>[INPUT]</i> Mini XLR panel plug for connecting a microphone or instrument
4	Battery compartment for two round cell batteries (AA, LR6), 1.5 V or comparable rechargeable batteries
5	<i>[MIC/LINE]</i> Switch for adjusting the input sensitivity to the level of the input signal
6	Retaining clamp
7	<i>[CHANNEL]</i> Rotary control for selecting a channel between 1 and 16
8	<i>[GAIN]</i> Rotary control for adjusting the input sensitivity to the level of the input signal
9	Indicates that the device is switched on and that the battery still provides sufficient power.

6 Troubleshooting

In the following we list a few common problems that may occur during operation. We give you some suggestions for easy troubleshooting:

Symptom	Remedy
No sound	<ol style="list-style-type: none"> 1. Check the power supply of the transmitter and receiver. 2. Make sure that transmitter and receiver are operating in the same frequency range. The frequency range can be found on the devices. 3. Are the transmitter and receiver set to the same channel? 4. Test the connection between the receiver and the connected audio device (amplifier, mixer). Is the connected audio device turned on and does the signal level on the output of the receiver match the input requirements of the audio device? 5. See if the audio transmission works when you move the transmitter closer to the receiver. The "SQUELCH" control may be set too high. 6. Make sure that no metal objects near the transmitter or receiver are obstructing the transmission.
Transmission is interrupted	<ol style="list-style-type: none"> 1. Modify the orientation of the antennas.

Symptom	Remedy
	2. If you are using more than one wireless system at the same time, check the used frequencies and channels.
	3. Interference can also be caused by televisions, radios or mobile phones.
The sound is distorted	Change the "VOLUME" control settings on the receiver.

If the procedures recommended above do not succeed, please contact our Service Center. You can find the contact information at www.thomann.de.

7 Technical specifications

7.1 Receiver

Input connections	Power supply	Power adapter
Output connections	Line output	1× XLR panel plug, balanced
	Tuner output	1× 6.35-mm jack socket, unbalanced
Max. output level adjustment	10 dBV @THD < 1%	
Oscillator	PLL synthesizer, 15 or 16 channels, depending on the version	
Intermediate frequency	1: 243.95 MHz, 2: 10.7 MHz	
Frequency stability	± 0.005%	
Rated frequency deviation	± 20 kHz	
Side and image frequency rejection	80 dB min.	
Sensitivity	8 dBμV	
Antenna gain	2.6 dBi	
Selectivity	> 50 dB	
Pilot tone	32.768 kHz	

NF frequency response	50 Hz...15 kHz (± 3 dB)	
Total harmonic distortion (THD)	< 1%	
Dynamic range	> 96 dB	
Signal-to-noise ratio	> 94 dB, at 20 kHz deviation and 60 dB μ V from the antenna input	
Power supply	External power adapter, 100 - 240 V ~ 50/60 Hz	
Operating voltage	12 V $\overline{\text{---}}$ / 500 mA	
Dimensions (W \times H \times D)	210 mm \times 50 mm \times 189 mm	
Weight	515 g	
Ambient conditions	Temperature range	0 °C...40 °C
	Relative humidity	20%...80% (non-condensing)

The number of systems, frequency band, frequency range, bandwidth and modulation type correspond to those of the transmitter.

7.2 Transmitter

Number of systems that can be operated in parallel	3...4 systems	
Input connections	1 × mini XLR panel plug	
Frequency band	UHF band	
Frequency range	the t.bone TWS 16 PT 863 MHz (item no. 183384)	863.125 MHz ... 864.875 MHz
	the t.bone TWS 16 PT 600 MHz (item no. 269808)	606.225 MHz ... 629.825 MHz
	the t.bone TWS 16 PT 821 MHz (item no. 273720)	821.725 MHz ... 831.450 MHz
Max. transmission power	10 mW	
Maximum input level	Line in	-10 dBV
Bandwidth	the t.bone TWS 16 PT 863 MHz (item no. 183384)	2 MHz
	the t.bone TWS 16 PT 600 MHz (item no. 269808)	24 MHz
	the t.bone TWS 16 PT 821 MHz (item no. 273720)	11 MHz

Modulation type	Frequency modulation (FM)	
Oscillator	PLL synthesizer, 15 or 16 channels, depending on the version	
Input impedance	100 K Ω	
Range in clear field of vision	up to 70 m	
NF frequency response	50 Hz... 15 kHz (± 3 dB)	
Frequency stability	$\pm 0.005\%$	
Rated frequency deviation	± 20 kHz	
Mirror frequency emission	> 60 dB less than the carrier frequency	
Total harmonic distortion	< 1%	
Pilot tone	32.768 kHz	
Battery	Battery type	2 round cell batteries, AA, LR6
	Voltage	1.5 V
	Capacity	65 mA \pm 5 mA
Dimensions (W \times H \times D), without antenna	70 mm \times 96 mm \times 30 mm	
Dimensions (W \times H \times D), with antenna	70 mm \times 190 mm \times 30 mm	
Weight	89 g	

Ambient conditions	Temperature range	0 °C...40 °C
	Relative humidity	20%...80% (non-condensing)

7.3 Frequency charts

the t.bone TWS 16 PT 863 MHz (item no. 183384)

Channel 1	Channel 2	Channel 3	Channel 4	Channel 5	Channel 6	Channel 7	Channel 8
863.125 MHz	863.375 MHz	863.625 MHz	864.000 MHz	864.250 MHz	864.500 MHz	864.750 MHz	864.875 MHz

Channel 9	Channel 10	Channel 11	Channel 12	Channel 13	Channel 14	Channel 15
863.250 MHz	863.500 MHz	863.750 MHz	864.125 MHz	864.375 MHz	864.625 MHz	864.875 MHz

**the t.bone TWS 16 PT 600 MHz
(item no. 269808)**

Channel 1	Channel 2	Channel 3	Channel 4	Channel 5	Channel 6	Channel 7	Channel 8
606.225 MHz	607.225 MHz	609.625 MHz	610.225 MHz	611.025 MHz	611.625 MHz	615.025 MHz	619.225 MHz

Channel 9	Channel 10	Channel 11	Channel 12	Channel 13	Channel 14	Channel 15	Channel 16
619.625 MHz	621.225 MHz	621.625 MHz	624.825 MHz	625.425 MHz	627.225 MHz	628.625 MHz	629.825 MHz

**the t.bone TWS 16 PT 821 MHz
(item no. 273720)**

Channel 1	Channel 2	Channel 3	Channel 4	Channel 5	Channel 6	Channel 7	Channel 8
821.725 MHz	822.250 MHz	822.925 MHz	823.375 MHz	823.950 MHz	824.850 MHz	825.450 MHz	826.525 MHz

Channel 9	Channel 10	Channel 11	Channel 12	Channel 13	Channel 14	Channel 15	Channel 16
827.300 MHz	827.825 MHz	828.525 MHz	828.925 MHz	829.475 MHz	829.875 MHz	830.975 MHz	831.450 MHz

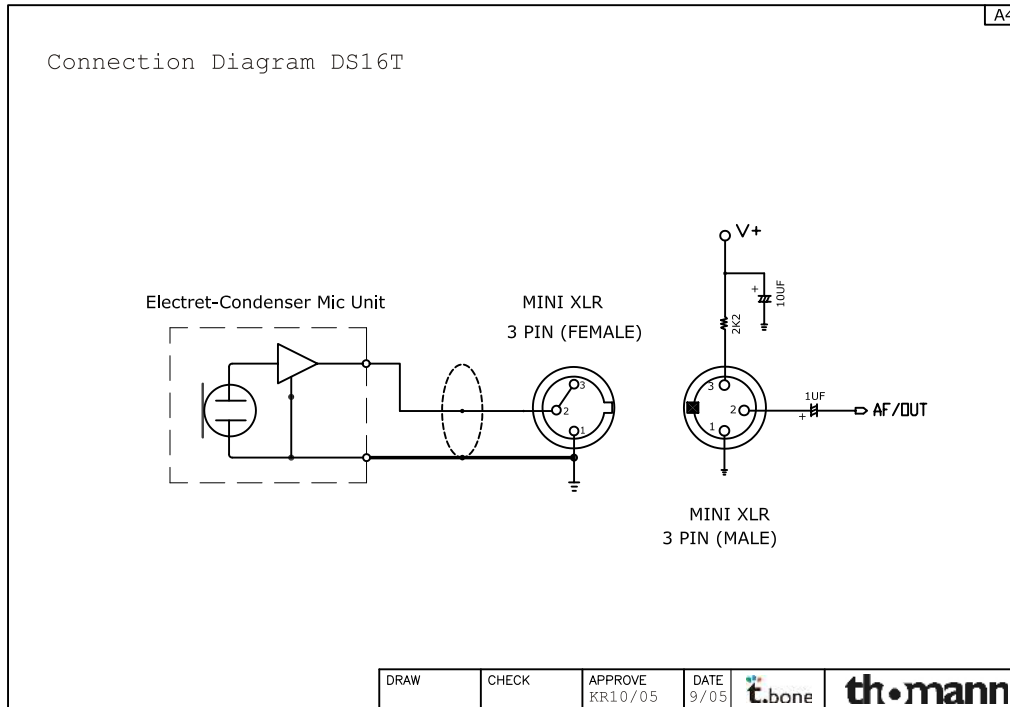

8 Plug and connection assignment

Unpack and check carefully there is no transportation damage before using the unit. Keep the equipment packaging. To fully protect the product against vibration, dust and moisture during transportation or storage use the original packaging or your own packaging material suitable for transport or storage, respectively.

Create all connections while the device is off. Use the shortest possible high-quality cables for all connections. Take care when running the cables to prevent tripping hazards.

1/4" TS phone plug (mono, unbalanced)



1	Signal
2	Ground, shielding

XLR plug (balanced)

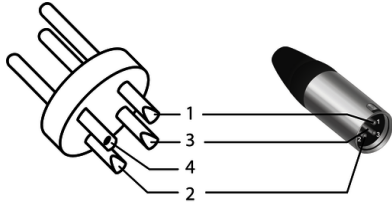

1	Ground, shielding
2	Signal (in phase, +)
3	Signal (out of phase, -)
4	Shielding on plug housing (option)

Mini XLR



1	Ground
2	Positive signal (+)
3	Negative signal (-)

9 Protecting the environment

Disposal of the packing material

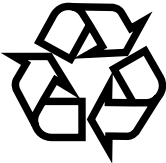

Environmentally friendly materials have been chosen for the packaging. These materials can be sent for normal recycling. Ensure that plastic bags, packaging, etc. are disposed of in the proper manner.

Do not dispose of these materials with your normal household waste, but make sure that they are collected for recycling. Please follow the instructions and markings on the packaging.

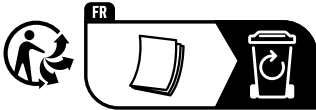

Observe the disposal note regarding documentation in France.

Disposal of batteries



Batteries must not be thrown away or burnt, but must instead be disposed of in line with the local regulations on the disposal of hazardous waste. Use the available collection sites.

Before disposing of your old device, remove the batteries if this is possible without destroying it.

Dispose of the batteries or rechargeable batteries at suitable collection points or through your local waste facility.

Disposal of your old device

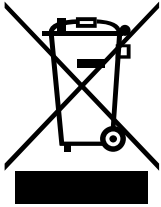

This product is subject to the European Waste Electrical and Electronic Equipment Directive (WEEE) as amended.

Do not dispose of your old device with your normal household waste; instead, deliver it for controlled disposal by an approved waste disposal firm or through your local waste facility. If in doubt, consult your local waste management facility. You can also return the device to a retailer if they offer to take the device back for free or if they are legally obliged to do so. When disposing of the device, comply with the rules and regulations that apply in your country. You can also return your old device to Thomann GmbH at no charge. Check the current conditions on www.thomann.de.

Proper disposal protects the environment as well as the health of your fellow human beings. This is because the proper handling of old devices negates the potential negative effects of hazardous substances, and because it conserves resources by recycling them.

Also note that waste avoidance is a valuable contribution to environmental protection. Repairing a device or passing it on to another user is an ecologically valuable alternative to disposal.

If your old device contains personal data, delete those data before disposing of it.

