



STAIRVILLE

JunoScan MK-II
LED-scanner

Musikhaus Thomann
Thomann GmbH
Hans-Thomann-Straße 1
96138 Burgebrach
Deutschland
Telephone: +49 (0) 9546 9223-0
E-mail: info@thomann.de
Internet: www.thomann.de

10.01.2018, ID: 271626 (V3)

Table of contents

1	General notes	5
	1.1 Further information.....	6
	1.2 Notational conventions.....	7
	1.3 Symbols and signal words.....	8
2	Safety instructions	10
3	Features	16
4	Installation	17
5	Setup	19
6	Connections and controls	22
7	Operation	27
	7.1 Starting up the device.....	27
	7.2 Main menu.....	28
	7.3 Settings menu.....	34
	7.4 Gobos.....	37
	7.5 Functions in 5-channel DMX mode.....	39

	7.6 Functions in 8-channel DMX mode.....	43
8	Technical data.....	51
9	Plug and connection assignments.....	52
10	Troubleshooting.....	53
11	Cleaning.....	55
12	Protecting the environment.....	56

1 General notes

This manual contains important instructions for the safe operation of the unit. Read and follow the safety instructions and all other instructions. Keep the manual for future reference. Make sure that it is available to all those using the device. If you sell the unit please make sure that the buyer also receives this manual.

Our products are subject to a process of continuous development. Thus, they are subject to change.

1.1 Further information

On our website (www.thomann.de) you will find lots of further information and details on the following points:

Download	This manual is also available as PDF file for you to download.
Keyword search	Use the search function in the electronic version to find the topics of interest for you quickly.
Online guides	Our online guides provide detailed information on technical basics and terms.
Personal consultation	For personal consultation please contact our technical hotline.
Service	If you have any problems with the device the customer service will gladly assist you.

1.2 Notational conventions

This manual uses the following notational conventions:

Letterings

The letterings for connectors and controls are marked by square brackets and italics.

Examples: *[VOLUME]* control, *[Mono]* button.

Displays

Texts and values displayed on the device are marked by quotation marks and italics.

Examples: *'24ch'*, *'OFF'*.

Cross-references





References to other locations in this manual are identified by an arrow and the specified page number. In the electronic version of the manual, you can click the cross-reference to jump to the specified location.

Example: See  *'Cross-references'* on page 7.

1.3 Symbols and signal words

In this section you will find an overview of the meaning of symbols and signal words that are used in this manual.

Signal word	Meaning
DANGER!	This combination of symbol and signal word indicates an immediate dangerous situation that will result in death or serious injury if it is not avoided.
WARNING!	This combination of symbol and signal word indicates a possible dangerous situation that can result in death or serious injury if it is not avoided.
CAUTION!	This combination of symbol and signal word indicates a possible dangerous situation that can result in minor injury if it is not avoided.
NOTICE!	This combination of symbol and signal word indicates a possible dangerous situation that can result in material and environmental damage if it is not avoided.

Warning signs	Type of danger
	Warning – high-voltage.
	Warning – hot surface.
	Warning – dangerous optical radiation.
	Warning – suspended load.
	Warning – danger zone.

2 Safety instructions

Intended use

This device is intended for use as a multifunctional lighting instrument with movable mirror. The device is designed for professional use and is not suitable for use in households. Use the device only as described in this user manual. Any other use or use under other operating conditions is considered to be improper and may result in personal injury or property damage. No liability will be assumed for damages resulting from improper use.

This device may be used only by persons with sufficient physical, sensorial, and intellectual abilities and having corresponding knowledge and experience. Other persons may use this device only if they are supervised or instructed by a person who is responsible for their safety.

Safety**DANGER!****Danger for children**

Ensure that plastic bags, packaging, etc. are disposed of properly and are not within reach of babies and young children. Choking hazard!

Ensure that children do not detach any small parts (e.g. knobs or the like) from the unit. They could swallow the pieces and choke!

Never let children unattended use electrical devices.

**DANGER!****Electric shock caused by high voltages inside**

Within the device there are areas where high voltages may be present. Never remove any covers.

There are no user-serviceable parts inside.

Do not use the device if covers, protectors or optical components are missing or damaged.



DANGER!

Electric shock caused by short-circuit

Always use proper ready-made insulated mains cabling (power cord) with a protective contact plug. Do not modify the mains cable or the plug. Failure to do so could result in electric shock/death or fire. If in doubt, seek advice from a registered electrician.



WARNING!

Eye damage caused by high light intensity

The lamp used in this device produces an intense beam of visible and invisible light radiation.

Do not start the operation of the device without completely fixed covers. Never look directly into the light source.



WARNING!

Risk of epileptic shock

Strobe lighting can trigger seizures in photosensitive epilepsy. Sensitive persons should avoid looking at strobe lights.



WARNING!

Risk of burns

The surface of the device can become very hot during operation.

Do not touch the device with bare hands during operation, and after switching off wait for at least 15 minutes.



CAUTION!

Risk of injury due to mirror movements

The mirror mounted at the device head may perform very fast movements (pan, tilt) and reflect very bright light. This is also the case immediately after switching on the device, with automatic or remote operation, and while a connected DMX controller is in off state. Persons who are in the immediate vicinity of the device may be injured or frightened by this.

Make sure that there are no obstacles within the movement range of the mirror, and that no persons are in the immediate vicinity of the device before switching it on and during its operation. If any work is to be carried out within the movement range or in the immediate vicinity of the mirror, the device must remain switched off.



NOTICE!

Risk of fire

Do not cover the device nor any ventilation slots. Do not place the device near any direct heat source. Keep the device away from naked flames.



NOTICE!

Operating conditions

This device has been designed for indoor use only. To prevent damage, never expose the device to any liquid or moisture. Avoid direct sunlight, heavy dirt, and strong vibrations.



NOTICE!

Power supply

Before connecting the device, ensure that the input voltage (AC outlet) matches the voltage rating of the device and that the AC outlet is protected by a residual current circuit breaker. Failure to do so could result in damage to the device and possibly injure the user.

Unplug the device before electrical storms occur and when it is unused for long periods of time to reduce the risk of electric shock or fire.

3 Features

The LED scanner is especially suited for professional lighting tasks, e.g. during events, on rock music stages, in theatre and musical productions or in discotheques.

Special features of this device:

- White high-power LED (10 W)
- Control via DMX (5 or 8 channels) and buttons plus display on the unit itself.
- Built-in automatic show programmes
- Sound control
- Master/slave mode
- Colour wheel with 9 colours plus white, rainbow effect
- Gobo wheel: 9 gobos plus open
- Gobo shake function
- Shutter for strobe effect
- Electronic dimmer

4 Installation

Unpack and carefully check that there is no transportation damage before using the unit. Keep the equipment packaging. To fully protect the device against vibration, dust and moisture during transportation or storage use the original packaging or your own packaging material suitable for transport or storage, respectively.

You can install the device standing or hanging. When in use, the device must be mounted at a solid surface or clamped to an approved truss.

Work from a stable platform whenever you install or move the device or when you perform any kind of maintenance. Block access under the work area.



WARNING!

Risk of injury caused by falling objects

Make sure that the installation complies with the standards and rules that apply in your country. Always secure the device with a secondary safety attachment, such as a safety cable or a safety chain.



NOTICE!

Risk of overheating

Always ensure sufficient ventilation.

The ambient temperature must always be below 40 °C (104 °F).



NOTICE!

Possible data transmission errors

For error-free operation make use of dedicated DMX cables and do not use ordinary microphone cables.

Never connect the DMX input or output to audio devices such as mixers or amplifiers.

Mounting options

The adjustable suspension is used for secure mounting. There, you can fasten adapters such as half couplers, trigger clamps, c-hooks etc. The safety cable must be routed through the safety eyelet on the top of the device (↪ *Chapter 6 'Connections and controls' on page 22*).

5 Setup

Establish all connections as long as the unit is switched off. Use the shortest possible high-quality cables for all connections.

Connections in DMX mode

Connect the DMX input of the device to the DMX output of a DMX controller or another DMX device. Connect the output of the first DMX device to the input of the second one, and so on to form a daisy chain. Always ensure that the output of the last DMX device in the daisy chain is terminated with a resistor ($110\ \Omega$, $\frac{1}{4}\text{ W}$).

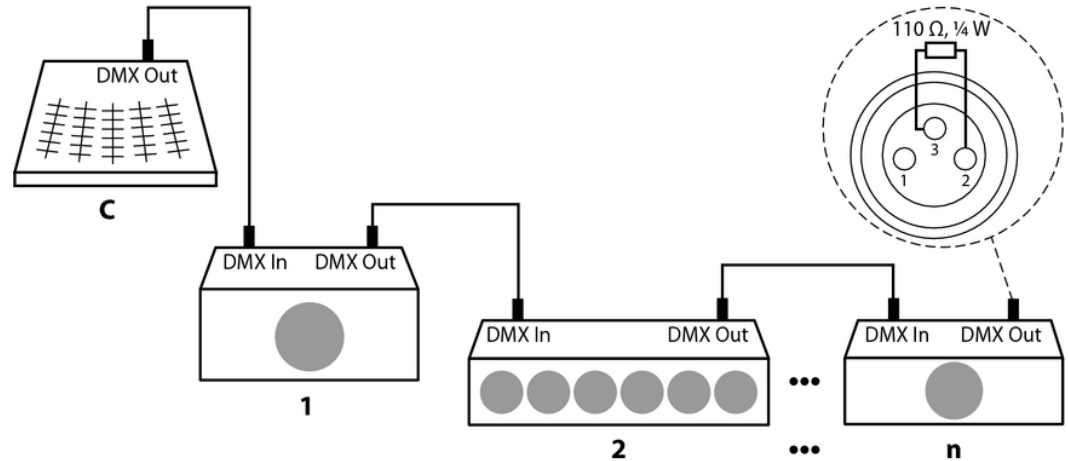

DMX indicator

While the device and the DMX controller are in operation, a flashing white rectangle (DMX indicator) in the display shows that a DMX signal is present at the input.

Connections in master/slave mode

When you configure a group of devices in master/slave mode, the first unit will control the other units for an automatic, sound-activated, synchronized show. This function is ideal when you want to start a show immediately. Connect the DMX output of the master device to the DMX input of the first slave device. Then connect the DMX output of the first slave device to the DMX input of the second slave device and so on.

6 Connections and controls

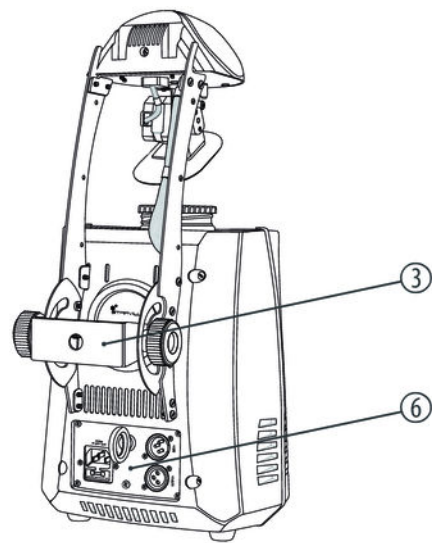
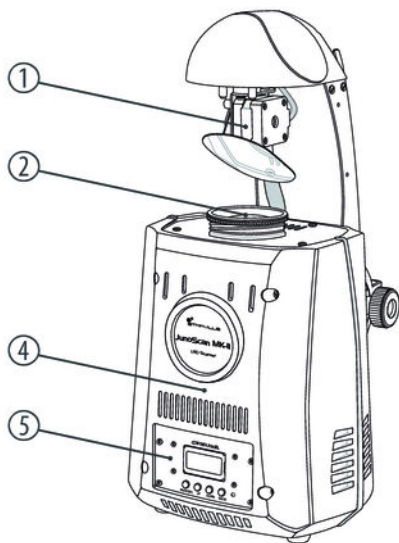

1	Device head with movable mirror.
2	Lens, manual focussing.
3	Adjustable suspension.
4	Device body.
5	Control panel.
6	Connections.

Control panel

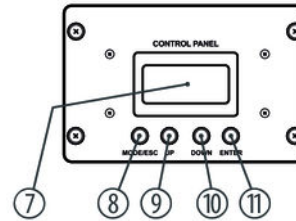

7	Display.
8	[MODE ESC] button. Activates the main menu and toggles between menu items. Closes an open sub-menu without saving the changes.
9	[UP] button. Increments the displayed value by one.

10	<i>[DOWN]</i> button. Decrements the displayed value by one.
11	<i>[ENTER]</i> button. Selects an option in the corresponding mode, confirms the set value.

Connections

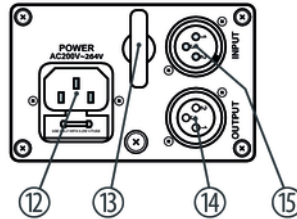

12 Plug for mains cable with fuse holder.

13 Eyelet for safety cable.

14 *[OUTPUT]*
DMX output.

15 *[INPUT]*
DMX input.

7 Operation

7.1 Starting up the device



CAUTION!

Risk of injury due to mirror movements

The mirror mounted at the device head may perform very fast movements (pan, tilt) and reflect very bright light. This is also the case immediately after switching on the device, with automatic or remote operation, and while a connected DMX controller is in off state. Persons who are in the immediate vicinity of the device may be injured or frightened by this.

Make sure that there are no obstacles within the movement range of the mirror, and that no persons are in the immediate vicinity of the device before switching it on and during its operation. If any work is to be carried out within the movement range or in the immediate vicinity of the mirror, the device must remain switched off.

To start up the device, connect it to the mains. After a few seconds, the fans start to work, the mirror at the device head moves to the pan and tilt home positions and the display indicates a system reset. After a few more seconds, the device starts to operate in the most recently set mode.

7.2 Main menu

Briefly press the *[MODE ESC]* button to activate the main menu. Use the *[MODE ESC]* button to move to the next menu item.

All previously made settings are saved, even if you disconnect the device from the power supply. To restart with the default values, use the *'Reset'* function (↪ *'General reset'* on page 32).

Auto show mode

Press the *[MODE ESC]* button repeatedly until 'AutoMode' appears in the first line of the display. You may now choose an operating mode with the *[UP]* and *[DOWN]* buttons:

Displayed text when menu is open	Displayed text after confirming with <i>[ENTER]</i>	Operating mode
'AutoMode' 'Mast_SR'	'AutoMode' 'SRUN'	Sound-controlled show in stand-alone mode or as a master in master/slave mode
'AutoMode' 'Mast_FA'	'AutoMode' 'FAST'	Automatic fast show in stand-alone mode or as a master in master/slave mode
'AutoMode' 'Mast_SL'	'AutoMode' 'SLOW'	Automatic slow show in stand-alone mode or as a master in master/slave mode
'AutoMode' 'SLAVE'	'AutoMode' 'SON'	The device works as a slave, following the sequence of actions on the master unit

Once the display shows the desired option, press the *[ENTER]* button to confirm your setting and to close the menu. To close the menu without saving the changes, press the *[MODE ESC]* button or wait one minute.

DMX mode, DMX address

Press the *[MODE ESC]* button repeatedly until 'DmxMode' appears in the first line of the display. You can now set the number of the first DMX channel used by the device (DMX address). Use the *[UP]* and *[DOWN]* buttons to select a value between 1 and 512.

Once the display shows the desired option, press the *[ENTER]* button to confirm your setting and to close the menu. To close the menu without saving the changes, press the *[MODE ESC]* button or wait one minute.

Make sure that the DMX address matches the configuration of your DMX controller. The following table shows the highest usable DMX address for the different DMX modes.

Mode	Highest usable DMX address
5 channels	508
8 channels	505

Reversal of pan direction

Press the *[MODE ESC]* button repeatedly until *'PanDirt'* appears in the first line of the display. Use the *[UP]* and *[DOWN]* buttons to choose between *'forward'* (normal pan direction) and *'reverse'* (reverse pan direction).

Press the *[ENTER]* button to confirm your setting and to close the menu. To close the menu without saving the changes, press the *[MODE ESC]* button or wait one minute.

Reversal of tilt direction

Press the *[MODE ESC]* button repeatedly until *'TilDirt'* appears in the first line of the display. Use the *[UP]* and *[DOWN]* buttons to choose between *'forward'* (normal tilt direction) and *'reverse'* (reverse tilt direction).

Press the *[ENTER]* button to confirm your setting and to close the menu. To close the menu without saving the changes, press the *[MODE ESC]* button or wait one minute.

DMX mode

Press the *[MODE ESC]* button repeatedly until *'Channel'* appears in the first line of the display. Use the *[UP]* and *[DOWN]* buttons to select one of the following DMX modes: 5-channel or 8-channel mode. This setting takes effect only when the device is operated under DMX control.

Press the *[ENTER]* button to confirm your setting and to close the menu. To close the menu without saving the changes, press the *[MODE ESC]* button or wait one minute.

Resetting the stepper motors

This function allows you to return the stepper motors to their home positions (mechanical reset).

Press the *[MODE ESC]* button repeatedly until *'Rest'* appears in the first line of the display.

Press the *[ENTER]* button. The device performs a reset.

General reset

This function allows you to restore the factory settings of all parameters that can be changed in the main menu.

Press the *[MODE ESC]* button repeatedly until *'Load'* appears in the first line of the display.

Press the *[ENTER]* button. The device performs a reset.

Overview (main menu)

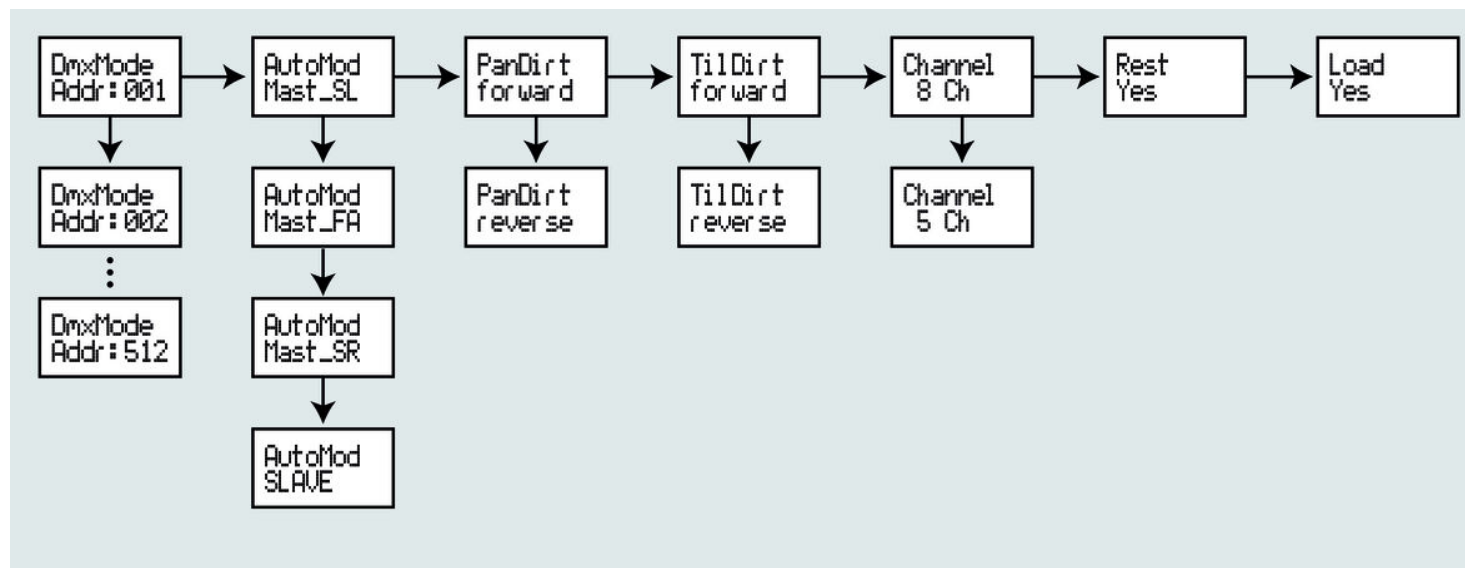

7.3 Settings menu

Press and hold down the *[MODE ESC]* button for approx. five seconds to activate the settings menu. Use the *[UP]* and *[DOWN]* buttons to enter the device password 2323. The *[UP]* button modifies the digit at the cursor position, while the *[DOWN]* button moves the cursor to the next digit. Once you have entered all digits, press the *[ENTER]* button.

To close the settings menu and return to the main menu, press the *[MODE ESC]* button for approx. five seconds.

All previously made settings are saved, even if you disconnect the device from the power supply.



There is no reset function for the parameters that can be changed in the settings menu.

Adjusting the gobo wheel starting position

Activate the settings menu. Press the *[MODE ESC]* button repeatedly until 'GOBO' appears in the first line of the display. Use the *[UP]* and *[DOWN]* buttons to select a value between 0 and 255 until the gobo wheel is in the desired starting position.

Press the *[ENTER]* button to confirm your setting and to move to the next menu option. To close the menu without saving the changes, press the *[MODE ESC]* button or wait one minute.

Adjusting the colour wheel starting position

Activate the settings menu. Press the *[MODE ESC]* button repeatedly until 'COLOR' appears in the first line of the display. Use the *[UP]* and *[DOWN]* buttons to select a value between 0 and 255 until the colour wheel is in the desired starting position.

Press the *[ENTER]* button to confirm your setting and to move to the next menu option. To close the menu without saving the changes, press the *[MODE ESC]* button or wait one minute.

LED setting

This function is only needed for technical service and should not be used during normal operation.

Activate the settings menu. Press the *[MODE ESC]* button repeatedly until 'LED' appears in the first line of the display. Use the *[UP]* and *[DOWN]* buttons to select a value between 0 and 70.

Press the *[ENTER]* button to confirm your setting and to move to the next menu option. To close the menu without saving the changes, press the *[MODE ESC]* button or wait one minute.

Overview (settings menu)

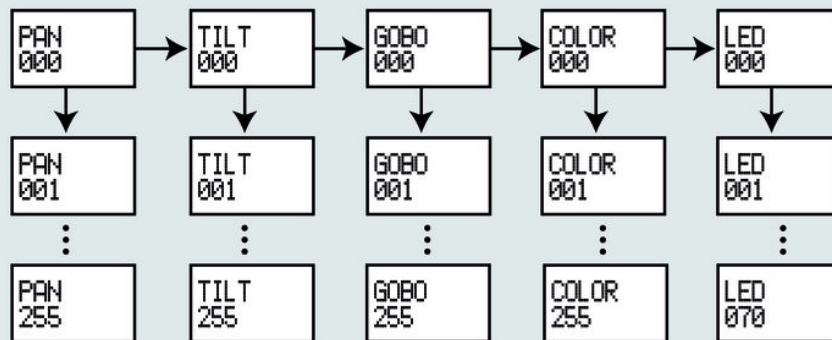



There is no setting function available for PAN and TILT.

7.4 Gobos

The following figure shows the available gobos and their numbers.

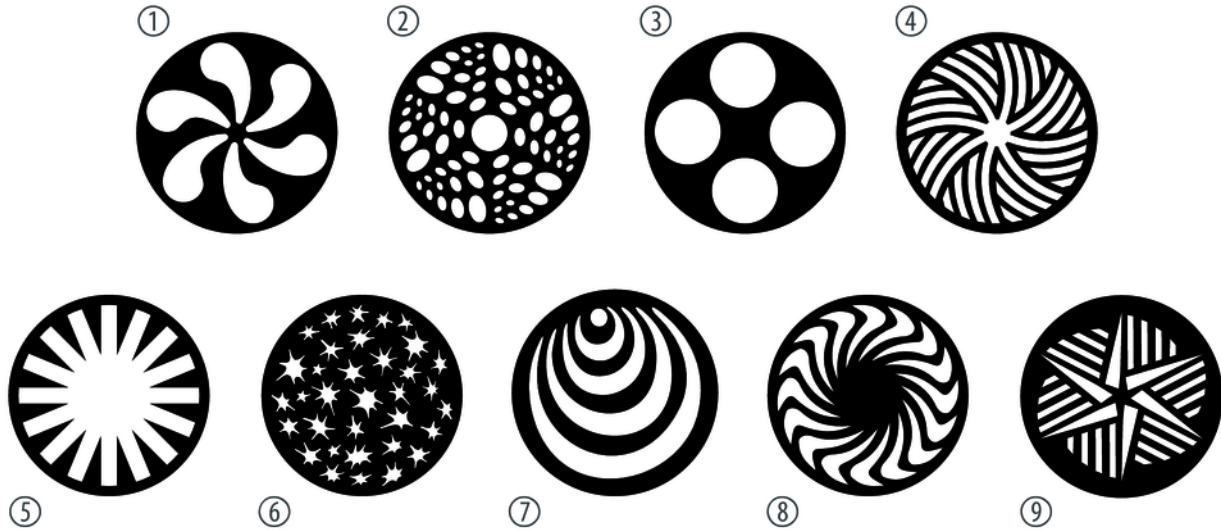

7.5 Functions in 5-channel DMX mode

Channel	Value	Function
1	0...255	Pan (0° to 180°)
2	0...255	Tilt (0° to 60°)
3	Colour wheel	
	0...5	White
	6...11	Yellow
	12...17	Pink
	18...23	Green
	24...29	Red
	30...35	Blue
	36...41	Orange
	42...47	Dark blue

Channel	Value	Function
	48...53	Kelly green
	54...63	Orange red
	64...73	White + yellow
	74...79	Yellow + pink
	80...85	Pink + green
	86...91	Green + red
	92...97	Red + blue
	98...103	Blue + orange
	104...109	Orange + dark blue
	110...115	Ark blue + Kelly green
	116...121	Kelly green + orange red
	122...127	Orange red + white
	128...191	Rainbow effect in positive rotation direction, with increasing speed

Channel	Value	Function
	192...255	Rainbow effect in negative rotation direction, with increasing speed
4	Shutter	
	0...3	Closed (blackout)
	4...7	Open
	8...215	Strobe effect with increasing speed
	216...255	Open
5	Gobo wheel	
	0...5	Open
	6...11	Gobo 1
	12...17	Gobo 2
	18...23	Gobo 3
	24...29	Gobo 4
	30...35	Gobo 5

Channel	Value	Function
	36...41	Gobo 6
	42...47	Gobo 7
	48...53	Gobo 8
	54...63	Gobo 9
	64...73	Gobo 9 shake
	74...79	Gobo 8 shake
	80...85	Gobo 7 shake
	86...91	Gobo 6 shake
	92...97	Gobo 5 shake
	98...103	Gobo 4 shake
	104...109	Gobo 3 shake
	110...115	Gobo 2 shake
	116...121	Gobo 1 shake

Channel	Value	Function
	122...127	Open
	128...191	Rainbow effect in positive rotation direction, with increasing speed
	192...255	Rainbow effect in negative rotation direction, with increasing speed

7.6 Functions in 8-channel DMX mode

Channel	Value	Function
1	0...255	Pan (0° to 180°)
2	0...255	Tilt (0° to 60°)
3	Colour wheel	
	0...5	White
	6...11	Yellow

Channel	Value	Function
	12...17	Pink
	18...23	Green
	24...29	Red
	30...35	Blue
	36...41	Orange
	42...47	Dark blue
	48...53	Kelly green
	54...63	Orange red
	64...73	White + yellow
	74...79	Yellow + pink
	80...85	Pink + green
	86...91	Green + red
	92...97	Red + blue

Channel	Value	Function
	98...103	Blue + orange
	104...109	Orange + dark blue
	110...115	Ark blue + Kelly green
	116...121	Kelly green + orange red
	122...127	Orange red + white
	128...191	Rainbow effect in positive rotation direction, with increasing speed
	192...255	Rainbow effect in negative rotation direction, with increasing speed
4	Shutter	
	0...3	Closed (blackout)
	4...7	Open
	8...215	Strobe effect with increasing speed
	216...255	Open
5	0...255	Electronic dimmer (0 to 100 %)

Channel	Value	Function
6	Gobo wheel	
	0...5	Open
	6...11	Gobo 1
	12...17	Gobo 2
	18...23	Gobo 3
	24...29	Gobo 4
	30...35	Gobo 5
	36...41	Gobo 6
	42...47	Gobo 7
	48...53	Gobo 8
	54...63	Gobo 9
	64...73	Gobo 9 shake
74...79	Gobo 8 shake	

Channel	Value	Function
	80...85	Gobo 7 shake
	86...91	Gobo 6 shake
	92...97	Gobo 5 shake
	98...103	Gobo 4 shake
	104...109	Gobo 3 shake
	110...115	Gobo 2 shake
	116...121	Gobo 1 shake
	122...127	Open
	128...191	Rainbow effect in positive rotation direction, with increasing speed
	192...255	Rainbow effect in negative rotation direction, with increasing speed
7		
	0...7	Reserved
	8...15	Blackout during pan and tilt movement

Channel	Value	Function
	16...23	Blackout during colour wheel movement
	24...31	Blackout during gobo wheel movement
	32...39	No blackout during colour wheel movement nor during pan and tilt movement
	40...47	No blackout during gobo wheel movement nor during pan and tilt movement
	48...55	No blackout during colour wheel movement nor during gobo wheel movement nor during pan and tilt movement
	56...95	Reserved
	96...103	Reset pan angle
	104...111	Reset tilt angle
	112...119	Reset colour wheel
	120...127	Reset gobo wheel
	128...151	Reserved
	152...159	Reset all channels

Channel	Value	Function
	160...255	Reserved
8	Built-in programmes	
	0...7	Reserved
	8...23	Programme 1
	24...39	Programme 2
	40...55	Programme 3
	56...71	Programme 4
	72...87	Programme 5
	88...103	Programme 6
	104...119	Programme 7
	120...135	Programme 8
	136...151	Sound control 1
	152...167	Sound control 2

Channel	Value	Function
	168...183	Sound control 3
	184...199	Sound control 4
	200...215	Sound control 5
	216...231	Sound control 6
	232...247	Sound control 7
	248...255	Sound control 8

8 Technical data

Number of DMX channels	5 or 8 channels, depending on operating mode
Lamp	LED (1 × 10 W, white)
Maximum pan angle	180°
Maximum tilt angle	60°
Dimmer	electronic, 0 ... 100 %
Voltage supply	230 V ~ 50 Hz
Power consumption	57 W
Fuse	5 mm × 20 mm, 2.0 A, 250 V, fast-blow
Dimensions (W × D × H, with bracket)	240 mm × 477 mm × 259 mm
Weight	4.3 kg

9 Plug and connection assignments

Introduction

This chapter will help you select the right cables and plugs to connect your valuable equipment so that a perfect light experience is guaranteed.

Please take our tips, because especially in 'Sound & Light' caution is indicated: Even if a plug fits into a socket, the result of an incorrect connection may be a destroyed DMX controller, a short circuit or 'just' a not working light show!

DMX connections

The unit offers a 3-pin XLR socket for DMX output and a 3-pin XLR plug for DMX input. Please refer to the drawing and table below for the pin assignment of a suitable XLR plug.



Pin	Configuration
1	Ground, shielding
2	Signal inverted (DMX-, 'cold signal')
3	Signal (DMX+, 'hot signal')

10 Troubleshooting



NOTICE!

Possible data transmission errors

For error-free operation make use of dedicated DMX cables and do not use ordinary microphone cables.

Never connect the DMX input or output to audio devices such as mixers or amplifiers.

In the following we list a few common problems that may occur during operation. We give you some suggestions for easy troubleshooting:

Symptom	Remedy
Device not working, no light, fan not working	Check mains connection and fuse.
Not responding to DMX controller	1. The DMX indicator in the display should flash during data transmission. If not, check DMX connectors and cables for proper matching and fit.
	2. If the DMX indicator in the display is lit and there is no response, check address settings and DMX polarity.
	3. Try using another DMX controller.
	4. Check whether the DMX cables run near or parallel to high-voltage cables that may cause damage or interference to the DMX interface circuit.

If the procedures recommended above do not succeed, please contact our Service Center. You can find the contact information at www.thomann.de.

11 Cleaning

Optical lenses and mirrors

Clean the optical lenses and mirrors which are accessible from the outside periodically to optimise light output. The cleaning frequency depends on the operating environment: damp, smoky or particularly dirty environments can cause greater accumulation of dirt on the unit's optics.

- Clean with a soft cloth using our lamp and lens cleaner (item no. 280122).
- Always wipe dry the parts carefully.

Fan grids

The fan grids of the device must be cleaned on a regular basis to remove dust and dirt. Before cleaning, switch off the device and disconnect AC-powered devices from the mains. Use a lint-free damp cloth for cleaning. Never use solvents or alcohol for cleaning.

12 Protecting the environment

Disposal of the packaging material



For the transport and protective packaging, environmentally friendly materials have been chosen that can be supplied to normal recycling.

Ensure that plastic bags, packaging, etc. are properly disposed of.

Do not just dispose of these materials with your normal household waste, but make sure that they are collected for recycling. Please follow the notes and markings on the packaging.

Disposal of your old device



This product is subject to the European Waste Electrical and Electronic Equipment Directive (WEEE). Do not dispose with your normal household waste.

Dispose of this device through an approved waste disposal firm or through your local waste facility. When discarding the device, comply with the rules and regulations that apply in your country. If in doubt, consult your local waste disposal facility.



Musikhaus Thomann · Hans-Thomann-Straße 1 · 96138 Burgebrach · Germany · www.thomann.de