

STARVILLE

STAGE-PAR
CX-2 RGBAW
LED PAR

Musikhaus Thomann
Thomann GmbH
Hans-Thomann-Straße 1
96138 Burgebrach
Germany
Telephone: +49 (0) 9546 9223-0
E-mail: info@thomann.de
Internet: www.thomann.de

19.02.2016, ID: 281412 (V2)

Table of contents

1	General notes	5
	1.1 Further information.....	6
	1.2 Notational conventions.....	7
	1.3 Symbols and signal words.....	7
2	Safety instructions	10
3	Features	15
4	Installation	16
5	Starting up	20
6	Connections and controls	23
7	Operating	26
	7.1 Starting up the device.....	26
	7.2 Main menu.....	26
	7.3 Menu overview.....	33
	7.4 Functions im 3-channel DMX mode.....	34
	7.5 Functions im 5-channel DMX mode.....	34

7.6	Functions im 7-channel DMX mode.....	35
7.7	Functions im 8-channel DMX mode.....	36
8	Technical data.....	38
9	Plug and connection assignments.....	39
10	Troubleshooting.....	40
11	Cleaning.....	42
12	Protecting the environment.....	43

1 General notes

This manual contains important instructions for the safe operation of the unit. Read and follow the safety instructions and all other instructions. Keep the manual for future reference. Make sure that it is available to all those using the device. If you sell the unit please make sure that the buyer also receives this manual.

Our products are subject to a process of continuous development. Thus, they are subject to change.

1.1 Further information

On our website (www.thomann.de) you will find lots of further information and details on the following points:

Download	This manual is also available as PDF file for you to download.
Keyword search	Use the search function in the electronic version to find the topics of interest for you quickly.
Online guides	Our online guides provide detailed information on technical basics and terms.
Personal consultation	For personal consultation please contact our technical hotline.
Service	If you have any problems with the device the customer service will gladly assist you.

1.2 Notational conventions

This manual uses the following notational conventions:

Letterings

The letterings for connectors and controls are marked by square brackets and italics.

Examples: *[VOLUME]* control, *[Mono]* button.



Displays

Texts and values displayed on the device are marked by quotation marks and italics.

Examples: *'24ch'*, *'OFF'*.

1.3 Symbols and signal words

In this section you will find an overview of the meaning of symbols and signal words that are used in this manual.

Signal word	Meaning
DANGER!	This combination of symbol and signal word indicates an immediate dangerous situation that will result in death or serious injury if it is not avoided.
WARNING!	This combination of symbol and signal word indicates a possible dangerous situation that can result in death or serious injury if it is not avoided.
NOTICE!	This combination of symbol and signal word indicates a possible dangerous situation that can result in material and environmental damage if it is not avoided.
Warning signs	Type of danger
	Warning – high-voltage.
	Warning – suspended load.

Warning signs	Type of danger
	Warning – danger zone.

2 Safety instructions

Intended use

This device is intended to be used as an electronic illumination effect using LED technics. The device is designed for professional use and is not suitable for use in households. Use the device only as described in this user manual. Any other use or use under other operating conditions is considered to be improper and may result in personal injury or property damage. No liability will be assumed for damages resulting from improper use.

This device may be used only by persons with sufficient physical, sensorial, and intellectual abilities and having corresponding knowledge and experience. Other persons may use this device only if they are supervised or instructed by a person who is responsible for their safety.

Safety**DANGER!****Danger for children**

Ensure that plastic bags, packaging, etc. are disposed of properly and are not within reach of babies and young children. Choking hazard!

Ensure that children do not detach any small parts (e.g. knobs or the like) from the unit. They could swallow the pieces and choke!

Never let children unattended use electrical devices.

**DANGER!****Electric shock caused by high voltages inside**

Within the device there are areas where high voltages may be present. Never remove any covers.

There are no user-serviceable parts inside.

Do not use the device if covers, protectors or optical components are missing or damaged.



DANGER!

Electric shock caused by short-circuit

Do not modify the mains cable or the plug. Failure to do so could result in electric shock/death or fire. If in doubt, seek advice from a registered electrician.



WARNING!

Eye damage caused by high light intensity

Never look directly into the light source.



WARNING!

Risk of epileptic shock

Strobe lighting can trigger seizures in photosensitive epilepsy. Sensitive persons should avoid looking at strobe lights.



NOTICE!

Risk of fire

Do not cover the device nor any ventilation slots. Do not place the device near any direct heat source. Keep the device away from naked flames.



NOTICE!

Operating conditions

This device has been designed for indoor use only. To prevent damage, never expose the device to any liquid or moisture. Avoid direct sunlight, heavy dirt, and strong vibrations.



NOTICE!

Power supply

Before connecting the device, ensure that the input voltage (AC outlet) matches the voltage rating of the device and that the AC outlet is protected by a residual current circuit breaker. Failure to do so could result in damage to the device and possibly injure the user.

Unplug the device before electrical storms occur and when it is unused for long periods of time to reduce the risk of electric shock or fire.

3 Features

The CX series brings all-new colour creations in the line of LED lights. The multi-chip LEDs provide an unprecedented colour mixing in all spectra. Pastel colours, vivid and vibrant colours and white shades can be displayed extremely accurately with the headlights of the CX series.

Special features of the device:

- 10 × RGBA high power LEDs (8 W)
- 5 × RGBW high power LEDs (8 W)
- 42 preprogrammed automatic shows
- Control via DMX (3, 5, 7 or 8 channels) and via buttons and display on the unit
- Auto mode and sound control
- Master / Slave operation
- Aluminum die-cast housing, black

4 Installation

Unpack and carefully check that there is no transportation damage before using the unit. Keep the equipment packaging. To fully protect the device against vibration, dust and moisture during transportation or storage use the original packaging or your own packaging material suitable for transport or storage, respectively.



WARNING!

Risk of injury caused by falling objects

Make sure that the installation complies with the standards and rules that apply in your country. Always secure the device with a secondary safety attachment, such as a safety cable or a safety chain.



NOTICE!

Risk of overheating

Always ensure sufficient ventilation.

The ambient temperature must always be below 40 °C (104 °F).



NOTICE!

Use of stands

When mounting the device onto a stand, ensure that the stand is in a safe and stable position and that the weight of the device does not exceed the maximum permissible load capacity of the stand.



NOTICE!

Possible data transmission errors

For error-free operation make use of dedicated DMX cables and do not use ordinary microphone cables.

Never connect the DMX input or output to audio devices such as mixers or amplifiers.

Mounting options

You can install the device standing or hanging upside down. When in use, the device must be mounted at a solid surface or clamped to an approved truss. Use the openings of the two-piece bracket provided for mounting.

Work from a stable platform whenever you install or move the device or when you perform any kind of maintenance. Block access under the work area.

The safety cable must be attached to the bracket.



Please note that this device must not be connected to a dimmer.

5 Starting up

Establish all connections as long as the unit is switched off. Use the shortest possible high-quality cables for all connections.

Connections in DMX mode

Connect the DMX input of the device to the DMX output of a DMX controller or another DMX device. Connect the output of the first DMX device to the input of the second one, and so on to form a daisy chain. Always ensure that the output of the last DMX device in the daisy chain is terminated with a resistor ($110\ \Omega$, $\frac{1}{4}\ \text{W}$).

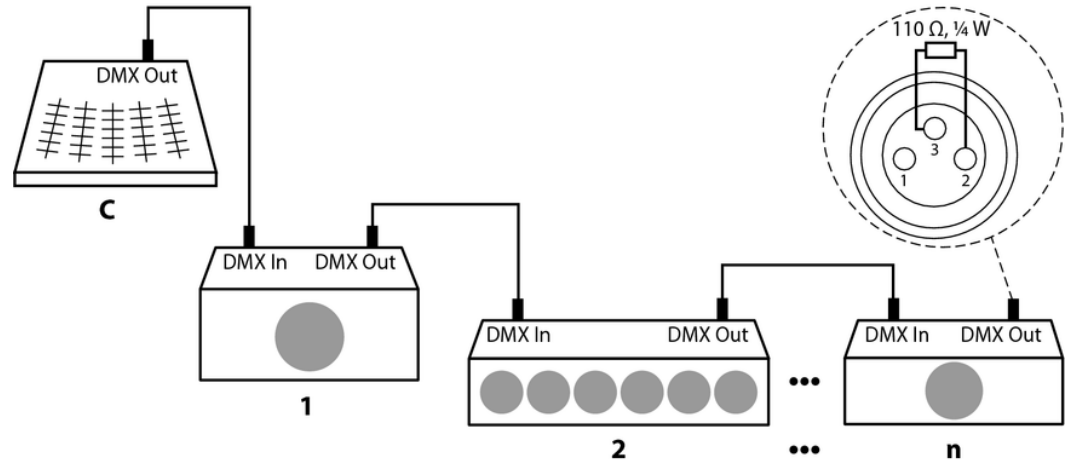

Connections in master/slave mode

When you configure a group of devices in master/slave mode, the first unit will control the other units for an automatic, sound-activated, synchronized show. This function is ideal when you want to start a show immediately. Connect the DMX output of the master device to the DMX input of the first slave device. Then connect the DMX output of the first slave device to the DMX input of the second slave device and so on.

6 Connections and controls

Rear panel

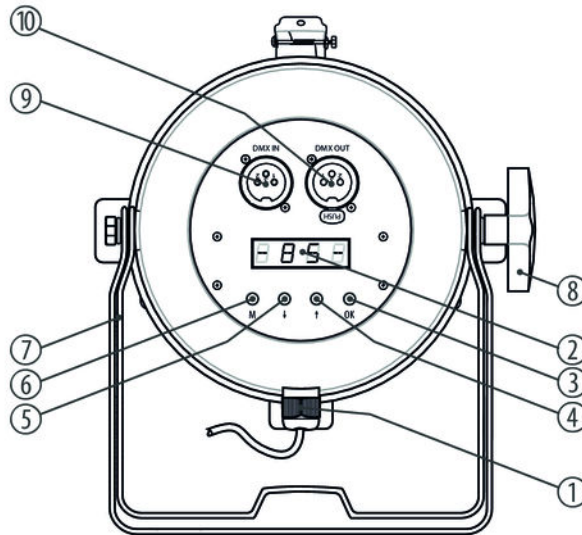

STAGE-PAR CX-2 RGBAW

1	Power cord.
2	Display.
3	[OK] button Confirms a selected value.
4,5	↑ button ↓ Increases / decreases the displayed value by one.
6	[M] button Calls the main menu or a submenu.
7	Bracket for floor placement or hanging.
8	Locking screws for the mounting bracket.

9	<i>[DMX IN]</i> DMX input.
10	<i>[DMX OUT]</i> DMX output.

7 Operating

7.1 Starting up the device

Connect the unit to the power grid to start the operation. After a few seconds the display shows the value 'DMX'. Then the unit is operational.

7.2 Main menu

Immediately after turning on, the device displays the main menu. Use the arrow keys to select the desired operating mode. Use the arrow keys to change the respectively displayed value. When the display shows the desired value, press OK.

DMX mode

Press *[M]*. Press one of the arrow keys repeatedly until the display shows 'SET'. Press *[OK]*. Press one of the arrow keys repeatedly until the display shows 'MODE'. Press *[OK]*. Now use the arrow keys to select one of the following DMX operating modes:

- '3CH' (three channels)
- '5CH' (five channels)
- '7CH' (seven channels)
- '8CH' (eight channels)

This setting is only relevant if the unit is controlled via DMX. When the display shows the desired value, press *[OK]* to confirm the selection, and then *[M]* to return to the parent menu. To return to the parent menu without any changes, press *[M]*.

DMX address

Press *[M]*. Press one of the arrow keys repeatedly until the display shows 'DMX'. Press *[OK]*. Now you can set the number of the first DMX channel to be used by the device (DMX address). Select a value between 1 and 512 with the arrow keys (display shows 'A001' ... 'A512').

When the display shows the desired value, press *[OK]* to confirm the selection, and then *[M]* to return to the parent menu. To return to the parent menu without any changes, press *[M]*.

Make sure that this number matches the configuration of your DMX controller. The following table shows the highest possible DMX address for the various DMX modes.

Mode	Highest possible DMX address
3-channel	510
5-channel	508
7-channel	506
8-channel	505

Operating mode 'Show/Master'

Press [M]. Press one of the arrow keys repeatedly until the display shows 'LINE'. Press [OK]. Press one of the arrow keys repeatedly until the display shows 'MA'. Press [OK]. Now you can select one of the 42 preprogrammed automatic shows. Use the arrow keys to select a value between 1 and 42 (display shows 'P-01' ... 'P-42').

The automatic show can only be activated on the unit, that operates as Master.

This setting is only relevant if the unit is not controlled via DMX. The device can work in stand-alone mode or control connected devices of the same type, which must be configured as slave. When the display shows the desired value, press [OK] to confirm the selection, and then [M] to return to the parent menu. To return to the parent menu without any changes, press [M].



In a Master / Slave configuration all devices need to be set to 8-channel mode (activate via DMX mode, 'SET', 'MODE', '8CH').

Operating mode 'Slave'

Press *[M]*. Press one of the arrow keys repeatedly until the display shows 'LINE'. Press *[OK]*. Press one of the arrow keys repeatedly until the display shows 'SL'. Press *[OK]*. Now you can set the number of the device through which it is addressed as Slave by the Master. Select a value between 1 and 512 with the arrow keys (display shows 'A001' ... 'A512').

This setting is only relevant if the unit works as slave controlled by a master, but not via DMX. When the display shows the desired value, press *[OK]* to confirm the selection, and then *[M]* to return to the parent menu. To return to the parent menu without any changes, press *[M]*.



In a Master / Slave configuration all devices need to be set to 8-channel mode (activate via DMX mode, 'SET', 'MODE', '8CH').

Programme speed

Press *[M]*. Press one of the arrow keys repeatedly until the display shows 'SET'. Press *[OK]*. Press one of the arrow keys repeatedly until the display shows 'SPEE'. Press *[OK]*. Now you can set the programme speed for the preprogrammed automatic shows. Select a value between 1 and 255 with the arrow keys (display shows 'T001' ... 'T255').

This setting is only relevant if the unit is not controlled via DMX. When the display shows the desired value, press *[OK]* to confirm the selection, and then *[M]* to return to the parent menu. To return to the parent menu without any changes, press *[M]*.

Microphone sensitivity

Press *[M]*. Press one of the arrow keys repeatedly until the display shows 'SET'. Press *[OK]*. Press one of the arrow keys repeatedly until the display shows 'MIC'. Press *[OK]*. Now you can adjust the sensitivity of the built-in microphone for the sound control. Use the arrow keys to select either 'OFF' (microphone off) or a value between 1 and 30 (display shows 'M-01' ... 'M-30').

This setting is only relevant if the unit is not controlled via DMX. When the display shows the desired value, press *[OK]* to confirm the selection, and then *[M]* to return to the parent menu. To return to the parent menu without any changes, press *[M]*.

Manual test

Press *[M]*. Press one of the arrow keys repeatedly until the display shows 'TEST'. Press *[OK]*. Press one of the arrow keys repeatedly until the display shows 'RED', 'GREE', 'BLUE', 'AMBE', 'WHIT' or 'STRO'. Press *[OK]*. Now you can adjust the brightness of the red, green, blue, amber-coloured or white LEDs, each in a range of 0 to 255, or select the blinking speed in a range of 0 to 24.

This operation mode is also suitable to produce constant or flashing light of a colour mixed from the five LED colours without DMX control.

When the display shows the desired value, press *[OK]* to confirm the selection, and then *[M]* to return to the parent menu. To return to the parent menu without any changes, press *[M]*.

Fade speed

Press *[M]*. Press one of the arrow keys repeatedly until the display shows 'FADE'. Press *[OK]*. Now you can adjust the fade speed of the preprogrammed automatic shows. Select a value between 1 and 7 with the arrow keys (display shows 'F-01' ... 'F-07').

This setting is only relevant if the unit is not controlled via DMX. When the display shows the desired value, press *[OK]* to confirm the selection and to return to the main menu. To return to the main menu without any changes, press *[M]*.

Colour selection

Press *[M]*. Press one of the arrow keys repeatedly until the display shows 'COLO'. Press *[OK]*. Now you can set the a basic colour for the preprogrammed automatic shows. Select a value between 1 and 4 with the arrow keys (display shows 'C-01' ... 'C-04').

This setting is only relevant if the unit is not controlled via DMX. When the display shows the desired value, press *[OK]* to confirm the selection and to return to the main menu. To return to the main menu without any changes, press *[M]*.

7.3 Menu overview

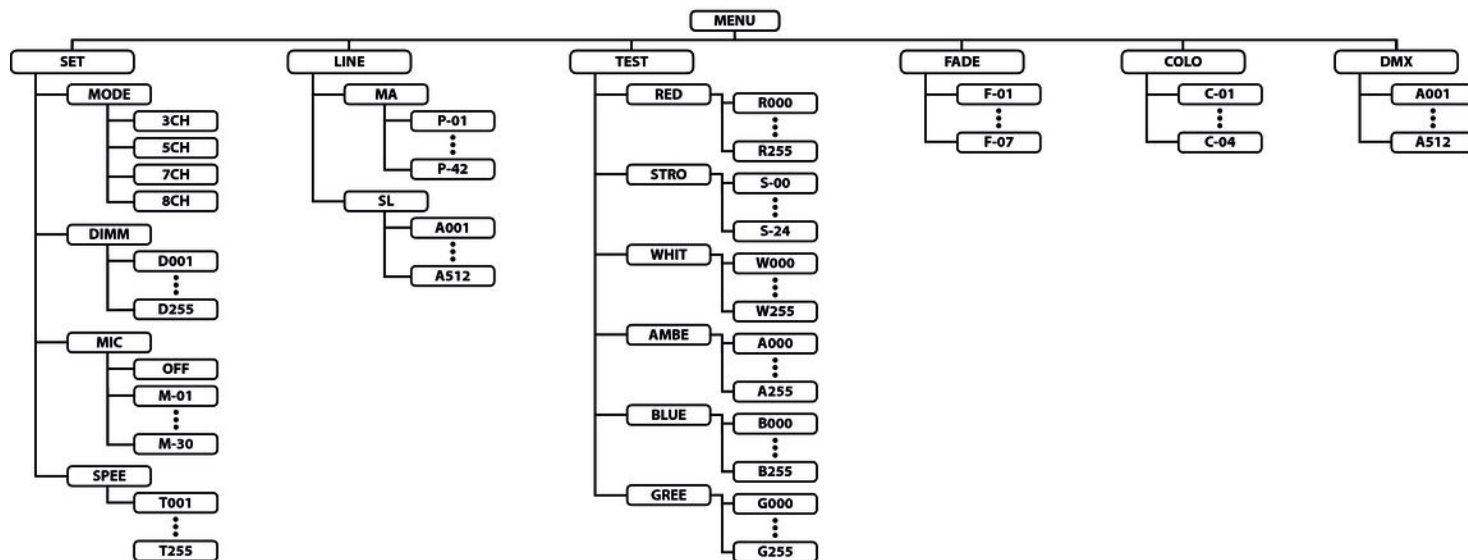

7.4 Functions im 3-channel DMX mode

Channel	Value	Function
1	008...255	42 preprogrammed colour macros (colour mixings)
2	0...255	Dimmer (0 % to 100 %)
3	0	Colouring
	1...10	Sound control
	11...255	Strobe effect

7.5 Functions im 5-channel DMX mode

Channel	Value	Function
1	0...255	Intensity red (0 % to 100 %)
2	0...255	Intensity green (0 % to 100 %)

Channel	Value	Function
3	0...255	Intensity blue (0 % to 100 %)
4	0...255	Intensity amber colour (0 % to 100 %), outer LED circle
5	0...255	Intensity white (0 % to 100 %), inner LED circle

7.6 Functions im 7-channel DMX mode

Channel	Value	Function
1	0...255	Intensity red (0 % to 100 %)
2	0...255	Intensity green (0 % to 100 %)
3	0...255	Intensity blue (0 % to 100 %)
4	0...255	Intensity amber colour (0 % to 100 %), outer LED circle
5	0...255	Intensity white (0 % to 100 %), inner LED circle

Channel	Value	Function
6	0...255	Dimmer (0 % to 100 %)
7	0	Colouring
	1...10	Sound control
	11...255	Strobe effect

7.7 Functions im 8-channel DMX mode

Channel	Value	Function
1	0...255	Intensity red (0 % to 100 %), outer LED circle
2	0...255	Intensity green (0 % to 100 %), outer LED circle
3	0...255	Intensity blue (0 % to 100 %), outer LED circle
4	0...255	Intensity amber colour (0 % to 100 %), outer LED circle

Channel	Value	Function
5	0...255	Intensity red (0 % to 100 %), inner LED circle
6	0...255	Intensity green (0 % to 100 %), inner LED circle
7	0...255	Intensity blue (0 % to 100 %), inner LED circle
8	0...255	Intensity white (0 % to 100 %), inner LED circle

8 Technical data

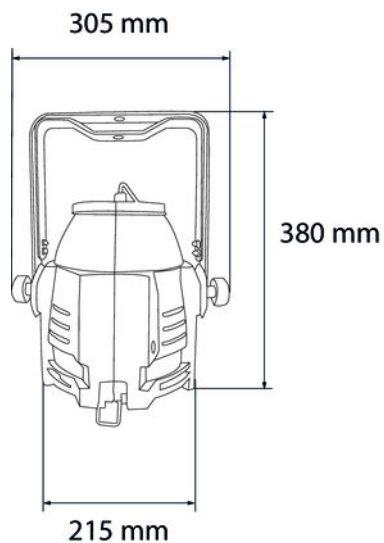

LEDs	10 × High-Power RGBA (8 W) 5 × High-Power RGBW (8 W)
Beam angle	25°
Number of DMX channels	3, 5, 7, 8
Mains power supply	230 V ~ 50 Hz
Power consumption	107 W
Dimensions	305 mm x 380 mm x 215 mm
Weight	4,4 kg

9 Plug and connection assignments

Introduction

This chapter will help you select the right cables and plugs to connect your valuable equipment so that a perfect light experience is guaranteed.

Please take our tips, because especially in 'Sound & Light' caution is indicated: Even if a plug fits into a socket, the result of an incorrect connection may be a destroyed DMX controller, a short circuit or 'just' a not working light show!

DMX connections

The unit offers a 3-pin XLR socket for DMX output and a 3-pin XLR plug for DMX input. Please refer to the drawing and table below for the pin assignment of a suitable XLR plug.



Pin	Configuration
1	Ground, shielding
2	Signal inverted (DMX-, 'cold signal')
3	Signal (DMX+, 'hot signal')

10 Troubleshooting



NOTICE!

Possible data transmission errors

For error-free operation make use of dedicated DMX cables and do not use ordinary microphone cables.

Never connect the DMX input or output to audio devices such as mixers or amplifiers.

In the following we list a few common problems that may occur during operation. We give you some suggestions for easy troubleshooting:

Symptom	Remedy
The unit does not work, no light.	Check the mains connection and the fuse.
No response to the DMX controller.	1. Check the DMX ports and cables for proper connection.
	2. Check the address settings and the DMX polarity.
	3. Try using another DMX controller.
	4. Check to see if the DMX cables run near or alongside to high voltage cables that may cause damage or interference to DMX interface circuits.

If the procedures recommended above do not succeed, please contact our Service Center. You can find the contact information at www.thomann.de.

11 Cleaning

Optical lenses

Clean the optical lenses, that are accessible from the outside, regularly in order to optimize the light output. The frequency of cleaning depends on the operating environment: wet, smoky or particularly dirty surroundings can cause more accumulation of dirt on the optics of the device.

- Clean with a soft cloth using our lamp and lens cleaner (item no. 280122).
- Always dry the parts carefully.

Fan grids

The fan grids of the device must be cleaned on a regular basis to remove dust and dirt. Before cleaning, switch off the device and disconnect AC-powered devices from the mains. Use a lint-free damp cloth for cleaning. Never use solvents or alcohol for cleaning.

12 Protecting the environment

Disposal of the packaging material



For the transport and protective packaging, environmentally friendly materials have been chosen that can be supplied to normal recycling.

Ensure that plastic bags, packaging, etc. are properly disposed of.

Do not just dispose of these materials with your normal household waste, but make sure that they are collected for recycling. Please follow the notes and markings on the packaging.

Disposal of your old device



This product is subject to the European Waste Electrical and Electronic Equipment Directive (WEEE). Do not dispose with your normal household waste.

Dispose of this device through an approved waste disposal firm or through your local waste facility. When discarding the device, comply with the rules and regulations that apply in your country. If in doubt, consult your local waste disposal facility.

STAGE-PAR CX-2 RGBAW



