



STAIRVILLE

Quad Par Profile
5x8W RGBW
5x8W RGB WW

LED PAR

Musikhaus Thomann
Thomann GmbH
Hans-Thomann-Straße 1
96138 Burgebrach
Germany
Telephone: +49 (0) 9546 9223-0
E-mail: info@thomann.de
Internet: www.thomann.de

19.11.2018, ID: 307515, 405343, 414496, 414497 (V4)

Table of contents

1	General notes	5
	1.1 Further information.....	6
	1.2 Notational conventions.....	7
	1.3 Symbols and signal words.....	7
2	Safety instructions	10
3	Features	15
4	Installation	16
5	Starting up	20
6	Connections and controls	23
7	Operation	34
	7.1 Starting the device.....	34
	7.2 Operating controls on the device.....	34
	7.3 Menu overview.....	40
	7.4 Remote control.....	41
	7.5 Functions in 4-channel DMX mode.....	44

7.6	Functions in 6-channel DMX mode.....	44
7.7	Functions in 8-channel DMX mode (Stairville Quad Par Profile 5x8W RGBW, Art. No. 307515).....	45
7.8	Functions in 8-channel DMX mode (Stairville Quad Par Profile 5x8W RGBW, Art. No. 405343).....	49
8	Technical specifications.....	53
9	Plug and connection assignments.....	55
10	Troubleshooting.....	56
11	Cleaning.....	59
12	Protecting the environment.....	60

1 General notes

This manual contains important instructions for the safe operation of the unit. Read and follow the safety instructions and all other instructions. Keep the manual for future reference. Make sure that it is available to all those using the device. If you sell the unit please make sure that the buyer also receives this manual.

Our products are subject to a process of continuous development. Thus, they are subject to change.

1.1 Further information

On our website (www.thomann.de) you will find lots of further information and details on the following points:

Download	This manual is also available as PDF file for you to download.
Keyword search	Use the search function in the electronic version to find the topics of interest for you quickly.
Online guides	Our online guides provide detailed information on technical basics and terms.
Personal consultation	For personal consultation please contact our technical hotline.
Service	If you have any problems with the device the customer service will gladly assist you.

1.2 Notational conventions

This manual uses the following notational conventions:

Letterings

The letterings for connectors and controls are marked by square brackets and italics.

Examples: *[VOLUME]* control, *[Mono]* button.



Displays

Texts and values displayed on the device are marked by quotation marks and italics.

Examples: *'24ch'*, *'OFF'*.

1.3 Symbols and signal words

In this section you will find an overview of the meaning of symbols and signal words that are used in this manual.

Signal word	Meaning
DANGER!	This combination of symbol and signal word indicates an immediate dangerous situation that will result in death or serious injury if it is not avoided.
WARNING!	This combination of symbol and signal word indicates a possible dangerous situation that can result in death or serious injury if it is not avoided.
NOTICE!	This combination of symbol and signal word indicates a possible dangerous situation that can result in material and environmental damage if it is not avoided.
Warning signs	Type of danger
	Warning – high-voltage.
	Warning – suspended load.

Warning signs	Type of danger
	Warning – danger zone.

2 Safety instructions

Intended use

This device is intended to be used as an electronic illumination effect using LED technics. The device is designed for professional use and is not suitable for use in households. Use the device only as described in this user manual. Any other use or use under other operating conditions is considered to be improper and may result in personal injury or property damage. No liability will be assumed for damages resulting from improper use.

This device may be used only by persons with sufficient physical, sensorial, and intellectual abilities and having corresponding knowledge and experience. Other persons may use this device only if they are supervised or instructed by a person who is responsible for their safety.

Safety**DANGER!****Danger for children**

Ensure that plastic bags, packaging, etc. are disposed of properly and are not within reach of babies and young children. Choking hazard!

Ensure that children do not detach any small parts (e.g. knobs or the like) from the unit. They could swallow the pieces and choke!

Never let children unattended use electrical devices.

**DANGER!****Electric shock caused by high voltages inside**

Within the device there are areas where high voltages may be present. Never remove any covers.

There are no user-serviceable parts inside.

Do not use the device if covers, protectors or optical components are missing or damaged.



DANGER!

Electric shock caused by short-circuit

Always use proper ready-made insulated mains cabling (power cord) with a protective contact plug. Do not modify the mains cable or the plug. Failure to do so could result in electric shock/death or fire. If in doubt, seek advice from a registered electrician.



WARNING!

Eye damage caused by high light intensity

Never look directly into the light source.



WARNING!

Risk of epileptic shock

Strobe lighting can trigger seizures in photosensitive epilepsy. Sensitive persons should avoid looking at strobe lights.



NOTICE!

Risk of fire

Do not block areas of ventilation. Do not install the device near any direct heat source. Keep the device away from naked flames.



NOTICE!

Operating conditions

This device has been designed for indoor use only. To prevent damage, never expose the device to any liquid or moisture. Avoid direct sunlight, heavy dirt, and strong vibrations.



NOTICE!

Power supply

Before connecting the device, ensure that the input voltage (AC outlet) matches the voltage rating of the device and that the AC outlet is protected by a residual current circuit breaker. Failure to do so could result in damage to the device and possibly injure the user.

Unplug the device before electrical storms occur and when it is unused for long periods of time to reduce the risk of electric shock or fire.

3 Features

The LED PAR is particularly suitable for professional lighting tasks, for example at events, on rock stages, in theatres and musicals. It's characterized by low power consumption and long service life.

Special features of the device:

- Five four-colour LEDs, 8 W each
 - Stairville Quad Par Profile 5x8W RGBW, item no. 307515 and 414496: red, green, blue, white
 - Stairville Quad Par Profile 5x8W RGB WW, item no. 405343 and 414497: red, green, blue, warm white
- Control via DMX (three different modes), with the supplied infrared remote control or the buttons and display on the unit
- Eleven preprogrammed automatic shows
- Sound control
- Master/Slave mode
- Robust metal housing

4 Installation

Unpack and carefully check that there is no transportation damage before using the unit. Keep the equipment packaging. To fully protect the device against vibration, dust and moisture during transportation or storage use the original packaging or your own packaging material suitable for transport or storage, respectively.



WARNING!

Risk of injury caused by falling objects

Make sure that the installation complies with the standards and rules that apply in your country. Always secure the device with a secondary safety attachment, such as a safety cable or a safety chain.



NOTICE!

Risk of overheating

Always ensure sufficient ventilation.

The ambient temperature must always be below 40 °C (104 °F).



NOTICE!

Use of stands

When mounting the device onto a stand, ensure that the stand is in a safe and stable position and that the weight of the device does not exceed the maximum permissible load capacity of the stand.



NOTICE!

Possible data transmission errors

For error-free operation make use of dedicated DMX cables and do not use ordinary microphone cables.

Never connect the DMX input or output to audio devices such as mixers or amplifiers.

Options

You can install the device in either the hanging or standing position. During use, the device must always be attached to a solid surface or to an approved support. Use the openings provided on the two-piece bracket for attaching.

Always work from a stable platform whenever installing, moving or servicing the unit. In doing so, the area underneath the device must be cordoned off.

The safety-rope must be attached to the bracket.

Infra red receiver for the remote control signal

The infra red receiver for the remote control signals is located near the main LED on the front panel of the device. Make sure it's not covered.

Inserting the battery into the remote control

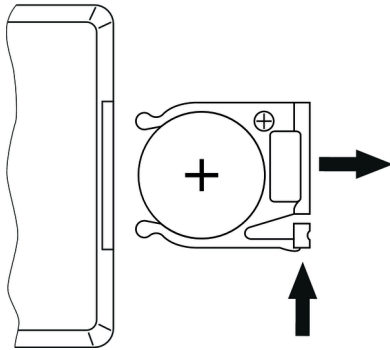

Press the lock of the battery holder to the centre of the housing and pull out the battery holder like a drawer. Insert the battery. The battery is correct if the positive pole points to the housing base of the remote control. Slide the battery holder back into the remote until it clicks into place.

When shipping, the battery is already installed in the remote and protected against discharge by a transparent plastic foil. Remove the plastic foil prior to first use.

5 Starting up

Create all connections while the device is off. Use the shortest possible high-quality cables for all connections. Take care when running the cables to prevent tripping hazards.

Connections in DMX mode

Connect the DMX input of the device to the DMX output of a DMX controller or another DMX device. Connect the output of the first DMX device to the input of the second one, and so on to form a daisy chain. Always ensure that the output of the last DMX device in the daisy chain is terminated with a resistor ($110\ \Omega$, $\frac{1}{4}\ \text{W}$).

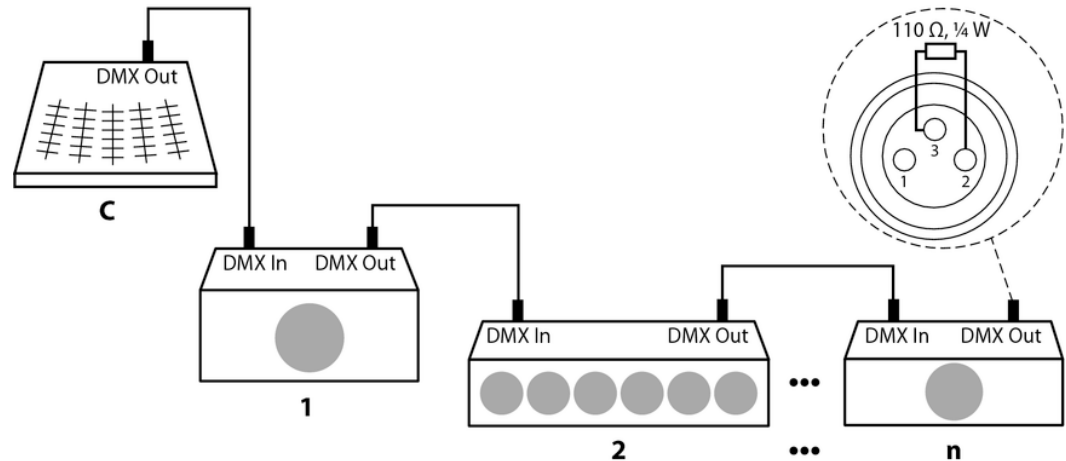

DMX indicator

If the unit is in DMX mode and a DMX controller is connected and turned on, the 'd' is flashing in the first digit of the display.

Connections in master/slave mode

When you configure a group of devices in master/slave mode, the first unit will control the other units for an automatic, sound-activated, synchronized show. This function is ideal when you want to start a show immediately. Connect the DMX output of the master device to the DMX input of the first slave device. Then connect the DMX output of the first slave device to the DMX input of the second slave device and so on.

6 Connections and controls

Overview

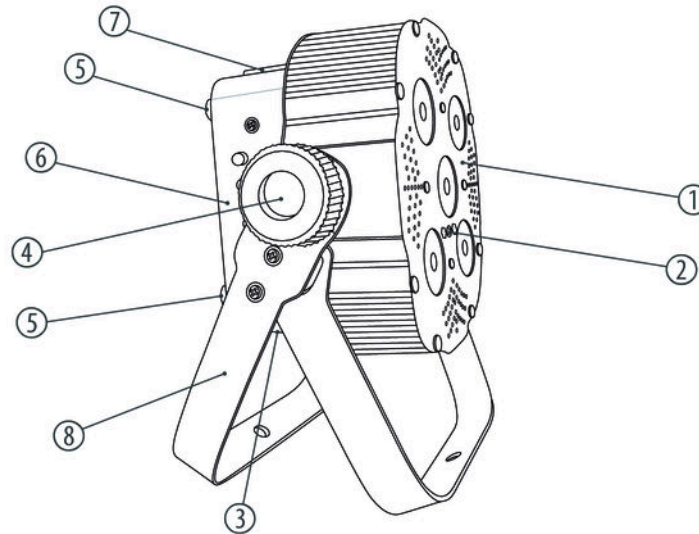

Quad Par Profile 5x8W RGBW 5x8W RGB WW

1	Front panel
2	Infrared receiver for the IR remote control signal.
3	Bottom side with inputs (DMX and power supply).
4	Locking screws for the mounting brackets.
5	Rubber feet for floor placement.
6	Lateral controls.
7	Top side and outputs (DMX and power supply to other devices).
8	Mounting brackets for floor placement or hanging.

Top side

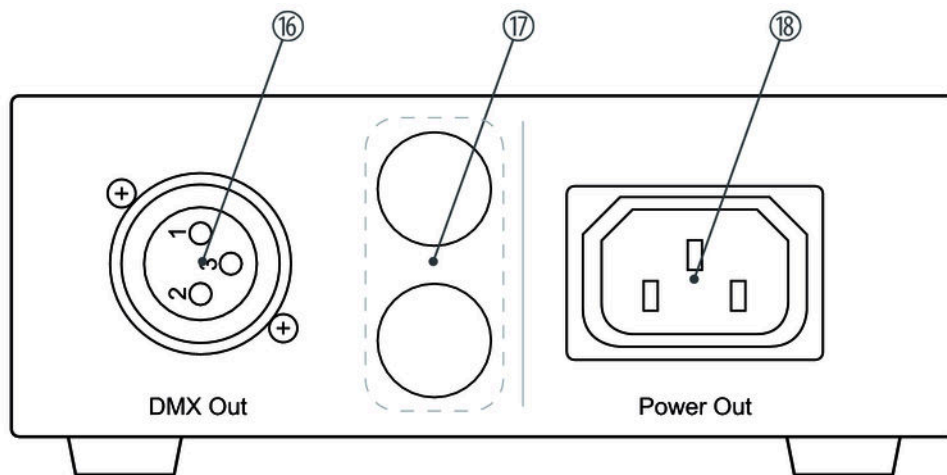

Quad Par Profile 5x8W RGBW 5x8W RGB WW

16	<i>[DMX Out]</i> DMX output.
17	Notches for safety rope.
18	<i>[POWER Out]</i> IEC chassis socket for the power supply cable to the next unit.

Bottom

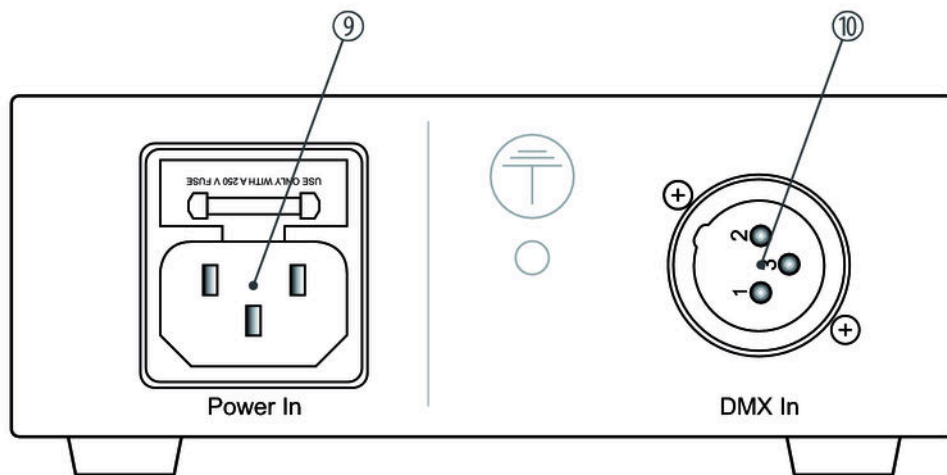

Quad Par Profile 5x8W RGBW 5x8W RGB WW

9	<i>[POWER In]</i> IEC chassis plug for operating voltage supply with fuse holder.
10	<i>[DMX In]</i> DMX input.

Lateral controls

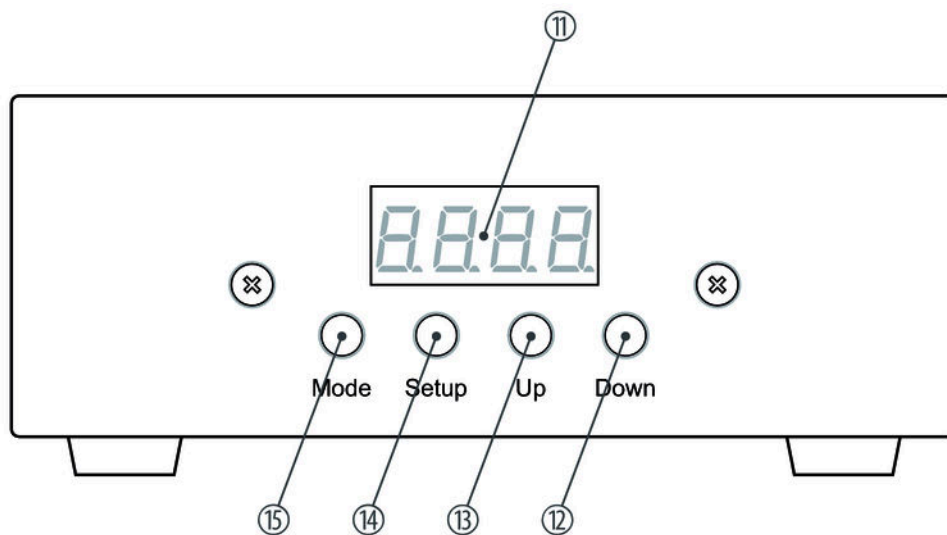

Quad Par Profile 5x8W RGBW 5x8W RGB WW

11	Display.
12	Button [<i>Down</i>] Navigates downwards in a menu list. Decrements the displayed value by one.
13	Button [<i>Up</i>] Navigates upwards in a menu list. Increments the displayed value by one.
14	Button [<i>Setup</i>] Chooses between the options of the selected mode.
15	Button [<i>Mode</i>] Activates the main menu and moves between menu items.

Remote control

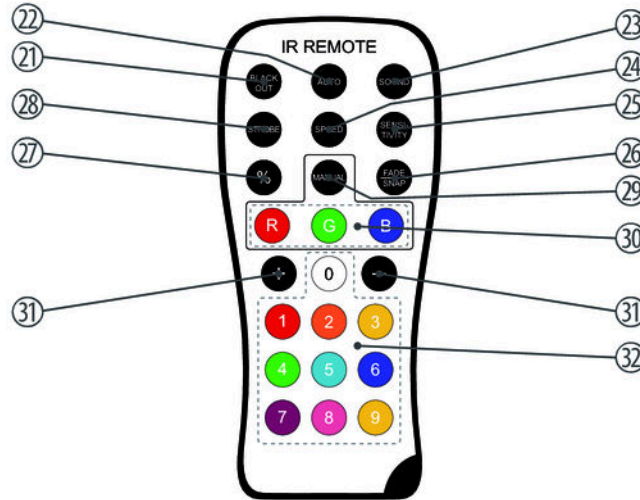

Quad Par Profile 5x8W RGBW 5x8W RGB WW

21	<i>[BLACK OUT]</i> Enables or disables blackout.
22	<i>[AUTO]</i> Enables or disables auto mode.
23	<i>[SOUND]</i> Starts the sound-controlled automatic show.
24	<i>[SPEED]</i> Allows setting the speed for the flash light function using the <i>[+]</i> and <i>[-]</i> buttons.
25	<i>[SENSITIVITY]</i> Allows setting the sensitivity for the sound control using the <i>[+]</i> and <i>[-]</i> buttons.
26	<i>[FADE / SNAP]</i> No function.
27	<i>[%]</i> Resets the displayed value to zero during value setting (flash light speed, sound control sensitivity).

28	<i>[STROBE]</i> Enables or disables the flash light function (strobe effect) with the last selected colour.
29	<i>[MANUAL]</i> Activates the display of a constant colour that you can either mix from the basic colours using the buttons <i>[R]</i> , <i>[G]</i> and <i>[B]</i> , or select directly with one of the colour buttons.
30	<i>[R], [G], [B]</i> Sets the intensity of the three basic colours red, green and blue when displaying a constant colour.
31	<i>[+], [-]</i> Increases or decreases the set value.
32	Direct selection button for mixed colours.

7 Operation

7.1 Starting the device

Connect the device to the power supply to start operation. After a few seconds, the display indicates that a reset is in progress. The device is then ready for use.

7.2 Operating controls on the device

Press *[Mode]* to activate the main menu and select an operating mode. Use *[Setup]* to select further options. Use *[Up]* and *[Down]* to change the respectively displayed value. When the display shows the desired value, press *[MODE]*.

If you do not press any buttons for about ten seconds, the display will be blanked. It will be reactivated to display the previously called menu by pressing any button.

The set values are retained even when the device is disconnected from the mains power supply.

Operating mode 'Preprogrammed automatic show'

A preprogrammed automatic show can only be activated when the unit is operating in stand-alone mode or as master in a master / slave combination. This setting takes effect only when the device is not operated under DMX control.

Press *[Mode]* repeatedly until the display shows 'Pr.xx'. Now you can select one of the preprogrammed automatic shows. Use *[Up]* and *[Down]* to select a value between 'Pr.01' and 'Pr.10'.

Settings for programme 01:

For 'Pr.01', you can choose from 13 predefined colours or blackout. Press *[Setup]*. With *[Up]* and *[Down]* you can now select one of the colours (display '1.__r' to '13.on') or blackout (display '0.OFF').

To adjust the strobe frequency, press *[Setup]* again. The display shows 'FS.xx'. Now use *[Up]* and *[Down]* to select a value between 'FS.00' (slow) and 'FS.99' (fast).

Settings for programmes 02 to 10:

To adjust the programme speed, press again *[Setup]*. The display shows 'SP.xx'. Using *[Up]* and *[Down]* you can now select a value between 'SP.01' (slow) and 'SP.FL' (fast).

To adjust the strobe frequency, press *[Setup]* again. The display shows 'FS.xx'. Now use *[Up]* and *[Down]* to select a value between 'FS.00' (slow) and 'FS.99' (fast).

Operating mode 'Automatic'

Automatic operation can only be activated when the unit is operating in stand alone mode or as master in a master / slave combination. This setting takes effect only when the device is not operated under DMX control.

Press *[Mode]* repeatedly until the display shows 'AUTO' . The playback of the built-in automatic programme starts automatically.

DMX mode

This setting is only relevant if the device is being controlled via DMX.

Press *[Mode]* until the display shows 'd.xxx'.

Now you can set the number of the first DMX channel used by the device (DMX address). Use *[Up]* and *[Down]* to select a value between 1 and 512 (display shows 'd.001' ... 'd.512').

Make sure this number matches the configuration of your DMX controller. The following table shows the highest possible DMX address for the different DMX modes.

Mode	Highest possible DMX address
4-channel	509
6-channel	507
8-channel	505

Press *[Setup]*. Using *[Up]* and *[Down]* you can now select one of the following DMX modes:

- '4-ch' (four channels)
- '6-ch' (six channels)
- '8-ch' (eight channels)

Operating mode 'Slave'

This setting is only relevant if the device is serving as Slave in a Master / Slave configuration and is not controlled via DMX.

Press *[Mode]* until the display shows 'SLAv'.

Sound control

The sound controlled automatic show can only be activated when the unit is operating in stand alone mode or as master in a master / slave combination. This setting takes effect only when the device is not operated under DMX control.

Press *[Mode]* until the display shows 'SUxx'. This activates the sound controlled automatic show.

Press *[Setup]* and use *[Up]* and *[Down]* to adjust the sensitivity for the sound control in a range from 'SV.00' to 'SV.31'.

Constant colour

A constant colour can only be activated when the unit is operating in stand-alone mode or as master in a master / slave combination. This setting takes effect only when the device is not operated under DMX control.

Press *[Mode]* until the display shows 'Colr'. Press *[Setup]*. The display shows the setting for one of the primary colours (display 'r.xxx', 'G.xxx' or 'b.xxx') or for white / warm white (display 'u.xxx'). Press *[Setup]* to change the colour.

Use *[Up]* and *[Down]* to adjust the intensity of the colour:

Display	Description
'r.000' ... 'r.255'	Red
'G.000' ... 'G.255'	Green
'b.000' ... 'b.255'	Blue
'u.000' ... 'u.255'	White / warm white

7.3 Menu overview

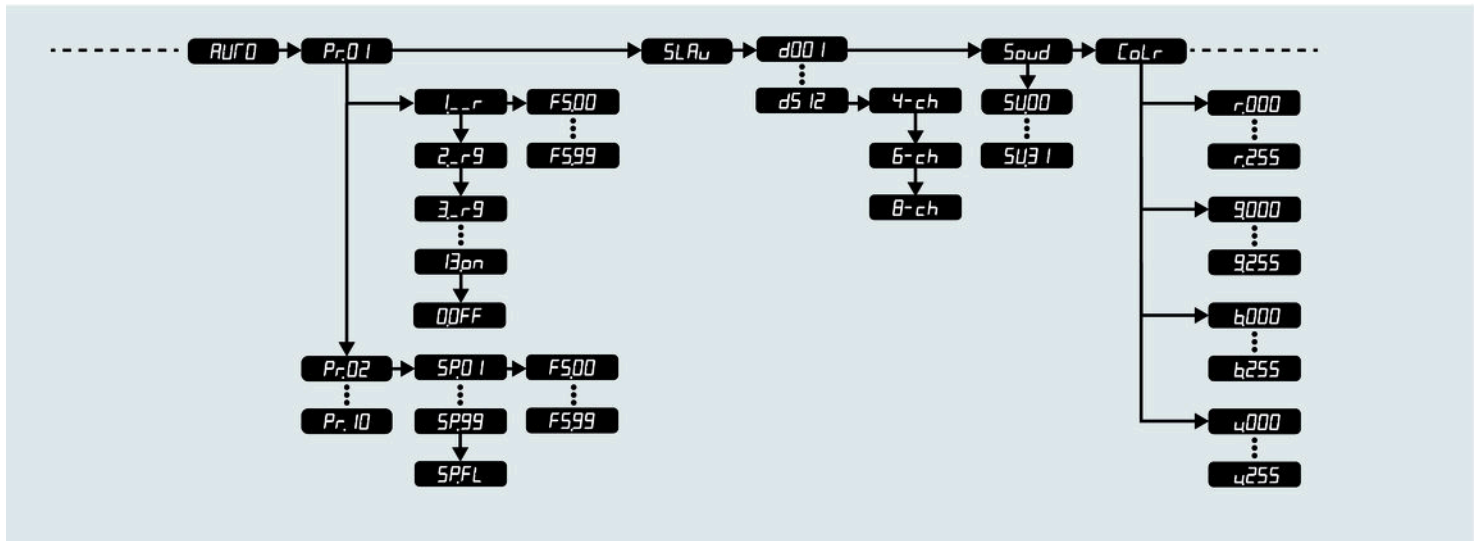

7.4 Remote control

Operating mode 'Preprogrammed automatic show'

A preprogrammed automatic show can only be activated when the unit is operating alone or as master in a master-slave combination. This setting is only relevant if the device is not controlled via DMX.

Press *[MANUAL]*. The display shows 'Pr.xx'. Now you can select one of the preprogrammed automatic shows. Use *[+]* and *[-]* to select a value between 'Pr.01' and 'Pr.10'.

Press *[SPEED]* to adjust the programme speed. The display shows 'SP.xx'. Use *[%]*, *[+]* and *[-]* to select a value between 'SP.01' (slow) and 'SP.FL' (fast).

Press *[STROBE]* to set the flash frequency. The display shows 'FS.xx'. Use *[%]*, *[+]* and *[-]* to select a value between 'FS.00' (slow) and 'FS.99' (fast).

Operating mode 'Automatic'

The automatic mode can only be activated when the unit is operating alone or as master in a master-slave combination. This setting is only relevant if the device is not controlled via DMX.

Press *[AUTO]*. The display shows 'AUTO', the playback of the built-in automatic programme starts automatically.

Sound control

The sound-controlled automatic show can only be activated when the unit is operating alone or as master in a master-slave combination. This setting is only relevant if the device is not controlled via DMX.

Press [*SOUND*]. The display shows '*SUxx*', the sound-controlled automatic show is activated.

Use [*%*], [*+*] and [*-*] to set the sensitivity for the sound control in a range between '*SV.00*' and '*SV.31*'.

Constant colour

A constant colour can only be activated when the unit is operating alone or as master in a master-slave combination. This setting is only relevant if the device is not controlled via DMX.

Press *[MANUAL]*. Now you can either call up a predefined colour directly with one of the coloured buttons, or mix a colour individually from the basic colours.

Press *[R]*, *[G]* or *[B]* to mix a colour individually from the basic colours. The display shows 'r.xxx', 'G.xxx' or 'b.xxx'.

Use *[%]*, *[+]* and *[-]* to set the colour intensity:

Display	Description
'r.000' ... 'r.255'	Red
'G.000' ... 'G.255'	Green
'b.000' ... 'b.255'	Blue

Blackout

Press *[BLACKOUT]* to switch the LEDs off or on again. Then the unit continues to operate in the last selected operating mode.

The Blackout function is only available when the unit is not controlled via DMX.

7.5 Functions in 4-channel DMX mode

Channel	Value	Function
1	0...255	Intensity Red (0 % to 100 %)
2	0...255	Intensity Green (0 % to 100 %)
3	0...255	Intensity Blue (0 % to 100 %)
4	0...255	Intensity white / warm white (0 % to 100 %)

7.6 Functions in 6-channel DMX mode

Channel	Value	Function
1	0...255	Intensity Red (0 % to 100 %)
2	0...255	Intensity Green (0 % to 100 %)
3	0...255	Intensity Blue (0 % to 100 %)

Channel	Value	Function
4	0...255	Intensity White / Warm White (0 % to 100 %)
5	0...255	Dimmer (0 % to 100 %)
6	0...255	Strobe effect, increasing speed

7.7 Functions in 8-channel DMX mode (Stairville Quad Par Profile 5x8W RGBW, Art. No. 307515)

Channel	Value	Function
1	0...255	Dimmer (0 % to 100 %)
2	0...255	Intensity Red (0 % to 100 %), if channel 6 = 0
3	0...255	Intensity Green (0 % to 100 %), if channel 6 = 0
4	0...255	Intensity Blue (0 % to 100 %), if channel 6 = 0

Channel	Value	Function
5	0...255	Intensity White (0 % to 100 %), if channel 6 = 0
6	Operating mode	
	0	Manual mode, all colours can be adjusted via channels 2 to 5
	1...24	Constant colour, depending on channel 7
	25...49	Preprogrammed automatic show no. 2
	50...74	Preprogrammed automatic show no. 3
	75...99	Preprogrammed automatic show no. 4
	100...124	Preprogrammed automatic show no. 5
	125...149	Preprogrammed automatic show no. 6
	150...174	Preprogrammed automatic show no. 7
	175...199	Preprogrammed automatic show no. 8
	200...224	Preprogrammed automatic show no. 9
	225...249	Preprogrammed automatic show no. 10

Channel	Value	Function
	250...255	Sound-controlled show
7	Constant colour, if channel 6 = 1...24:	
	0...18	Dark
	19...37	Red
	38...56	Orange
	57...75	Yellow
	76...93	Light green
	94...113	Light blue
	114...132	Blue
	133...151	Purple
	152...170	Pink
	171...189	White
	190...208	Red

Channel	Value	Function
	209...227	Green
	228...246	Blue
	247...255	Red + Green + Blue + White
	Process speed, if channel 6 = 25...255:	
	0...255	Increasing speed
8	0...255	Strobe effect, increasing speed

7.8 Functions in 8-channel DMX mode (Stairville Quad Par Profile 5x8W RGBW, Art. No. 405343)

Channel	Value	Function
1	0...255	Dimmer (0 % to 100 %)
2	0...255	Intensity Red (0 % to 100 %), if channel 6 = 0
3	0...255	Intensity Green (0 % to 100 %), if channel 6 = 0
4	0...255	Intensity Blue (0 % to 100 %), if channel 6 = 0
5	0...255	Intensity Warm White (0 % to 100 %), if channel 6 = 0
6	Operating mode	
	0	Manual mode, all colours can be adjusted via channels 2 to 5
	1...24	Constant colour, depending on channel 7
	25...49	Preprogrammed automatic show no. 2
	50...74	Preprogrammed automatic show no. 3

Channel	Value	Function
	75...99	Preprogrammed automatic show no. 4
	100...124	Preprogrammed automatic show no. 5
	125...149	Preprogrammed automatic show no. 6
	150...174	Preprogrammed automatic show no. 7
	175...199	Preprogrammed automatic show no. 8
	200...224	Preprogrammed automatic show no. 9
	225...249	Preprogrammed automatic show no. 10
	250...255	Sound-controlled show
7	Constant colour, if channel 6 = 1...24:	
	0...17	Dark
	18...35	Red + green + blue
	36...53	Red
	54...71	Red + green

Channel	Value	Function
	72...89	Red + green
	90...107	Green
	108...125	Green + blue
	126...143	Blue
	144...161	Red + blue
	162...179	Red + blue
	180...197	Warm white
	198...215	Red + warm white
	216...233	Green + warm white
	234...251	Blue + white
	252...255	Red + green + blue + warm white
	Process speed, if channel 6 = 25...255:	

Channel	Value	Function
	0...255	Increasing speed
8	0...255	Strobe effect, increasing speed

8 Technical specifications

Stairville Quad Par Profile 5x8W RGBW

	Item no. 307515	Item no. 414496
Dispersion angle	25°	45°
LEDs	5 four-colour LEDs (red, green, blue, white), 8 W each	
Number of DMX channels	4, 6, 8	
Battery (remote control)	Lithium button cell, CR 2025, 3 V	
Operating supply voltage	100 – 240 V~ 50/60 Hz	
Fuse	5 mm × 20 mm, 1 A, 250 V, slow blow	
Power consumption	32 W	
Dimensions (W × H × D)	164 mm × 164 mm × 105 mm	
Weight	2.1 kg	

Quad Par Profile 5x8W RGBW 5x8W RGB WW

**Stairville Quad Par Profile 5x8W
RGB WW**

	Item no. 405343	Item no. 414497
Dispersion angle	25°	45°
LEDs	5 four-colour LEDs (red, green, blue, warm white), 8 W each	
Number of DMX channels	4, 6, 8	
Battery (remote control)	Lithium button cell, CR 2025, 3 V	
Operating supply voltage	100 – 240 V~ 50/60 Hz	
Fuse	5 mm × 20 mm, 1 A, 250 V, slow blow	
Power consumption	33 W	
Dimensions (W × H × D)	164 mm × 164 mm × 105 mm	
Weight	2.1 kg	

9 Plug and connection assignments

Introduction

This chapter will help you select the right cables and plugs to connect your valuable equipment so that a perfect light experience is guaranteed.

Please take our tips, because especially in 'Sound & Light' caution is indicated: Even if a plug fits into a socket, the result of an incorrect connection may be a destroyed DMX controller, a short circuit or 'just' a not working light show!

DMX connections



The unit offers a 3-pin XLR socket for DMX output and a 3-pin XLR plug for DMX input. Please refer to the drawing and table below for the pin assignment of a suitable XLR plug.

Pin	Configuration
1	Ground, shielding
2	Signal inverted (DMX-, 'cold signal')
3	Signal (DMX+, 'hot signal')

10 Troubleshooting



NOTICE!

Possible data transmission errors

For error-free operation make use of dedicated DMX cables and do not use ordinary microphone cables.

Never connect the DMX input or output to audio devices such as mixers or amplifiers.

In the following we list a few common problems that may occur during operation. We give you some suggestions for easy troubleshooting:

Symptom	Remedy
The unit does not work, no light.	Check the mains connection and the main fuse.
No response to the DMX controller.	<ol style="list-style-type: none"> 1. If the unit is in DMX mode and a DMX controller is connected and turned on, the 'd' flashes in the first position of the display. If not, no valid DMX signal is received. Check that the DMX controller is switched on. Check the DMX connectors and cables for proper connection. 2. If the display is not flashing and there is still no response, check the address settings and DMX polarity. 3. Try using another DMX controller. 4. Check to see if the DMX cables run near or alongside to high voltage cables that may cause damage or interference to DMX interface circuits.
No response to the remote control	<ol style="list-style-type: none"> 1. Try the remote control at a different angle to the receiver on the front of the device. 2. Move the remote control closer to the unit. 3. Check the remote control battery.

If the procedures recommended above do not succeed, please contact our Service Center. You can find the contact information at www.thomann.de.

11 Cleaning

Optical lenses

Clean the optical lenses, that are accessible from the outside, regularly in order to optimize the light output. The frequency of cleaning depends on the operating environment: wet, smoky or particularly dirty surroundings can cause more accumulation of dirt on the optics of the device.

- Clean with a soft cloth using our lamp and lens cleaner (item no. 280122).
- Always dry the parts carefully.

Fan grids

The fan grids of the device must be cleaned on a regular basis to remove dust and dirt. Before cleaning, switch off the device and disconnect AC-powered devices from the mains. Use a lint-free damp cloth for cleaning. Never use solvents or alcohol for cleaning.

12 Protecting the environment

Disposal of the packaging material



For the transport and protective packaging, environmentally friendly materials have been chosen that can be supplied to normal recycling.

Ensure that plastic bags, packaging, etc. are properly disposed of.

Do not just dispose these materials with your normal household waste, but make sure that they are fed to a recovery. Please follow the notes and markings on the packaging.

Disposal of batteries



Batteries must not be disposed of as domestic waste or thrown into fire. Dispose of the batteries according to national or local regulations regarding hazardous waste. To protect the environment, dispose of empty batteries at your retail store or at appropriate collection sites.

Disposal of your old device



This product is subject to the European Waste Electrical and Electronic Equipment Directive (WEEE) in its currently valid version. Do not dispose with your normal household waste.

Dispose this device through an approved waste disposal firm or through your local waste facility. When discarding the device, comply with the rules and regulations that apply in your country. If in doubt, consult your local waste disposal facility.



