



GigA Pro Vocal Set UHF wireless system



Musikhaus Thomann
Thomann GmbH
Hans-Thomann-Straße 1
96138 Burgebrach
Germany
Telephone: +49 (0) 9546 9223-0
E-mail: info@thomann.de
Internet: www.thomann.de

01.02.2017, ID: 313901

Table of contents

1	General information	5
	1.1 Further information.....	6
	1.2 Notational conventions.....	7
	1.3 Symbols and signal words.....	8
2	Safety instructions	10
3	Features	15
4	Installation and starting up	17
	4.1 General Information.....	17
	4.2 Dealing with lithium batteries.....	19
	4.3 Receiver.....	20
5	Connections and controls	22
	5.1 Receiver.....	22
	5.2 Handheld microphone.....	28
	5.3 Rechargeable battery station.....	30

6	Operating.....	32
6.1	Receiver.....	32
6.2	Handheld microphone.....	38
7	Technical specifications.....	40
7.1	Receiver.....	40
7.2	Handheld microphone.....	41
7.3	Rechargeable battery station.....	42
8	Plug and connection assignment.....	43
9	Troubleshooting.....	45
10	Protecting the environment.....	48

1 General information

This manual contains important instructions for the safe operation of the unit. Read and follow the safety instructions and all other instructions. Keep the manual for future reference. Make sure that it is available to all those using the device. If you sell the unit please make sure that the buyer also receives this manual.

Our products are subject to a process of continuous development. Thus, they are subject to change.

1.1 Further information

On our website (www.thomann.de) you will find lots of further information and details on the following points:

Download	This manual is also available as PDF file for you to download.
Keyword search	Use the search function in the electronic version to find the topics of interest for you quickly.
Online guides	Our online guides provide detailed information on technical basics and terms.
Personal consultation	For personal consultation please contact our technical hotline.
Service	If you have any problems with the device the customer service will gladly assist you.

1.2 Notational conventions

This manual uses the following notational conventions:

Letterings

The letterings for connectors and controls are marked by square brackets and italics.

Examples: *[VOLUME]* control, *[Mono]* button.

Instructions

The individual steps of an instruction are numbered consecutively. The result of a step is indented and highlighted by an arrow.

Example:

1. ➤ Switch on the device.
2. ➤ Press *[Auto]*.
 - ⇒ Automatic operation is started.
3. ➤ Switch off the device.

1.3 Symbols and signal words

In this section you will find an overview of the meaning of symbols and signal words that are used in this manual.

Signal word	Meaning
DANGER!	This combination of symbol and signal word indicates an immediate dangerous situation that will result in death or serious injury if it is not avoided.
WARNING!	This combination of symbol and signal word indicates a possible dangerous situation that can result in death or serious injury if it is not avoided.
NOTICE!	This combination of symbol and signal word indicates a possible dangerous situation that can result in material and environmental damage if it is not avoided.

Warning signs	Type of danger
	Warning – danger zone.

2 Safety instructions

Intended use

This device is intended to be used for the wireless transmission of audio signals from microphones or instruments to amplifiers or active speakers. Use the device only as described in this user manual. Any other use or use under other operating conditions is considered to be improper and may result in personal injury or property damage. No liability will be assumed for damages resulting from improper use.

This device may be used only by persons with sufficient physical, sensorial, and intellectual abilities and having corresponding knowledge and experience. Other persons may use this device only if they are supervised or instructed by a person who is responsible for their safety.

Safety



DANGER!

Danger for children

Ensure that plastic bags, packaging, etc. are disposed of properly and are not within reach of babies and young children. Choking hazard!

Ensure that children do not detach any small parts (e.g. knobs or the like) from the unit. They could swallow the pieces and choke!

Never let children unattended use electrical devices.



NOTICE!

Operating conditions

This device has been designed for indoor use only. To prevent damage, never expose the device to any liquid or moisture. Avoid direct sunlight, heavy dirt, and strong vibrations.



NOTICE!

External power supply

The device is powered by an external power supply. Before connecting the external power supply, ensure that the input voltage (AC outlet) matches the voltage rating of the device and that the AC outlet is protected by a residual current circuit breaker. Failure to do so could result in damage to the device and possibly the user.

Unplug the external power supply before electrical storms occur and when the device is unused for long periods of time to reduce the risk of electric shock or fire.



NOTICE!

Risk of fire due to incorrect polarity

Incorrectly inserted batteries may destroy the device or the batteries.

Ensure that proper polarity is observed when inserting batteries.



NOTICE!

Possible damage by leaking batteries

Leaking batteries can cause permanent damage to the device.

Take batteries out of the device if it is not going to be used for a longer period.



NOTICE!

Possible damage due to incorrect storage

Deep discharge can cause batteries to become permanently damaged or lose some of their capacity.

Before prolonged rest periods, charge the batteries to around 50 % of their capacity and then switch the equipment off. Store the equipment at a temperature between 10 °C and 32 °C in as dry an environment as possible. During extended storage periods, charge the batteries to 50 % approximately every three months.



NOTICE!

Possible staining

The plasticiser contained in the rubber feet of this product may possibly react with the coating of your parquet, linoleum, laminate or PVC floor and after some time cause permanent dark stains.

In case of doubt, do not put the rubber feet directly on the floor, but use felt-pad floor protectors or a carpet.

3 Features

The UHF Wireless System GigA Pro Vocal Set consists of the following components:

- 9.5" Diversity receiver:
 - Two antennas for optimum reception quality
 - Automatic frequency scan, four to six frequencies in parallel
 - Infrared interface for sending the frequency selection from the receiver to the transmitter (ACT sync)
 - Outputs: XLR, 1/4" phone socket
 - Power supply: 12 V $\overline{\text{AC}}$, a suitable power adapter and mounting accessories for installation in a rack are included in the delivery
- Handheld microphone:
 - Condenser microphone with cardioid characteristic
 - Replaceable lithium-ion rechargeable battery operation
 - Charging contacts for battery charging station GigA Pro BC2
 - Three-digit display for battery capacity
 - Infrared interface for ACT sync
- Battery charging station GigA Pro BC2

The system operates at 2.400 GHz ... 2.4835 GHz and is worldwide free of charge and registration.

4 Installation and starting up

4.1 General Information

Unpack and carefully check that there is no transportation damage before using the unit. Keep the equipment packaging. To fully protect the device against vibration, dust and moisture during transportation or storage use the original packaging or your own packaging material suitable for transport or storage, respectively.

Create all connections while the device is off. Use the shortest possible high-quality cables for all connections. Take care when running the cables to prevent tripping hazards.

Notes on wireless transmission

- This device utilizes frequencies that are not harmonized within the European Union (EU) and therefore may only be used in certain EU member states. In all European countries, the frequencies used for the transmission of audio signals are strictly regulated. Before you start, make sure the frequencies are allowed in the respective country and check whether the operation must be reported to the appropriate authority.
For more information, please visit: <http://www.thomann.de>.
- Make sure that transmitter and receiver are both tuned to the same channel.
- Never set multiple transmitters to the same channel.
- Make sure that there are no metal objects between the transmitter and receiver.
- Avoid interference from other radio or in-ear systems.

4.2 Dealing with lithium batteries

**WARNING!****Incorrect handling of lithium batteries can result in injury**

In the event of a short circuit, overheating or mechanical damage, lithium batteries can cause severe injuries.

Follow the advice on the correct handling of lithium batteries in the present section.

When handled correctly and appropriately lithium batteries pose no risk.

Store lithium batteries in a cool, dry place, ideally in the original packaging.

Store lithium batteries away from heat sources (e.g. radiators or sunlight). Lithium batteries are hermetically sealed. Never attempt to open a lithium battery.

If the battery housing is damaged small amounts of the electrolyte may leak out. If this should happen, seal the lithium battery in airtight packaging and wipe up the traces of electrolyte using absorbent paper towels. You must wear protective rubber gloves when doing so. Clean your hands and the affected surface thoroughly with cold water.

Never attempt to recharge non-rechargeable lithium batteries. When charging lithium batteries you must use a suitable charging device intended for the purpose.

Before disposing of the device remove the lithium batteries. Protect used lithium batteries against potential short circuits, e.g. by covering the poles with adhesive tape.

Only use powder extinguishers or other suitable extinguishing agents to extinguish a burning lithium battery.

4.3 Receiver

Rack mounting

The unit has been designed for rack mounting in a standard 19" rack; it occupies one rack unit. The fixing material required for assembly is included.

Connecting the power supply



NOTICE!

External power supply

The device is powered by an external power supply. Before connecting the external power supply, ensure that the input voltage (AC outlet) matches the voltage rating of the device and that the AC outlet is protected by a residual current circuit breaker. Failure to do so could result in damage to the device and possibly the user.

Unplug the external power supply before electrical storms occur and when the device is unused for long periods of time to reduce the risk of electric shock or fire.

First, connect the power adapter to the receiver and then plug the power adapter into the power outlet.

Connecting audio and starting up

Connect one of the audio outputs of the receiver to your mixer or your amplifier. Ensure that only one of the two outputs is ever used at a time, because faults might occur otherwise.

5 Connections and controls

5.1 Receiver

Front panel

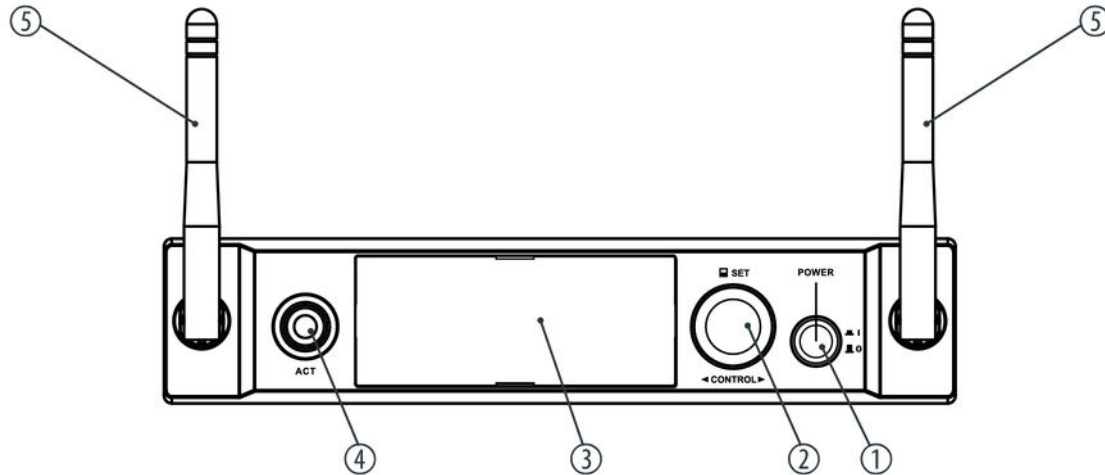

1	<i>[POWER]</i> Press the switch to switch the device on or off. All previous settings are retained even when you switch the device off and disconnect it from the mains.
2	<i>[CONTROL]</i> Press the jog wheel to open the menu and rotate it to select a menu item. Press the jog wheel again to call up the menu item.
3	Display
4	<i>[ACT]</i> Starts the synchronization of the settings with the transmitter.
5	Antenna

Rear panel

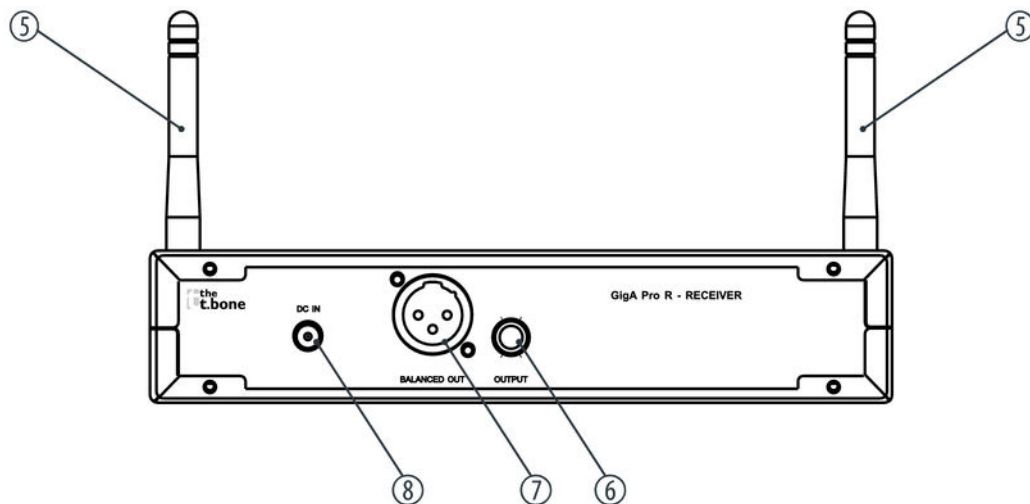

5	Antenna
6	<i>[OUTPUT]</i> 1/4" phone socket as unbalanced audio signal output for direct connection to a mixer, a power amplifier or recording device.
7	<i>[BALANCED OUT]</i> Male XLR panel connector as symmetrical audio signal output for direct connection with a mixer, a power amplifier, or a recording device.
8	<i>[DC IN]</i> Socket for connecting the supplied AC power supply. If you are using a different power supply, observe the correct voltage, the polarity of the plug and the power consumption.

Display

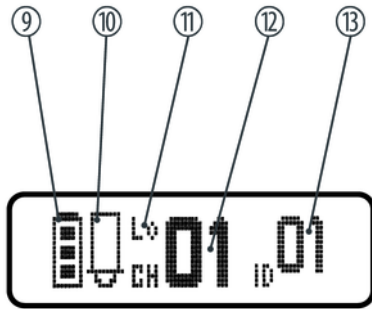

9	Shows the battery status of the transmitter from which the device just received a signal.
10	Level display for the audio signal.
11	Current status of output power ('Lo': low level; 'Hi': high level).
12	[CH] Indicates the selected channel.
13	[ID] Indicates the set ID.

Display during automatic channel evaluation

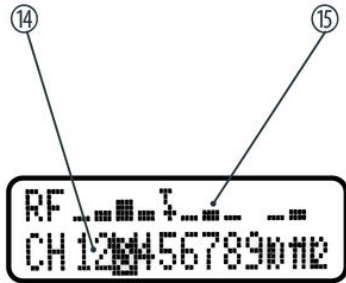

14 [CH]

Available channel numbers. The channel currently selected with the jog wheel is highlighted.

15 [RF]

Current evaluation result. Here, the vertical bars indicate how strong the interferences on the respective channel are. The 'T+' symbol indicates the currently used channel. The 'T!' symbol is displayed for channels that are occupied by other devices. The symbols flash for the channel currently being tested.

5.2 Handheld microphone

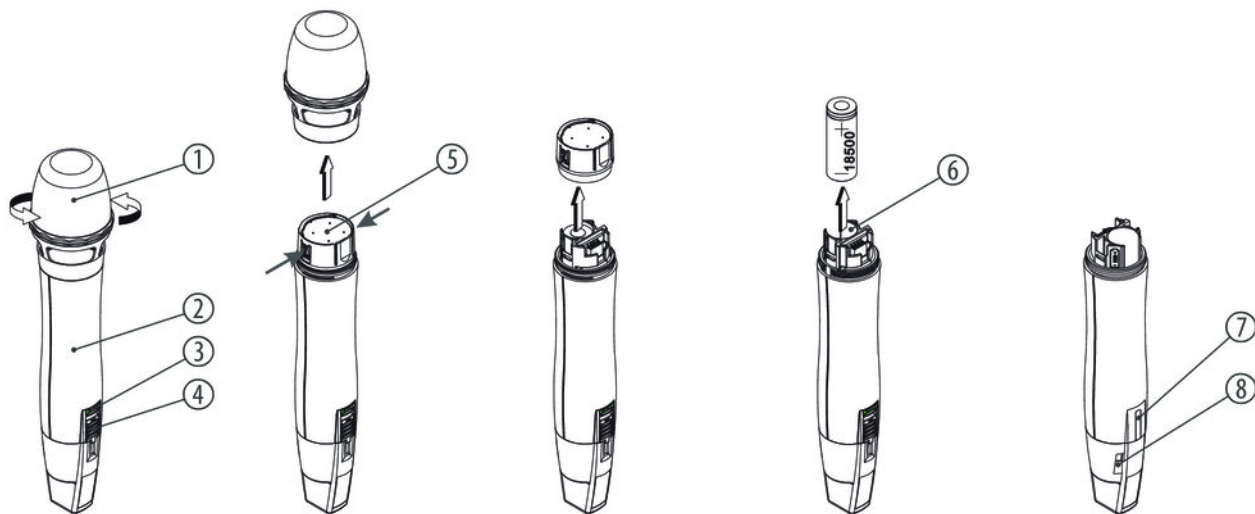

1	Microphone capsule with detachable head grill to prevent damage and to reduce wind and breath noise.
2	Lower housing part.
3	Battery status indicator If the last remaining segment lights up red, at most 25% of the battery capacity remains.
4	<i>[ON]</i> Main switch
5	Battery compartment cover.
6	Battery compartment
7	<i>[ACT]</i> Infrared sensor
8	Charging contacts.

5.3 Rechargeable battery station

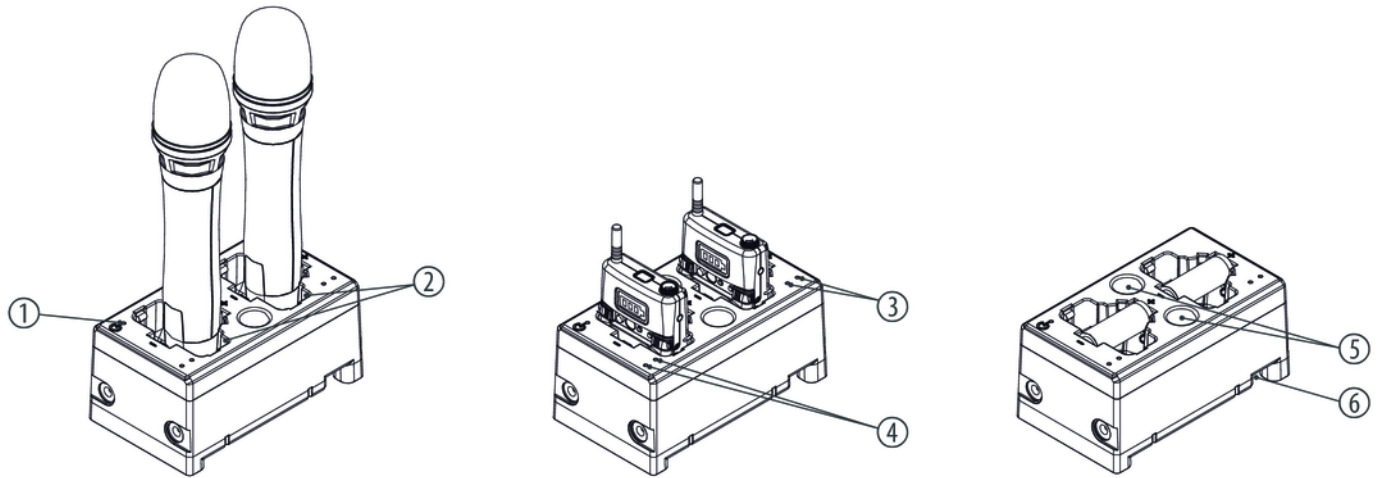

1	Power indicator. Lights up when the device is connected to the power supply.
2	Combined charging bays, suitable for handheld microphones, Bodypack transmitters and type ICR-18500 rechargeable lithium-ion batteries.
3,4	Charging indicator for both charging bays. The red LED lights during charging, while the green LED will light up when the device is charged.
5	Storage options for IMR-18500 type lithium-ion batteries.
6	Connector for the supplied power supply adapter.

6 Operating

6.1 Receiver

Select channel

1. ▶ Press the jog wheel to open the main menu.
2. ▶ Turn the jog wheel until the menu item 'CH:xxx' appears.
Press the jog wheel to call up the menu item.
⇒ The last selected channel number is displayed.
3. ▶ Use the jog wheel to select a channel.
Press the jog wheel to confirm the selection.
⇒ The menu is closed, the display shows the set value.

ID selecting

The ID adjustable in addition to the channel increases the transmission reliability.

- 1.** ▶ Press the jog wheel to open the main menu.
- 2.** ▶ Turn the jog wheel until the menu item '*ID:xxx*' appears.
Press the jog wheel to call up the menu item.
⇒ The last selected channel number is displayed.
- 3.** ▶ Use the jog wheel to select an ID.
Press the jog wheel to confirm the selection.
⇒ The menu is closed, the display shows the set value.

Synchronizing transmitter and receiver

1. ➤ Switch the transmitter on and hold it in way that the infrared sensor points towards the receiver.
2. ➤ Press *[ACT]*.
 - ⇒ The message 'ACT...' in the display indicates that the synchronization is running.
3. ➤ After successful synchronization, the display appears in the default state. The battery status of the transmitter with which you just synchronized is now displayed here.

If the synchronization has failed, the message 'FAIL' appears. In this case, hold the transmitter closer to the receiver and restart the synchronization.

Adjusting radio signal level

- 1.** ▶ Press the jog wheel to open the main menu.
- 2.** ▶ Turn the jog wheel until the menu item *'TX: Hi - Lo'* appears.
Press the jog wheel to call up the menu item.
⇒ The last selected setting is displayed.
- 3.** ▶ Use the jog wheel to select either a high (*'HIGH'*) or a low level (*'LOW'*).
Press the jog wheel to confirm the selection.
⇒ The menu is closed, the display shows the set value.

Setting bass filter

- 1.** ▶ Press the jog wheel to open the main menu.
- 2.** ▶ Turn the jog wheel until the menu item 'EQ: F-LC' appears.
Press the jog wheel to call up the menu item.
⇒ The last selected setting is displayed.
- 3.** ▶ Use the jog wheel to turn the bass filter on ('LOW-CUT') or off ('FLAT'). The filter is used to suppress annoying hum or rumbling noises.
Press the jog wheel to confirm the selection.
⇒ The menu is closed.

Automatic channel evaluation

1. ▶ Press the jog wheel to open the main menu.
2. ▶ Turn the jog wheel until the menu item 'SCAN' appears.
Press the jog wheel to start the automatic channel evaluation.
 - ⇒ The evaluation result is displayed. Here, the vertical bars indicate how strong the interferences on the respective channel are. The 'T+' symbol indicates the currently used channel. The 'T!' symbol is displayed for channels that are occupied by other devices. The symbols flash for the channel currently being tested.
3. ▶ If you want to change the channel, use the jog wheel to select the channel with the lowest interferences.
Press the jog wheel to confirm the selection.
 - ⇒ The automatic channel evaluation is terminated, the menu is closed.

6.2 Handheld microphone

Engaging transmitter

1. ▶ Slide the main switch *[ON]* upwards.
⇒ The battery level indicator lights up.
2. ▶ If the last remaining segment of the battery level indicator lights up red, at most 25 % of the battery capacity remains.
In this case, recharge the handheld microphone in the charger or replace the empty battery with a charged one.

Turning the transmitter off

Slide the main switch *[ON]* downwards; the battery level indicator goes out.

Battery replacement

1. ▶ Turn the handheld microphone off.
2. ▶ Unscrew the microphone capsule.
3. ▶ Press the two side latches of the battery compartment cover together and gently pull the cover upwards.
4. ▶ Remove the empty battery and replace it with a charged one. Observe the correct polarity. The positive pole points upwards.
5. ▶ Replace the battery compartment cover and screw the microphone capsule back on.

7 Technical specifications

7.1 Receiver

Output	XLR chassis plug, balanced 1/4" phone socket (unbalanced)
Output level adjustment	-10 dB ... +20 dB
Frequency range	2.400 GHz ... 2.4835 GHz
Sensitivity	-95 dBm
Audio sampling rate	24 bit / 44.1 kHz
NF frequency response	20 Hz ... 20 kHz (-2 dB)
THD (1 kHz)	0.1 %
Signal-to-noise ratio	> 115 dB (A)
Voltage supply	12 – 15 V $\overline{\text{DC}}$, 1000 mA

Power consumption	1.6 W
Dimensions (W × H × D, without antennas)	210 mm × 44 mm × 180 mm (1 RU)
Weight	0.75 kg

7.2 Handheld microphone

Frequency range	2.400 GHz ... 2.4835 GHz
Maximum transmission power	10 mW
Maximum input level	6.5 dBV
Input impedance	1,0 MΩ
Voltage supply	1 lithium-ion rechargeable battery ICR-18500
Operating time	> 10 h (after four hours charging time), > 1 h (after 25 minutes charging time)

Dimensions (L × D)	248 mm × 50 mm
Weight (without battery)	255 g

7.3 Rechargeable battery station

Suitable for	Lithium-ion rechargeable battery ICR-18500, 3.7 V
Charging method	Electronic control
Charging current	approx. 500 mA
Voltage supply	10 – 15 V $\overline{=}$ via the supplied power adapter
Current consumption	approx. 600 mA when charging two batteries at a time
Dimensions (W × H × D)	92 mm × 78 mm × 158 mm
Weight	313 g

8 Plug and connection assignment

Introduction

This chapter will help you select the right cables and plugs to connect your valuable equipment in such a way that a perfect sound experience is ensured.

Please note these advices, because especially in 'Sound & Light' caution is indicated: Even if a plug fits into the socket, an incorrect connection may result in a destroyed power amp, a short circuit or 'just' in poor transmission quality!

Balanced and unbalanced transmission

Unbalanced transmission is mainly used in semi-professional environment and in hifi use. Instrument cables with two conductors (one core plus shielding) are typical representatives of the unbalanced transmission. One conductor is ground and shielding while the signal is transmitted through the core.

Unbalanced transmission is susceptible to electromagnetic interference, especially at low levels, such as microphone signals and when using long cables.

In a professional environment, therefore, the balanced transmission is preferred, because this enables an undisturbed transmission of signals over long distances. In addition to the conductors 'Ground' and 'Signal', in a balanced transmission a second core is added. This also transfers the signal, but phase-shifted by 180°.

Since the interference affects both cores equally, by subtracting the phase-shifted signals, the interfering signal is completely neutralized. The result is a pure signal without any noise interference.

1/4" TS phone plug (mono, unbalanced)



1	Signal
2	Ground, shielding

XLR plug (balanced)

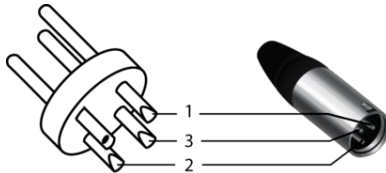

1	Ground, shielding
2	Signal (in phase, +)
3	Signal (out of phase, -)

9 Troubleshooting

In the following we list a few common problems that may occur during operation. We give you some suggestions for easy troubleshooting:

Symptom	Remedy
No sound	<ol style="list-style-type: none"><li data-bbox="632 244 1517 288">1. Check the power supply of transmitter and receiver.<li data-bbox="632 291 1517 364">2. Make sure that transmitter and receiver are operating in the same frequency range. The frequency range can be found on the devices.<li data-bbox="632 366 1517 411">3. Are transmitter and receiver set to the same channel and ID?<li data-bbox="632 413 1517 553">4. Test the connection between the receiver and the connected audio device (amplifier, mixer). Is the connected audio device turned on and does the signal level at the output of the receiver match the input requirements of the audio device?<li data-bbox="632 555 1517 628">5. See if the audio transmission works when you move the transmitter closer to the receiver.<li data-bbox="632 630 1517 703">6. Make sure that no metal objects near the transmitter or receiver obstruct the transmission.
Transmission is interrupted.	<ol style="list-style-type: none"><li data-bbox="632 717 1517 762">1. Modify the orientation of the antennas.<li data-bbox="632 764 1517 837">2. If you use more than one wireless system at the same time, check the used frequencies and channels.<li data-bbox="632 840 1517 879">3. Interference can also be caused by other radio or in-ear systems.

If the procedures recommended above do not succeed, please contact our Service Center. You can find the contact information at www.thomann.de.

10 Protecting the environment

Disposal of the packaging material



For the packaging, environmentally friendly materials have been chosen that can be supplied to normal recycling.

Ensure that plastic bags, packaging, etc. are properly disposed of.

Do not just dispose of these materials with your normal household waste, but make sure that they are collected for recycling. Please follow the notes and markings on the packaging.

Disposal of batteries



Batteries do contain some hazardous chemicals so they should not be thrown away with the normal household waste. They should be returned to the manufacturer for disposal or recycled elsewhere in accordance with your local regulations.

Remove lithium batteries from the device before disposal. Protect used lithium batteries against short circuit, for example by taping the poles.

Disposal of your old device



This product is subject to the European Waste Electrical and Electronic Equipment Directive (WEEE) in its currently valid version. Do not dispose with your normal household waste.

Dispose of this device through an approved waste disposal firm or through your local waste facility. When discarding the device, comply with the rules and regulations that apply in your country. If in doubt, consult your local waste disposal facility.



