



Achat 112 A

Active Speaker

Thomann GmbH

Hans-Thomann-Straße 1

96138 Burgebrach

Germany

Telephone: +49 (0) 9546 9223-0

Internet: [www.thomann.de](http://www.thomann.de)

24.05.2024, ID: 325263 (V4)

---

## Table of contents

<b>1</b>	<b>General information</b> .....	<b>5</b>
	1.1 Symbols and signal words.....	5
<b>2</b>	<b>Safety instructions</b> .....	<b>8</b>
<b>3</b>	<b>Features</b> .....	<b>11</b>
<b>4</b>	<b>Installation</b> .....	<b>12</b>
	4.1 Tips on handling speakers.....	15
	4.2 Hanging the speaker box.....	15
<b>5</b>	<b>Connections and controls</b> .....	<b>16</b>
<b>6</b>	<b>Technical specifications</b> .....	<b>18</b>
<b>7</b>	<b>Plug and pin assignments</b> .....	<b>23</b>
<b>8</b>	<b>Protecting the environment</b> .....	<b>25</b>



**4** Achat 112 A  
Active Speaker



# 1 General information

This document contains important instructions for the safe operation of the product. Read and follow the safety instructions and all other instructions. Keep the document for future reference. Make sure that it is available to all those using the product. If you sell the product to another user, be sure that they also receive this document.

Our products and documentation are subject to a process of continuous development. They are therefore subject to change. Please refer to the latest version of the documentation, which is ready for download under [www.thomann.de](http://www.thomann.de).

## 1.1 Symbols and signal words

In this section you will find an overview of the meaning of symbols and signal words that are used in this document.

Signal word	Meaning
<b>DANGER!</b>	This combination of symbol and signal word indicates an immediate dangerous situation that will result in death or serious injury if it is not avoided.
<b>WARNING!</b>	This combination of symbol and signal word indicates a possible dangerous situation that can result in death or serious injury if it is not avoided.
<b>CAUTION!</b>	This combination of symbol and signal word indicates a possible dangerous situation that can result in minor injury if it is not avoided.
<b>NOTICE!</b>	This combination of symbol and signal word indicates a possible dangerous situation that can result in material and environmental damage if it is not avoided.
Warning signs	Type of danger
	Warning – high-voltage.
	Warning – suspended load.

Warning signs	Type of danger
	Warning – danger zone.

## 2 Safety instructions

### Intended use

This device is designed for sound reinforcement. Use the device only as described in this user manual. Any other use or use under other operating conditions is considered to be improper and may result in personal injury or property damage. No liability will be assumed for damages resulting from improper use.

This device may be used only by persons with sufficient physical, sensorial, and intellectual abilities and having corresponding knowledge and experience. Other persons may use this device only if they are supervised or instructed by a person who is responsible for their safety.

### Safety



#### **DANGER!**

#### **Risk of injury and choking hazard for children!**

Children can suffocate on packaging material and small parts. Children can injure themselves when handling the device. Never allow children to play with the packaging material and the device. Always store packaging material out of the reach of babies and small children. Always dispose of packaging material properly when it is not in use. Never allow children to use the device without supervision. Keep small parts away from children and make sure that the device does not shed any small parts (such knobs) that children could play with.



#### **DANGER!**

#### **Danger to life due to electric current!**

A short circuit could lead to a fire hazard and risk of death. Always use proper ready-made insulated triple-core mains cable with a safety plug. Do not modify the mains cable or the plug. In case of isolation damage, disconnect immediately the power supply and arrange repair. If in doubt, seek advice from a qualified electrician.



**DANGER!****Danger to life due to electric current!**

Within the device there are areas where high voltages may be present. Never remove any covers. There are no user-serviceable parts inside. Do not use the device when covers, safety equipment or optical components are missing or damaged.

**WARNING!****Possible hearing damage due to operating the device at a high volume!**

The device can produce volume levels that, when operated at a high volume, may cause temporary or permanent hearing impairment. Over an extended period of time, even levels that seem to be uncritical can cause hearing damage. Avoid operating the device at excessively high volumes over an extended period of time. Decrease the volume level immediately if you experience ringing in your ears or hearing impairment. If this is not possible, keep a greater distance or use adequate ear-muffs.

**CAUTION!****Risk of injury due to heavy weight!**

The device is heavy. Lifting and dropping it during transport and installation can cause injuries. Make sure at least two people work together when transporting and installing the device.

**NOTICE!****Risk of fire due to covered vents and neighbouring heat sources!**

If the vents of the device are covered or the device is operated in the immediate vicinity of other heat sources, the device can over-heat and burst into flames. Never cover the device or the vents. Do not install the device in the immediate vicinity of other heat sources. Never operate the device in the immediate vicinity of naked flames.



### **NOTICE!**

#### **Damage to the device if operated in unsuitable ambient conditions!**

The device can be damaged if it is operated in unsuitable ambient conditions. Only operate the device indoors within the ambient conditions specified in the "Technical specifications" chapter of this user manual. Avoid operating it in environments with direct sunlight, heavy dirt and strong vibrations. Avoid operating it in environments with strong temperature fluctuations. If temperature fluctuations cannot be avoided (for example after transport in low outside temperatures), do not switch on the device immediately. Never subject the device to liquids or moisture. Never move the device to another location while it is in operation. In environments with increased dirt levels (for example due to dust, smoke, nicotine or mist): Have the device cleaned by qualified specialists at regular intervals to prevent damage due to overheating and other malfunctions.



### **NOTICE!**

#### **Damage to the device due to high voltages!**

The device can be damaged if it is operated with the incorrect voltage or if high voltage peaks occur. In the worst case, excess voltages can also cause a risk of injury and fires. Make sure that the voltage specification on the device matches the local power grid before plugging in the device. Only operate the device from professionally installed mains sockets that are protected by a residual current circuit breaker (FI). As a precaution, disconnect the device from the power grid when storms are approaching or if the device will not be used for a longer period.



### **NOTICE!**

#### **Possible staining due to plasticiser in rubber feet!**

The plasticiser contained in the rubber feet of this product may react with the coating of the floor and cause permanent dark stains after some time. If necessary, use a suitable mat or felt slide to prevent direct contact between the device's rubber feet and the floor.

## 3 Features

Special characteristics of the active horn-loaded 2-way mid-high speaker with built-in cross-over:

- 12-inch woofer
- 1.4-inch mid-level tweeter
- Beam angle  $60^\circ \times 40^\circ$
- Connection options:
  - 1 × XLR input/output
- 35-mm pole flange on the bottom
- Truss tracks on top of the housing and an eye on the back for tilting. Mounting for vertical suspension optionally available.
- Black textured paint
- Protective cover (optional, item no. 222251)
- Casters (optional, item no. 243578)

## 4 Installation

Unpack and check carefully there is no transportation damage before using the unit. Keep the equipment packaging. To fully protect the product against vibration, dust and moisture during transportation or storage use the original packaging or your own packaging material suitable for transport or storage, respectively.

Create all connections while the device is off. Use the shortest possible high-quality cables for all connections. Take care when running the cables to prevent tripping hazards.



### **WARNING!**

#### **Risk of injury from falling devices that were inadequately secured!**

If devices are not properly secured during assembly, they can cause severe injury and considerable damage by falling.

When installing and operating, make sure to follow the standards and regulations that apply in your country.

Always secure the device with a secondary safety attachment, such as a safety cable or a safety chain.



**WARNING!**

**Risk of injury due to improper installation!**

Improper mounting can lead to serious injuries and significant damage to property.

When installing and operating, make sure to follow the standards and regulations that apply in your country. In Germany, this is DGUV regulation 17 “Staging and Production Facilities for the Entertainment Industry”.

Ensure that speakers are only mounted by trained specialists.



**CAUTION!**

**Risk of injury due to heavy weight!**

The device is heavy. Lifting and dropping it during transport and installation can cause injuries.

Make sure at least two people work together when transporting and installing the device.



### **NOTICE!**

#### **Possible property damage to adjacent devices due to magnetic fields.**

Speakers generate a static magnetic field. This magnetic field can affect other neighbouring units and in unfavourable cases damage them.

Ensure that speakers are always a sufficient distance away from sensitive equipment that may be affected by an external magnetic field.



### **NOTICE!**

#### **Potential property damage due to unsuitable stands!**

If the device is mounted on an unsuitable stand, there is a risk that the stand will fall over and cause damage.

Only use stands whose maximum bearing capacity is at least as high as the weight of the device. Always ensure that the stand is stable.

## 4.1 Tips on handling speakers

We recommend you to set up the speakers in a way, that the sound signals can reach the audience unobstructedly. It will often be helpful to mount the speakers on tripods. Thus, the sound will be evenly spread with maximum range throughout the audience area.

Always use high grade cable to connect your equipment. Otherwise you won't reach maximum sound quality.

If you notice distortion during operation, the active speaker is overloaded. This may permanently damage the device. Always reduce the volume as soon as you hear distortion.

## 4.2 Hanging the speaker box

To hang the speaker box on special mounting devices (aka 'flying'), the top of the box offers built-in Aeroquip or fly tracks. In these tracks safety eyelets (double studs) can be screwed or latched. Check the secure connection of the safety eyelets with the box carefully, before you use it in 'flying mode'.

Using an additional loop on the back of the box, it is possible to tilt the box. This additional loop must not solely be in charge to secure the entire suspended weight.

## 5 Connections and controls

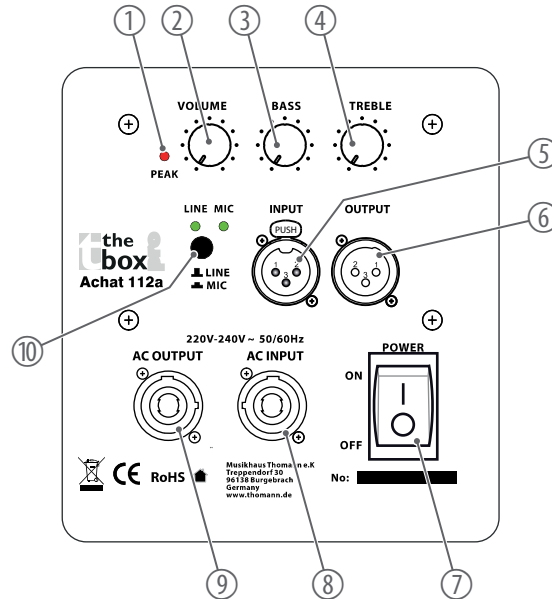



1	<i>[PEAK]</i> LED   Indicates overload. If the LED flickers or lights up, the input signal level is too high.
2	<i>[VOLUME]</i>   Control for adjusting the volume. Turn the control clockwise to increase the volume and anti-clockwise to decrease the volume.
3	<i>[BASS]</i>   Bass control. Turn the control clockwise for a sound with more bass. Turn the control anti-clockwise to decrease the bass.
4	<i>[TREBLE]</i>   Treble control. Turn the control clockwise for a sound with more treble. Turn the control anti-clockwise to decrease the treble.
5	<i>[INPUT]</i>   Signal input with switchable sensitivity, designed as XLR panel socket.
6	<i>[OUTPUT]</i>   Line output for connecting further active speakers, designed as XLR panel plug.
7	<i>[POWER ON/OFF]</i>   Mains switch for turning the device on and off.
8	<i>[AC INPUT]</i>   Blue lockable input socket (Power Twist).
9	<i>[AC OUTPUT]</i>   Grey lockable output socket (Power Twist). This output is looped through from the blue <i>[AC INPUT]</i> socket. It can be used to connect the power supply for further elements with their respective <i>[AC INPUT]</i> sockets.
10	<i>[LINE/MIC]</i>   Pushbutton for selecting the input sensitivity of the speaker (line or microphone level). <i>[MIC]</i> LED   The LED lights up in operation if the input sensitivity is set to MIC. <i>[LINE]</i> LED   The LED lights up in operation if the input sensitivity is set to LINE.

## 6 Technical specifications

System	Active 2-way speaker	
Configuration	12-inch woofer	
	1.4-inch mid-level tweeter	
Input connections	Line/Mic	1 × XLR (balanced)
	Power supply	1 × Power Twist
Input impedance	Line	100 k $\Omega$ (balanced)
		50 k $\Omega$ (unbalanced)
	Microphone	1 k $\Omega$
Output connections	Line	1 × XLR (balanced)
	Power supply for further devices	1 × Power Twist
Output power	RMS: 600 W	
	Peak: 2400 W	
Frequency range	200 Hz ... 16 kHz, -3 dB	
Crossover frequency	2 kHz	
Rated impedance	8 $\Omega$	

Sound pressure level (SPL), max.	138 dB	
Signal-to-noise ratio	Woofer	≥90 dB (630 Hz, typical)
	Tweeter	≥88 dB (6.3 kHz, typical)
Total harmonic distortion (THD)	≤ 0.5%, in normal operation at 100 Hz	
Beam angle (H × V)	60° × 40°	
Power consumption	20 W	
Supply voltage	230 V ~ 50 Hz	
Dimensions (W × H × D)	550 mm × 600 mm × 718 mm	
Weight	43 kg	
Ambient conditions	Temperature range	0 °C...40 °C
	Relative humidity	20%...80% (non-condensing)

### Further information

Housing	Wood
Colour	Black
Truss-capable	Truss rail
Monitor inclination	No
Ways	2-way
Stand flange	35 mm
Wall mount	No
Protective cover	Optional (item no. 222251)
Casters	Optional (item no. 243578)

## Frequency response

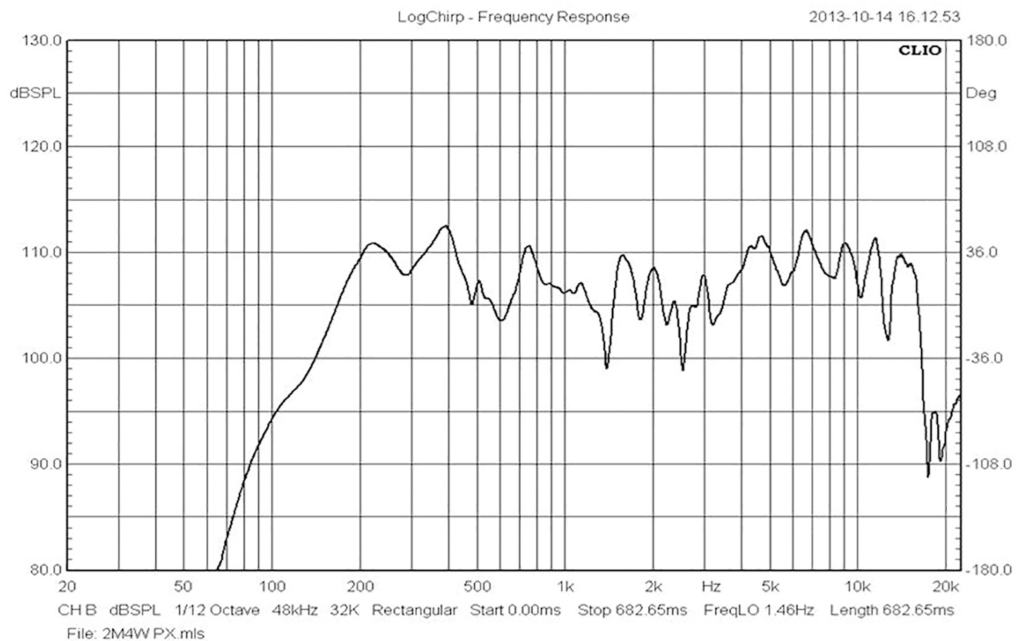

## Dimensions

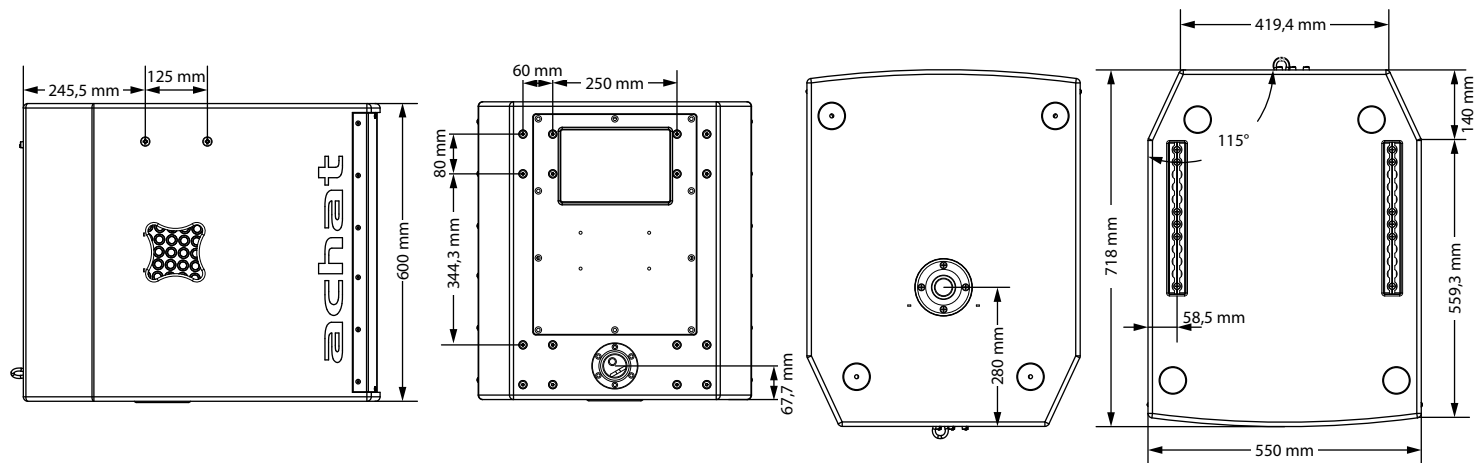

## 7 Plug and pin assignments

### Introduction

This chapter will help you select the right cables and plugs to connect your valuable equipment in such a way that a perfect sound experience is ensured.

Please note these advices, because especially in 'Sound & Light' caution is indicated: Even if a plug fits into the socket, an incorrect connection may result in a destroyed power amp, a short circuit or 'just' in poor transmission quality!

### Balanced and unbalanced transmission

Unbalanced transmission is mainly used in semi-professional environment and in hifi use. Instrument cables with two conductors (one core plus shielding) are typical representatives of the unbalanced transmission. One conductor is ground and shielding while the signal is transmitted through the core.

Unbalanced transmission is susceptible to electromagnetic interference, especially at low levels, such as microphone signals and when using long cables.

In a professional environment, therefore, the balanced transmission is preferred, because this enables an undisturbed transmission of signals over long distances. In addition to the conductors 'Ground' and 'Signal', in a balanced transmission a second core is added. This also transfers the signal, but phase-shifted by 180°.

Since the interference affects both cores equally, by subtracting the phase-shifted signals, the interfering signal is completely neutralized. The result is a pure signal without any noise interference.

## XLR plug (balanced)

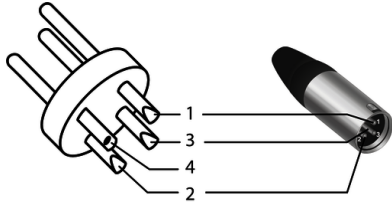

1	Ground, shielding
2	Signal (in phase, +)
3	Signal (out of phase, -)
4	Shielding on plug housing (option)

## XLR plug (unbalanced)

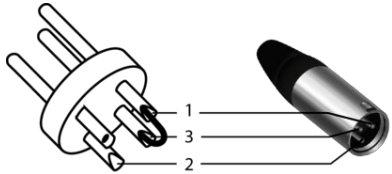

1	Ground, shielding
2	Signal
3	Bridged to pin 1



## 8 Protecting the environment

### Disposal of the packing material

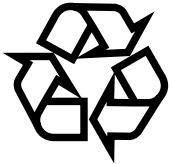

Environmentally friendly materials have been chosen for the packaging. These materials can be sent for normal recycling. Ensure that plastic bags, packaging, etc. are disposed of in the proper manner.

Do not dispose of these materials with your normal household waste, but make sure that they are collected for recycling. Please follow the instructions and markings on the packaging.

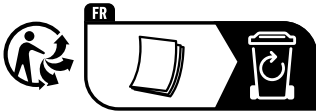

Observe the disposal note regarding documentation in France.

### Disposal of your old device

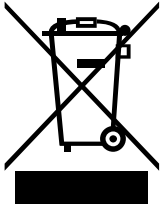

This product is subject to the European Waste Electrical and Electronic Equipment Directive (WEEE) as amended.

Do not dispose of your old device with your normal household waste; instead, deliver it for controlled disposal by an approved waste disposal firm or through your local waste facility. If in doubt, consult your local waste management facility. You can also return the device to a retailer if they offer to take the device back for free or if they are legally obliged to do so. When disposing of the device, comply with the rules and regulations that apply in your country. You can also return your old device to Thomann GmbH at no charge. Check the current conditions on [www.thomann.de](http://www.thomann.de).

Proper disposal protects the environment as well as the health of your fellow human beings. This is because the proper handling of old devices negates the potential negative effects of hazardous substances, and because it conserves resources by recycling them.

Also note that waste avoidance is a valuable contribution to environmental protection. Repairing a device or passing it on to another user is an ecologically valuable alternative to disposal.

If your old device contains personal data, delete those data before disposing of it.



