



Show Bar TriLED 18x3W RGB,  
Show Bar TriLED 18x3W RGB WH

LED Floodlight

Thomann GmbH

Hans-Thomann-Straße 1

96138 Burgebrach

Germany

Telephone: +49 (0) 9546 9223-0

Internet: [www.thomann.de](http://www.thomann.de)

23.08.2022, ID: 326889, 343966 (V3)

# Table of contents

<b>1</b>	<b>General information.....</b>	<b>6</b>
	1.1 Further information.....	7
	1.2 Notational conventions.....	7
	1.3 Symbols and signal words.....	8
<b>2</b>	<b>Safety instructions.....</b>	<b>10</b>
<b>3</b>	<b>Features.....</b>	<b>13</b>
<b>4</b>	<b>Installation.....</b>	<b>14</b>
<b>5</b>	<b>Starting up.....</b>	<b>16</b>
<b>6</b>	<b>Connections and operating elements.....</b>	<b>18</b>
<b>7</b>	<b>Operating.....</b>	<b>20</b>
	7.1 Starting the device.....	20
	7.2 Main menu.....	20
	7.3 Menu overview.....	27
	7.4 Functions in 2-channel DMX mode.....	28
	7.5 Functions in 3-channel DMX mode.....	29
	7.6 Functions in 5-channel DMX mode.....	29
	7.7 Functions in 7-channel DMX mode.....	30
	7.8 Functions in 18-channel DMX mode.....	32
	7.9 Functions in 27-channel DMX mode.....	33

	7.10 Functions in 54-channel DMX mode.....	35
<b>8</b>	<b>Technical specifications.....</b>	<b>37</b>
<b>9</b>	<b>Plug and connection assignments.....</b>	<b>39</b>
<b>10</b>	<b>Troubleshooting.....</b>	<b>40</b>
<b>11</b>	<b>Cleaning.....</b>	<b>43</b>
<b>12</b>	<b>Protecting the environment.....</b>	<b>44</b>



Show Bar TriLED 18x3W RGB, Show Bar TriLED 18x3W RGB WH  
LED Floodlight

# 1 General information

This user manual contains important information on the safe operation of the device. Read and follow all safety notes and all instructions. Save this manual for future reference. Make sure that it is available to all persons using this device. If you sell the device to another user, be sure that they also receive this manual.

Our products and user manuals are subject to a process of continuous development. We therefore reserve the right to make changes without notice. Please refer to the latest version of the user manual which is ready for download under [www.thomann.de](http://www.thomann.de).

## 1.1 Further information

On our website ([www.thomann.de](http://www.thomann.de)) you will find lots of further information and details on the following points:

Download	This manual is also available as PDF file for you to download.
Keyword search	Use the search function in the electronic version to find the topics of interest for you quickly.
Online guides	Our online guides provide detailed information on technical basics and terms.
Personal consultation	For personal consultation please contact our technical hotline.
Service	If you have any problems with the device the customer service will gladly assist you.

## 1.2 Notational conventions

This manual uses the following notational conventions:

### Letterings

The letterings for connectors and controls are marked by square brackets and italics.

**Examples:** *[VOLUME]* control, *[Mono]* button.

### Displays

Texts and values displayed on the device are marked by quotation marks and italics.





**Examples:** '24ch', 'OFF'.

## 1.3 Symbols and signal words

In this section you will find an overview of the meaning of symbols and signal words that are used in this manual.

Signal word	Meaning
<b>DANGER!</b>	This combination of symbol and signal word indicates an immediate dangerous situation that will result in death or serious injury if it is not avoided.
<b>WARNING!</b>	This combination of symbol and signal word indicates a possible dangerous situation that can result in death or serious injury if it is not avoided.
<b>NOTICE!</b>	This combination of symbol and signal word indicates a possible dangerous situation that can result in material and environmental damage if it is not avoided.



Warning signs	Type of danger
	Warning – high-voltage.
	Warning – dangerous optical radiation.
	Warning – suspended load.
	Warning – danger zone.

## 2 Safety instructions

### Intended use

This device is intended for use as an electronic lighting effect by means of LED technology. The device is designed for professional use only and is not suitable for use in households. Use the device only as described in this user manual. Any other use or use under other operating conditions is considered to be improper and may result in personal injury or property damage. No liability will be assumed for damages resulting from improper use.

This device may be used only by persons with sufficient physical, sensorial, and intellectual abilities and having corresponding knowledge and experience. Other persons may use this device only if they are supervised or instructed by a person who is responsible for their safety.



*Extend the operating life of the device by regular breaks and by avoiding frequent switching on and off. The device is not suitable for continuous operation.*

### Safety



#### **DANGER!**

#### **Danger for children**

Ensure that plastic bags, packaging, etc. are disposed of properly and are not within reach of babies and young children. Choking hazard! Ensure that children do not detach any small parts (e.g. knobs or the like) from the unit. They could swallow the pieces and choke! Never let children unattended use electrical devices.



**DANGER!**

**Electric shock caused by high voltages inside**

Within the device there are areas where high voltages may be present. Never remove any covers. There are no user-serviceable parts inside. Do not use the device if covers, protectors or optical components are missing or damaged.



**DANGER!**

**Electric shock caused by short-circuit**

Always use proper ready-made insulated mains cabling (power cord) with a protective contact plug. Do not modify the mains cable or the plug. Failure to do so could result in electric shock/death or fire. If in doubt, seek advice from a registered electrician.



**WARNING!**

**Eye damage caused by high light intensity**

Never look directly into the light source.



**WARNING!**

**Risk of epileptic shock**

Strobe lighting can trigger seizures in photosensitive epilepsy. Sensitive persons should avoid looking at strobe lights.



**NOTICE!**

**Risk of fire**

Do not block areas of ventilation. Do not install the device near any direct heat source. Keep the device away from naked flames.



### **NOTICE!**

#### **Operating conditions**



This device has been designed for indoor use only. To prevent damage, never expose the device to any liquid or moisture. Avoid direct sunlight, heavy dirt, and strong vibrations. Only operate the device within the ambient conditions specified in the chapter 'Technical specifications' of this user manual. Avoid heavy temperature fluctuations and do not switch the device on immediately after it was exposed to temperature fluctuations (for example after transport at low outside temperatures). Dust and dirt inside can damage the unit. When operated in harmful ambient conditions (dust, smoke, nicotine, fog, etc.), the unit should be maintained by qualified service personnel at regular intervals to prevent overheating and other malfunction.



### **NOTICE!**

#### **Power supply**



Before connecting the device, ensure that the input voltage (AC outlet) matches the voltage rating of the device and that the AC outlet is protected by a residual current circuit breaker. Failure to do so could result in damage to the device and possibly injure the user. Unplug the device before electrical storms occur and when it is unused for long periods of time to reduce the risk of electric shock or fire.



### **NOTICE!**

#### **Fire hazard due to exceedance of the maximum current**



The device can power other devices of identical construction. The current consumption of all other devices connected in series must not exceed the values indicated in the technical specifications. Otherwise you risk injuries and irreparable damages to the device. Only connect so many identical devices that the maximum current consumption is not exceeded. Ensure the sufficient dimensioning (wire cross section) of the power cables used for all devices connected in series.



### **NOTICE!**

#### **Possible damage due to installation of a wrong fuse**



The use of different types of fuses can cause serious damage to the unit. Fire hazard! Only fuses of the same type may be used.

### 3 Features

The LED floodlight is particularly suitable for lighting applications in clubs and discotheques, on rock stages, in theatres and musicals. It can also be used for effect lighting of stage backgrounds or framing catwalks.

Special features of the device:

- 18 tri-colour LEDs (3 W each)
- Control via DMX (seven different modes) and via buttons and display on the unit
- 25 preprogrammed automatic shows
- Sound control
- Master / Slave mode
- Robust metal housing with compact design
- Versatile placement and mounting options
- Looped through mains voltage output for powering further devices

For technological reasons, the light output of LEDs decreases over their lifetime. This effect increases with higher operating temperature. You can extend the service life of the illuminants by providing adequate ventilation and operating the LEDs with the lowest possible brightness.

## 4 Installation

Unpack and check carefully there is no transportation damage before using the unit. Keep the equipment packaging. To fully protect the product against vibration, dust and moisture during transportation or storage use the original packaging or your own packaging material suitable for transport or storage, respectively.

You can install the device on the wall, the ceiling or on the floor. The package includes:

- A removable and adjustable mounting bracket with locking screws mounted on a horizontally slidable carriage. Remove the side plate of the device to remove the carriage completely.
- Two adjustable angle brackets with locking screws; the angle brackets can also be used as pedestals.



### **WARNING!**

#### **Risk of injury caused by falling objects**

Make sure that the installation complies with the standards and rules that apply in your country. Always secure the device with a secondary safety attachment, such as a safety cable or a safety chain.

**NOTICE!****Risk of overheating**

The distance between light output and the illuminated surface must be more than 1.5 m (19.7in).

Provide sufficient ventilation.

The ambient temperature must always be below 40 °C (104 °F).

**NOTICE!****Use of stands**

When mounting the device onto a stand, ensure that the stand is in a safe and stable position and that the weight of the device does not exceed the maximum permissible load capacity of the stand.

**NOTICE!****Possible data transmission errors**

For error-free operation make use of dedicated DMX cables and do not use ordinary microphone cables.

Never connect the DMX input or output to audio devices such as mixers or amplifiers.

## 5 Starting up

Create all connections while the device is off. Use the shortest possible high-quality cables for all connections. Take care when running the cables to prevent tripping hazards.

### Connections in DMX mode

Connect the DMX input of the device to the DMX output of a DMX controller or another DMX device. Connect the output of the first DMX device to the input of the second one, and so on to form a daisy chain. Always ensure that the output of the last DMX device in the daisy chain is terminated with a resistor ( $110\ \Omega$ ,  $\frac{1}{4}\text{ W}$ ).

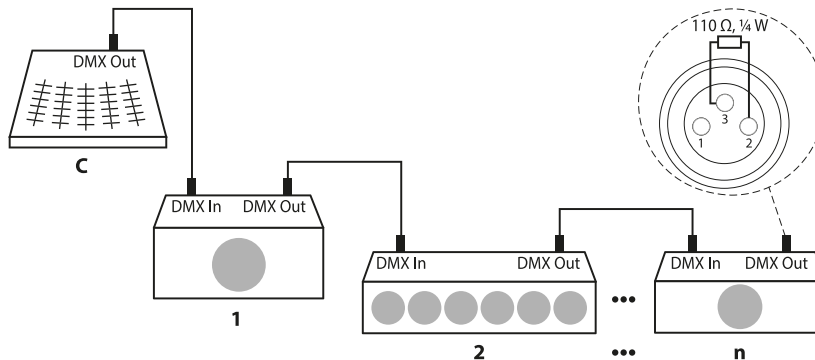



**DMX indicator**

If the unit is in DMX mode and a DMX controller is connected and turned on, a dot on the fourth digit of the display will flash. If the unit is in DMX mode, but without a turned on DMX controller connected, the display will flash.

**Connections in master/slave mode**

When you configure a group of devices in master/slave mode, the first unit will control the other units for an automatic, sound-activated, synchronized show. This function is ideal when you want to start a show immediately. Connect the DMX output of the master device to the DMX input of the first slave device. Then connect the DMX output of the first slave device to the DMX input of the second slave device and so on.



*Please note that this device must not be connected to a dimmer.*

## 6 Connections and operating elements

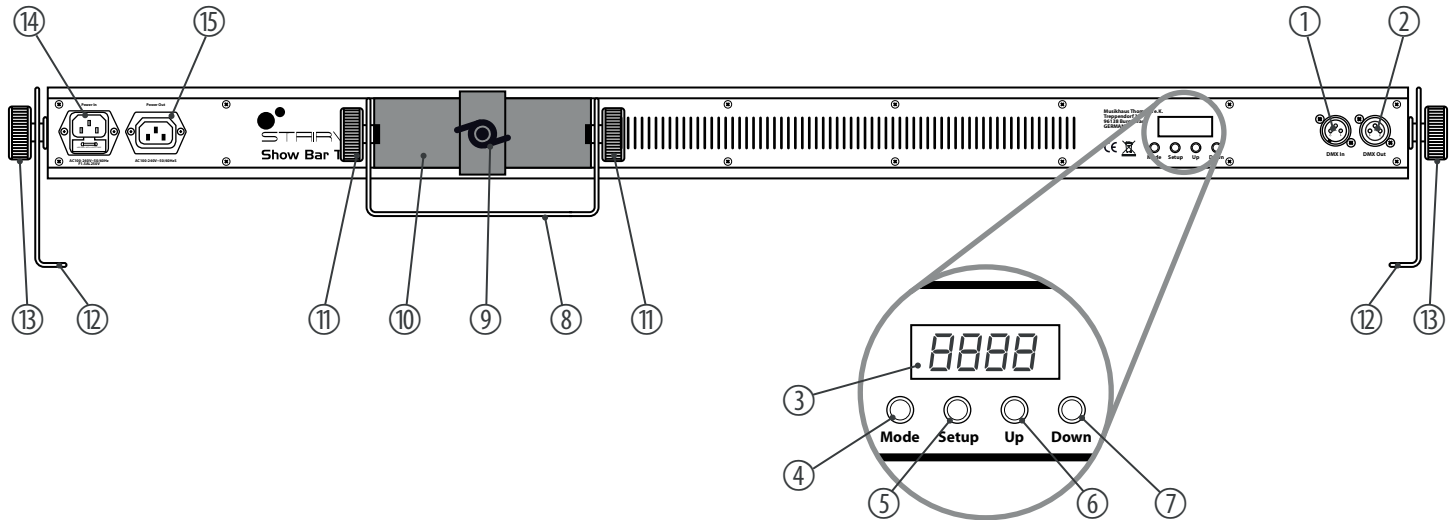

1	<i>[DMX In]</i>   DMX input
2	<i>[DMX Out]</i>   DMX output
3	Display
4	<i>[Mode]</i>   activates the main menu and toggles between menu items.
5	<i>[Setup]</i>   selects an option of the respective operating mode.
6	<i>[Up]</i>   navigates upwards in a menu list. Increases the displayed value by one
7	<i>[Down]</i>   navigates downwards in a menu list. Decreases the displayed value by one.
8	Adjustable and detachable bracket for mounting or transporting the device
9	Locking screw for fixing the carriage
10	Horizontally slidable carriage
11	Locking screws for the adjustable retaining bracket
12	Adjustable and removable mounting brackets and feet
13	Locking screws for the mounting brackets / feet
14	<i>[POWER In]</i>   IEC chassis plug for power supply with fuse holder
15	<i>[POWER Out]</i>   IEC chassis socket for the power supply cable to the next unit

## 7 Operating

### 7.1 Starting the device

Connect the device to the power supply to start operation. After a few seconds, the display indicates that a reset is in progress. The device is then ready for use. The display shows the operating mode that was selected when the unit was last powered off.

### 7.2 Main menu

Press *[Mode]* to activate the main menu and select an operating mode. Use *[Up]* and *[Down]* to change the respectively displayed value. When the display shows the desired value, press *[MODE]*.

If you don't press any button for about 30 seconds, the current setting will be automatically applied and the display turns off. The set values are retained as long as the device is connected to the mains power supply.

### Operating mode 'Preprogrammed automatic show'

A preprogrammed automatic show can only be activated when the unit is operating in stand-alone mode or as master in a master / slave combination. This setting is only relevant if the device is not controlled via DMX.

Press *[Mode]* repeatedly until the display shows 'Prxx'. Now you can select one of the preprogrammed automatic shows. Use *[Up]* and *[Down]* to select a value between 'Pr01' and 'Pr25'.

To adjust the speed of the selected auto show, press *[Setup]* repeatedly until the display indicates 'SPxx'. Use *[Up]* and *[Down]* to select a value between 'SP01' (slow) and 'SPFL' (fast).

To adjust the flash frequency, press *[Setup]* repeatedly until the display shows 'FSxx'. Use *[Up]* and *[Down]* to select a value between 'FS00' (slow) and 'FSFL' (fast).

Wait about 30 seconds until the display turns dark. Then the settings have been applied. To return to the parent menu without making changes, press *[Mode]*.

### **Operating mode 'Automatic'**

Automatic operation can only be activated when the unit is operating in stand alone mode or as master in a master / slave combination. This setting is only relevant if the device is not controlled via DMX.

Press *[Mode]* repeatedly until the display shows 'Auto'. Press *[Setup]* until the display shows 'nxxx'. Now you can select an automatic option. Use *[Up]* and *[Down]* to select a value between 'n001' and 'n100'.

To adjust the speed of the selected auto show, press *[Setup]* repeatedly until the display shows 'SPxx'. Use *[Up]* and *[Down]* to select a value between 'SP01' (slow) and 'SPFL' (fast).

To adjust the flash frequency, press *[Setup]* repeatedly until the display shows 'FSxx'. Use *[Up]* and *[Down]* to select a value between 'FS00' (slow) and 'FSFL' (fast).

Wait about 30 seconds until the display turns dark. Then the settings have been applied. To return to the parent menu without making changes, press *[Mode]*.

**DMX address**

This setting is only relevant when the device is controlled via DMX.

Press *[Mode]* repeatedly until the display shows 'dxxx'.

Now you can set the number of the first DMX channel to be used by the device (DMX address). Use *[Up]* and *[Down]* to select a value between 1 and 512 (display shows 'd001' ... 'd512').

Make sure that this number matches the configuration of your DMX controller. The following table shows the highest possible first DMX address for the various DMX modes.

Mode	Highest possible DMX address
2-channel	511
3-channel	510
5-channel	508
7-channel	506
18-channel	495
27-channel	486
54-channel	459

Wait about 30 seconds until the display turns dark. Then the settings have been applied. To return to the parent menu without making changes, press *[Mode]*.

### DMX mode

This setting is only relevant when the device is controlled via DMX.

Press *[Mode]* repeatedly until the display shows 'dxxx'. Press *[Setup]*. Now use *[UP]* and *[DOWN]* to select one of the following DMX operating modes:

- '2-ch' (two channels)
- '3-ch' (three channels)
- '5-ch' (five channels)
- '7-ch' (seven channels)
- '18ch' (18 channels)
- '27ch' (27 channels)
- '54ch' (54 channels)

Wait about 30 seconds until the display turns dark. Then the settings have been applied. To return to the parent menu without making changes, press *[Mode]*.

### Operating mode 'Slave'

This setting is only relevant if the device is serving as Slave in a Master / Slave configuration and is not controlled via DMX.

Press *[Mode]* until the display shows 'SLAv'.

Wait about 30 seconds until the display turns dark. Then the settings have been applied. To return to the parent menu without making changes, press *[Mode]*.



**Sound control and microphone sensitivity**

A sound controlled automatic show can only be activated when the unit is operating in stand alone mode or as master in a master / slave combination. This setting is only relevant if the device is not controlled via DMX.

Press *[Mode]* until the display shows 'SUxx'. This activates a sound controlled automatic show.

Now you can adjust the sensitivity of the built-in microphone for sound control. Use *[Up]* and *[Down]* to select a value between 0 (low sensitivity) and 31 (high sensitivity), the display shows 'SU00' ... 'SU31'.

Wait about 30 seconds until the display turns dark. Then the settings have been applied. To return to the parent menu without making changes, press *[Mode]*.

### Constant unicoloured pattern

A constant unicoloured pattern can only be activated when the unit is operating in stand alone mode or as master in a master / slave combination. This setting is only relevant if the device is not controlled via DMX.

Press *[Mode]* repeatedly until the display shows 'CLor'.

Press *[Setup]*. Now use *[Up]* and *[Down]* to select one of the following options:

Display	Meaning
'r.000' ... 'r.255'	Red
'G.000' ... 'G.255'	Green
'b.000' ... 'b.255'	Blue

To adjust the flash frequency, press *[Setup]* repeatedly until the display shows 'FSxx'. Use *[Up]* and *[Down]* to select a value between 'FS00' (slow) and 'FSFL' (fast).

Wait about 30 seconds until the display turns dark. Then the settings have been applied. To return to the parent menu without making changes, press *[Mode]*.

### 7.3 Menu overview

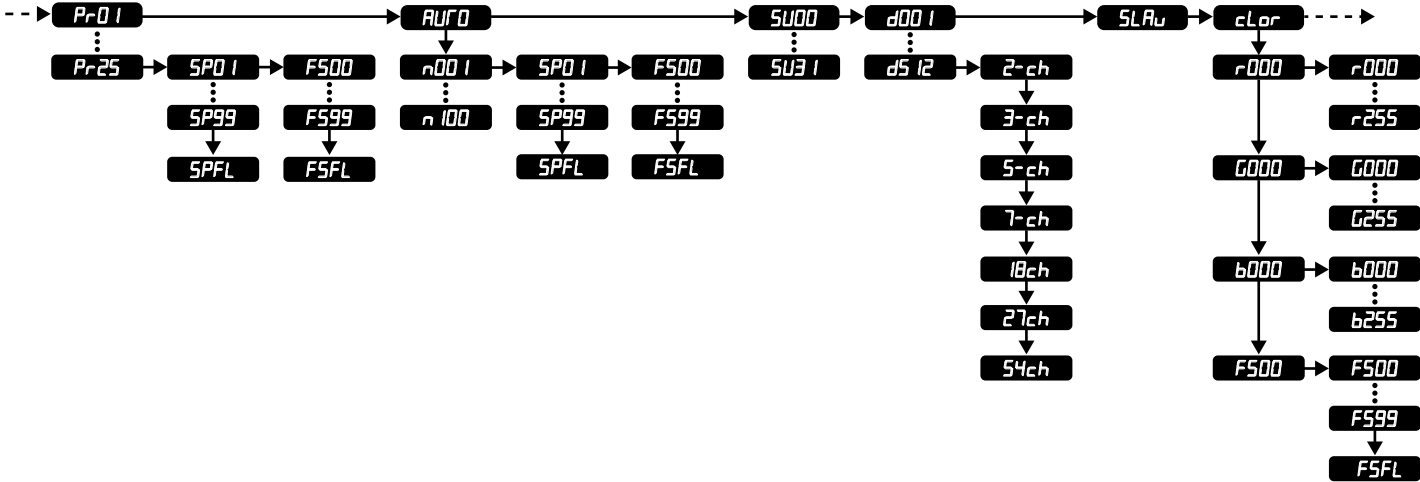

## 7.4 Functions in 2-channel DMX mode

Channel	Value	Function
1	Operating mode	
	0	Dark
	1...7	Red
	8...15	Red + Green
	16...23	Green
	24...31	Green + Blue
	32...39	Blue
	40...47	Red + blue
	48...55	Red + Green + Blue
	56...63	Preprogrammed automatic show no. 2
	64...71	Preprogrammed automatic show no. 3
	72...79	Preprogrammed automatic show no. 4
	⋮	⋮
	240...247	Preprogrammed automatic show no. 25

Channel	Value	Function
	248...255	Sound-controlled show
2	0...255	Sound control sensitivity (from insensitive to highly sensitive)

## 7.5 Functions in 3-channel DMX mode

Channel	Value	Function
1	0 ... 255	Intensity Red (0 % to 100 %)
2	0 ... 255	Intensity Green (0 % to 100 %)
3	0 ... 255	Intensity Blue (0 % to 100 %)

## 7.6 Functions in 5-channel DMX mode

Channel	Value	Function
1	0 ... 255	Intensity Red (0 % to 100 %)
2	0 ... 255	Intensity Green (0 % to 100 %)

Channel	Value	Function
3	0 ... 255	Intensity Blue (0 % to 100 %)
4	0 ... 255	Dimmer (0 % to 100 %)
5	0 ... 255	Strobe effect, increasing speed

## 7.7 Functions in 7-channel DMX mode

Channel	Value	Function
1	0...255	Intensity Red (0 % to 100 %), if channel 5 = 0
2	0...255	Intensity Green (0 % to 100 %), if channel 5 = 0
3	0...255	Intensity Blue (0 % to 100 %), if channel 5 = 0
4	0...255	Dimmer (0 % to 100 %)
5	0...255	Strobe effect, increasing speed
6	Operating mode	
	0	Colour mixing with channels 1, 2 and 3
	1...7	Red

Channel	Value	Function
	8...15	Red + Green
	16...23	Green
	24...31	Green + Blue
	32...39	Blue
	40...47	Red + blue
	48...55	Red + Green + Blue
	56...63	Preprogrammed automatic show no. 2
	64...71	Preprogrammed automatic show no. 3
	72...79	Preprogrammed automatic show no. 4
	⋮	⋮
	240...247	Preprogrammed automatic show no. 25
	248...255	Sound-controlled show
7	0...255	Progress speed, if channel 6 = 1...247, slow to fast
		Sensitivity of the sound control, if channel 6 = 248...255, from low to high sensitivity

## 7.8 Functions in 18-channel DMX mode

In this mode, the LEDs are divided into six groups of three LEDs each. Each channel controls a primary colour of a group.

Channel	Value	LEDs	Function
1	0...255	1...3	Intensity red (0 % to 100 %)
2	0...255		Intensity green (0 % to 100 %)
3	0...255		Intensity blue (0 % to 100 %)
4	0...255	4...6	Intensity red (0 % to 100 %)
5	0...255		Intensity green (0 % to 100 %)
6	0...255		Intensity blue (0 % to 100 %)
7	0...255	7...9	Intensity red (0 % to 100 %)
8	0...255		Intensity green (0 % to 100 %)
9	0...255		Intensity blue (0 % to 100 %)
10	0...255	10...12	Intensity red (0 % to 100 %)
11	0...255		Intensity green (0 % to 100 %)
12	0...255		Intensity blue (0 % to 100 %)



Channel	Value	LEDs	Function
13	0...255	13...15	Intensity red (0 % to 100 %)
14	0...255		Intensity green (0 % to 100 %)
15	0...255		Intensity blue (0 % to 100 %)
16	0...255	16...18	Intensity red (0 % to 100 %)
17	0...255		Intensity green (0 % to 100 %)
18	0...255		Intensity blue (0 % to 100 %)

## 7.9 Functions in 27-channel DMX mode

In this mode, the LEDs are divided into nine groups of two LEDs each. Each channel controls a primary colour of a group.

Channel	Value	LEDs	Function
1	0...255	1...2	Intensity red (0 % to 100 %)
2	0...255		Intensity green (0 % to 100 %)
3	0...255		Intensity blue (0 % to 100 %)

Channel	Value	LEDs	Function
4	0...255	3...4	Intensity red (0 % to 100 %)
5	0...255		Intensity green (0 % to 100 %)
6	0...255		Intensity blue (0 % to 100 %)
7	0...255	5...6	Intensity red (0 % to 100 %)
8	0...255		Intensity green (0 % to 100 %)
9	0...255		Intensity blue (0 % to 100 %)
:		:	
22	0...255	15...16	Intensity red (0 % to 100 %)
23	0...255		Intensity green (0 % to 100 %)
24	0...255		Intensity blue (0 % to 100 %)
25	0...255	17...18	Intensity red (0 % to 100 %)
26	0...255		Intensity green (0 % to 100 %)
27	0...255		Intensity blue (0 % to 100 %)

## 7.10 Functions in 54-channel DMX mode

In this mode, you can control each LED individually. Each channel controls a primary colour of an LED.

Channel	Value	LEDs	Function
1	0...255	1	Intensity red (0 % to 100 %)
2	0...255		Intensity green (0 % to 100 %)
3	0...255		Intensity blue (0 % to 100 %)
4	0...255	2	Intensity red (0 % to 100 %)
5	0...255		Intensity green (0 % to 100 %)
6	0...255		Intensity blue (0 % to 100 %)
7	0...255	3	Intensity red (0 % to 100 %)
8	0...255		Intensity green (0 % to 100 %)
9	0...255		Intensity blue (0 % to 100 %)
:		:	
49	0...255	17	Intensity red (0 % to 100 %)
50	0...255		Intensity green (0 % to 100 %)

Channel	Value	LEDs	Function
51	0...255		Intensity blue (0 % to 100 %)
52	0...255	18	Intensity red (0 % to 100 %)
53	0...255		Intensity green (0 % to 100 %)
54	0...255		Intensity blue (0 % to 100 %)

## 8 Technical specifications

Light source	18 × RGB LED, 3 W	
Optical properties	Beam angle	approx. 23°
Control	DMX	
Number of DMX channels	2, 3, 5, 7, 18, 27, 54	
Input connections	Power supply	IEC chassis plug C14
	DMX control	XLR chassis socket, 3-pin
Output connections	Power supply	IEC chassis socket C13
	DMX control	XLR chassis socket, 3-pin
Power consumption	84 W	
Supply voltage	100 - 240 V ~ 50/60 Hz	
Fuse	5 mm × 20 mm, 3 A, 250 V, slow-blow	
Degree of protection	IP20	
Mounting options	Wall mounting, ceiling mounting, floor mounting	
Dimensions (W × H × D)	1050 mm (without stand) × 70 mm × 70 mm (without bracket)	
	1126 mm (incl. stand) × 70 mm × 170 mm (incl. bracket)	

## Technical specifications

---

Weight	4.96 kg	
Ambient conditions	Temperature range	0 °C...40 °C
	Relative humidity	20 %...80 % (non-condensing)

### Further information

Suitable for outdoor use	no
Colour mixture	RGB
LED type	x-in-1
fanless	yes
Wireless DMX	no
Housing colour	black
Separately controllable LEDs	yes

# 9 Plug and connection assignments

## Introduction

This chapter will help you select the right cables and plugs to connect your valuable equipment so that a perfect light experience is guaranteed.

Please take our tips, because especially in 'Sound & Light' caution is indicated: Even if a plug fits into a socket, the result of an incorrect connection may be a destroyed DMX controller, a short circuit or 'just' a not working light show!

## DMX connections

The unit offers a 3-pin XLR socket for DMX output and a 3-pin XLR plug for DMX input. Please refer to the drawing and table below for the pin assignment of a suitable XLR plug.



Pin	Configuration
1	Ground, shielding
2	Signal inverted (DMX-, 'cold signal')
3	Signal (DMX+, 'hot signal')

## 10 Troubleshooting



### **NOTICE!**

#### **Possible data transmission errors**

For error-free operation make use of dedicated DMX cables and do not use ordinary microphone cables.

Never connect the DMX input or output to audio devices such as mixers or amplifiers.

In the following we list a few common problems that may occur during operation. We give you some suggestions for easy troubleshooting:



Symptom	Remedy
The unit does not work, no light, the display is dark	Check the mains connection and the main fuse.
Apparently no function despite proper power supply	Check if the unit is in DMX mode or in 'slave' mode. If so, check the device into a different mode.
No response to the DMX controller	<ol style="list-style-type: none"> <li data-bbox="887 390 1520 516">1. If the unit is in DMX mode and the display flashes, no DMX signal is received. Check that the DMX controller is switched on. Check the DMX connectors and cables for proper connection.</li> <li data-bbox="887 516 1520 714">2. If the unit is in DMX mode and a DMX controller is connected and turned on, a dot on the fourth digit of the display will flash. If it doesn't, no valid DMX signal is received. Check that the DMX controller is switched on. Check the DMX connectors and cables for proper connection.</li> <li data-bbox="887 714 1520 826">3. If the display dot is flashing but there is still no response, check the address settings and the DMX polarity.</li> <li data-bbox="887 826 1520 876">4. Try using another DMX controller.</li> <li data-bbox="887 876 1520 972">5. Check to see if the DMX cables run near or alongside to high voltage cables that may cause damage or interference to DMX interface circuits.</li> </ol>

If the procedures recommended above do not succeed, please contact our Service Center. You can find the contact information at [www.thomann.de](http://www.thomann.de).

## 11 Cleaning

### Optical lenses

Clean the optical lenses, that are accessible from the outside, regularly in order to optimize the light output. The frequency of cleaning depends on the operating environment: wet, smoky or particularly dirty surroundings can cause more accumulation of dirt on the optics of the device.

- Clean with a soft cloth using our lamp and lens cleaner (item no. 280122).
- Always dry the parts carefully.

### Fan grids

The fan grids of the device must be cleaned of any contamination, such as dust, etc. on a regular basis. Before cleaning, switch off the device and disconnect mains-operated devices from the mains. Only use pH-neutral, solvent-free and non-abrasive cleaning agents. Clean the unit with a slightly damp lint-free cloth.

## 12 Protecting the environment

### Disposal of the packaging material



For the transport and protective packaging, environmentally friendly materials have been chosen that can be supplied to normal recycling.

Ensure that plastic bags, packaging, etc. are properly disposed of.

Do not just dispose of these materials with your normal household waste, but make sure that they are collected for recycling. Please follow the notes and markings on the packaging.

### Disposal of your old device



This product is subject to the European Waste Electrical and Electronic Equipment Directive (WEEE) in its currently valid version. Do not dispose with your normal household waste.

Dispose of this device through an approved waste disposal firm or through your local waste facility. When discarding the device, comply with the rules and regulations that apply in your country. If in doubt, consult your local waste disposal facility.







