



DMX DC-1224

DMX controller

Musikhaus Thomann
Thomann GmbH
Hans-Thomann-Straße 1
96138 Burgebrach
Germany
Telephone: +49 (0) 9546 9223-0
E-mail: info@thomann.de
Internet: www.thomann.de

20.04.2018, ID: 346647

Table of contents

1	General notes	5
	1.1 Further information.....	5
	1.2 Notational conventions.....	5
	1.3 Symbols and signal words.....	6
2	Safety instructions	7
3	Features	9
4	Installation	10
5	Starting up	11
6	Connections and controls	12
7	Operating	16
	7.1 Starting programming.....	16
	7.2 Editing.....	18
	7.3 Operation.....	21
8	MIDI and DMX channel settings	23
	8.1 MIDI.....	23
	8.2 DMX.....	25
9	Quick Start Guide for the main functions	27
	9.1 Reversing scene direction.....	27
	9.2 Setting Fade time.....	27
	9.3 Using TAP SYNC.....	27
	9.4 Using MASTER fader.....	28
	9.5 Selecting 'Single' mode.....	28
	9.6 'Mix' mode.....	28
	9.7 Dimmer Display.....	28
	9.8 BLIND and HOME.....	29
	9.9 PARK.....	29
	9.10 ADD/KILL.....	29
	9.11 Double Preset.....	29
10	Technical specifications	31
11	Plug and connection assignments	32
12	Protecting the environment	33



1 General notes

This manual contains important instructions for the safe operation of the unit. Read and follow the safety instructions and all other instructions. Keep the manual for future reference. Make sure that it is available to all those using the device. If you sell the unit please make sure that the buyer also receives this manual.

Our products are subject to a process of continuous development. Thus, they are subject to change.

1.1 Further information

On our website (www.thomann.de) you will find lots of further information and details on the following points:

Download	This manual is also available as PDF file for you to download.
Keyword search	Use the search function in the electronic version to find the topics of interest for you quickly.
Online guides	Our online guides provide detailed information on technical basics and terms.
Personal consultation	For personal consultation please contact our technical hotline.
Service	If you have any problems with the device the customer service will gladly assist you.

1.2 Notational conventions

This manual uses the following notational conventions:

Letterings

The letterings for connectors and controls are marked by square brackets and italics.

Examples: *[VOLUME]* control, *[Mono]* button.

Displays

Texts and values displayed on the device are marked by quotation marks and italics.

Examples: *'24ch'*, *'OFF'*.

Instructions

The individual steps of an instruction are numbered consecutively. The result of a step is indented and highlighted by an arrow.

Example:

1. ➤ Switch on the device.
2. ➤ Press *[Auto]*.
⇒ Automatic operation is started.
3. ➤ Switch off the device.

1.3 Symbols and signal words

In this section you will find an overview of the meaning of symbols and signal words that are used in this manual.

Signal word	Meaning
DANGER!	This combination of symbol and signal word indicates an immediate dangerous situation that will result in death or serious injury if it is not avoided.
WARNING!	This combination of symbol and signal word indicates a possible dangerous situation that can result in death or serious injury if it is not avoided.
NOTICE!	This combination of symbol and signal word indicates a possible dangerous situation that can result in material and environmental damage if it is not avoided.
Warning signs	Type of danger
	Warning – danger zone.

2 Safety instructions

Intended use

This device is used to control spotlights, dimmers, lighting effects equipment, Moving Heads or other DMX-controlled devices. The device is designed for professional use and is not suitable for use in households. Use the device only as described in this user manual. Any other use or use under other operating conditions is considered to be improper and may result in personal injury or property damage. No liability will be assumed for damages resulting from improper use.

This device may be used only by persons with sufficient physical, sensorial, and intellectual abilities and having corresponding knowledge and experience. Other persons may use this device only if they are supervised or instructed by a person who is responsible for their safety.

Safety



DANGER!

Danger for children

Ensure that plastic bags, packaging, etc. are disposed of properly and are not within reach of babies and young children. Choking hazard!

Ensure that children do not detach any small parts (e.g. knobs or the like) from the unit. They could swallow the pieces and choke!

Never let children unattended use electrical devices.



NOTICE!

External power supply

The device is powered by an external power supply. Before connecting the external power supply, ensure that the input voltage (AC outlet) matches the voltage rating of the device and that the AC outlet is protected by a residual current circuit breaker. Failure to do so could result in damage to the device and possibly the user.

Unplug the external power supply before electrical storms occur and when the device is unused for long periods of time to reduce the risk of electric shock or fire.



NOTICE!

Risk of fire

Do not block areas of ventilation. Do not install the device near any direct heat source. Keep the device away from naked flames.



NOTICE!

Operating conditions

This device has been designed for indoor use only. To prevent damage, never expose the device to any liquid or moisture. Avoid direct sunlight, heavy dirt, and strong vibrations.

**NOTICE!****Possible staining**

The plasticiser contained in the rubber feet of this product may possibly react with the coating of your parquet, linoleum, laminate or PVC floor and after some time cause permanent dark stains.

In case of doubt, do not put the rubber feet directly on the floor, but use felt-pad floor protectors or a carpet.

3 Features

Special features of the device:

- 24 control channels, freely assignable to 512 DMX channels
- Connection for a fog machine
- 4600 scenes
- 4 banks with 48 freely programmable, directly accessible programmes
- Twelve programmable chases
- 24 faders for manual control
- Assigned or reversed DMX channel preview
- Sound-to-Light
- 3 function layers
- Blind home function
- Speed fade control
- Blackout master
- Stand-alone mode
- Manual overriding of scenes in chases
- MIDI control for banks, chases and blackout
- LCD

4 Installation

Wiring diagram for fog machines

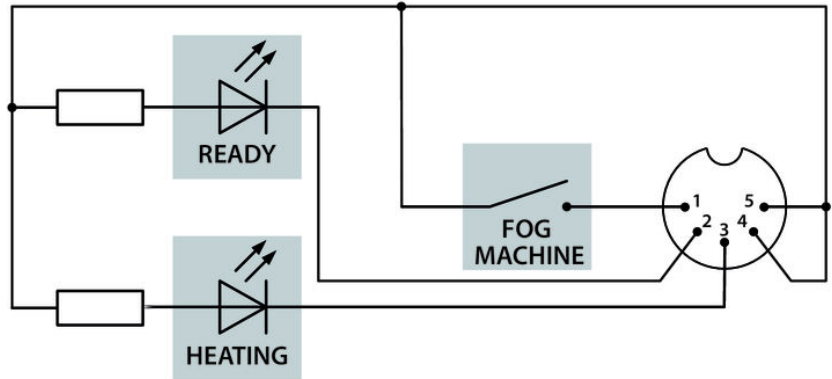

Rack mounting

If the unit is to be mounted in a 19" rack, remove the plastic panel. There to loosen the screws that hold the panel.

5 Starting up

Unpack and carefully check that there is no transportation damage before using the unit. Keep the equipment packaging. To fully protect the device against vibration, dust and moisture during transportation or storage use the original packaging or your own packaging material suitable for transport or storage, respectively.

Create all connections while the device is off. Use the shortest possible high-quality cables for all connections. Take care when running the cables to prevent tripping hazards.



NOTICE!

Possible data transmission errors

For error-free operation make use of dedicated DMX cables and do not use ordinary microphone cables.

Never connect the DMX input or output to audio devices such as mixers or amplifiers.

Connections in DMX mode

Connect the DMX output of the device (C) to the DMX input of the first DMX device (1). Connect the output of the first DMX device to the input of the second one, and so on to form a daisy chain. Always ensure that the output of the last DMX device in the daisy chain is terminated with a resistor ($110\ \Omega$, $\frac{1}{4}\ \text{W}$).

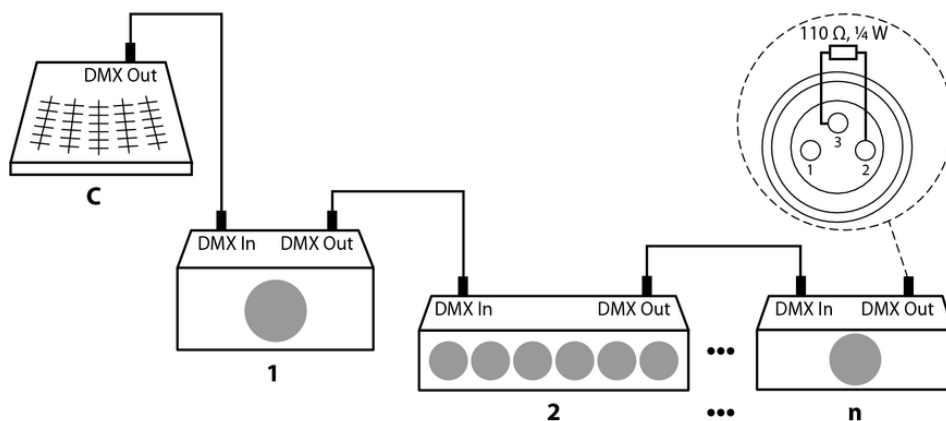

Connecting the power adapter

Connect the included 9V power supply unit to the power supply input of the unit and then plug the power cord plug into the wall outlet.

Turning the unit on

When all cable connections are made, turn on the device with the main switch on the rear panel. The device is immediately operational.

6 Connections and controls

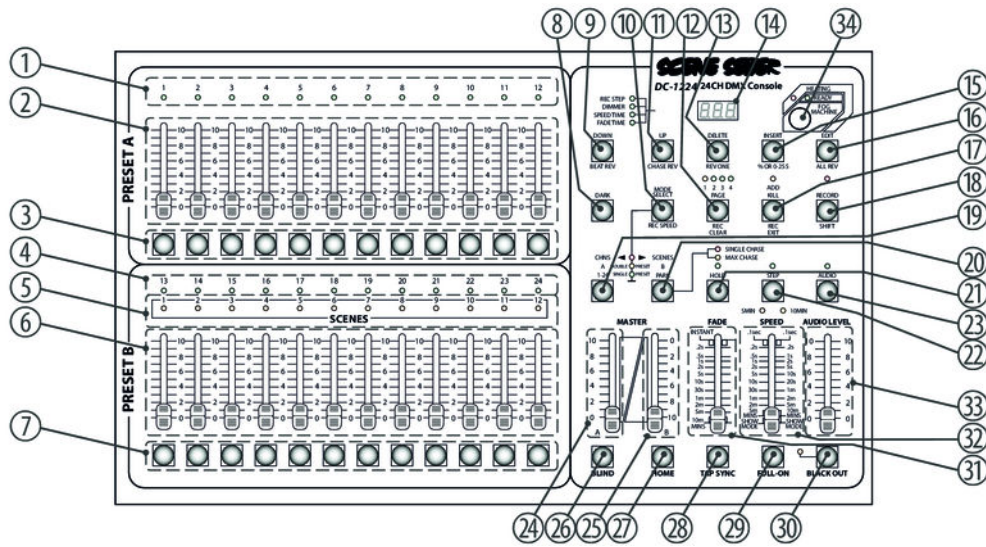

- | | |
|---|-------------------------------------------------------------------------------------------------------------------------------------------------------------|
| 1 | [PRESET A 1-12]
Indicates the current intensity of the corresponding channels. |
| 2 | [Channel faders 1-12]
These faders can be used to adjust / programme the intensity of channels 1-12. |
| 3 | [FLASH 1-12]
When this button is pressed, the intensity of the respective channel 1-12 is set to 100 %. |
| 4 | [PRESET B 13-24]
Indicates the current intensity of the corresponding channels. |
| 5 | [SCENES 1-12]
These LEDs light up when the corresponding scene is activated. |
| 6 | Channel faders [13-24] / Scene faders [1-12]
These faders can be used to adjust / programme the intensity of channels 13-24 . |
| 7 | [FLASH 13-24]
When this button is pressed, the intensity of the respective channel 13-24 is set to 100 %. |
| 8 | [DARK]
As long as this button is held, all DMX values at the output are set to [000]. |
| 9 | [DOWN/BEAT REV]
Use [Down] to change a scene in Edit mode.
Use [Beat Rev] to change the direction of the chase during a programme with constant beat. |

10	<p><i>[MODE SELECT/REC SPEED]</i></p> <p>Use <i>[Mode Select]</i> to select between these three modes:</p> <ul style="list-style-type: none"> ■ CHNS< >SCENES ■ A DOUBLE PRESET B ■ 1-12 SINGLE PRESET <p>Use <i>[Rec Speed]</i> to adjust the speed of all programmes in 'Mix' mode.</p>
11	<p><i>[UP/CHASE REV]</i></p> <p>Use <i>[DOWN]</i> to change a scene in Edit mode.</p> <p>Use <i>[CHASE REV]</i> to change the direction of all chases.</p>
12	<p><i>[PAGE]</i></p> <p>Switches between the four PAGES (banks).</p>
13	<p><i>[DELETE/REV ONE]</i></p> <p><i>[DELETE]</i> deletes every step of a scene.</p> <p><i>[REV ONE]</i> changes the direction of a chase.</p>
14	<p><i>[Display]</i></p> <p>This display shows the current activity or programme status.</p>
15	<p><i>[INSERT/% OR 255]</i></p> <p>Use <i>[INSERT]</i> to add steps to a scene.</p> <p>Use <i>[% OR 255]</i> to choose whether to see the value as a percentage value or as a value between 0-255.</p>
16	<p><i>[EDIT/ALL REV]</i></p> <p><i>[EDIT]</i> is used to start the Edit mode.</p> <p>Use <i>[ALL REV]</i> to change the direction of all programmes.</p>
17	<p><i>[ADD OR KILL/REC EXIT]</i></p> <p>In <i>[ADD]</i> , several Scenes or Flash buttons are active.</p> <p>In <i>[KILL]</i> , pressing a flash button disables any other scene or programme.</p> <p>Use <i>[REC EXIT]</i> to quit the Edit mode.</p>
18	<p><i>[RECORD/SHIFT]</i></p> <p><i>[RECORD]</i> is used to start the Record mode or to programme a Stop.</p> <p><i>[SHIFT]</i> is only used in conjunction with other buttons.</p>
19	<p><i>[MASTER A]</i></p> <p>Sets the intensity of Master A to 100 % as long as the button is pressed.</p>
20	<p><i>[PARK]</i></p> <p>In CHNS< >SCENES mode, you can switch between single-chase or mix-chase mode.</p> <p>In Single-chase mode, the activated programmes run one after the other. In Mix-chase mode, the activated programmes run simultaneously.</p>

21	<i>[HOLD]</i> Freezes all current DMX values at the output.
22	<i>[STEP]</i> This button is used to advance to the next step when <i>[SPEED]</i> is at the lowest setting or when 'Edit' mode is activated.
23	<i>[AUDIO]</i> Activates the 'Audio' mode.
24	<i>[MASTER A]</i> Master fader for channels 1-12.
25	<i>[MASTER B]</i> Master fader for channels 13-24.
26	<i>[BLIND]</i> This key is used to temporarily remove individual channels from a running programme.
27	<i>[HOME]</i> Use this key to end the Blind mode.
28	<i>[TAP SYNC]</i> If the device is in 'Run' mode, you can manually set the operating speed with <i>[TAP SYNC]</i> . Hereto press the button twice to set the speed.
29	<i>[FULL ON]</i> Sets all DMX values to [255].
30	<i>[BLACK OUT]</i> Sets all DMX values at the output to [000].
31	<i>[FADE]</i> Use <i>[FADE]</i> to set the fade time.
32	<i>[SPEED]</i> Use <i>[SPEED]</i> to set the Chase speed.
33	<i>[AUDIO LEVEL]</i> Use <i>[AUDIO LEVEL]</i> to set the audio sensitivity.
34	<i>[FOG MACHINE]</i> Operating and display elements for a fog machine.

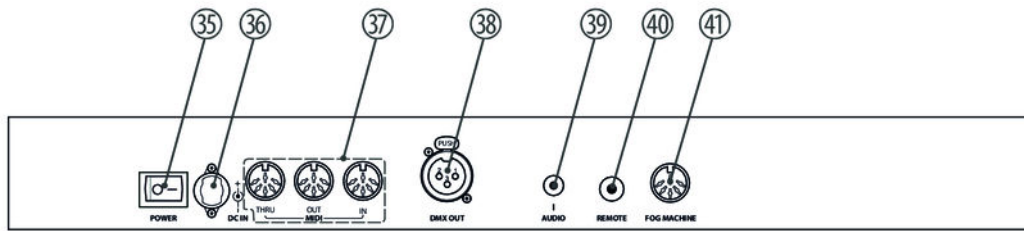

35	<i>[POWER]</i> Turns the device on and off.
36	<i>[DC IN]</i> Power supply port.
37	<i>[MIDI THRU/OUT/IN]</i> 'MIDI' ports to connect a sequencer or MIDI device.
38	<i>[DMX OUT]</i> This terminal sends DMX signals to DMX capable devices. Use a cable with 3-pin XLR connector to connect the devices.
39	<i>[AUDIO]</i> At this input, an audio signal with a level of 100 mV to 1 V can be connected.
40	<i>[REMOTE]</i> 'Black out' and 'Full on' can also be activated via a remote control. Please use a 1/4" jack plug (stereo) for connection.
41	<i>[FOG MACHINE]</i> A fog machine can be connected to this input.

7 Operating

7.1 Starting programming

7.1.1 Enabling programming

1. ➤ Keep [RECORD] pressed.
2. ➤ While holding down [RECORD], press the Flash buttons 1, 6, 6 and 8 in sequence.



When you turn on the unit for the first time, the record code is 1, 6, 6 and 8. You can change the code to protect your programmes.

3. ➤ Release [RECORD].
⇒ The RECORD LED lights up.
Now you can start programming.

7.1.2 Protecting programmes

To protect your programmes, you can change the 'Record' code. To change the Record code, proceed as follows:

1. ➤ Activate the programming (↪ Chapter 7.1.1 'Enabling programming' on page 16).
2. ➤ Keep [RECORD] and [EDIT] pressed simultaneously.

3. ➤



The record code consists of a combination of four "Flash" buttons, this number may not be exceeded or fallen below.

While holding down [RECORD] and [EDIT], enter the new code using the flash buttons.

4. ➤ Release [RECORD] and [EDIT].
⇒ The display shows 'Cod'
5. ➤ Keep [RECORD] and [EDIT] pressed simultaneously.

6. ▶ Re-enter the new 'Record' code.
 - ⇒ All Channel and Scene LEDs flash three times.
 - The RECORD code is now changed.



If you re-enter something other than the first time, the LEDs will not light up. This means that changing the 'Record' code has failed.



WARNING!

Always remember to exit 'Record' mode if you do not want to continue programming. If you forget this, you lose control of the device.

7. ▶ To quite the Record mode, press [REC EXIT] while holding down [RECORD] .
8. ▶ Release both buttons.
 - ⇒ The LED of the [RECORD] button turns off. You have left the 'Record' mode.

To cancel the process of changing the record code:

- ▶ Press [RECORD] and [EXIT] simultaneously.
 - ⇒ The change process is cancelled.

7.1.3 Programming a scene

1. ▶ Activate the programming ↪ Chapter 7.1.1 'Enabling programming' on page 16.



Make sure the faders [Master A&B] are both set to their maximum. ([MASTER A] is set to maximum when it is at the top. [MASTER B] is set to maximum when it is at the bottom).

2. ▶ To select the mode '1-24 Single', press [MODE SELECT]. This gives you control over all 24 channels.
3. ▶ Create the desired scene using the channel faders 1-24. At 0 % or DMX 0, the faders should be in position 0, at 100 % or DMX 255, the faders should be in position 10.
4. ▶ To save the desired scene as a step, press [RECORD].
5. ▶ Repeat steps 3 and 4 until all desired steps have been stored.



You can store up to 1000 steps in memory.

6. ▶ Press [PAGE] to select a page (1-4) where you save your scenes.

7. ➤ Keep *[RECORD]* pressed and additionally press one of the *[FLASH]* buttons between 13 and 24

⇒ All record LEDs flash once.

The program is saved.

8. ➤ To exit programming mode, press *[Exit]* and *[RECORD]* simultaneously.

Example programme

Programming a chase with 16 steps with channels 1-16 and storing a sequence to *[Flash 15]* on Page 1.

1. ➤ Activate the programming (↪ Chapter 7.1.1 'Enabling programming' on page 16).



Make sure the faders [Master A&B] are both set to their maximum. [MASTER A] is set to maximum when it is at the top. [MASTER B] is set to maximum when it is at the bottom.

2. ➤ To select the mode '1-24 Single', press *[MODE SELECT]*. This gives you control over all 24 channels.

3. ➤ Slide channel fader 1 to position 10.

⇒ The LED lights up fully.

4. ➤ To save the desired scene as a step, press *[RECORD]*.

5. ➤ Repeat steps 4 and 5 until all channels 1-16 have been programmed.

6. ➤ Press *[PAGE]* until the LED at *[PAGE 1]* is lit.

7. ➤ Press *[FLASH 15]* while holding down *[RECORD]*.

⇒ All record LEDs flash once.

The program is saved.

7.2 Editing

7.2.1 Programme editing

1. ➤ Activate the programming (↪ Chapter 7.1.1 'Enabling programming' on page 16).

2. ➤ Use *[PAGE]* to select the page where the programme to be edited is stored.

3. ➤ Press *[MODE SELECT]* to select *[CHNS< >SCENES]*.

4. ➤ Keep *[EDIT]* pressed.

5. ➤ Press the respective *[FLASH]* button.

6. ➤ Release *[EDIT]*.

⇒ The LED of the corresponding scene lights up, indicating that the device is in 'Edit' mode.

7.2.2 Deleting programme

1. ▶ Activate the programming (↪ Chapter 7.1.1 'Enabling programming' on page 16).
2. ▶ Use [PAGE] to select the page where the programme to be edited is stored.
3. ▶ Keep [RECORD] and [EDIT] pressed.
4. ▶ Press the respective [FLASH] button.
5. ▶ Release both buttons.
 - ⇒ All LEDs light up.
 - The programme is deleted.

7.2.3 Deleting all programmes

1. ▶ Activate the programming (↪ Chapter 7.1.1 'Enabling programming' on page 16).
2. ▶ Keep [RECORD] pressed.
3. ▶ Press [FLASH 1], [FLASH 4], [FLASH 2] and [FLASH 3] successively.
 - ⇒ All LEDs light up.
 - All programmes are deleted.

7.2.4 Deleting scenes

1. ▶ Activate the programming ↪ Chapter 7.1.1 'Enabling programming' on page 16.
2. ▶ Record one or multiple scenes.
3. ▶ If you are not satisfied with one or more scenes, press [REC CLEAR] while keeping [RECORD] pressed.
 - ⇒ All LEDs light up.
 - All scenes in the memory are deleted.

7.2.5 Deleting a single or multiple steps

1. ▶ Activate the programming (↪ Chapter 7.1.1 'Enabling programming' on page 16).
2. ▶ Keep [EDIT] pressed and then simultaneously press the respective [FLASH] button.
3. ▶ Press [STEP] until you have reached the step you want to delete.

4. ➤ Press *[DELETE]*.
 - ⇒ All LEDs light up.
 - The step is deleted.
5. ➤ Repeat steps 2 and 3 to delete all unwanted steps.
6. ➤ Exit the mode. To do so, press *[REC EXIT]* while keeping *[RECORD]* pressed.
 - ⇒ The LED of the scene turns off.
 - You have left the Edit mode.

Example for deleting a step

Deleting the third step in the programme on *[FLASH] 15* on page 2.

1. ➤ Activate the programming (↪ *Chapter 7.1.1 'Enabling programming' on page 16*).
2. ➤ To select *[CHNS</>SCENES]*, press *[MODE SELECT]*.
3. ➤ Press *[FLASH]* while keeping *[EDIT]* pressed.
 - ⇒ The LED of the corresponding scene lights up.
4. ➤ To get to the third step, press *[STEP]*.
5. ➤ To delete this step, press *[DELETE]*.
6. ➤ Exit the mode. To do so, press *[REC EXIT]* while keeping *[RECORD]* pressed.
 - ⇒ The LED of the scene turns off.
 - You have left the Edit mode.

7.2.6 Adding one or multiple steps

1. ➤ Programme one or more steps you want to add (↪ *Chapter 7.1.3 'Programming a scene' on page 17*).
2. ➤ Make sure you are in *[CHNS</>SCENES]* mode and activate the *[EDIT]* mode.
3. ➤ Press *[STEP]* press until you reach the step before which you want to insert a step.
4. ➤ Press *[INSERT]* to add the step.
 - ⇒ All LEDs light up.
 - The step is added.
5. ➤ Exit the Edit mode. To do so, press *[REC EXIT]* while keeping *[RECORD]* pressed.

7.2.7 Changing one or multiple steps

1. ➤ Activate the Edit mode.
2. ➤ To get to the step you want to change, press *[STEP]*.

3. ➤ Press and hold [UP] if you want to increase the intensity. Press and hold [DOWN] if you want to decrease the intensity.
4. ➤ Press the [FLASH] button of the corresponding DMX channel of the scene to be changed. While doing this, press and hold [UP] or [DOWN] pressed.
5. ➤ Press the respective [FLASH] until you are satisfied with your new scene.
6. ➤ Repeat steps 2, 3, 4 and 5 until all steps have been edited.
7. ➤ Exit the Edit mode. To do so, press [REC EXIT] while keeping [RECORD] pressed.

7.3 Operation

7.3.1 Starting a programme

1. ➤ Press [MODE SELECT] to select [CHNS⟨⟩SCENES] .
2. ➤ To call up the page where your desired programme is stored, press [PAGE].
3. ➤ Slide [MASTER B] to position 10.
4. ➤ To initiate the programme, slide the corresponding channel fader (13-24) to position 10.



The 'fade time' of the programme depends on the set 'fade time' on [FADE]. You can also press and hold [FLASH] to initiate the programme.

5. ➤ Use the channel fader to set the intensity of the corresponding programme.

7.3.2 Sound control

1. ➤ Use the built-in microphone or connect an external audio source via an RCA plug.
2. ➤ Select the desired programme ↪ Chapter 7.3.1 'Starting a programme' on page 21.
3. ➤ Press [AUDIO].
 - ⇒ The LED lights up.
 - Audio mode is activated.
4. ➤ Use [AUDIO LEVEL] to adjust the sensitivity.
5. ➤ To exit Audio mode, press [AUDIO] again.
 - ⇒ The LED turns off.
 - 'Audio' mode is disabled.

7.3.3 Setting the programme speed with fader

1. ▶ Make sure that the Audio mode is disabled.
2. ▶ Select the desired programme (↪ Chapter 7.3.1 'Starting a programme' on page 21).
3. ▶ Use [FADE] to set the desired fade time.
4. ▶ Use [SPEED] to set the desired speed.

7.3.4 Setting a standard beat

'Audio' mode is disabled

1. ▶ To select [CHNS< >SCENES], press [MODE SELECT].
2. ▶ Select the desired programme (↪ Chapter 7.3.1 'Starting a programme' on page 21).
3. ▶ You can adjust the speed by pressing [TAP SYNC] twice.

7.3.5 Changing the speed mode between 5 and 10 minutes

1. ▶ Activate the programming (↪ Chapter 7.1.1 'Enabling programming' on page 16).
2. ▶ Keep [RECORD] pressed and press [FLASH 5] (5 minute mode) three times or [FLASH 10] (10 minute mode).
3. ▶ [5MIN] or [10MIN] lights up, indicating which setting has been made.
4. ▶ Exit the mode. To do so, press [REC EXIT] while keeping [RECORD] pressed.

8 MIDI and DMX channel settings

8.1 MIDI

8.1.1 Setting MIDI IN

1. ➤ Activate the programming (↪ Chapter 7.1.1 'Enabling programming' on page 16).
2. ➤ Press and hold [RECORD].
3. ➤ Additionally, press [FLASH 1] three times.
 - ⇒ The display shows 'CHI'.
 - The MIDI IN channel setup is now available.
4. ➤ To assign [MIDI OUT] to a channel 1 - 16, press [FLASH 1-16].
 - ⇒ The corresponding LED lights up.

8.1.2 Exiting MIDI settings

1. ➤ Keep [RECORD] pressed.
2. ➤ To do so, press [REC EXIT].

8.1.3 Receiving MIDI file

1. ➤ Activate the programming (↪ Chapter 7.1.1 'Enabling programming' on page 16).
2. ➤ Keep [RECORD].
3. ➤ To do so, press [FLASH 3] three times.
 - ⇒ The display shows 'IN'.
 - The controller can now receive MIDI files.



During the data exchange, no other functions are available. The functions are automatically available again as soon as the data exchange is complete.



The data exchange is interrupted as soon as errors occur or the device is switched off.

8.1.4 Sending MIDI file

1. ➤ Activate the programming (↪ Chapter 7.1.1 'Enabling programming' on page 16).
2. ➤ Keep [RECORD] pressed.
3. ➤ Press [FLASH 4] three times.
⇒ The display shows 'OUT'.

The controller can now send MIDI files.



During the data exchange, no other functions are available. The functions are automatically available again as soon as the data exchange is complete.



The data exchange is interrupted as soon as errors occur or the device is switched off.

8.1.5 Implementation

- During the reception and transmission of MIDI files, all automatically running MIDI scenes and channels are stopped for 10 minutes .
- While receiving and sending MIDI data, the device automatically searches for or sends an ID of 55H(85), a file named **DC1224** with the addition **BIN(SPACE)**.
- Data can be transferred to another device or to a MIDI device.
- There are two different ways to transfer data.

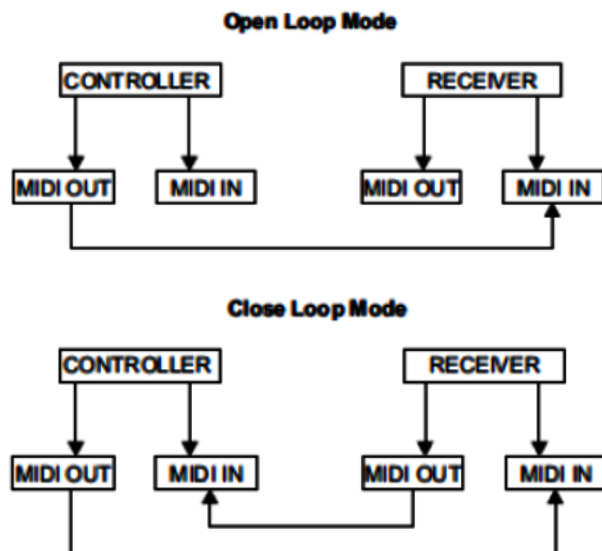

- The controller sends and receives **Note On** and **Note Off** data via the *[Flash]* buttons.

Note No.	Touch velocity	Functions
22-69	Programme master	Turns programmes 1-48 on or off.
70-93	Channel intensity	Activates channel 1-24.
94		Full on
95		Dark
96		Hold
97		Turns audio on or off.
98		CHNS< >SCENES
99		'Double Preset' mode
100		'Single Preset' mode
101		Step
102		Black out

8.2 DMX

8.2.1 DMX channel settings

- Activate the programming (↪ Chapter 7.1.1 'Enabling programming' on page 16).
- Keep *[RECORD]* pressed.
- Press *[FLASH 8]* three times.
 - ⇒ The display shows the current DMX channel.
- Use *[UP]* and *[DOWN]* to select a DMX channel between 1-512.
- Then press the desired *[FLASH]* button between 1-24.
 - ⇒ The selected DMX channel is assigned to the console
- If you press *[FULL ON]* the highest value '255' will be output in the current DMX channel.
 - ⇒ All *[FLASH]* LEDs light up.
- If you press *[BLACK OUT]* the lowest value '000' will be output in the current DMX channel.
 - ⇒ All *[FLASH]* LEDs turn off.
- To quit the Setup mode, keep *[RECORD]* pressed and additionally press *[EXIT]*.

8.2.2 Deleting the DMX channel settings

1. ▶ Activate the programming (↪ *Chapter 7.1.1 'Enabling programming' on page 16*).
2. ▶ Keep *[RECORD]* pressed.
3. ▶ Press *[FLASH 7]* three times.
⇒ All DMX channel settings will be deleted and reset to factory settings.

8.2.3 Calling up 12 preprogrammed programmes

1. ▶ Activate the programming (↪ *Chapter 7.1.1 'Enabling programming' on page 16*).
2. ▶ Keep *[RECORD]* pressed.
3. ▶ Successively press *[FLASH 6]*, *[FLASH 6]*, *[FLASH 8]* and *[FLASH 8]*.
⇒ 12 preprogrammed programmes are loaded to 'PAGE 1', all other programs are deleted.

9 Quick Start Guide for the main functions

9.1 Reversing scene direction

To reverse the direction of all scenes:

- Press *[ALL REV]*.
- ⇒ All scenes change their direction.

To reverse the chase direction of all programmes using the speed control:

- Press *[CHASE REV]*.

To reverse the chase direction of all programmes with standard beat:

- Press *[BEAT REV]*.

To reverse the chase direction of a particular programme:

1. ➤ Keep *[REC ONE]* pressed.
2. ➤ Press the *[FLASH]* button of the respective programme.
3. ➤ Release both buttons simultaneously.

9.2 Setting Fade time

The time setting determines how long the dimmer will take to get from minimum to maximum output.

'Fade Time' can be set via *[FADE TIME]*. Adjustable from 'immediately' up to 10 minutes.

9.3 Using TAP SYNC

[TAP SYNC] is used to set and synchronize the chase rate (the speed of the chases) by pressing it several times. The chase speed is set by the interval of the last two key-strokes. The LED flashes at the new speed. The chase rate can be set at any time, whether a programme is set or not.

[TAP SYNC] overwrites all previously made speed controller settings until it is moved again. This also applies to preset standard beat.

9.4 Using MASTER fader

[MASTER] allows proportional control over all channels and scenes except the [FLASH] buttons. For example:

If the master fader is in the zero position, the output will also be zero, unless [FLASH] or [FULL ON] is used. If the master fader is set to 50 % , the output of a channel will also be at 50 % , unless [FLASH] or [FULL ON] is used.

When the master fader is in its highest position, all device settings can be used.

9.5 Selecting 'Single' mode.

All programmes run sequentially and start at the lowest number.

The number of the currently running programme is shown in the display.

All programmes are controlled with the same speed controller.

1. ➤ To select [CHNS⟨⟩SCENES] , press [Mode Select].
2. ➤ Press [PARK] and use [SINGLE] to select the 'Single Chase' mode.
⇒ A red LED lights up.

9.6 'Mix' mode

All programs run synchronously.

All programs are controlled with the same speed controller or the speed of each program can be individually controlled . ↪ Chapter 7.3.3 'Setting the programme speed with fader' on page 22.

1. ➤ Press [MODE SELECT] to select [CHNS⟨⟩SCENES] .
2. ➤ Press [PARK] and use [MIX CHASE] to select the 'Single Chase' mode.
⇒ A red LED lights up.

9.7 Dimmer Display

The display is used to display the percentage or absolute DMX value.

To switch between the percentage and absolute display:

1. ➤ Keep [SHIFT] pressed.
2. ➤ To switch between the percentage and absolute display, press [% OR 0-255].

9.8 BLIND and HOME

[BLIND] temporarily removes a channel from a chase when it is playing, and allows you to manually control that chase.

To switch to Blind mode:

1. ➤ Keep [BLIND] pressed and press the [FLASH] button associated with the channel that is temporarily removed from the Chase.
2. ➤ To return to normal chase, keep [BLIND] pressed and press the respective [FLASH] button.

9.9 PARK

When the device is in [CHNS] SCENES mode, keep [PARK] pressed to switch between 'Single' and 'Mix' mode.

When the device is in 'Double Preset' mode, press [PARK] simultaneously together with [MASTER B].

In 'Single Preset' mode, the current output can be recorded. Settings are made with [MASTER B].

9.10 ADD/KILL

[ADD/KILL] changes the mode of the 'Flash' buttons. Normally, the 'Flash' buttons are in 'Add' mode. Pressing [FLASH] does not deactivate a scene, different scenes can run at the same time.

'Kill' mode is activated by pressing [ADD/KILL], the LED above it lights up. By pressing [FLASH], any other active scene or programme is disabled.

In 'Kill' mode, the disabled programme is not stopped, but it can not be output.

9.11 Double Preset

1. ➤ To enter the "A Double Preset" mode, press [MODE SELECT].
2. ➤ In this mode, channel faders 1-12 as well as faders 13-24 control channels 1-12.
3. ➤ With [MASTER A] the faders 1-12 are controlled, with [MASTER B] faders 13-24.



In this mode, no scene can be recorded.

Example

- 1.** ▶ Change to the 'Double Preset' mode ↪ *Chapter 9.11 'Double Preset' on page 29.*
- 2.** ▶ Set faders 1-6 to the highest position, as well as 19-24.
- 3.** ▶ Set both *[MASTER A]* and *[MASTER B]* equally.
⇒ You now have a scene.

10 Technical specifications

Voltage supply	Plug-in power supply (12 – 20 V $\overline{\text{AC}}$ / 500 mA min.)
DMX output	3-pin XLR chassis socket
MIDI signal	5-pin standard connectors
Audio input	RCA socket, 100 mV, 1 V _{pp}
Fuse (internal)	5 mm 20 mm, 0.5 A, 250 V, fast-acting
Dimensions (W × H × D)	482 mm × 85 mm × 264 mm (25.12in. × 26.14in. × 4.48in.)
Weight	4.6 kg

11 Plug and connection assignments

Introduction

This chapter will help you select the right cables and plugs to connect your valuable equipment so that a perfect light experience is guaranteed.

Please take our tips, because especially in 'Sound & Light' caution is indicated: Even if a plug fits into a socket, the result of an incorrect connection may be a destroyed DMX controller, a short circuit or 'just' a not working light show!

DMX connections

The unit offers a 3-pin XLR socket for DMX output and a 3-pin XLR plug for DMX input. Please refer to the drawing and table below for the pin assignment of a suitable XLR plug.



Pin	Configuration
1	Ground, shielding
2	Signal inverted (DMX-, 'cold signal')
3	Signal (DMX+, 'hot signal')

12 Protecting the environment

Disposal of the packaging material



For the transport and protective packaging, environmentally friendly materials have been chosen that can be supplied to normal recycling.

Ensure that plastic bags, packaging, etc. are properly disposed of.

Do not just dispose of these materials with your normal household waste, but make sure that they are collected for recycling. Please follow the notes and markings on the packaging.

Disposal of your old device



This product is subject to the European Waste Electrical and Electronic Equipment Directive (WEEE) in its currently valid version. Do not dispose with your normal household waste.

Dispose of this device through an approved waste disposal firm or through your local waste facility. When discarding the device, comply with the rules and regulations that apply in your country. If in doubt, consult your local waste disposal facility.

