



**the  
t.amp**

E4-130, E4-250  
power amplifier

Musikhaus Thomann  
Thomann GmbH  
Hans-Thomann-Straße 1  
96138 Burgebrach  
Germany  
Telephone: +49 (0) 9546 9223-0  
E-mail: [info@thomann.de](mailto:info@thomann.de)  
Internet: [www.thomann.de](http://www.thomann.de)

10.04.2019, ID: 348232, 348233 (V3)

# Table of contents

<b>1</b>	<b>General information</b> .....	<b>4</b>
	1.1 Further information.....	5
	1.2 Notational conventions.....	6
	1.3 Symbols and signal words.....	6
<b>2</b>	<b>Safety instructions</b> .....	<b>8</b>
<b>3</b>	<b>Features</b> .....	<b>13</b>
<b>4</b>	<b>Installation and starting up</b> .....	<b>14</b>
<b>5</b>	<b>Connections and operating elements</b> .....	<b>19</b>
<b>6</b>	<b>Technical specifications</b> .....	<b>25</b>
<b>7</b>	<b>Plug and connection assignment</b> .....	<b>30</b>
<b>8</b>	<b>Cleaning</b> .....	<b>33</b>
<b>9</b>	<b>Protecting the environment</b> .....	<b>34</b>

# 1 General information

This user manual contains important information on the safe operation of the device. Read and follow all safety notes and all instructions. Save this manual for future reference. Make sure that it is available to all persons using this device. If you sell the device to another user, be sure that they also receive this manual.

Our products and user manuals are subject to a process of continuous development. We therefore reserve the right to make changes without notice. Please refer to the latest version of the user manual which is ready for download under [www.thomann.de](http://www.thomann.de).

## 1.1 Further information

On our website ([www.thomann.de](http://www.thomann.de)) you will find lots of further information and details on the following points:

Download	This manual is also available as PDF file for you to download.
Keyword search	Use the search function in the electronic version to find the topics of interest for you quickly.
Online guides	Our online guides provide detailed information on technical basics and terms.
Personal consultation	For personal consultation please contact our technical hotline.
Service	If you have any problems with the device the customer service will gladly assist you.

## 1.2 Notational conventions

This manual uses the following notational conventions:



### Letterings

The letterings for connectors and controls are marked by square brackets and italics.

**Examples:** *[VOLUME]* control, *[Mono]* button.

## 1.3 Symbols and signal words

In this section you will find an overview of the meaning of symbols and signal words that are used in this manual.

Signal word	Meaning
<b>DANGER!</b>	This combination of symbol and signal word indicates an immediate dangerous situation that will result in death or serious injury if it is not avoided.
<b>CAUTION!</b>	This combination of symbol and signal word indicates a possible dangerous situation that can result in minor injury if it is not avoided.
<b>NOTICE!</b>	This combination of symbol and signal word indicates a possible dangerous situation that can result in material and environmental damage if it is not avoided.
Warning signs	Type of danger
	Warning – high-voltage.
	Warning – danger zone.

## 2 Safety instructions

### Intended use

This device amplifies electric audio frequency signals to operate passive speakers. Use the device only as described in this user manual. Any other use or use under other operating conditions is considered to be improper and may result in personal injury or property damage. No liability will be assumed for damages resulting from improper use.

This device may be used only by persons with sufficient physical, sensorial, and intellectual abilities and having corresponding knowledge and experience. Other persons may use this device only if they are supervised or instructed by a person who is responsible for their safety.

### Safety



#### **DANGER!**

#### **Danger for children**

Ensure that plastic bags, packaging, etc. are disposed of properly and are not within reach of babies and young children. Choking hazard!

Ensure that children do not detach any small parts (e.g. knobs or the like) from the unit. They could swallow the pieces and choke!

Never let children unattended use electrical devices.





**DANGER!**

**Electric shock caused by high voltages inside**

Within the device there are areas where high voltages may be present. Never remove any covers.

There are no user-serviceable parts inside.

Do not use the device if covers, protectors or optical components are missing or damaged.



**DANGER!**

**Electric shock caused by short-circuit**

Always use proper ready-made insulated mains cabling (power cord) with a protective contact plug. Do not modify the mains cable or the plug. Failure to do so could result in electric shock/death or fire. If in doubt, seek advice from a registered electrician.



**CAUTION!**

**Possible hearing damage**

With loudspeakers or headphones connected, the device can produce volume levels that may cause temporary or permanent hearing impairment.

Do not operate the device permanently at a high volume level. Decrease the volume level immediately if you experience ringing in your ears or hearing impairment.



**NOTICE!**

**Risk of fire**

Do not block areas of ventilation. Do not install the device near any direct heat source. Keep the device away from naked flames.

**NOTICE!****Operating conditions**

This device has been designed for indoor use only. To prevent damage, never expose the device to any liquid or moisture. Avoid direct sunlight, heavy dirt, and strong vibrations.

Only operate the device within the ambient conditions specified in the chapter 'Technical specifications' of this user manual. Avoid heavy temperature fluctuations and do not switch the device on immediately after it was exposed to temperature fluctuations (for example after transport at low outside temperatures).

Dust and dirt inside can damage the unit. When operated in harmful ambient conditions (dust, smoke, nicotine, fog, etc.), the unit should be maintained by qualified service personnel at regular intervals to prevent overheating and other malfunction.



### **NOTICE!**

#### **Power supply**

Before connecting the device, ensure that the input voltage (AC outlet) matches the voltage rating of the device and that the AC outlet is protected by a residual current circuit breaker. Failure to do so could result in damage to the device and possibly injure the user.

Unplug the device before electrical storms occur and when it is unused for long periods of time to reduce the risk of electric shock or fire.



### **NOTICE!**

#### **Magnetic fields**

The device generates strong magnetic fields that can interfere with the function of poorly shielded devices. The strongest magnetic fields are directly above and below the power amplifier. Therefore, never place sensitive devices such as pre-amplifiers, radio transmission systems, or tape decks directly above or below the power amplifier. When installing the power amplifier into a rack, you should place it in the lowest position, and further equipment such as pre-amplifiers in the highest position.

### 3 Features

- Low mounting depth of only 408 mm
- Output power
  - the t.amp E4-130 (item no. 348232):  
4 × 130 W @ 8 Ω, 4 × 200 W @ 4 Ω
  - the t.amp E4-250 (item no. 348233):  
4 × 400 W @ 4 Ω, 4 × 250 W @ 8 Ω
- Inputs: XLR
- Outputs: NL4 (speakON) connectors for speakers
- Protection circuits: DC, short circuit, overtemperature, limiter, soft start
- Defeatable standby function

## 4 Installation and starting up

Unpack and check carefully there is no transportation damage before using the unit. Keep the equipment packaging. To fully protect the product against vibration, dust and moisture during transportation or storage use the original packaging or your own packaging material suitable for transport or storage, respectively.

Create all connections while the device is off. Use the shortest possible high-quality cables for all connections. Take care when running the cables to prevent tripping hazards.



### **DANGER!**

#### **Electric shock caused by high voltages at the power amplifier output**

The output voltages of modern high-performance amplifiers may result in death or serious injury.

Never touch the bare ends of loudspeaker cables when the amplifier is on.



**NOTICE!**

**Magnetic fields**

The device generates strong magnetic fields that can interfere with the function of poorly shielded devices. The strongest magnetic fields are directly above and below the power amplifier. Therefore, never place sensitive devices such as pre-amplifiers, radio transmission systems, or tape decks directly above or below the power amplifier. When installing the power amplifier into a rack, you should place it in the lowest position, and further equipment such as pre-amplifiers in the highest position.

The following section explains the possible operating modes of the device. Channels 1 and 3 are marked there with 'A' and channels 2 and 4 are marked with 'B'.

### Available operating modes

Depending on the individual application, the amplifier can be used in different operation modes:

#### Stereo mode

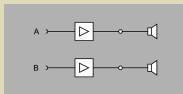

Both power amp channels operate independently of each other, each input (A and B) is amplified by one channel, speakers are connected to both channels, the volume for both outputs can be controlled separately.

#### Parallel mode

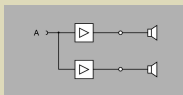

Both power amp channels amplify the signal from input A, speakers are connected to both channels, the volume controls of channels A and B are used to control the volume.

#### Bridged mode



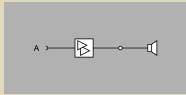

Both power amp channels are internally wired for providing double the output power. Only the signal from input A is amplified, speakers are only connected to the accordingly labelled output. The controls for channel A and channel B are used to adjust the volume.

The phase of the second or fourth channel is reversed. The speaker must be operated using a Y-adaptor cable to CH1 1+ to 1+ and CH2 1+ to 1-, see figure below.

### Speaker connection in bridged mode

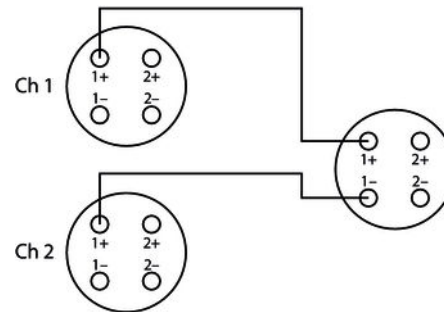

E4-130, E4-250

### **Total impedance**

On each output of the amplifier, the overall impedance resulting from the individual impedances of the connected speakers must not fall below the minimum allowable impedance of the amp's output. If you want to connect multiple speakers to one amplifier output, note the following:

- when connecting speakers in series, the impedances add up.
- when connecting speakers in parallel, the reciprocal value of the total impedance is equal to the sum of the reciprocal values of the individual impedances.

This means, for example with two speakers with the same impedance: In series connection, impedance is doubled. In parallel connection, it's halved.

Detailed information on this topic can be found in our online guide 'Speakers' ([www.thomann.de](http://www.thomann.de)).

### **Rack mounting**

The device has been designed for rack mounting in a standard 19-inch rack; it occupies two rack units.

## 5 Connections and operating elements

### Front panel

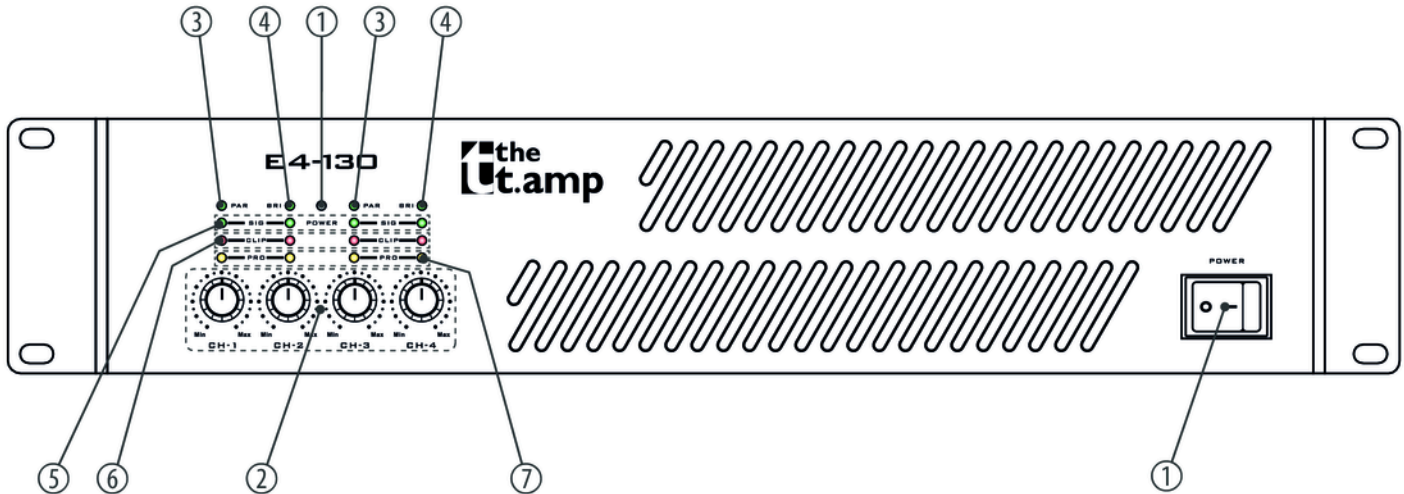

E4-130, E4-250

1	<i>[POWER]</i>	Mains switch. Turns the device on and off. The corresponding LED lights up green when the device is turned on. In standby mode, the LED lights red. As soon as the unit receives a signal, it switches back to normal mode and the LED will light up green again.
2	<i>[CH-1], [CH-2], [CH-3], [CH-4]</i>	Volume control for the respective channel
3	<i>[PAR]</i>	Lights up when the respective channel pair is operated in Parallel mode.
4	<i>[BRI]</i>	Lights up when the respective channel pair is operated in Bridged mode.
5	<i>[SIG]</i>	Indicates the presence of an input signal.

6	<i>[CLIP]</i>	<p>Lights under the following conditions:</p> <ul style="list-style-type: none"> <li>■ Channel overload. Reduce in this case the volume until the LED goes out.</li> <li>■ Output short circuit. Turn off the device immediately, correct the short circuit and turn on the device again.</li> </ul>
7	<i>[PRO]</i>	<p>Lights under the following conditions:</p> <ul style="list-style-type: none"> <li>■ Three to five seconds after switching on or off when the device is in an unstable condition.</li> <li>■ No speaker connected.</li> <li>■ The temperature of the power amp blocks has reached 85 °C.</li> <li>■ One or more protection circuits have been triggered, or the device is faulty.</li> </ul>

Rear panel

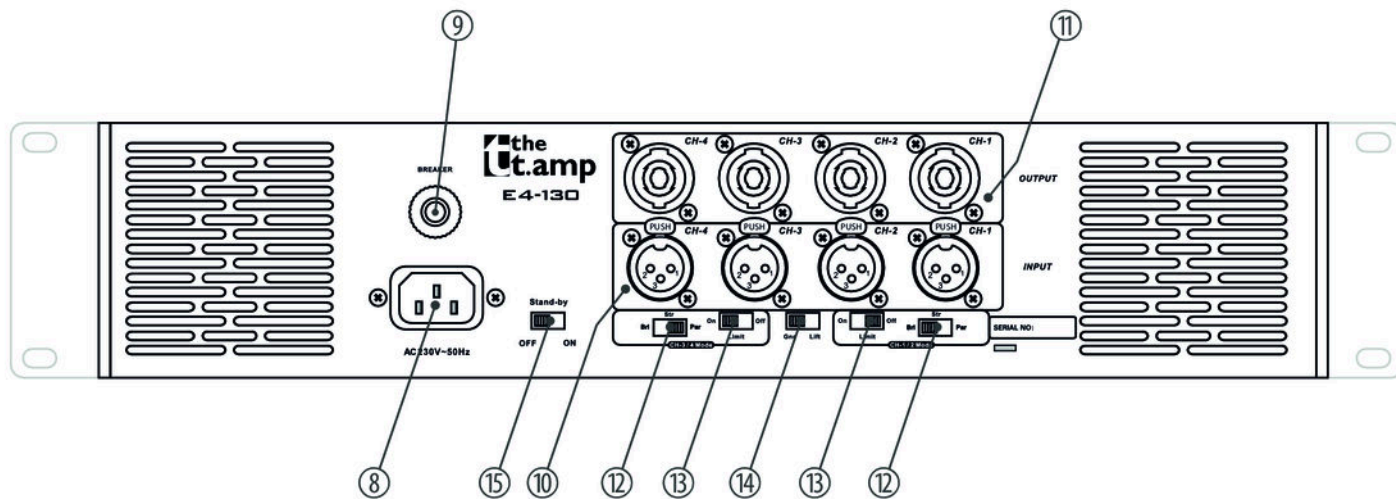

8	IEC chassis connector for the power supply of the device.
9	<i>[BREAKER]</i> Resettable electronic fuse. If the fuse is triggered, fix the cause and then push the button to reset the fuse.
10	<i>[INPUT]</i> XLR chassis sockets as inputs for channels 1 to 4
11	<i>[OUTPUT]</i> Speaker Twist chassis connectors for speaker outputs (1+, 2+: positive; 1, 2-: negative) for channels 1 to 4
12	Selector switch for the operating mode of the respective channel pair <ul style="list-style-type: none"> <li>■ Par: Parallel mode</li> <li>■ Str: Stereo mode</li> <li>■ Bri: Bridged mode</li> </ul>
13	<i>[LIMIT]</i> Limits the output level so that the distortion is at most 5%.

14 *[Gnd / Lift]*

Ground / lift switch. If hum is caused by a ground loop, you can use this switch to disconnect the connection between the earth pin of the device and the signal ground of the device.

15 *[Stand-by ON | OFF]*

On / off switch for standby function. If the standby function is enabled, the device automatically switches to standby mode after thirty minutes without any input signal.



## 6 Technical specifications

### E4-130 (item no. 348232)

Amp class	AB	
Input impedance	20 k $\Omega$ (balanced) 10 k $\Omega$ (unbalanced)	
Output power	8 $\Omega$ , stereo	4 $\times$ 130 W RMS
	4 $\Omega$ , stereo	4 $\times$ 200 W RMS
	8 $\Omega$ , bridged	2 $\times$ 400 W RMS
Frequency response, $\pm 0,5$ dB	20 Hz ... 20 kHz	
Signal-to-noise ratio	$\geq 94$ dB	
Total harmonic distortion (THD)	$\leq 0,05$ %	
Crosstalk (at rated power @ 8 $\Omega$ , 1 kHz)	$> 64$ dB	
Damping factor (at rated power @ 8 $\Omega$ , 1 kHz)	$> 200$	

## Technical specifications

---

Slew rate	15 V / $\mu$ s	
Sensitivity	1000 mV	
Gain	-55 dB ... 30 dB	
Power consumption	1500 W	
Operating supply voltage	230 V ~ 50 Hz	
Dimensions (W x H x D)	482 mm x 88 mm x 408 mm	
Weight	12.9 kg	
Ambient conditions	Temperature range	0 °C...40 °C
	Relative humidity	50 %, non-condensing

**E4-250 (item no. 348233)**

Amp class	AB	
Input impedance	20 k $\Omega$ (balanced) 10 k $\Omega$ (unbalanced)	
Output power	8 $\Omega$ , stereo	4 $\times$ 250 W RMS
	4 $\Omega$ , stereo	4 $\times$ 400 W RMS
	8 $\Omega$ , bridged	2 $\times$ 800 W RMS
Frequency response, $\pm 0,5$ dB	20 Hz ... 20 kHz	
Signal-to-noise ratio	$\geq 94$ dB	
Total harmonic distortion (THD)	$\leq 0,05$ %	
Crosstalk (at rated power @ 8 $\Omega$ , 1 kHz)	$> 64$ dB	
Damping factor (at rated power @ 8 $\Omega$ , 1 kHz)	$> 200$	
Slew rate	15 V / $\mu$ s	
Sensitivity	1000 mV	

## Technical specifications

---

Gain	-52 dB ... 33 dB	
Power consumption	2700 W	
Operating supply voltage	230 V ~ 50 Hz	
Dimensions (W × H × D)	482 mm × 88 mm × 408 mm	
Weight	15.0 kg	
Ambient conditions	Temperature range	0 °C...40 °C
	Relative humidity	50 %, non-condensing

**Further information**

Channels	4
19" installation height	2 RU
2 $\Omega$ stable	No
DSP / crossover	No
Convection cooling	No

## 7 Plug and connection assignment

### Introduction

This chapter will help you select the right cables and plugs to connect your valuable equipment in such a way that a perfect sound experience is ensured.

Please note these advices, because especially in 'Sound & Light' caution is indicated: Even if a plug fits into the socket, an incorrect connection may result in a destroyed power amp, a short circuit or 'just' in poor transmission quality!

### Balanced and unbalanced transmission

Unbalanced transmission is mainly used in semi-professional environment and in hifi use. Instrument cables with two conductors (one core plus shielding) are typical representatives of the unbalanced transmission. One conductor is ground and shielding while the signal is transmitted through the core.

Unbalanced transmission is susceptible to electromagnetic interference, especially at low levels, such as microphone signals and when using long cables.

In a professional environment, therefore, the balanced transmission is preferred, because this enables an undisturbed transmission of signals over long distances. In addition to the conductors 'Ground' and 'Signal', in a balanced transmission a second core is added. This also transfers the signal, but phase-shifted by 180°.

Since the interference affects both cores equally, by subtracting the phase-shifted signals, the interfering signal is completely neutralized. The result is a pure signal without any noise interference.

**XLR plug (balanced)**

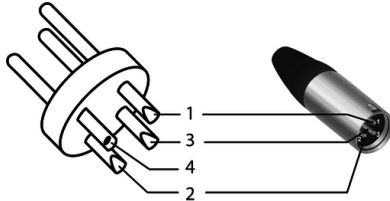

1	Ground, shielding
2	Signal (in phase, +)
3	Signal (out of phase, -)
4	Shielding on plug housing (option)

## XLR plug (unbalanced)

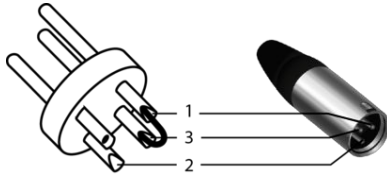

1	Ground, shielding
2	Signal
3	Bridged to pin 1

## Speaker Twist connector

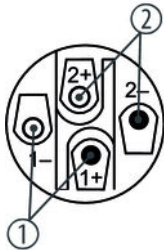

1, +	Signal 1 (in phase)
1, -	Signal 1 (out of phase)
2, +	NC (not connected)
2, -	NC (not connected)



## 8 Cleaning

### Fan grids

The fan grids of the device must be cleaned of any contamination, such as dust, etc. on a regular basis. Before cleaning, switch off the device and disconnect mains-operated devices from the mains. Only use pH-neutral, solvent-free and non-abrasive cleaning agents. Clean the unit with a slightly damp lint-free cloth.

## 9 Protecting the environment

### Disposal of the packaging material



For the transport and protective packaging, environmentally friendly materials have been chosen that can be supplied to normal recycling.

Ensure that plastic bags, packaging, etc. are properly disposed of.

Do not just dispose of these materials with your normal household waste, but make sure that they are collected for recycling. Please follow the notes and markings on the packaging.

### Disposal of your old device



This product is subject to the European Waste Electrical and Electronic Equipment Directive (WEEE) in its currently valid version. Do not dispose with your normal household waste.

Dispose of this device through an approved waste disposal firm or through your local waste facility. When discarding the device, comply with the rules and regulations that apply in your country. If in doubt, consult your local waste disposal facility.



