



Achat 204 A

Active Speaker

Thomann GmbH

Hans-Thomann-Straße 1

96138 Burgebrach

Germany

Telephone: +49 (0) 9546 9223-0

Internet: www.thomann.de

18.03.2024, ID: 375150 (V3)

Table of contents

1	General information	5
	1.1 Symbols and signal words.....	5
2	Safety instructions	7
3	Features	10
4	Installation	11
	4.1 Tips on handling speakers.....	13
5	Connections and controls	14
6	Technical specifications	16
7	Plug and connection assignment	21
8	Protecting the environment	23





1 General information

This document contains important instructions for the safe operation of the product. Read and follow the safety instructions and all other instructions. Keep the document for future reference. Make sure that it is available to all those using the product. If you sell the product to another user, be sure that they also receive this document.

Our products and documentation are subject to a process of continuous development. They are therefore subject to change. Please refer to the latest version of the documentation, which is ready for download under www.thomann.de.

1.1 Symbols and signal words

In this section you will find an overview of the meaning of symbols and signal words that are used in this document.

Signal word	Meaning
DANGER!	This combination of symbol and signal word indicates an immediate dangerous situation that will result in death or serious injury if it is not avoided.
WARNING!	This combination of symbol and signal word indicates a possible dangerous situation that can result in death or serious injury if it is not avoided.
NOTICE!	This combination of symbol and signal word indicates a possible dangerous situation that can result in material and environmental damage if it is not avoided.
Warning signs	Type of danger
	Warning – high-voltage.
	Warning – suspended load.
	Warning – danger zone.

2 Safety instructions

Intended use

This device is designed as a PA system. The device is designed for professional use only and is not suitable for use in households. Use the device only as described in this user manual. Any other use or use under other operating conditions is considered to be improper and may result in personal injury or property damage. No liability will be assumed for damages resulting from improper use.

This device may be used only by persons with sufficient physical, sensorial, and intellectual abilities and having corresponding knowledge and experience. Other persons may use this device only if they are supervised or instructed by a person who is responsible for their safety.

Safety



DANGER!

Risk of injury and choking hazard for children!

Children can suffocate on packaging material and small parts. Children can injure themselves when handling the device. Never allow children to play with the packaging material and the device. Always store packaging material out of the reach of babies and small children. Always dispose of packaging material properly when it is not in use. Never allow children to use the device without supervision. Keep small parts away from children and make sure that the device does not shed any small parts (such knobs) that children could play with.



DANGER!

Danger to life due to electric current!

Within the device there are areas where high voltages may be present. Never remove any covers. There are no user-serviceable parts inside. Do not use the device when covers, safety equipment or optical components are missing or damaged.



DANGER!

Danger to life due to electric current!

A short circuit could lead to a fire hazard and risk of death. Always use proper ready-made insulated triple-core mains cable with a safety plug. Do not modify the mains cable or the plug. In case of isolation damage, disconnect immediately the power supply and arrange repair. If in doubt, seek advice from a qualified electrician.



WARNING!

Risk of injury due to improper installation!

Improper mounting can lead to serious injuries and significant damage to property. When installing and operating, make sure to follow the standards and regulations that apply in your country. In Germany, this is DGUV regulation 17 "Staging and Production Facilities for the Entertainment Industry". Ensure that speakers are only mounted by trained specialists.



WARNING!

Risk of injury from falling speakers that were inadequately secured!

If speakers are not properly secured when mounted, they can cause severe injury and considerable damage by falling. Always secure portable sound systems (speakers) with two independent safety devices, for example with safety cables.



WARNING!

Possible hearing damage due to operating the device at a high volume!

The device can produce volume levels that, when operated at a high volume, may cause temporary or permanent hearing impairment. Over an extended period of time, even levels that seem to be uncritical can cause hearing damage. Avoid operating the device at excessively high volumes over an extended period of time. Decrease the volume level immediately if you experience ringing in your ears or hearing impairment. If this is not possible, keep a greater distance or use adequate ear-muffs.



NOTICE!

Risk of fire due to covered vents and neighbouring heat sources!

If the vents of the device are covered or the device is operated in the immediate vicinity of other heat sources, the device can over-heat and burst into flames. Never cover the device or the vents. Do not install the device in the immediate vicinity of other heat sources. Never operate the device in the immediate vicinity of naked flames.

NOTICE!**Damage to the device if operated in unsuitable ambient conditions!**

The device can be damaged if it is operated in unsuitable ambient conditions. Only operate the device indoors within the ambient conditions specified in the "Technical specifications" chapter of this user manual. Avoid operating it in environments with direct sunlight, heavy dirt and strong vibrations. Avoid operating it in environments with strong temperature fluctuations. If temperature fluctuations cannot be avoided (for example after transport in low outside temperatures), do not switch on the device immediately. Never subject the device to liquids or moisture. Never move the device to another location while it is in operation. In environments with increased dirt levels (for example due to dust, smoke, nicotine or mist): Have the device cleaned by qualified specialists at regular intervals to prevent damage due to overheating and other malfunctions.

NOTICE!**Damage to the device due to high voltages!**

The device can be damaged if it is operated with the incorrect voltage or if high voltage peaks occur. In the worst case, excess voltages can also cause a risk of injury and fires. Make sure that the voltage specification on the device matches the local power grid before plugging in the device. Only operate the device from professionally installed mains sockets that are protected by a residual current circuit breaker (FI). As a precaution, disconnect the device from the power grid when storms are approaching or if the device will not be used for a longer period.

NOTICE!**Risk of fire due to installation of a wrong fuse!**

Using fuses of a different type than compatible with the device may cause a fire and seriously damage the device. Only use fuses of the same type. Observe the labelling on the device casing and the information in the "Technical data" chapter.

NOTICE!**Possible staining due to plasticiser in rubber feet!**

The plasticiser contained in the rubber feet of this product may react with the coating of the floor and cause permanent dark stains after some time. If necessary, use a suitable mat or felt slide to prevent direct contact between the device's rubber feet and the floor.

3 Features

- Active mini speaker with two 4-inch woofers and 1-inch tweeter
- 3/8-inch thread for stands
- Optional wall mount available (item no. 269439, item no. 269440)
- Black textured paint
- Power-saving mode

4 Installation

Unpack and check carefully there is no transportation damage before using the unit. Keep the equipment packaging. To fully protect the product against vibration, dust and moisture during transportation or storage use the original packaging or your own packaging material suitable for transport or storage, respectively.

Create all connections while the device is off. Use the shortest possible high-quality cables for all connections. Take care when running the cables to prevent tripping hazards.



WARNING!

Risk of injury due to improper installation!

Improper mounting can lead to serious injuries and significant damage to property.

When installing and operating, make sure to follow the standards and regulations that apply in your country. In Germany, this is DGUV regulation 17 "Staging and Production Facilities for the Entertainment Industry".

Ensure that speakers are only mounted by trained specialists.



WARNING!

Risk of injury from falling speakers that were inadequately secured!

If speakers are not properly secured when mounted, they can cause severe injury and considerable damage by falling.

Always secure portable sound systems (speakers) with two independent safety devices, for example with safety cables.



NOTICE!

Possible property damage to adjacent devices due to magnetic fields.

Speakers generate a static magnetic field. This magnetic field can affect other neighbouring units and in unfavourable cases damage them.

Ensure that speakers are always a sufficient distance away from sensitive equipment that may be affected by an external magnetic field.



NOTICE!

Potential property damage due to unsuitable stands!

If the device is mounted on an unsuitable stand, there is a risk that the stand will fall over and cause damage.

Only use stands whose maximum bearing capacity is at least as high as the weight of the device. Always ensure that the stand is stable.

4.1 Tips on handling speakers

We recommend you to set up the speakers in a way, that the sound signals can reach the audience unobstructedly. It will often be helpful to mount the speakers on tripods. Thus, the sound will be evenly spread with maximum range throughout the audience area.

Always use high grade cable to connect your equipment. Otherwise you won't reach maximum sound quality.

If you notice distortion during operation, the active speaker is overloaded. This may permanently damage the device. Always reduce the volume as soon as you hear distortion.

5 Connections and controls

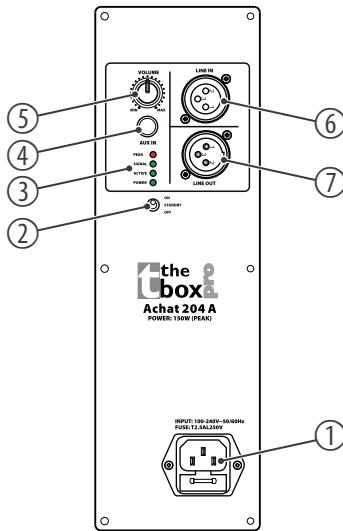

- 1 Rubber panel plug with fuse holder for the power supply
- 2 *[ON/STANDBY/OFF]* | Use this toggle switch (mains switch) to turn the device on (ON), put it into power-saving mode (STANDBY) or turn it off (OFF).

If the speaker box is in power-saving mode and receives no signal for 60 minutes, it switches to standby mode. As soon as the device receives a signal, it automatically switches back to normal mode.

- 3 *[PEAK]* | Indicates overload. If the LED flickers or lights up, the input signal level is too high.

[SIGNAL] | Indicates that an input signal is present.

[ACTIVE] | Power indicator. This LED lights up continuously in normal operation and turns off when the speaker switches to standby mode if power-saving mode is activated.

[POWER] | Standby mode. This LED lights up when the box - on activated power save mode - switches to standby mode and turns off when the box is switched back to normal operation.

- 4 *[AUX IN]* | Cinch socket for connecting line level devices (unbalanced) such as laptops and mobile phones, if necessary using an appropriate adapter

- 5 *[VOLUME]* | Control for adjusting the volume

6 *[LINE IN]* | Line signal input, designed as XLR chassis socket, 3-pin

7 *[LINE OUT]* | Line output for connecting further speakers, designed as XLR plug, 3-pin

6 Technical specifications

Configuration	2 × 4-inch woofer, 1 × 1-inch textile dome tweeter	
Input connections	LINE IN	1 × XLR panel socket, 3-pin
	AUX IN	1 × cinch socket (unbalanced)
	Power supply	Rubber panel plug C14
Input impedance	XLR socket: 20 kΩ (balanced), 10 kΩ (unbalanced)	
	Cinch socket: 10 kΩ (unbalanced)	
Output connections	LINE OUT	1 × XLR chassis plug, 3-pin
Output power	RMS: 80 W	
	Peak: 320 W	
Frequency range	90 Hz ... 20 kHz	
Crossover frequency	1.65 kHz	
Signal-to-noise ratio	Woofer: ≥85 dB	
	Tweeter: ≥80 dB	
Sound pressure level (SPL), max.	112 dB	
Beam angle (H × V)	90° × 90°	

Power consumption	4.7 W	
Supply voltage	100 - 240 V ~ 50/60 Hz	
Fuse	5 mm × 20 mm, 2 A, 250 V, slow blow	
Dimensions (W × H × D)	144 mm × 360 mm × 172 mm	
Weight	4.6 kg	
Ambient conditions	Temperature range	0 °C...40 °C
	Relative humidity	20%...80% (non-condensing)

Further information

Multifunctional housing	No
Flange for stand	Yes
Truss-capable	Yes, M6 thread
Housing material	Wood
Media player	No
Effect	No
Monitor inclination	No
Remote control	No
Low Cut	No

Frequency response

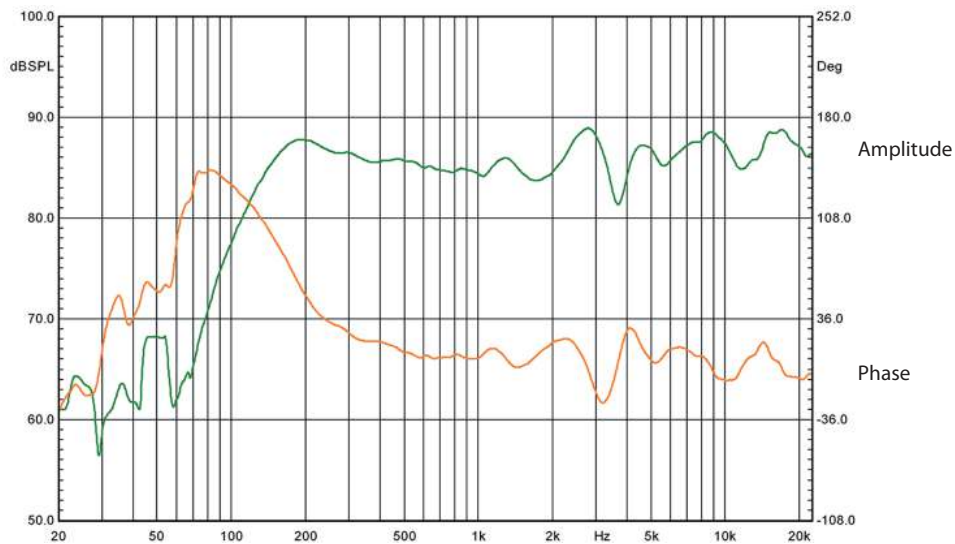

Technical specifications

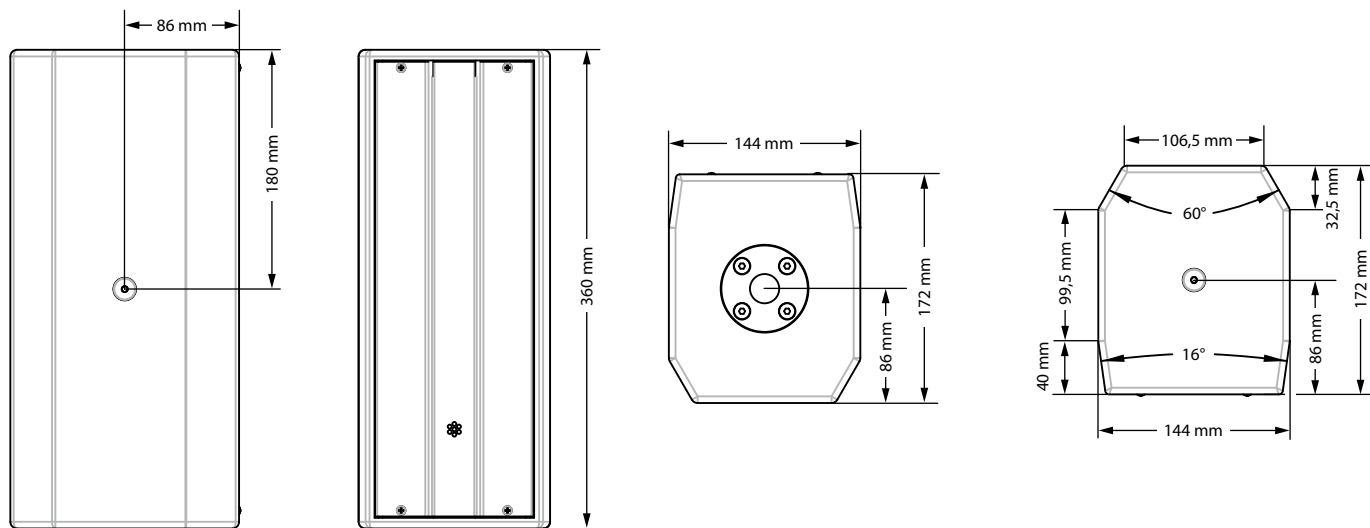

7 Plug and connection assignment

Introduction

This chapter will help you select the right cables and plugs to connect your valuable equipment in such a way that a perfect sound experience is ensured.

Please note these advices, because especially in 'Sound & Light' caution is indicated: Even if a plug fits into the socket, an incorrect connection may result in a destroyed power amp, a short circuit or 'just' in poor transmission quality!

Balanced and unbalanced transmission

Unbalanced transmission is mainly used in semi-professional environment and in hifi use. Instrument cables with two conductors (one core plus shielding) are typical representatives of the unbalanced transmission. One conductor is ground and shielding while the signal is transmitted through the core.

Unbalanced transmission is susceptible to electromagnetic interference, especially at low levels, such as microphone signals and when using long cables.

In a professional environment, therefore, the balanced transmission is preferred, because this enables an undisturbed transmission of signals over long distances. In addition to the conductors 'Ground' and 'Signal', in a balanced transmission a second core is added. This also transfers the signal, but phase-shifted by 180°.

Since the interference affects both cores equally, by subtracting the phase-shifted signals, the interfering signal is completely neutralized. The result is a pure signal without any noise interference.

XLR plug (balanced)

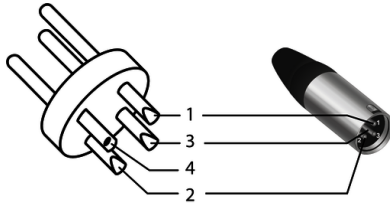

1	Ground, shielding
2	Signal (in phase, +)
3	Signal (out of phase, -)
4	Shielding on plug housing (option)

XLR plug (unbalanced)

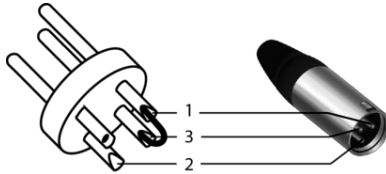

1	Ground, shielding
2	Signal
3	Bridged to pin 1

RCA connection



Drawing and table indicate the pin assignment of an RCA plug.

1	Signal
2	Ground, shielding

8 Protecting the environment

Disposal of the packing material

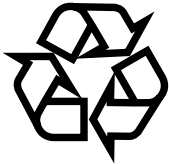

Environmentally friendly materials have been chosen for the packaging. These materials can be sent for normal recycling. Ensure that plastic bags, packaging, etc. are disposed of in the proper manner.

Do not dispose of these materials with your normal household waste, but make sure that they are collected for recycling. Please follow the instructions and markings on the packaging.



Observe the disposal note regarding documentation in France.

Disposal of your old device

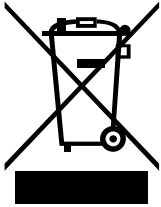

This product is subject to the European Waste Electrical and Electronic Equipment Directive (WEEE) as amended.

Do not dispose of your old device with your normal household waste; instead, deliver it for controlled disposal by an approved waste disposal firm or through your local waste facility. When disposing of the device, comply with the rules and regulations that apply in your country. If in doubt, consult your local waste management facility. Proper disposal protects the environment as well as the health of your fellow human beings.

Also note that waste avoidance is a valuable contribution to environmental protection. Repairing a device or passing it on to another user is an ecologically valuable alternative to disposal.

You can return your old device to Thomann GmbH at no charge. Check the current conditions on www.thomann.de.

If your old device contains personal data, delete those data before disposing of it.

