



LED Typhoon PAR Outdoor 12x10,
LED Typhoon True PAR 12x10 Outdoor

Musikhaus Thomann
Thomann GmbH
Hans-Thomann-Straße 1
96138 Burgebrach
Germany
Telephone: +49 (0) 9546 9223-0
E-mail: info@thomann.de
Internet: www.thomann.de

25.01.2018, ID: 420255

Table of contents

1	General notes	4
	1.1 Further information.....	4
	1.2 Notational conventions.....	4
	1.3 Symbols and signal words.....	5
2	Safety instructions	6
3	Features	8
4	Installation	9
5	Starting up	11
6	Connections and controls	12
7	Operating	16
	7.1 Starting the device.....	16
	7.2 Main menu.....	16
	7.3 Menu overview.....	19
	7.4 Functions in 3-channel DMX mode.....	19
	7.5 Functions in 6-channel DMX mode.....	20
	7.6 Functions in 8-channel DMX mode.....	20
	7.7 Functions in 10-channel DMX mode.....	20
	7.8 Functions in 13-channel DMX mode.....	23
8	Technical specifications	26
9	Plug and connection assignment	27
10	Troubleshooting	28
11	Cleaning	29
12	Protecting the environment	30

1 General notes

This manual contains important instructions for the safe operation of the unit. Read and follow the safety instructions and all other instructions. Keep the manual for future reference. Make sure that it is available to all those using the device. If you sell the unit please make sure that the buyer also receives this manual.

Our products are subject to a process of continuous development. Thus, they are subject to change.

1.1 Further information

On our website (www.thomann.de) you will find lots of further information and details on the following points:

Download	This manual is also available as PDF file for you to download.
Keyword search	Use the search function in the electronic version to find the topics of interest for you quickly.
Online guides	Our online guides provide detailed information on technical basics and terms.
Personal consultation	For personal consultation please contact our technical hotline.
Service	If you have any problems with the device the customer service will gladly assist you.

1.2 Notational conventions

This manual uses the following notational conventions:

Letterings

The letterings for connectors and controls are marked by square brackets and italics.

Examples: *[VOLUME]* control, *[Mono]* button.

Displays

Texts and values displayed on the device are marked by quotation marks and italics.

Examples: '24ch', 'OFF'.

Instructions

The individual steps of an instruction are numbered consecutively. The result of a step is indented and highlighted by an arrow.





Example:

1. ➤ Switch on the device.
2. ➤ Press *[Auto]*.
⇒ Automatic operation is started.
3. ➤ Switch off the device.

1.3 Symbols and signal words

In this section you will find an overview of the meaning of symbols and signal words that are used in this manual.

Signal word	Meaning
DANGER!	This combination of symbol and signal word indicates an immediate dangerous situation that will result in death or serious injury if it is not avoided.
WARNING!	This combination of symbol and signal word indicates a possible dangerous situation that can result in death or serious injury if it is not avoided.
NOTICE!	This combination of symbol and signal word indicates a possible dangerous situation that can result in material and environmental damage if it is not avoided.

Warning signs	Type of danger
	Warning – high-voltage.
	Warning – hot surface.
	Warning – suspended load.
	Warning – danger zone.

2 Safety instructions

Intended use

This device is intended to be used as an electronic illumination effect using LED technics. The device is designed for professional use and is not suitable for use in households. Use the device only as described in this user manual. Any other use or use under other operating conditions is considered to be improper and may result in personal injury or property damage. No liability will be assumed for damages resulting from improper use.

This device may be used only by persons with sufficient physical, sensorial, and intellectual abilities and having corresponding knowledge and experience. Other persons may use this device only if they are supervised or instructed by a person who is responsible for their safety.

Safety



DANGER!

Danger for children

Ensure that plastic bags, packaging, etc. are disposed of properly and are not within reach of babies and young children. Choking hazard!

Ensure that children do not detach any small parts (e.g. knobs or the like) from the unit. They could swallow the pieces and choke!

Never let children unattended use electrical devices.



DANGER!

Electric shock caused by short-circuit

Do not modify the mains cable or the plug. Failure to do so could result in electric shock/death or fire. If in doubt, seek advice from a registered electrician.



DANGER!

Electric shock caused by high voltages inside

Within the device there are areas where high voltages may be present. Never remove any covers.

There are no user-serviceable parts inside.

Do not use the device if covers, protectors or optical components are missing or damaged.



WARNING!

Eye damage caused by high light intensity

Never look directly into the light source.



WARNING!

Risk of epileptic shock

Strobe lighting can trigger seizures in photosensitive epilepsy. Sensitive persons should avoid looking at strobe lights.



WARNING!

Risk of burns

The surface of the device can become very hot during operation.

Do not touch the device with bare hands during operation, and after switching off wait for at least 15 minutes.



NOTICE!

Risk of fire

Do not block areas of ventilation. Do not install the device near any direct heat source. Keep the device away from naked flames.



NOTICE!

Power supply

Before connecting the device, ensure that the input voltage (AC outlet) matches the voltage rating of the device and that the AC outlet is protected by a residual current circuit breaker. Failure to do so could result in damage to the device and possibly injure the user.

Unplug the device before electrical storms occur and when it is unused for long periods of time to reduce the risk of electric shock or fire.

3 Features

Due to its sturdy and weather-proof housing made of die-cast aluminium, the device is especially suitable for outdoor use. With the very bright six-colour LEDs, it is particularly suitable for professional lighting tasks.

Special features of the device:

- 12 × six-colour LEDs (RGBWAUV, each 10 W)
- Control via DMX and via buttons and display on the unit
- Built-in automatic show programmes
- Master / Slave operation
- Protection class IP65
- Sturdy double bracket for secure attachment to trusses or firm footing on the ground
- Connections for power supply and DMX control by means of
 - LED Typhoon PAR Outdoor 12x10 (item no. 386284): permanently connected cables with splash-proof screwable and lockable plugs and couplings
 - LED Typhoon True PAR 12x10 Outdoor (item no. 420255): splash-proof screwable and lockable plugs and couplings
- Mains power adapter with safety plug included
- Rugged die-cast aluminium housing
- Pressure compensation element (prevents condensation inside the device)

Information about protection class IP65

Equipment with protection class IP65 are dust-tight and completely protected against contact (first code number). They are also protected against splash water from any angle (second code digit). That is why this equipment can also be used outdoors. Event technology equipment is generally only designed for temporary use however (event lighting) and not for permanent use outdoors.

The specified protection class does not make a statement about the weather resistance of the equipment (resistance to changing ambient conditions as well as against the effects of sunlight and UV rays).

The seals and screw connections of the equipment must be checked regularly to ensure a fault-free operation. In cases of doubt, consult a specialist workshop in due time.

4 Installation

Unpack and carefully check that there is no transportation damage before using the unit. Keep the equipment packaging. To fully protect the device against vibration, dust and moisture during transportation or storage use the original packaging or your own packaging material suitable for transport or storage, respectively.

**WARNING!****Risk of injury caused by falling objects**

Make sure that the installation complies with the standards and rules that apply in your country. Always secure the device with a secondary safety attachment, such as a safety cable or a safety chain.

**NOTICE!****Risk of overheating**

Always ensure sufficient ventilation.

The ambient temperature must not exceed the limits stated in the chapter Technical Specifications of the User Manual.

**NOTICE!****Use of stands**

When mounting the device onto a stand, ensure that the stand is in a safe and stable position and that the weight of the device does not exceed the maximum permissible load capacity of the stand.

**NOTICE!****Possible data transmission errors**

For error-free operation make use of dedicated DMX cables and do not use ordinary microphone cables.

Never connect the DMX input or output to audio devices such as mixers or amplifiers.

**NOTICE!****Possible damage due to moisture**

Moisture entering into open connectors (plugs and couplers) of DMX or power cords can cause short circuits.

Close unused connectors with end caps intended for this purpose (www.thomann.de).

Mounting options

You can install the unit in hanging or standing position. When in use, the device must always be attached to a solid surface or an approved truss. Use the openings provided on the two-piece bracket for attaching.

Always work from a stable platform whenever installing, moving or servicing the unit. In doing so, the area underneath the unit must be cordoned off.

The safety cable must be attached to the bracket (with item no. 386284) or to the safety eyelet (item no. 420255).



Please note that this device must not be connected to a dimmer.

5 Starting up

Create all connections while the device is off. Use the shortest possible high-quality cables for all connections. Take care when running the cables to prevent tripping hazards.

Connections in DMX mode

Connect the DMX input of the device to the DMX output of a DMX controller or another DMX device. Connect the output of the first DMX device to the input of the second one, and so on to form a daisy chain. Always ensure that the output of the last DMX device in the daisy chain is terminated with a resistor ($110\ \Omega$, $\frac{1}{4}\text{ W}$).

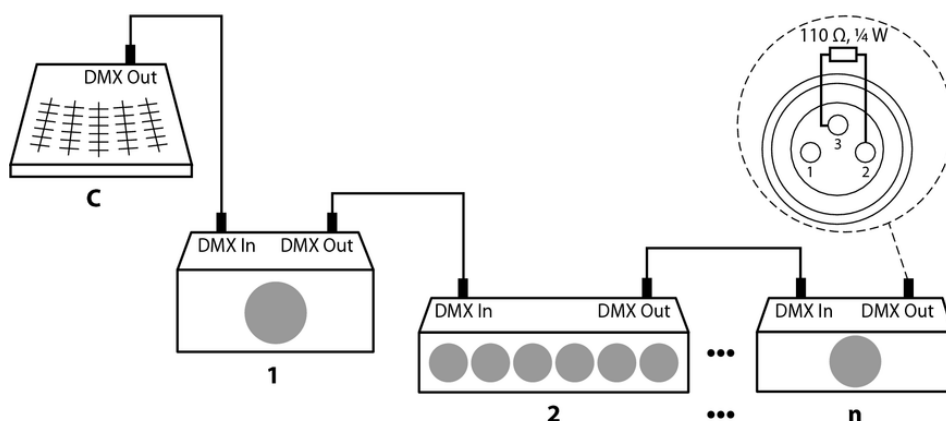

Connections in master/slave mode

When you configure a group of devices in master/slave mode, the first unit will control the other units for an automatic, sound-activated, synchronized show. This function is ideal when you want to start a show immediately. Connect the DMX output of the master device to the DMX input of the first slave device. Then connect the DMX output of the first slave device to the DMX input of the second slave device and so on.

6 Connections and controls

LED Typhoon PAR Outdoor 12x10 (item no. 386284)

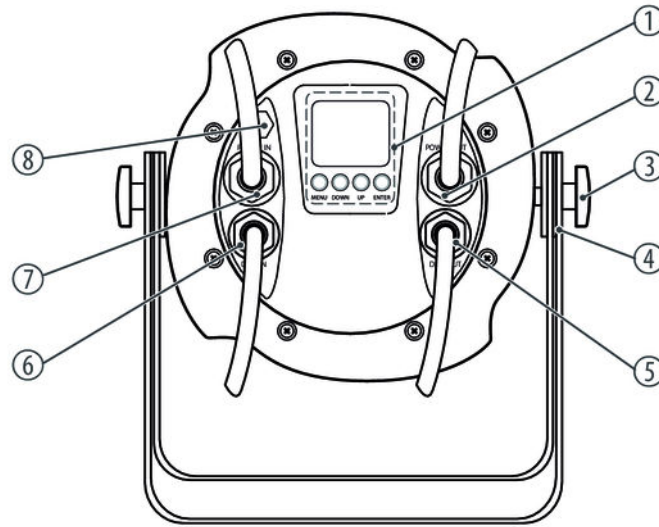

1 Display and keypad

The header displays the current operating mode, for example 'DMX' or 'SLAVE'. The dot-shaped DMX indicator lights green when a DMX signal is received and red when transmission is interrupted. The display shows the current device temperature top right. If the maximum permissible temperature is exceeded, the text appears in yellow.

In the middle of the display are selected menus and set values.

In the status bar at the bottom of the display, the message on the key lock appears. 'Key lock open' means that the key lock function is off. 'Key lock closed' means that the key lock function is on.

[MENU]

Activates the main menu and toggles between menu items.

[DOWN]

Decreases the displayed value by one.

[UP]

Increases the displayed value by one.

[ENTER]

Selects an option of the respective operating mode.

2 [POWER OUT]

Connection supply voltage outgoing (Power Twist IP65)

3 Bracket adjustment knobs

4 Two-piece bracket for hanging or installation and for securing the safety cable

5	<i>[DMX OUT]</i> DMX output
6	<i>[DMX IN]</i> DMX input
7	<i>[POWER IN]</i> Connection supply voltage incoming (Power Twist IP65)
8	Pressure compensation element

LED Typhoon True PAR 12x10 Outdoor (item no. 420255)

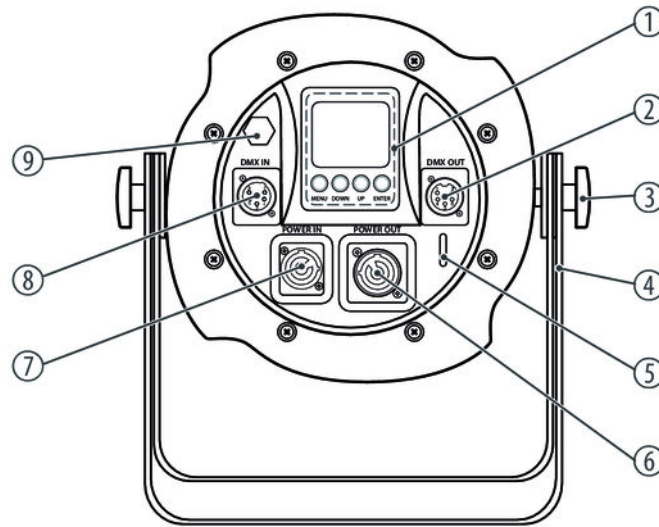

1 Display and keypad

The header displays the current operating mode, for example 'DMX' or 'SLAVE'. The dot-shaped DMX indicator lights green when a DMX signal is received and red when transmission is interrupted. The display shows the current device temperature top right. If the maximum permissible temperature is exceeded, the text appears in yellow.

In the middle of the display are selected menus and set values.

In the status bar at the bottom of the display, the message on the key lock appears. 'Key lock open' means that the key lock function is off. 'Key lock closed' means that the key lock function is on.

[MENU]

Activates the main menu and toggles between menu items.

[DOWN]

Decreases the displayed value by one.

[UP]

Increases the displayed value by one.

[ENTER]

Selects an option of the respective operating mode.

2 [DMX OUT]

DMX output, designed as 5-pin XLR chassis-mounted coupling

3 Bracket adjustment knobs

4 Two-piece bracket for hanging or floor setup

5 Safety cable eyelet.

6	<i>[POWER OUT]</i> Connection supply voltage outgoing (Power Twist IP65)
7	<i>[POWER IN]</i> Connection supply voltage incoming (Power Twist IP65)
8	<i>[DMX IN]</i> DMX input, designed as 5-pin XLR chassis-mounted plug
9	Pressure compensation element

7 Operating

7.1 Starting the device

Connect the device to the power supply to start operation. After a few seconds, the display indicates that a reset is in progress. The device is then ready for use. The display shows the operating mode that was selected when the unit was last powered off.

7.2 Main menu

Press *[ENTER]* to activate the main menu. Use the buttons *[UP]* or *[DOWN]* to select a submenu. When the display shows the desired submenu, press *[ENTER]* to open it. To close the main menu, press *[MODE]*.

All previously made settings are retained even when you disconnect the device from the power grid. To restart with default values, use the 'RESET' function.

The following table shows the setting options.

Main menu	Menu level 2	Menu level 3	Menu level 4
	Meaning		
'DMX'	DMX mode selection and DMX address setting		
	'CHANNEL 03'	3-channel DMX mode	
	'CHANNEL 06'	6-channel DMX mode	
	'CHANNEL 08'	08-channel DMX mode	
	'CHANNEL 10'	10-channel DMX mode	
	'CHANNEL 13'	13-channel DMX mode	
	'ADDRESS 001' ... 'ADDRESS 512'	Setting the DMX address	
'RUN MODE'	'DMX'	Operating mode 'DMX'	
	'SLAVE'	Operating mode 'Slave'	
'SET UP'	'ID number'	Setting an individual device ID. This allows groups of devices with the same DMX address to be controlled individually via DMX channel 13.	
		'OFF'	No ID assigned
		'1' ... '66'	Individual device ID
	'Display Led'	Automatic display shutdown when not in use	
		'ON'	Enabled
		'OFF'	Disabled

Main menu	Menu level 2	Menu level 3	Menu level 4
	Meaning		
	'Key locks'	Key lock	
		'OFF'	Off
		'ON'	Enabled To unlock the keys, press successively [ENTER], [DOWN], [UP], [DOWN], [UP] and [ENTER].
	'Max temp'	Maximum temperature whose exceeding is to be reported on the display	
		'002' ... '120'	Temperature in °C
	'Dimmer RED'	'0' ... '255'	Maximum intensity red (0 % to 100 %)
	'Dimmer GREEN'	'0' ... '255'	Maximum intensity green (0 % to 100 %)
	'Dimmer BLUE'	'0' ... '255'	Maximum intensity blue (0 % to 100 %)
	'Dimmer WHITE'	'0' ... '255'	Maximum intensity white (0 % to 100 %)
	'Dimmer AMB'	'0' ... '255'	Maximum intensity amber (0 % to 100 %)
	'Dimmer UV'	'0' ... '255'	Maximum intensity UV (0 % to 100 %)
	'Dimmer ALL'	'0' ... '255'	Maximum overall brightness (0 % to 100 %)
'INFORMATION'	'Software Vx.y.z'	Show firmware version of the device	
	'Hardware Hx.y.z'	Show hardware version of the device	
	'Fix times xh ym'	Operating hours display	
'AUTO'	Preprogrammed automatic show		
	'SPEED'	'0' ... '31'	
	'AUTO MODE'	'01' ... '21'	Selecting a preprogrammed automatic show
'CUSTOMER'	Self-created automatic show		
	'CUSTOM MODE'	'01' ... '11'	Selecting a self-created automatic show
'CAL WHITE'	White balance		
	'WHITE1' ... 'WHITE11'	Selection of white tone to be set	
	'RED'	'0' ... '255'	Amount red (0 % to 100 %)
	'GREEN'	'0' ... '255'	Amount green (0 % to 100 %)
	'BLUE'	'0' ... '255'	Amount blue (0 % to 100 %)
	'WHITE'	'0' ... '255'	Amount white (0 % to 100 %)
	'AMB'	'0' ... '255'	Amount amber (0 % to 100 %)
	'UV'	'0' ... '255'	Amount UV (0 % to 100 %)
'STAT COLOR'	Static colour		
	'STAT RED'	'0' ... '255'	Amount red (0 % to 100 %)

Main menu	Menu level 2	Menu level 3	Menu level 4	
	Meaning			
	'STAT GREEN'	'0' ... '255'	Amount green (0 % to 100 %)	
	'STAT BLUE'	'0' ... '255'	Amount blue (0 % to 100 %)	
	'STAT WHITE'	'0' ... '255'	Amount white (0 % to 100 %)	
	'STAT AMB'	'0' ... '255'	Amount amber (0 % to 100 %)	
	'STAT UV'	'0' ... '255'	Amount UV (0 % to 100 %)	
	'SELET COLOR'	'01' ... '70'	Selecting a pre-defined colour	
	'STAT STROB'	'01' ... '70'	Stroboscope effect with increasing speed	
'EDIT'	Defining self-created automatic shows			
	'PRO1' ... 'PRO11'	Selection of the show to be defined.		
		'SC 01' ... 'SC 32'	Selection of the scene as part of the show to be defined. Complete the definition of each scene by pressing [ENTER] for about 5 seconds.	
		'RED'	'0' ... '255'	Amount red (0 % to 100 %)
		'GREEN'	'0' ... '255'	Amount green (0 % to 100 %)
		'BLUE'	'0' ... '255'	Amount blue (0 % to 100 %)
		'WHITE'	'0' ... '255'	Amount white (0 % to 100 %)
		'AMB'	'0' ... '255'	Amount amber (0 % to 100 %)
		'UV'	'0' ... '255'	Amount UV (0 % to 100 %)
		'FADE'	'00' ... '31'	Fade effect
		'FLASH'	'00' ... '50'	Flash effect
		'STRO'	'00' ... '31'	Strobe effect
		'TIME'	'00' ... '100'	Duration of scene
'UPLOAD'	Distribution of self-created automatic shows from the master to slaves. Connect the devices configured as slaves to the master and press [ENTER] to transmit the data.			
'RESET'	Reset to factory defaults. Press [ENTER] to start the reset.			

7.3 Menu overview

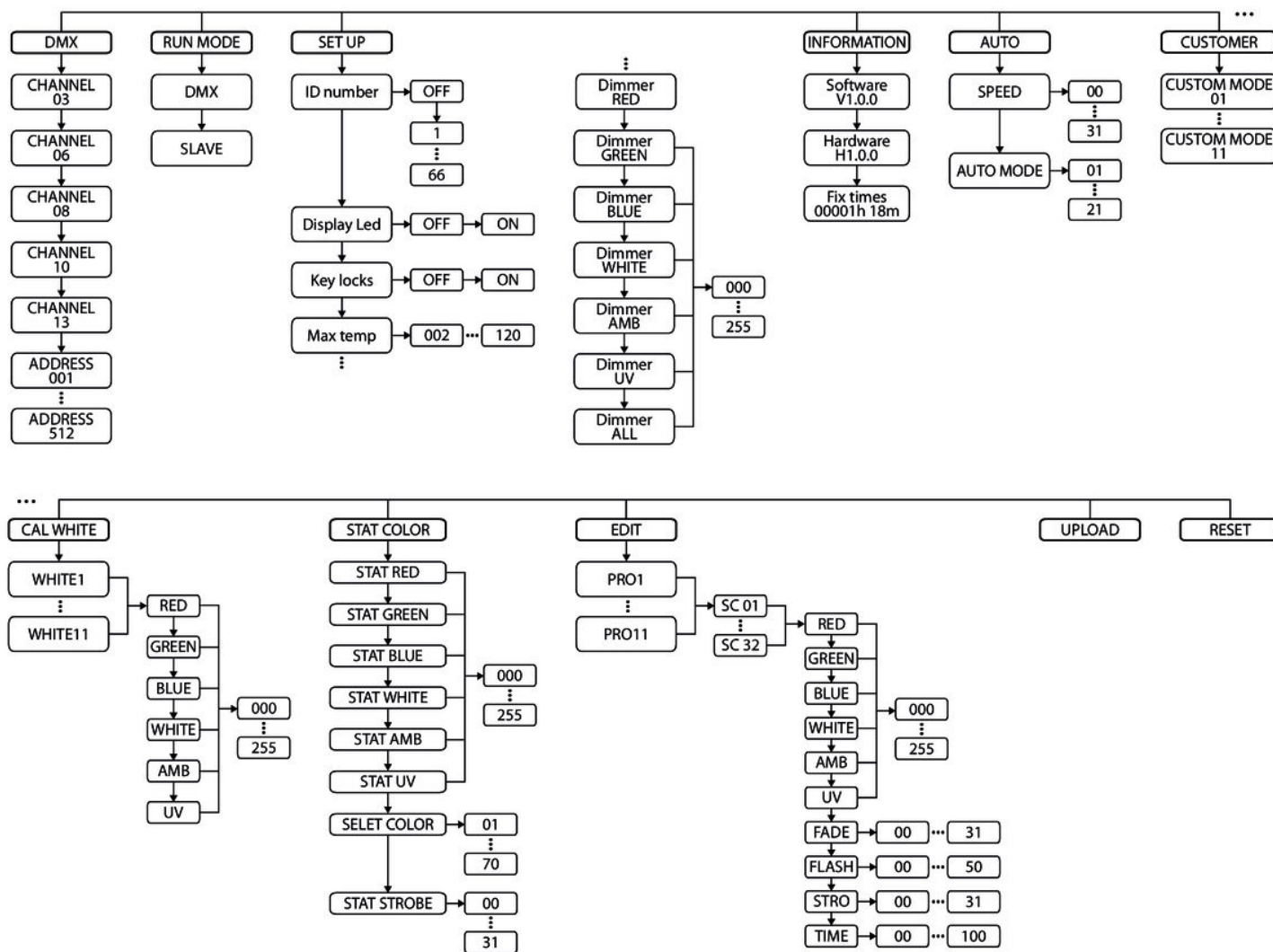

7.4 Functions in 3-channel DMX mode

Channel	Value	Function
1	0...255	Colour hue
2	0...255	Saturation (0 % to 100 %)
3	0...255	Brightness (0 % to 100 %)

7.5 Functions in 6-channel DMX mode

Channel	Value	Function
1	0...255	Intensity red (0 % to 100 %)
2	0...255	Intensity green (0 % to 100 %)
3	0...255	Intensity blue (0 % to 100 %)
4	0...255	Intensity white (0 % to 100 %)
5	0...255	Intensity amber (0 % to 100 %)
6	0...255	Intensity UV (0 % to 100 %)

7.6 Functions in 8-channel DMX mode

Channel	Value	Function
1	0...255	Brightness (0 % to 100 %)
2	0...255	Intensity red (0 % to 100 %)
3	0...255	Intensity green (0 % to 100 %)
4	0...255	Intensity blue (0 % to 100 %)
5	0...255	Intensity white (0 % to 100 %)
6	0...255	Intensity amber (0 % to 100 %)
7	0...255	Intensity UV (0 % to 100 %)
8	Dimmer curves with afterglow effect	
	0...49	Standard
	50...99	Dimmer mode 1 (slight afterglow)
	100...149	Dimmer mode 2
	150...199	Dimmer mode 3
	200...255	Dimmer mode 4 (strong afterglow)

7.7 Functions in 10-channel DMX mode

Channel	Value	Function
1	0...255	Brightness (0 % to 100 %)
2	0...255	Intensity red (0 % to 100 %)

Channel	Value	Function
3	0...255	Intensity green (0 % to 100 %)
4	0...255	Intensity blue (0 % to 100 %)
5	0...255	Intensity white (0 % to 100 %)
6	0...255	Intensity amber (0 % to 100 %)
7	0...255	Intensity UV (0 % to 100 %)
8	Dimmer curves with afterglow effect	
	0...49	Standard
	50...99	Dimmer mode 1 (slight afterglow)
	100...149	Dimmer mode 2
	150...199	Dimmer mode 3
	200...255	Dimmer mode 4 (strong afterglow)
9	Colour selection	
	0...19	None
	20...23	Red
	24...27	Green
	28...31	Blue
	32...35	Yellow
	36...39	Cyan
	40...43	Magenta
	44...47	White
	48...51	Orange
	52...55	Pink
	56...59	Purple
	60...63	Aquamarine
	64...67	Sky-blue
	68...71	Mint white 1
	72...75	Soft pink
	76...79	Light blue
	80...83	Mint white 2
	84...87	Bright pink
	88...91	Yellow 2
92...95	Straw	

Channel	Value	Function
	96...99	RGB white
	100...103	Light pink
	104...107	Dark pink
	108...111	Magenta 2
	112...115	Turquoise
	116...119	Medium teal
	120...123	Blue green
	124...127	Bright pink
	128...131	Medium blue
	132...135	Golden amber
	136...139	Deep golden amber
	140...143	Bright lavender
	144...147	Apricot
	148...151	Dark lavender
	152...155	Chocolate
	156...159	Simple blue
	160...163	Surprise pink
	164...167	Scarlet
	168...171	Surprise peach
	172...175	Dirty white 1
	176...179	English pink
	180...183	Mauve
	184...187	Beaming blue
	188...191	Alice blue
	192...195	Indigo rosé
	196...199	Urban blue
	200...203	Cold blue
	204...207	Light salmon-coloured
	208...211	Dirty white 2
	212...215	Cherry rosé
	216...219	Flesh-coloured
	220...223	Skeleton Exotic Sangria

Channel	Value	Function
	224...255	Beaming rosé
9	Colour macros	
	0...6	No function
	7...255	Colour macros
10	Strobe effect	
	0...8	Open, no stroboscope effect
	9...255	Stroboscope effect, increasing speed

7.8 Functions in 13-channel DMX mode

Channel	Value	Function
1	0...255	Brightness (0 % to 100 %)
2	0...255	Intensity red (0 % to 100 %)
3	0...255	Intensity green (0 % to 100 %)
4	0...255	Intensity blue (0 % to 100 %)
5	0...255	Intensity white (0 % to 100 %)
6	0...255	Intensity amber (0 % to 100 %)
7	0...255	Intensity UV (0 % to 100 %)
8	Automatic colour transition	
	0...10	No function
	11...90	Colour macro 1...8
	91...100	Pulse effect green / red
	101...110	Pulse effect blue / red
	111...120	Pulse effect blue / green
	121...130	Pulse effect yellow / blue
	131...140	Pulse effect light blue / red
	141...150	Pulse effect green / pink
	151...160	Colour change mint / yellow / magenta
	161...170	Colour change blue / red / magenta
	171...180	Colour change shades of blue
	181...190	Pulse effect UV
	191...200	RGBW 100 %

Channel	Value	Function
	201...205	White 1
	206...210	White 2
	211...215	White 3
	216...220	White 4
	221...225	White 5
	226...230	White 6
	231...235	White 7
	236...240	White 8
	241...245	White 9
	246...250	White 10
	251...255	White 11
9	0...255	Running speed, if channel 10 = 9...255
	0...8	Standard
	9...255	Strobe effect with increasing speed
10	Automatic show	
	0...8	Standard
	9...10	Colour change RGBWA/UV
	11...20	Colour change with 22 colours
	21...30	Ramp effect up / down
	31...40	Fade programme with 22 colours
	41...50	Multi-colour strobe effect with six colours
	51...60	Colour change with 24 colours
	61...70	Colour change with 27 colours
	71...80	Colour fade programme with pastel colours
	81...90	Multi-colour strobe effect with 24 colours
	91...100	Self-created automatic show 1
	101...110	Self-created automatic show 2
	111...120	Self-created automatic show 3
	121...130	Self-created automatic show 4
	131...140	Self-created automatic show 5
	141...150	Self-created automatic show 6
151...160	Self-created automatic show 7	

Channel	Value	Function
	161...170	Self-created automatic show 8
	171...180	Self-created automatic show 9
	181...190	Self-created automatic show 10
	200...255	Self-created automatic show 11
11	0...255	Running speed, if channel 10 = 9...255
12	Dimmer curves with afterglow effect	
	0...49	Standard
	50...99	Dimmer mode 1 (slight afterglow)
	100...149	Dimmer mode 2
	150...199	Dimmer mode 3
	200...255	Dimmer mode 4 (strong afterglow)
13	ID assignment for devices with the same DMX address according to the following table. If an ID is set on the device, it only reacts if this ID is selected with channel 13.	

Value	Meaning	Value	Meaning	Value	Meaning	Value	Meaning
0...9	All IDs	170...179	ID 17	223	ID 34	240	ID 51
10...19	ID 1	180...189	ID 18	224	ID 35	241	ID 52
20...29	ID 2	190...199	ID 19	225	ID 36	242	ID 53
30...39	ID 3	200...209	ID 20	226	ID 37	243	ID 54
40...49	ID 4	210	ID 21	227	ID 38	244	ID 55
50...59	ID 5	211	ID 22	228	ID 39	245	ID 56
60...69	ID 6	212	ID 23	229	ID 40	246	ID 57
70...79	ID 7	213	ID 24	230	ID 41	247	ID 58
80...89	ID 8	214	ID 25	231	ID 42	248	ID 59
90...99	ID 9	215	ID 26	232	ID 43	249	ID 60
100...109	ID 10	216	ID 27	233	ID 44	250	ID 61
110...119	ID 11	217	ID 28	234	ID 45	251	ID 62
120...129	ID 12	218	ID 29	235	ID 46	252	ID 63
130...139	ID 13	219	ID 30	236	ID 47	253	ID 64
140...149	ID 14	220	ID 31	237	ID 48	254	ID 65
150...159	ID 15	221	ID 32	238	ID 49	255	ID 66
160...169	ID 16	222	ID 33	239	ID 50		

8 Technical specifications

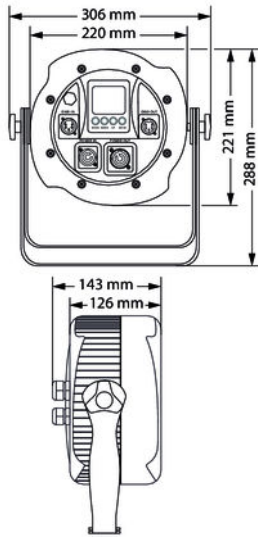

LEDs	12 × six-colour LEDs (RGBWAUV, each 10 W)
Beam angle	15 °
Number of DMX channels	3, 6, 8, 10 or 13, depending on operating mode
Operating supply voltage	100 – 240 V ~ 50/60 Hz
Power consumption	120 W
Protection class	IP65
Dimensions (W × H × D)	305 mm × 143 mm × 288 mm (15.35in. × 15.55in. × 5.31in.)
Weight	4.54 kg

9 Plug and connection assignment

Introduction

This chapter will help you select the right cables and plugs to connect your valuable equipment so that a perfect light experience is guaranteed.

Please take our tips, because especially in 'Sound & Light' caution is indicated: Even if a plug fits into a socket, the result of an incorrect connection may be a destroyed DMX controller, a short circuit or 'just' a not working light show!

DMX connections



The unit offers a 3-pin XLR socket for DMX output and a 3-pin XLR plug for DMX input. Please refer to the drawing and table below for the pin assignment of a suitable XLR plug.

Pin	Configuration
1	Ground, shielding
2	Signal inverted (DMX-, 'cold')
3	Signal (DMX+, 'hot')

DMX connections



A five-pin XLR socket serves as DMX output, a five-pin XLR plug serves as DMX input. The drawing below and the table show the pin assignment of a matching coupling.

Pin	Assignment
1	Ground (shielding)
2	Signal inverted (DMX-, 'cold')
3	Signal (DMX+, 'hot')
4	unused / second connection (DMX-)
5	unused / second connection (DMX+)

10 Troubleshooting



NOTICE!

Possible data transmission errors

For error-free operation make use of dedicated DMX cables and do not use ordinary microphone cables.

Never connect the DMX input or output to audio devices such as mixers or amplifiers.

In the following we list a few common problems that may occur during operation. We give you some suggestions for easy troubleshooting:

Symptom	Remedy
The unit does not work, no light.	Check the mains connection and the fuse.
No response to the DMX controller.	1. Check the DMX ports and cables for proper connection.
	2. Check the address settings and the DMX polarity.
	3. Try using another DMX controller.
	4. Check to see if the DMX cables run near or alongside to high voltage cables that may cause damage or interference to DMX interface circuits.

If the procedures recommended above do not succeed, please contact our Service Center. You can find the contact information at www.thomann.de.

11 Cleaning

Optical lenses

Clean the optical lenses, that are accessible from the outside, regularly in order to optimize the light output. The frequency of cleaning depends on the operating environment: wet, smoky or particularly dirty surroundings can cause more accumulation of dirt on the optics of the device.

- Clean with a soft cloth using our lamp and lens cleaner (item no. 280122).
- Always dry the parts carefully.

12 Protecting the environment

Disposal of the packaging material



For the transport and protective packaging, environmentally friendly materials have been chosen that can be supplied to normal recycling.

Ensure that plastic bags, packaging, etc. are properly disposed of.

Do not just dispose of these materials with your normal household waste, but make sure that they are collected for recycling. Please follow the notes and markings on the packaging.

Disposal of your old device



This product is subject to the European Waste Electrical and Electronic Equipment Directive (WEEE) in its currently valid version. Do not dispose with your normal household waste.

Dispose of this device through an approved waste disposal firm or through your local waste facility. When discarding the device, comply with the rules and regulations that apply in your country. If in doubt, consult your local waste disposal facility.

