



ignition

Romeo 650/1000
Fresnel/PC

theatre spotlight

Musikhaus Thomann
Thomann GmbH
Hans-Thomann-Straße 1
96138 Burgebrach
Germany
Telephone: +49 (0) 9546 9223-0
E-mail: info@thomann.de
Internet: www.thomann.de

09.08.2017, ID: 391663

Table of contents

1	General information	4
	1.1 Further information.....	5
	1.2 Notational conventions.....	6
	1.3 Symbols and signal words.....	6
2	Safety instructions	9
3	Features	14
4	Installation	15
5	Connections and controls	17
6	Maintenance	19
	6.1 Installing / replacing the illuminant.....	19
	6.2 Changing the lens.....	23
7	Technical specifications	26
8	Cleaning	27
9	Protecting the environment	28

1 General information

This manual contains important instructions for the safe operation of the unit. Read and follow the safety instructions and all other instructions. Keep the manual for future reference. Make sure that it is available to all those using the device. If you sell the unit please make sure that the buyer also receives this manual.

Our products are subject to a process of continuous development. Thus, they are subject to change.

1.1 Further information

On our website (www.thomann.de) you will find lots of further information and details on the following points:

Download	This manual is also available as PDF file for you to download.
Keyword search	Use the search function in the electronic version to find the topics of interest for you quickly.
Online guides	Our online guides provide detailed information on technical basics and terms.
Personal consultation	For personal consultation please contact our technical hotline.
Service	If you have any problems with the device the customer service will gladly assist you.

1.2 Notational conventions

This manual uses the following notational conventions:

Instructions



The individual steps of an instruction are numbered consecutively. The result of a step is indented and highlighted by an arrow.



Example:

1. ▶ Switch on the device.
2. ▶ Press *[Auto]*.
 - ⇒ Automatic operation is started.
3. ▶ Switch off the device.

1.3 Symbols and signal words

In this section you will find an overview of the meaning of symbols and signal words that are used in this manual.

Signal word	Meaning
DANGER!	This combination of symbol and signal word indicates an immediate dangerous situation that will result in death or serious injury if it is not avoided.
WARNING!	This combination of symbol and signal word indicates a possible dangerous situation that can result in death or serious injury if it is not avoided.
NOTICE!	This combination of symbol and signal word indicates a possible dangerous situation that can result in material and environmental damage if it is not avoided.
Warning signs	Type of danger
	Warning – high-voltage.
	Warning – hot surface.

Warning signs	Type of danger
 A yellow triangular warning sign with a black border. Inside the triangle, a black silhouette shows a rectangular load suspended from a hook by a chain.	Warning – suspended load.
 A yellow triangular warning sign with a black border. Inside the triangle, a large black exclamation mark is centered.	Warning – danger zone.

2 Safety instructions

Intended use

This device is intended to be used as an illumination effect. The device is designed for professional use and is not suitable for use in households. Use the device only as described in this user manual. Any other use or use under other operating conditions is considered to be improper and may result in personal injury or property damage. No liability will be assumed for damages resulting from improper use.

This device may be used only by persons with sufficient physical, sensorial, and intellectual abilities and having corresponding knowledge and experience. Other persons may use this device only if they are supervised or instructed by a person who is responsible for their safety.

Safety



DANGER!

Danger for children

Ensure that plastic bags, packaging, etc. are disposed of properly and are not within reach of babies and young children. Choking hazard!

Ensure that children do not detach any small parts (e.g. knobs or the like) from the unit. They could swallow the pieces and choke!

Never let children unattended use electrical devices.



DANGER!

Electric shock caused by high voltages inside

Within the device there are areas where high voltages may be present.

Completely disconnect the device from the power supply before you open or remove covers. Mount all covers and attach them firmly before connecting the device again.

Do not use the device if covers, protectors or optical components are missing or damaged.



DANGER!

Electric shock caused by short-circuit

Do not modify the mains cable or the plug. Failure to do so could result in electric shock/death or fire. If in doubt, seek advice from a registered electrician.



WARNING!

Eye damage caused by high light intensity

Never look directly into the light source.



WARNING!

Risk of burns at the surface and inside of the device

The surface and the inner parts of the device can become very hot during operation.

After switching off the device wait for at least 15 minutes before you start any maintenance activities.



NOTICE!

Risk of fire

Do not block areas of ventilation. Do not install the device near any direct heat source. Keep the device away from naked flames.



NOTICE!

Operating conditions

This device has been designed for indoor use only. To prevent damage, never expose the device to any liquid or moisture. Avoid direct sunlight, heavy dirt, and strong vibrations.



NOTICE!

Power supply

Before connecting the device, ensure that the input voltage (AC outlet) matches the voltage rating of the device and that the AC outlet is protected by a residual current circuit breaker. Failure to do so could result in damage to the device and possibly injure the user.

Unplug the device before electrical storms occur and when it is unused for long periods of time to reduce the risk of electric shock or fire.

3 Features

The professional theatre spotlight is suitable for almost all applications, for example in clubs, bars, small stages and theatres. It is characterized by compact dimensions, solid construction and enormous performance.

Special features of the device:

- Suitable for halogen stage lamps with GX9.5 socket, 230 V, maximum power consumption 1000 W (not included)
- Manually adjustable large zoom range
- Robust metal housing with colour filter frame holder and bracket
- Colour filter frame, PC lens and barn door included

4 Installation

Unpack and carefully check that there is no transportation damage before using the unit. Keep the equipment packaging. To fully protect the device against vibration, dust and moisture during transportation or storage use the original packaging or your own packaging material suitable for transport or storage, respectively.

You can install the device on a ceiling or on a stand. An adjustable mounting bracket with locking screws is included in the package.



WARNING!

Risk of injury caused by falling objects

Make sure that the installation complies with the standards and rules that apply in your country. Always secure the device with a secondary safety attachment, such as a safety cable or a safety chain.



NOTICE!

Fire and overheating hazard

The distance between the light source and flammable materials must be greater than 12 m. The distance to non-flammable materials must be greater than 2 m.

Always ensure sufficient ventilation.

The ambient temperature must always be below 40 °C (104 °F).



NOTICE!

Use of stands

When mounting the device onto a stand, ensure that the stand is in a safe and stable position and that the weight of the device does not exceed the maximum permissible load capacity of the stand.

5 Connections and controls

Rear panel

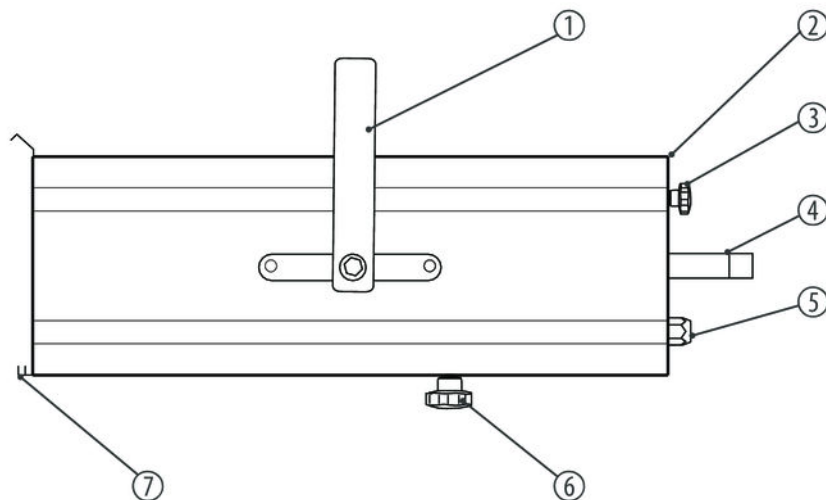

Romeo 650/1000 Fresnel/PC

1	Bracket for floor placement or hanging.
2	Safety cable eyelet.
3	Star knob screw for the upper housing cover.
4	Guiding bracket.
5	Power cord.
6	Locking screw for focus. Loosen the screw and position the slider for optimum illumination.
7	Holder for barn doors, colour films or filters.

6 Maintenance

6.1 Installing / replacing the illuminant

**DANGER!****Electric shock caused by high voltages inside**

Within the device there are areas where high voltages may be present.

Completely disconnect the device from the power supply before you open or remove covers. Mount all covers and attach them firmly before connecting the device again.

Do not use the device if covers, protectors or optical components are missing or damaged.



WARNING!

Risk of burns at the surface and inside of the device

The surface and the inner parts of the device can become very hot during operation.

After switching off the device wait for at least 15 minutes before you start any maintenance activities.



NOTICE!

Possible damages due to dirt or finger prints

Due to the high temperatures, even smallest pieces of dirt on the bulb can destroy the lamp when it is turned on.

Do not touch the lamp directly with your fingers. Use clean gloves or a clean lint-free tissue.

**NOTICE!****Possible damages due to wrong type of lamp**

Any attempt to use the device with a lamp other than those specified in this manual can result in severe damages to the device.

Only use a lamp of the specified type.

Notes on the illuminant

The device may only be operated using an illuminant with an GX9.5 socket, maximum power consumption 1000 W, for use in stage and theatre area. Observe the safety instructions of the illuminant manufacturer.

Procedure

- 1.** ➤ Make sure that the device is turned off, disconnected from the mains and completely cooled down.
- 2.** ➤ Move the device in a horizontal position.
- 3.** ➤ Carefully unscrew the star knob screw on the rear panel completely. Slide the upper housing cover all the way back.

- 4.** ▶ Carefully pull the old illuminant out of the socket on the bottom of the unit. Be careful not to touch the hollow mirror behind the socket.
- 5.** ▶ Insert the new illuminant firmly into the socket. Check the secure fit.
- 6.** ▶ Slide the upper housing cover all the way to the front.
Tighten the star knob screw completely.
- 7.** ▶ Check that the upper housing cover is properly seated.

6.2 Changing the lens

**DANGER!****Electric shock caused by high voltages inside**

Within the device there are areas where high voltages may be present.

Completely disconnect the device from the power supply before you open or remove covers. Mount all covers and attach them firmly before connecting the device again.

Do not use the device if covers, protectors or optical components are missing or damaged.



WARNING!

Risk of burns at the surface and inside of the device

The surface and the inner parts of the device can become very hot during operation.

After switching off the device wait for at least 15 minutes before you start any maintenance activities.

Procedure

- 1.** ➤ Make sure that the device is turned off, disconnected from the mains and completely cooled down.
- 2.** ➤ Move the device in a horizontal position.
- 3.** ➤ Carefully unscrew the star knob screw on the rear panel completely. Slide the upper housing cover all the way back.
- 4.** ➤ Loosen the knurled screw that connects the fixing ring to the housing. A long nose pliers may be handy on this.
- 5.** ➤ Remove the fixing ring backwards. The lens can then be removed.
- 6.** ➤ Insert the new lens. Pay attention to the retaining pin on the right side of the housing.

- 7.** ▶ Reattach the retaining ring in its original position and tighten the knurled screw. Check the lens for firm fit.
- 8.** ▶ Slide the upper housing cover all the way to the front.
Tighten the star knob screw completely.
- 9.** ▶ Check that the upper housing cover is properly seated.

7 Technical specifications

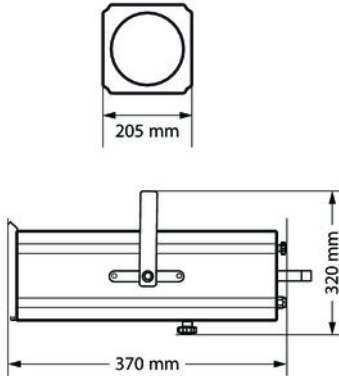

Illuminant	Halogen stage lamps with GX9.5 socket, 230 V, maximum power consumption 1000 W, like item # 129143 (650 W) or item # 146984 (1000 W)
Zoom range	10°...60°
Power consumption	depends on the inserted illuminant
Operating supply voltage	230 V ~ 50 Hz
Dimensions (W × H × D)	205 × 320 × 370 mm

8 Cleaning

Optical lenses

Clean the optical lenses, that are accessible from the outside, regularly in order to optimize the light output. The frequency of cleaning depends on the operating environment: wet, smoky or particularly dirty surroundings can cause more accumulation of dirt on the optics of the device.

- Clean with a soft cloth using our lamp and lens cleaner (item no. 280122).
- Always dry the parts carefully.

Fan grids

The fan grids of the device must be cleaned on a regular basis to remove dust and dirt. Before cleaning, switch off the device and disconnect AC-powered devices from the mains. Use a lint-free damp cloth for cleaning. Never use solvents or alcohol for cleaning.

9 Protecting the environment

Disposal of the packaging material



For the transport and protective packaging, environmentally friendly materials have been chosen that can be supplied to normal recycling.

Ensure that plastic bags, packaging, etc. are properly disposed of.

Do not just dispose of these materials with your normal household waste, but make sure that they are collected for recycling. Please follow the notes and markings on the packaging.

Disposal of your old device



This product is subject to the European Waste Electrical and Electronic Equipment Directive (WEEE). Do not dispose with your normal household waste.

Dispose of this device through an approved waste disposal firm or through your local waste facility. When discarding the device, comply with the rules and regulations that apply in your country. If in doubt, consult your local waste disposal facility.

Romeo 650/1000 Fresnel/PC



Musikhaus Thomann · Hans-Thomann-Straße 1 · 96138 Burgebrach · Germany · www.thomann.de