

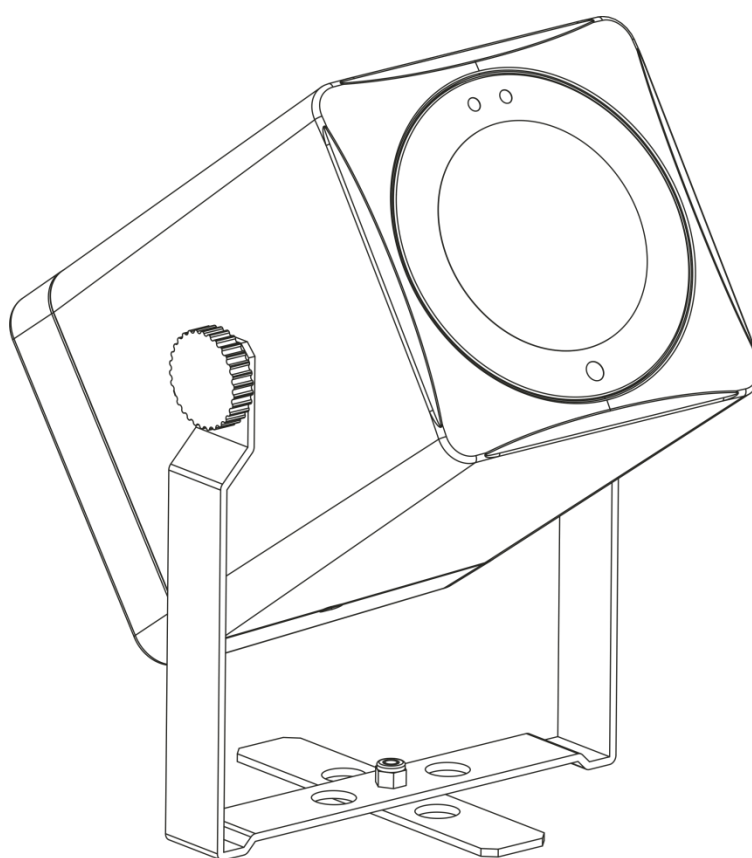

MANUAL



ENGLISH

Eventspot 60 Q7

V1

Ordercode: 42726

Table of contents

Warning	3
Safety Instructions	3
Operating Determinations	5
Rigging	5
Connection with the mains	6
Return Procedure	6
Claims	6
Description of the device	7
Optional accessories	7
Overview	9
Installation	9
Set Up and Operation	9
Charging the built-in battery	9
Control Modes	10
One Eventspot 60 Q7 (Manual mode)	10
One Eventspot 60 Q7 (Built-in Programs)	10
Multiple Eventspots 60 Q7 (Wireless DMX Control)	10
Disconnect from the Wireless DMX signal transmitter	11
Data Cabling	11
Control Panel	12
DMX Control Mode	12
DMX Addressing	12
Menu overview	13
Main Menu Options	14
1. Static Colors	14
2. DMX Address	15
3. Built-in programs	15
4. Personality (DMX channel modes)	15
5. Edit Mode	16
6. Settings	16
6.1. Reset	16
6.2. Color	17
6.3. Dimmer	17
6.4. DMX Error	17
7. Safety lock	17
8. Calibration	18
8.1. White color calibration	18
8.2. RGB to W calibration	18
8.3. UC calibration	18
9. Software information	19
10. Reset wireless	19
Optional remote control	20
Static colors	21
Built-in programs	21
DMX Channels	22
7 Channels HSIC	22
10 Channels SSP	23
13 Channels TOUR	24
20 Channels TR16	26
Maintenance	28

Troubleshooting28
 No Light28
 No Response to DMX.....28

Product Specifications30

Dimensions.....31

Notes32

Warning



**For your own safety, please read this user manual carefully
before your initial start-up!**



Unpacking Instructions

Immediately upon receiving this product, carefully unpack the carton and check the contents to ensure that all parts are present, and have been received in good condition. Notify the dealer immediately and retain packing material for inspection if any parts appear to be damaged from shipping or the carton itself shows signs of mishandling. Save the carton and all packing materials. In the event that the fixture must be returned to the factory, it is important that the fixture be returned in the original factory box and packing.

Your shipment includes:

- Showtec Eventspot 60 Q7
- Adapter charger DC 24V (1,75 m)
- User manual

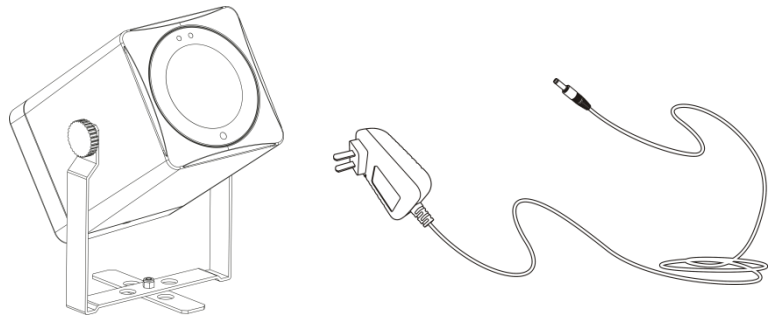

LED Expected Lifespan

LEDs gradually decline in brightness over time. HEAT is the dominant factor that leads to the acceleration of this decline. Packaged in clusters, LEDs exhibit higher operating temperatures than in ideal or singular optimum conditions. For this reason when all color LEDs are used at their fullest intensity, life of the LEDs is significantly reduced. If improving the lifespan is of higher priority, place care in providing for lower operational temperatures. This may include climatic-environmental and the reduction of overall projection intensity



CAUTION!

**Keep this device away from rain and moisture!
Unplug mains lead before opening the housing!**



Safety Instructions

Every person involved with the installation, operation and maintenance of this device has to:

- be qualified
- follow the instructions of this manual



**CAUTION! Be careful with your operations.
With a dangerous voltage you can suffer
a dangerous electric shock when touching the wires!**



Before your initial start-up, please make sure that there is no damage caused by transportation. Should there be any, consult your dealer and do not use the device.

To maintain perfect condition and to ensure a safe operation, it is absolutely necessary for the user to follow the safety instructions and warning notes written in this manual.

Please consider that damages caused by manual modifications to the device are not subject to warranty.

This device contains no user-serviceable parts. Refer servicing to qualified technicians only.

IMPORTANT:

The manufacturer will not accept liability for any resulting damages caused by the non-observance of this manual or any unauthorized modification to the device.

- Never let the power cord come into contact with other cables! Handle the power cord and all connections with the mains with particular caution!
- Never remove warning or informative labels from the unit.
- Never use anything to cover the ground contact.
- Never place any material over the lens.
- Never look directly into the light source.
- Never leave any cables lying around.
- Do not insert objects into air vents.
- Do not connect this device to a dimmerpack.
- Do not switch the device on and off in short intervals, as this would reduce the device's lifespan.
- Do not touch the device's housing bare-handed during its operation. Allow the fixture to cool for at least 5 minutes before handling.
- Do not shake the device. Avoid brute force when installing or operating the device.
- Only use device indoor, avoid contact with water or other liquids.
- Only operate the fixture after having checked that the housing is firmly closed and all screws are tightly fastened.
- Only operate the device after having familiarized with its functions.
- Avoid flames and do not put close to flammable liquids or gases.
- Always keep case closed while operating.
- Always allow free air space of at least 50 cm around the unit for ventilation.
- Always disconnect power from the mains, when device is not used or before cleaning! Only handle the power cord by the plug. Never pull out the plug by tugging the power cord.
- Make sure that the device is not exposed to extreme heat, moisture or dust.
- Make sure that the available voltage is not higher than stated on the rear panel.
- Make sure that the power cord is never crimped or damaged. Check the device and the power cord from time to time.
- If the lens is obviously damaged, it has to be replaced to prevent its functions from being impaired, due to cracks or deep scratches.
- If device was dropped or struck, disconnect mains power supply immediately. Have a qualified engineer inspect for safety before operating.
- If the device has been exposed to drastic temperature fluctuation (e.g. after transportation), do not switch it on immediately. The arising condensation water might damage your device. Leave the device switched off until it has reached room temperature.
- If your Showtec device fails to work properly, discontinue use immediately. Pack the unit securely (preferably in the original packing material), and return it to your Showtec dealer for service.
- For adult use only. Device must be installed out of reach of children. Never leave the unit running unattended.
- Never attempt to bypass the thermostatic switch or fuses.
- For replacement, use fuses of same type and rating only.
- The user is responsible for correct positioning and operating of the Showtec Eventspot 60 Q7. The manufacturer will not accept liability for damages caused by the misuse or incorrect installation of this device.
- This device falls under protection class I. Therefore it is essential to connect the yellow/green conductor to earth.
- Repairs, servicing and electrical connection must be carried out by a qualified technician.
- **WARRANTY:** Till one year after date of purchase.



CAUTION! Eyedamages!!!
Avoid looking directly into the lightsource!!!
(meant especially for epileptics)!!!



Operating Determinations

- This device is not designed for permanent operation. Regular operation breaks will ensure that the device will serve you for a long time without defects.
- The minimum distance between light-output and the illuminated surface must be bigger than 0,5 meter.
- The maximum ambient temperature $t_a = 45^{\circ}\text{C}$ must never be exceeded.
- The relative humidity must not exceed 50 % with an ambient temperature of 45°C .
- If this device is operated in any other way than the one described in this manual, the product may suffer damages and the warranty becomes void.
- Any other operation may lead to dangers like short-circuit, burns, electric shock, crash etc.

You endanger your own safety and the safety of others!

Rigging

Please follow the European and national guidelines concerning rigging, trussing and all other safety issues.

Do not attempt the installation yourself !

Always let the installation be carried out by an authorized dealer !

Procedure:

- If the Eventspot is lowered from the ceiling or high joists, professional trussing systems have to be used.
- Use a clamp to mount the Eventspot, with the mounting bracket, to the trussing system.
- The Eventspot must never be fixed swinging freely in the room.
- The installation must always be secured with a safety attachment, e.g. an appropriate safety net or safety cable.
- When rigging, derigging or servicing the Eventspot, always make sure, that the area below the installation site is secured and that there are not any unauthorized people around.

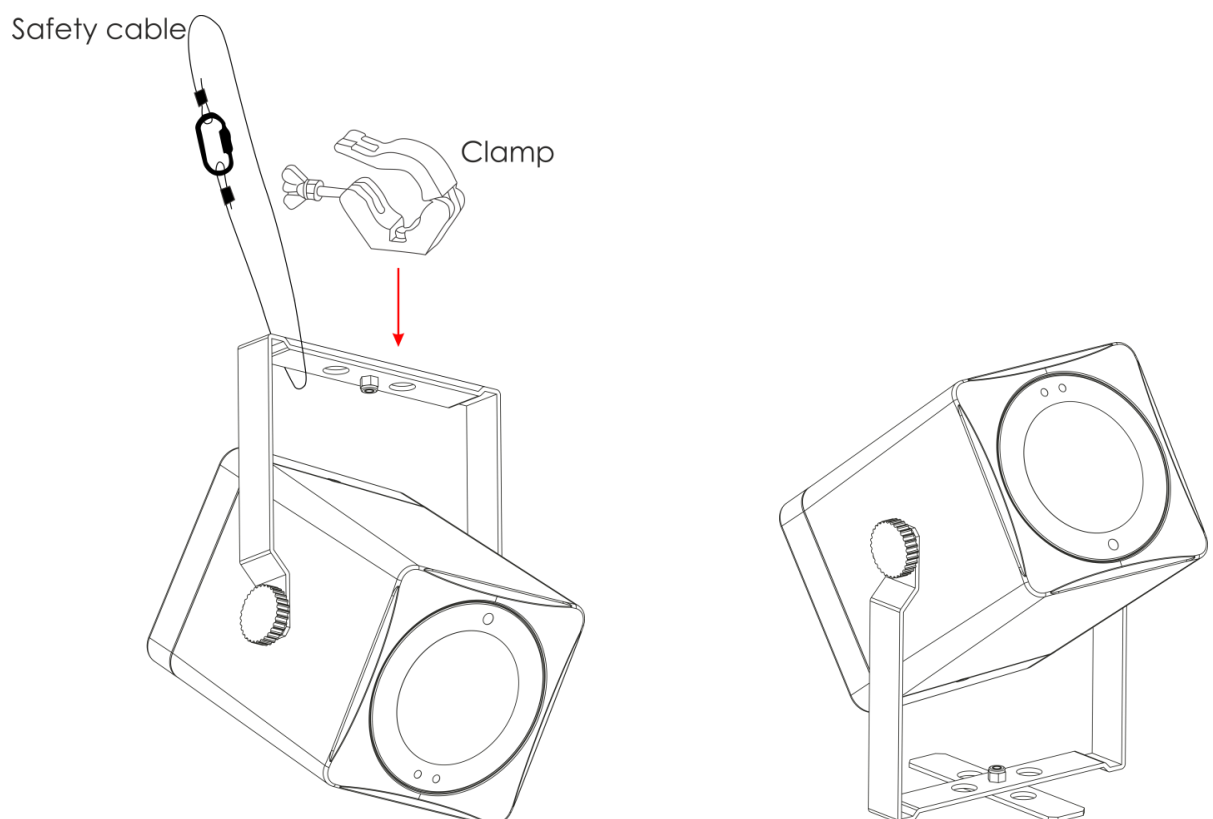

The Eventspot 60 Q7 can be placed on a flat stage floor or mounted to any kind of truss with a clamp.

Connection with the mains

Connect the device to the mains with the power plug.
Always check if the right color cable is connected to the right place.

International	EU Cable	UK Cable	US Cable	Pin
L	BROWN	RED	YELLOW/COPPER	PHASE
N	BLUE	BLACK	SILVER	NEUTRAL
	YELLOW/GREEN	GREEN	GREEN	PROTECTIVE GROUND

Make sure that the device is always connected properly to the earth!

Improper installation can cause serious damage to people and property!

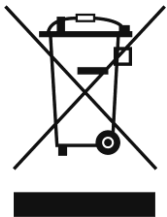

⚠ Return Procedure ⚠

Returned merchandise must be sent prepaid and in the original packing, call tags will not be issued. Package must be clearly labeled with a Return Authorization Number (RMA number). Products returned without an RMA number will be refused. Highlite will not accept the returned goods or any responsibility. Call Highlite 0031-455667723 or mail aftersales@highlite.nl and request an RMA prior to shipping the fixture. Be prepared to provide the model number, serial number and a brief description of the cause of the return. Be sure to properly pack fixture as any shipping damage resulting from inadequate packaging is the customer's responsibility. Highlite reserves the right to use its own discretion to repair or replace product(s). As a suggestion, proper UPS packing or double-boxing is always a safe method to use.

Note: If you are given an RMA number, please include the following information on a piece of paper inside the box:

- 01) Your name.
- 02) Your address.
- 03) Your phone number.
- 04) A brief description of the symptoms.

Claims

The client has the obligation to check the delivered goods immediately upon delivery for any shortcomings and/or visible defects, or perform this check after our announcement that the goods are at their disposal. Damage incurred in shipping is the responsibility of the shipper; therefore the damage must be reported to the carrier upon receipt of merchandise.

It is the customer's responsibility to notify and submit claims with the shipper in the event that the fixture is damaged due to shipping. Transportation damage has to be reported to us within one day after receipt of the delivery.

Any return shipment has to be made post-paid at all times. Return shipments must be accompanied with a letter defining the reason for return shipment. Non-prepaid return shipments will be refused, unless agreed otherwise in writing.

Complaints against us must be made known in writing or by fax within 10 working days after receipt of the invoice. After this period, complaints will not be handled anymore.

Complaints will only be considered if the client has so far complied with all parts of the agreement, regardless of the agreement of which the obligation is resulting.

Description of the device

Features

The Eventspot 60 Q7 is the smallest member of the Eventspot series. Although it has a small size its features are great. The Eventspot 60 Q7 is equipped with one 7-in-1 LED offering an extremely wide color palette.

- RGBWA-UV-Lime colormixing
- Wide zoom range
- WDMX
- Compact size
- Input Voltage: 24V DC
- Power consumption at full output: 20W
- LED: 7 LED (RGBWA-UV-Lime)
- Operating time at Full On: 6 hours at full RGBWA-UV-Lime on
- Charging time: 6 hours
- Control: On-board: LCD-Display
- Control Protocol: DMX512 via wireless DMX512
- Control Personality: HSIC, SSP, TOUR and TR16 (7CH/ 10CH/ 13CH/ 20CH)
- Output (4,5°): 1400 Lux @ 2 meter
- Output (45°): 68 Lux @ 2 meter
- Maximum projection distance: 4m (depending on zoom angle)
- Dimmer: 0-100%
- Strobe: 0-25Hz
- Adjustable zoom angle: 4,5° to 45°
- Field angle: 8° to 55°
- Housing: Black plastic extrusion
- IP rating: IP54
- Fixture Connection: 24V DC connection
- Cooling: Convection
- Operation Temperature: -20°C ~45°C
- Dimensions: 138 x 102 x 190 mm (LxWxH) (incl. bracket)
- Weight: 1,14 Kg

Note: Knowledge of DMX is required to fully utilize this unit.

Optional accessories

42728 Remote control for Eventspot 60 Q7

42729 Flightcase for Eventspot 60 Q7

[50231](#) Wireless DMX Transceiver

[50236](#) BlackBox F-1 G4 Transceiver

DMX Channel Summary

HSIC	Channel	Description
	1	Master Dimmer
	2	Hue (color variations)
	3	Hue (color variations) fine
	4	Red color saturation
	5	Color macro's white
	6	Special strobe
	7	Dimmer speed

SSP	Channel	Description
	1	Master dimmer
	2	Red
	3	Green
	4	Blue
	5	White
	6	Amber
	7	Lime
	8	UV
	9	Special strobe
	10	Dimmer speed

Tour	Channel	Description
	1	Master Dimmer
	2	Red
	3	Green
	4	Blue
	5	White
	6	Amber
	7	Lime
	8	UV
	9	Color macros
	10	Special strobe
	11	Auto program
	12	Auto program speed
	13	Dimmer speed

TR16	Channel	Description
	1	Master Dimmer
	2	Red
	3	Red fine
	4	Green
	5	Green fine
	6	Blue
	7	Blue fine
	8	White
	9	White fine
	10	Amber
	11	Amber fine
	12	Lime
	13	Lime fine
	14	UV
	15	UV fine
	16	Color macros
	17	Special strobe
	18	Auto program
	19	Auto program speed
	20	Dimmer speed

Overview

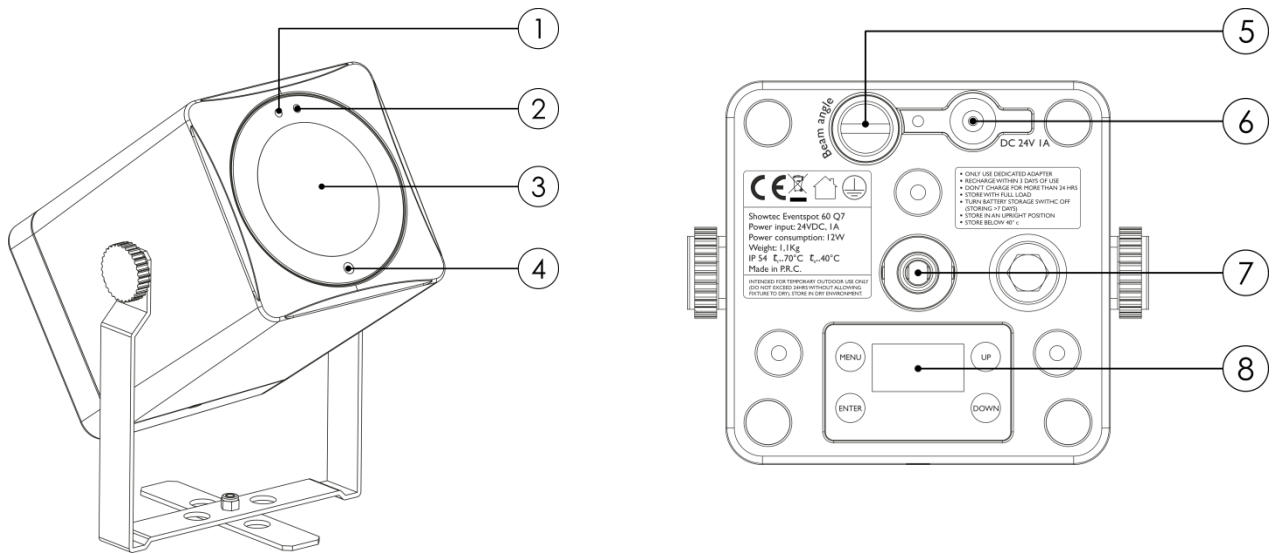

Fig. 01

- 01) WDMX indicator LED
- 02) Power indicator LED
- 03) 1x 7-in-1 LED (RGBWA-UV-Lime)
- 04) Infra red sensor
- 05) Adjustable zoom angle screw
- 06) Input adapter charger 24V DC 1A
- 07) Battery charger socket
- 08) LCD display + control buttons

Installation

Remove all packing materials from the Eventspot 60 Q7. Check that all foam and plastic padding is removed. Connect all cables.

Do not supply power before the whole system is set up and connected properly.

Always disconnect from electric mains power supply before cleaning or servicing.

Damages caused by non-observance are not subject to warranty.

Set Up and Operation

Before plugging the unit in, always make sure that the power supply matches the product specification voltage. Do not attempt to operate a 120V specification product on 230V power, or vice versa.

Charging the built-in battery

- 01) In order to charge the battery, you need either the included charger for Eventspot 60 Q7 or the optional flightcase with built-in chargers (42729).
- 02) Turn off the power.
- 03) Connect the Eventspot with the included charger.
- 04) While the battery is charging, the **red** LED at the front will light up.
- 05) When the battery is fully charged, the **green** LED at the front will light up.

Important!

- Do not charge for more than 24 hours.
- Recharge within 3 days of use.
- When charging your Eventspot in the flightcase, make sure that the flightcase is open.
- Store with full load.
- **Turn off the power with the menu button** at the bottom, when storing for more than 7 days.
- Store in an upright position.

Control Modes

There are 3 modes: Manual mode (stand alone)
 Built-in programs (stand alone)
 Wireless DMX (W-DMX)

One Eventspot 60 Q7 (Manual mode)

01) When the Eventspot 60 Q7 is not connected by Wireless DMX, it functions as a stand-alone device.
 See page 14 for more information about the manual mode.

One Eventspot 60 Q7 (Built-in Programs)

01) When the Eventspot 60 Q7 is not connected by Wireless DMX, it functions as a stand-alone device.
 See page 15 for more information about the built-in programs.

Multiple Eventspots 60 Q7 (Wireless DMX Control)

- 01) Place the Eventspots at the desired position (see next page for maximum distance).
- 02) When the WDMX indicator LED (green) is blinking, the fixture is searching for a connection.
- 03) Connect the transmitter with multiple Eventspots. In order to create a Wireless match, please check the manual of your wireless signal transmitter.
- 04) When there is a connection, the indicator LED from the Eventspot will display green.
- 05) Use a DMX-cable to link the transmitter with a suitable lightcontroller.

Setup example wireless DMX

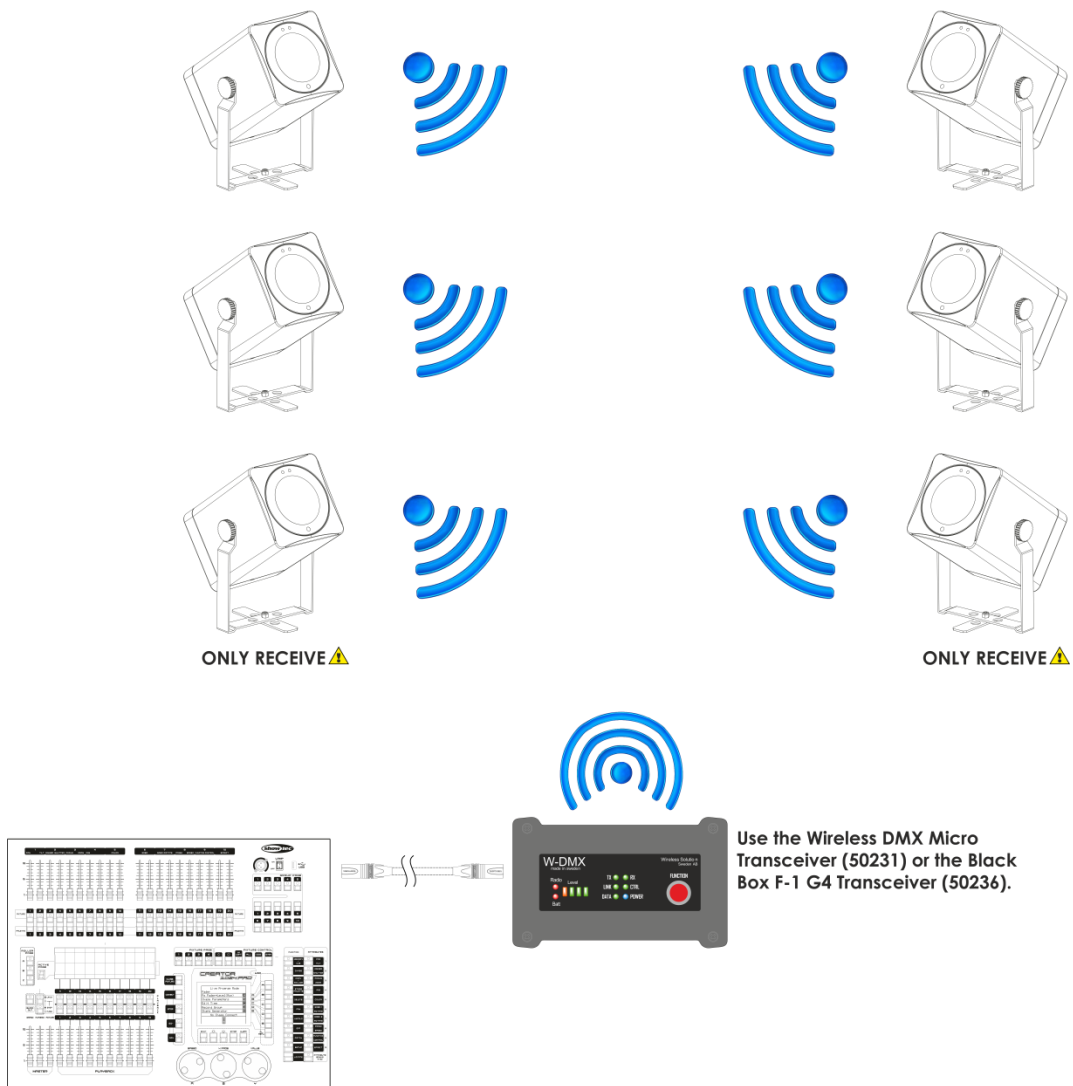

Fig. 02

Sweden 2.4GHz Wireless communication module

Communication distance:	depending on the transmitting power or transmitter module
Test conditions:	W-DMX TRx Transmitter module, 2dBi Antenna, transmitting power 20dBm (100mW)
Range indoor:	60m (approx. through three concrete walls)
Range outdoor:	250m

Wireless DMX connection

The wireless receiving module "Pico G4 Receiver, 2.4GHz", provided by Swedish WIRELESS SOLUTION, only has a 2.4 GHz wireless signal receiving function. In order to match the wireless signal, please use the Wireless DMX Micro Transmitter (**50231**) / Black Box F-1 G4 MK2 (**50236**) by WIRELESS SOLUTION. To control the status of the wireless communication, please look at the green LED indicator light on the front of the fixture.

Wi-fi Problems:

- 01) No emitter/sender matching.
The LED Indicator dims for a long period of time.
- 02) Matching signal with one emitter, but loss of signal communication.
The LED Indicator light will light up for 100ms and then dim for 100ms; The LED will flicker quickly.
- 03) Communication with an emitter, but no DMX data.
The LED Indicator will light up for 900ms and then dim for 100ms; The LED will flicker slowly.

When the device is in the manual mode or built-in program mode, please ensure that the matching 2.4GHz wireless signal transmitter is OFF.



The Eventspot 60 Q7 is only a WDMX receiver and never a WDMX sender



The Eventspot 60 Q7 has a total of 4 DMX channel configurations, referred as **Personalities**. The 4 **Personalities** are HSIC, SSP, Tour and TR16. Each of the different personalities can be accessed from the control panel.

Disconnect from the Wireless DMX signal transmitter

The Eventspot 60 Q7 can be disconnected from the wireless DMX signal transmitter. You can reset the W-DMX in the main menu, see page 19 for more information.

Data Cabling

To link transmitters with lightcontrollers you must obtain data cables. You can purchase DAP Audio certified DMX cables directly from a dealer/distributor or construct your own cable. If you choose to create your own cable please use data-grade cables that can carry a high quality signal and are less prone to electromagnetic interference.

DAP Audio DMX Data Cables

- DAP Audio Basic microphone cable for allround use. bal. XLR/M 3-pin > XLR/F 3-pin. **Ordercode** FL01150 (1,5 m), FL013 (3 m), FL016 (6 m), FL0110 (10 m), FL0115 (15 m), FL0120 (20 m).
- DAP Audio X-type data cable XLR/M 3-pin > XLR/F 3-pin. **Ordercode** FLX0175 (0,75 m), FLX01150 (1,5 m), FLX013 (3 m), FLX016 (6 m), FLX0110 (10 m).
- DAP Audio cable for the demanding user with exceptional audio-qualities and connector made by Neutrik®. **Ordercode** FL71150 (1,5 m), FL713 (3 m), FL716 (6 m), FL7110 (10 m).
- DAP Audio cable for the demanding user with exceptional audio-qualities and connector made by Neutrik®. **Ordercode** FL7275 (0,75 m), FL72150 (1,5 m), FL723 (3 m), FL726 (6 m), FL7210 (10 m).
- DAP Audio 110 Ohm cable with digital signal transmission. **Ordercode** FL0975 (0,75 m), FL09150 (1,5 m), FL093 (3 m), FL096 (6 m), FL0910 (10 m), FL0915 (15 m), FL0920 (20 m).
- DAP Audio DMX adapter: 3-pin/5-pin. **Ordercode** FLA30.

Control Panel

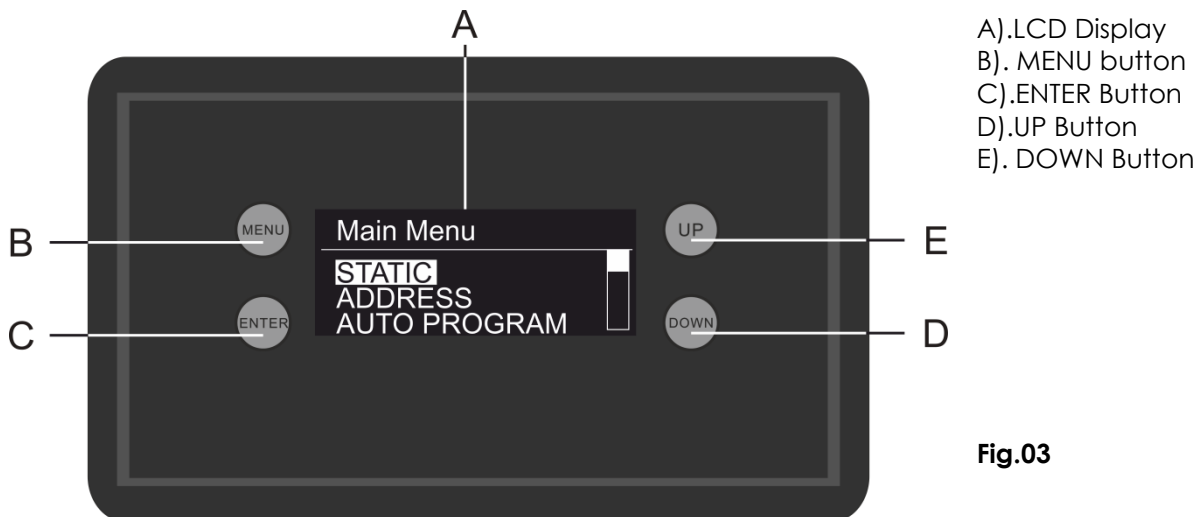

Fig.03

DMX Control Mode

The fixtures are individually addressed and connected to the W-DMX transmitter. The W-DMX transmitter is connected to the DMX controller. The fixtures respond to the DMX signal from the controller.

DMX Addressing

The control panel on the bottom of the fixture allows you to assign the DMX fixture address, which is the first channel from which the Eventspot will respond to the controller. Please note when you use the controller, the unit has up to **20** channels (in TR16 mode).

When using multiple Eventspots in **TR16 mode**, make sure you set the DMX addresses right. Therefore, the DMX address of the first Eventspot should be **1(001)**; the DMX address of the second Eventspot should be **1+20=21 (021)**; the DMX address of the third Eventspot should be **21+20=41 (041)**, etc. Please, be sure that you don't have any overlapping channels in order to control each Eventspot correctly. If two or more Eventspots are addressed similarly, they will work similarly.

Controlling: After having addressed all Eventspots, you may now start operating these via your lighting controller.

Note: After switching on, the Eventspot will automatically detect whether DMX 512 data is received or not. If not, the problem may be:

- The XLR cable from the controller is not connected with the input of the W-DMX transmitter.
- The controller is switched off or defective, the cable or connector is defective, or the signal wires are swapped in the input connector.

Display Off after 30 seconds

When no button is pressed for 30 seconds, the display will turn off.

To light up the display, you have to press one of the buttons: MENU, ENTER, UP or DOWN.

Once you have pressed the buttons, the display will light up.

Menu overview

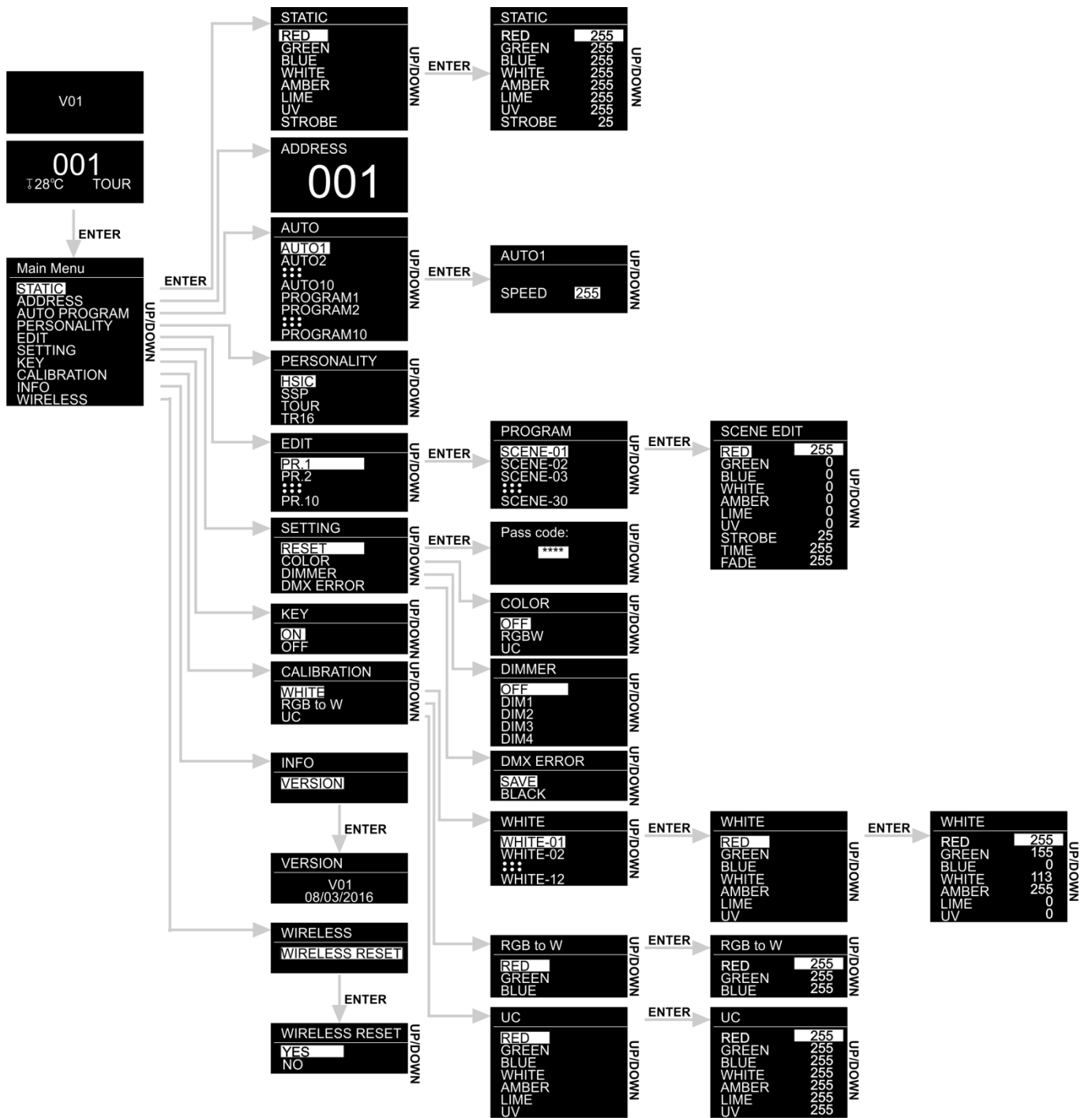

Main Menu Options

01) Upon start-up, the display will interchangeably show two screens:



02) Press the **ENTER** button to open the main menu. The display will show:

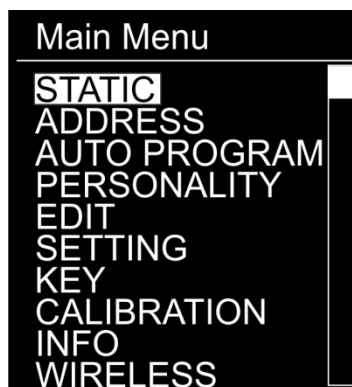

03) Press the **UP/DOWN** buttons to toggle between the 10 menus.

04) Press the **ENTER** button to open the desired menu.

05) Press the **MENU** button to return to the previous screen.

1. Static Colors

With this menu, you can set the static colors.

01) While in the main menu, press the **UP/DOWN** buttons to choose **STATIC**.

02) Press the **ENTER** button to open the menu. The display will show:



03) Press the **UP/DOWN** buttons to toggle between the static colors (RED, GREEN, BLUE, WHITE, AMBER, LIME AND UV) and STROBE.

04) Once you have chosen the desired color, press the **ENTER** button to enter the edit menu.

05) Press the **UP/DOWN** buttons to adjust the color intensity. The adjustment range is between 0-255, from dark to brightest.

06) Press the **ENTER** button to proceed to STROBE. Press the **UP/DOWN** buttons to increase/decrease the strobe frequency. The adjustment range is between 0-25, from OFF to high strobe frequency.

07) You can combine RED, GREEN, BLUE, WHITE, AMBER, LIME and UV to create an infinite range of colors (0-255).

2. DMX Address

With this menu you can set the device's DMX starting address.

- 01) While in the main menu, press the **UP/DOWN** buttons to choose **ADDRESS**.
- 02) Press the **ENTER** button to open the menu. The display will show:

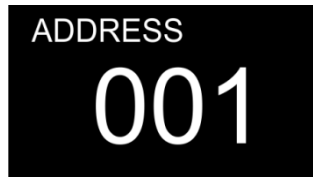

- 03) Press the **UP/DOWN** buttons to set the desired DMX address. The adjustment range is between 001-512.
- 04) The device will remember the DMX address after switching off.

3. Built-in programs

With this menu, you can choose a built-in program or custom program.

- 01) While in the main menu, press the **UP/DOWN** buttons to choose **AUTO**.
- 02) Press the **ENTER** button to open the menu. The display will show:



- 03) Press the **UP/DOWN** buttons to choose one of the 10 uneditable built-in programs (AUTO1-AUTO10) and 10 presets (PROGRAM1-PROGRAM10) which can be edited in Edit mode (see page 16).
- 04) If you have chosen one of the programs (AUTO1-AUTO10), press the **ENTER** button to proceed to the program speed settings.
- 05) Press the **UP/DOWN** buttons to set the program speed. The adjustment range is between 0-255, from slow to fast.
- 06) The device will now run the desired built-in program.
- 07) If you have chosen one of the custom programs (PROGRAM1-PROGRAM10), the device will immediately run the selected custom program.

4. Personality (DMX channel modes)

With this menu, you can set the desired DMX channel mode (personality).

- 01) While in the main menu, press the **UP/DOWN** buttons to choose **PERSONALITY**.
- 02) Press the **ENTER** button to open the menu. The display will show:

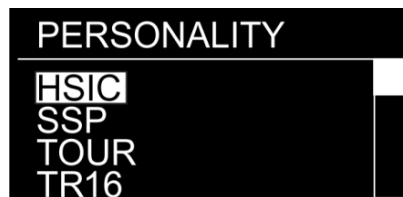

- 03) Press the **UP/DOWN** buttons to toggle between the following DMX channel modes:

HSIC:	7 channels	SSP:	10 channels
TOUR:	13 channels	TR16:	20 channels

5. Edit Mode

With this menu, you can create your own custom programs.

- 01) While in the main menu, press the **UP/DOWN** buttons to choose **EDIT**.
- 02) Press the **ENTER** button to open the menu. The display will show:

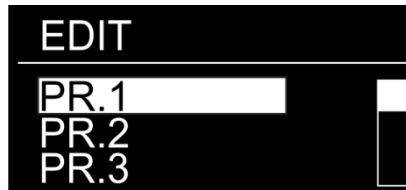

- 03) Press the **UP/DOWN** buttons to choose the desired custom program (PROGRAM1 – PROGRAM 10).
- 04) Each custom program has 30 scenes, which can be edited. Press the **ENTER** button to proceed the editing of the desired program (PROGRAM1 – PROGRAM 10).
- 05) Press the **UP/DOWN** buttons to select the desired scene (SCENE-01 - SCENE-30).
- 06) Press the **ENTER** button to enter the scene settings.
- 07) Press the **UP/DOWN** buttons to toggle between RED, GREEN, BLUE, WHITE, AMBER, LIME, UV, STROBE, TIME and FADE options.
- 08) If you have chosen RED, GREEN, BLUE, WHITE, AMBER, LIME OR UV press the **ENTER** button to open the menu.
- 09) Press the **UP/DOWN** buttons to increase/decrease the LED intensity. The adjustment range is between 0-255, from OFF to FULL ON.
- 10) If you have chosen STROBE, press the **ENTER** button to open the menu.
- 11) Press the **UP/DOWN** buttons to set the strobe frequency. The adjustment range is between 0-25, from OFF to high frequency.
- 12) If you have chosen TIME, press the **ENTER** button to open the menu.
- 13) Press the **UP/DOWN** buttons to set the duration of a scene. The adjustment range is between 0-255, from 0 to 255 seconds.
- 14) If you have chosen FADE, press the **ENTER** button to open the menu.
- 15) Press the **UP/DOWN** buttons to set the fade time between particular scenes. The adjustment range is between 0-255, from 0 to 255 seconds.

6. Settings

With this menu you can set the device's settings.

- 01) While in the main menu, press the **UP/DOWN** buttons to choose **SETTING**.
- 02) Press the **ENTER** button to open the menu.
- 03) Insert the **password** in order to access the menu. Press the buttons in the following order: **UP, DOWN, UP, DOWN** and press the **ENTER** button to confirm.
- 04) Press the **UP/DOWN** buttons to toggle between the following menus: Reset, Color, Dimmer and DMX Error. The display will show:



6.1. Reset

With this menu, you can reset the custom programs.

- 01) While in SETTING menu, press the **UP/DOWN** buttons to choose **RESET**.
- 02) Press the **ENTER** button to open the menu.
- 03) Insert the password in order to access the menu. Press the buttons in the following order: **UP, DOWN, UP, DOWN** and press the **ENTER** button to confirm.
- 04) When the process is finished, the display will show "**OK**". The custom programs have been reset to the factory default settings.

6.2. Color

With this menu, you can adjust the color calibration functions.

- 01) While in SETTING menu, press the **UP/DOWN** buttons to choose **COLOR**.
- 02) Press the **ENTER** button to open the menu.
- 03) Press the **UP/DOWN** buttons to toggle between the 3 options: RGBW, OFF or UC.
- 04) If you have chosen RGBW, then RGB to WHITE is active. This means RGB = 255, 255, 255. The displayed color is the one which you set in CALIBRATION > RGBW menu (8. Calibration, page 18).
- 05) If you have chosen OFF, the RGB values are not adjusted and the output is the most powerful.
- 06) If you have chosen UC, the RGB output is adjusted to a universal color which you can set in CALIBRATION > UC menu (8. Calibration, page 18). In this way, different Eventspot versions are color-balanced in order to match each other.

6.3. Dimmer

With this menu, you can adjust the dimmer speed.

- 01) While in SETTING menu, press the **UP/DOWN** buttons to choose **DIMMER**.
- 02) Press the **ENTER** button to open the menu.
- 03) Press the **UP/DOWN** buttons to choose one of the 4 dimmer speed options (DIM1-DIM4, from fast to slow) and OFF.
- 04) If you choose OFF, then RGBW and the master dimmer will be linear.

6.4. DMX Error

With this menu, you can determine the device's behaviour in case of a DMX signal error.

- 01) While in SETTING menu, press the **UP/DOWN** buttons to choose **DMX ERROR**.
- 02) Press the **ENTER** button to open the menu.
- 03) Press the **UP/DOWN** buttons to toggle between the 2 options: BLACK and SAVE.
- 04) If you have chosen BLACK, the Eventspot will blackout, in case of a DMX signal error.
- 05) If you have chosen SAVE, the Eventspot will fall back on the last working DMX signal, which will ensure undisrupted performance.

7. Safety lock

With this menu you can select whether the safety lock is active or not.

- 01) While in the main menu, press the **UP/DOWN** buttons to choose **KEY**.
- 02) Press the **ENTER** button to open the menu. The display will show:



- 03) Press the **UP/DOWN** buttons to toggle between ON and OFF.
- 04) If you have chosen ON and when the display turns off after remaining idle for 30 seconds, you will need to insert the password in order to access the main menu (press the buttons in the following order: **UP, DOWN, UP, DOWN** and press the **ENTER** button to confirm).
- 05) If you have chosen OFF, the main menu will remain unlocked.

8. Calibration

With this menu, you can calibrate the device's colors.

- 01) While in the main menu, press the **UP/DOWN** buttons to choose **CALIBRATION**.
- 02) Press the **ENTER** button to open the menu.
- 03) Insert the **password** in order to access the menu. Press the buttons in the following order: **UP, DOWN, UP, DOWN** and press the **ENTER** button to confirm. The display will show:



- 04) Press the **UP/DOWN** buttons to toggle between WHITE (white color calibration), RGBW (RGBW calibration) and UC (Universal Color correction).

8.1. White color calibration

With this menu you can adjust the temperature of the built-in white color presets.

- 01) If you have chosen WHITE, press the **ENTER** button to open the menu. The display will show:



- 02) Press the **UP/DOWN** buttons to choose one of the 12 white color presets: WHITE-01 – WHITE-12.
- 03) Once you have chosen the desired preset, press the **ENTER** button to open the submenu.
- 04) Press the **UP/DOWN** buttons to toggle between RED, GREEN, BLUE, WHITE, AMBER, LIME and UV.
- 05) Press the **ENTER** button to select a desired color.
- 06) Press the **UP/DOWN** buttons to increase/decrease the intensity of the chosen color. The adjustment range of each color is between 0-255, from OFF to FULL ON.
- 07) To toggle now between the colors you have to use the **ENTER** button or press the **MENU** button to return to the previous screen.

8.2. RGB to W calibration

With this menu you can adjust the temperature of the white color by means of RGB colors.

- 01) If you have chosen RGB to W, press the **ENTER** button to open the submenu.
- 02) Press the **UP/DOWN** buttons to toggle between RED, GREEN and BLUE.
- 03) Once you have chosen the desired color, press the **ENTER** button to edit.
- 04) Press the **UP/DOWN** buttons to set the color intensity. The adjustment range is between 0-255, from OFF to FULL ON.
- 05) To toggle now between the colors you have to use the **ENTER** button or press the **MENU** button to return to the previous screen.

8.3. UC calibration

With this menu you can adjust the universal color of the device.

- 01) If you have chosen UC, press the **ENTER** button to open the submenu.
- 02) Press the **UP/DOWN** buttons to toggle between RED, GREEN, BLUE, WHITE, AMBER, LIME and UV.
- 03) Once you have chosen the desired color, press the **ENTER** button to edit.
- 04) Press the **UP/DOWN** buttons to set the color intensity. The adjustment range is between 0-255, from OFF to FULL ON.
- 05) To toggle now between the colors you have to use the **ENTER** button or press the **MENU** button to return to the previous screen.

9. Software information

With this menu you can view the currently installed software version.

- 01) While in the main menu, press the **UP/DOWN** buttons to choose **INFO**.
- 02) Press the **ENTER** button to open the menu.
- 03) Press the **ENTER** button again to access the submenu.
- 04) You can now view the currently installed software version.



10. Reset wireless

With this menu you can reset the wireless connection with the transmitter.

- 01) While in the main menu, press the **UP/DOWN** buttons to choose **WIRELESS**.
- 02) Press the **ENTER** button to open the menu. The display will show:



- 03) Press the **ENTER** button again to access the submenu.
- 04) Press the **UP/DOWN** buttons to toggle between the 2 options: YES and NO.
- 05) If you choose YES you have to press the **ENTER** button to confirm.
- 06) The display will show "**RESETTING**".
- 07) After a few seconds the wireless link with the transmitter is interrupted.
- 08) The WDMX indicator LED (green) will blink.
- 09) Now you can use a different transmitter to make a wireless connection.

Optional remote control

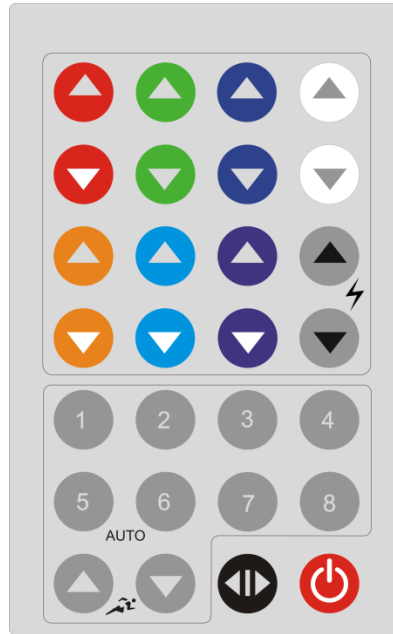





Button	Function	Description
	On / Off	Switch the device ON or OFF
	Dimmer	Master dimmer for RGBWA-UV-Lime
	Program Mode	Activate built-in program 1
	Program Mode	Activate built-in program 2
	Program Mode	Activate built-in program 3
	Program Mode	Activate built-in program 4
	Program Mode	Activate built-in program 5
	Program Mode	Activate built-in program 6
	Program Mode	Activate built-in program 7
	Program Mode	Activate built-in program 8
	Program speed	Increase/Decrease the program speed
	Red	Increase/Decrease the red LED intensity
	Green	Increase/Decrease the green LED intensity

	Blue	Increase/Decrease the blue LED intensity
		
	White	Increase/Decrease the white LED intensity
		
	Amber	Increase/Decrease the amber LED intensity
		
	Lime	Increase/Decrease the lime LED intensity
		
	UV	Increase/Decrease the UV LED intensity
		
	Strobe	Increase/Decrease the frequency of the strobe (0-25Hz)
		

Static colors

- 01) You can select pre-programmed static colors with the color buttons, see for more information the explanation above.
- 02) You can combine RED, GREEN, BLUE, WHITE, AMBER, LIME and UV to create an infinite range of colors.
- 03) With the strobe function you can create a terrific effect.

Built-in programs

- 01) With the numbers  to  you can activate a built-in program.
- 02) To regulate the speed of the desired program use the program speed buttons ( ).

DMX Channels

7 Channels HSIC

Channel 1 – Dimmer intensity maximum output

0-255 From dark to brightest 0-100%

Channel 2 – Hue (color variations) (CH1 and CH4 must be set between 001-255)

0-255 Hue from 0-100%

Channel 3 – Hue Fine (color variations) (CH1 and CH4 must be set between 001-255)

0-255 Hue Fine from 0-100%

Channel 4 – Red color saturation (CH1 must be set between 001-255)

0-255 Saturation from 0-100%

Channel 5 – Color Macros (CH1 must be set between 001-255)

0-10	No function
11-30	White 1: 2700K
31-50	White 2: 3000K
51-70	White 3: 3200K
71-90	White 4: 3500K
91-110	White 5: 4000K
111-130	White 6: 4200K
131-150	White 7: 4500K
151-170	White 8: 5600K
171-190	White 9: 6000K
191-210	White 10: 6500K
211-230	White 11: 7200K
231-255	White 12: 8000K

Channel 6 – Strobe (CH1 & CH2, CH3, or CH4 must be set between 001-255 & CH5 between 11-255)

0-9	No function
10-50	Strobe flash frequency, from slow to fast (0-25Hz)
51-100	No function
101-150	Pulse strobe, from slow to fast
151-200	No function
201-255	Random strobe, from slow to fast

Channel 7 – Dimmer speed

0-9	No function
10-29	Off (RGBW and Master dimmer linear)
30-69	DIM1 (fastest)
70-129	DIM2
130-189	DIM3
190-255	DIM4 (slowest)

10 Channels SSP

Channel 1 – Dimmer intensity

0-255 Gradual adjustment, from dark to brightest 0-100%

Channel 2 – Red dimmer intensity (CH1 must be set between 001-255)

0-255 Red from 0-100%

Channel 3 – Green dimmer intensity (CH1 must be set between 001-255)

0-255 Green from 0-100%

Channel 4 – Blue dimmer intensity (CH1 must be set between 001-255)

0-255 Blue from 0-100%

Channel 5 – White dimmer intensity (CH1 must be set between 001-255)

0-255 White from 0-100%

Channel 6 – Amber dimmer intensity (CH1 must be set between 001-255)

0-255 Amber from 0-100%

Channel 7 – Lime dimmer intensity (CH1 must be set between 001-255)

0-255 Lime from 0-100%

Channel 8 – UV dimmer intensity (CH1 must be set between 001-255)

0-255 UV from 0-100%

Channel 9 – Strobe (CH1 and CH2, CH3, CH4, CH5, CH6, CH7 or CH8 must be set between 001-255)

0-9	No function
10-50	Strobe flash frequency, from slow to fast (0-25Hz)
51-100	No function
101-150	Pulse strobe, from slow to fast
151-200	No function
201-255	Random strobe, from slow to fast

Channel 10 – Dimmer speed

0-9	No function
10-29	Off (RGBW and Master dimmer linear)
30-69	DIM1 (fastest)
70-129	DIM2
130-189	DIM3
190-255	DIM4 (slowest)

13 Channels TOUR

Channel 1 – Dimmer intensity

0-255 Gradual adjustment, from dark to brightest 0-100%

Channel 2 – Red dimmer intensity (CH1 must be set between 001-255)

0-255 Red from 0-100%

Channel 3 – Green dimmer intensity (CH1 must be set between 001-255)

0-255 Green from 0-100%

Channel 4 – Blue dimmer intensity (CH1 must be set between 001-255)

0-255 Blue from 0-100%

Channel 5 – White dimmer intensity (CH1 must be set between 001-255)

0-255 White from 0-100%

Channel 6 – Amber dimmer intensity (CH1 must be set between 001-255)

0-255 Amber from 0-100%

Channel 7 – Lime dimmer intensity (CH1 must be set between 001-255)

0-255 Lime from 0-100%

Channel 8 – UV dimmer intensity (CH1 must be set between 001-255)

0-255 UV from 0-100%

Channel 9 – Macros (CH1 must be set between 001-255)

0-10	No function
11-30	Red 100% / Green Up / Blue 0%
31-50	Red Down / Green 100% / Blue 0%
51-70	Red 0% / Green 100% / Blue Up
71-90	Red 0% / Green Down / Blue 100%
91-110	Red Up / Green 0% / Blue 100%
111-130	Red 100% / Green 0% / Blue Down
131-150	Red 100% / Green Up / Blue Up
151-170	Red Down / Green Down / Blue 100%
171-195	Red 100% / Green 100% / Blue 100% / White 100% / Amber 100% / Lime 100% / UV 100%
196-200	White 1: 2700K
201-205	White 2: 3000K
206-210	White 3: 3200K
211-215	White 4: 3500K
216-220	White 5: 4000K
221-225	White 6: 4200K
226-230	White 7: 4500K
231-235	White 8: 5600K
236-240	White 9: 6000K
241-245	White 10: 6500K
246-250	White 11: 7200K
251-255	White 12: 8000K

Channel 10 – Strobe

(CH1 & CH2, CH3, CH4, CH5, CH6, CH7, or CH8 must be set between 001-255 & CH9 between 11-255 )

0-9	No function
10-50	Strobe flash frequency, from slow to fast (0-25Hz)
51-100	No function
101-150	Pulse strobe, from slow to fast
151-200	No function
201-255	Random strobe, from slow to fast

Channel 11 – Auto program (CH1 must be set between 001-255 )

0-40	No function
41-50	AUTO01
51-60	AUTO02
61-70	AUTO03
71-80	AUTO04
81-90	AUTO05
91-100	AUTO06
101-110	AUTO07
111-120	AUTO08
121-130	AUTO09
131-140	AUTO10
141-150	PROGRAM1
151-160	PROGRAM2
161-170	PROGRAM3
171-180	PROGRAM4
181-190	PROGRAM5
191-200	PROGRAM6
201-210	PROGRAM7
211-220	PROGRAM8
221-230	PROGRAM9
231-255	PROGRAM10

Channel 12 – Auto speed (CH11 must be set between 41-140 )

0-255	Speed adjustment, from slow to fast
-------	-------------------------------------

Channel 13 – Dimmer speed

0-9	No function
10-29	Off (RGBW and Master dimmer linear)
30-69	DIM1 (fastest)
70-129	DIM2
130-189	DIM3
190-255	DIM4 (slowest)

20 Channels TR16**Channel 1 – Dimmer intensity**

0-255 Gradual adjustment, from dark to brightest 0-100%

Channel 2 – Red dimmer intensity (CH1 must be set between 001-255 )

0-255 Red from 0-100%

Channel 3 – Fine Red (CH1 and CH2 must be set between 001-255 )

0-255 Fine adjustment Red from 0-100%

Channel 4 – Green dimmer intensity (CH1 must be set between 001-255 )

0-255 Green from 0-100%

Channel 5 – Fine Green (CH1 and CH4 must be set between 001-255 )

0-255 Fine adjustment Green from 0-100%

Channel 6 – Blue dimmer intensity (CH1 must be set between 001-255 )

0-255 Blue from 0-100%

Channel 7 – Fine Blue (CH1 and CH6 must be set between 001-255 )

0-255 Fine adjustment Blue from 0-100%

Channel 8 – White dimmer intensity (CH1 must be set between 001-255 )

0-255 White from 0-100%

Channel 9 – Fine White (CH1 and CH8 must be set between 001-255 )

0-255 Fine adjustment White from 0-100%

Channel 10 – Amber dimmer intensity (CH1 must be set between 001-255 )

0-255 Amber from 0-100%

Channel 11 – Fine Amber (CH1 and CH10 must be set between 001-255 )

0-255 Fine adjustment Amber from 0-100%

Channel 12 – Lime dimmer intensity (CH1 must be set between 001-255 )

0-255 Lime from 0-100%

Channel 13 – Fine Lime (CH1 and CH12 must be set between 001-255 )

0-255 Fine adjustment Lime from 0-100%

Channel 14 – UV dimmer intensity (CH1 must be set between 001-255 )

0-255 UV from 0-100%

Channel 15 – Fine UV (CH1 and CH14 must be set between 001-255 )

0-255 Fine adjustment UV from 0-100%

Channel 16 – Macros (CH1 must be set between 001-255 )

0-10	No function
11-30	Red 100% / Green Up / Blue 0%
31-50	Red Down / Green 100% / Blue 0%
51-70	Red 0% / Green 100% / Blue Up
71-90	Red 0% / Green Down / Blue 100%
91-110	Red Up / Green 0% / Blue 100%
111-130	Red 100% / Green 0% / Blue Down
131-150	Red 100% / Green Up / Blue Up
151-170	Red Down / Green Down / Blue 100%
171-195	Red 100% / Green 100% / Blue 100% / White 100% / Amber 100% / Lime 100% / UV 100%
196-200	White 1: 2700K
201-205	White 2: 3000K
206-210	White 3: 3200K
211-215	White 4: 3500K
216-220	White 5: 4000K
221-225	White 6: 4200K
226-230	White 7: 4500K
231-235	White 8: 5600K
236-240	White 9: 6000K
241-245	White 10: 6500K
246-250	White 11: 7200K
251-255	White 12: 8000K

Channel 17 – Strobe (CH1 & CH2, CH3, CH4, CH5, CH6, CH7, CH8, CH9, CH10, CH11, CH12, CH13 or CH14 must be set between 001-255 & CH16 between 11-255 )

0-9	No function
10-50	Strobe flash frequency, from slow to fast (0-25Hz)
51-100	No function
101-150	Pulse strobe, from slow to fast
151-200	No function
201-255	Random strobe, from slow to fast

Channel 18 – Auto program (CH1 must be set between 001-255 )

0-40	No function
41-50	AUTO01
51-60	AUTO02
61-70	AUTO03
71-80	AUTO04
81-90	AUTO05
91-100	AUTO06
101-110	AUTO07
111-120	AUTO08
121-130	AUTO09
131-140	AUTO10
141-150	PROGRAM1
151-160	PROGRAM2
161-170	PROGRAM3
171-180	PROGRAM4
181-190	PROGRAM5
191-200	PROGRAM6
201-210	PROGRAM7
211-220	PROGRAM8
221-230	PROGRAM9
231-255	PROGRAM10

Channel 19 – Auto speed (CH18 must be set between 41-140 )

0-255 Speed adjustment, from slow to fast

Channel 20 – Dimmer speed

0-9 No function

10-29 Off (RGBW and Master dimmer linear)

30-69 DIM1 (fastest)

70-129 DIM2

130-189 DIM3

190-255 DIM4 (slowest)

Maintenance

The operator has to make sure that safety-related and machine-technical installations are to be inspected by an expert after every year in the course of an acceptance test.

The operator has to make sure that safety-related and machine-technical installations are to be inspected by a skilled person once a year.

The following points have to be considered during the inspection:

- 01) All screws used for installing the device or parts of the device have to be tightly connected and must not be corroded.
- 02) There may not be any deformations on housings, fixations and installation spots.
- 03) Mechanically moving parts like axles, eyes and others may not show any traces of wearing.
- 04) The electric power supply cables must not show any damages or material fatigue.

The Eventspot 60 Q7 requires almost no maintenance. However, you should keep the unit clean.

Otherwise, the fixture's light-output will be significantly reduced. Switch off the device and then wipe the cover with a damp cloth. Wipe the front glass panel clean with glass cleaner and a soft cloth. Do not use alcohol or solvents. The front glass panel will require weekly cleaning, as smoke-fluid tends to build up residues, reducing the light-output very quickly. Do not immerse in liquid.

Keep connections clean. Make sure connections are thoroughly dry before linking equipment or supplying electric power.

Troubleshooting**No Light**

This troubleshooting guide is meant to help solve simple problems.

If a problem occurs, follow the steps below in sequence until a solution is found. Once the unit operates properly, do not carry out the following steps.

If the light effect does not operate properly, refer servicing to a technician.

Response: Suspect two potential problem areas: the battery and the LEDs.

- 01) Battery. Check if the battery is fully charged.
- 02) The LEDs. Return the Eventspot 60 Q7 to your Showtec dealer.
- 03) If all of the above appears to be in order, switch the unit on again.
- 04) If you are unable to determine the cause of the problem, do not open the Eventspot 60 Q7, as this may damage the unit and the warranty will become void.
- 05) Return the device to your Showtec dealer.

No Response to DMX

Response: Suspect the DMX cable or connectors, a controller malfunction, a light effect DMX card malfunction.

- 01) Check the DMX setting. Make sure that DMX addresses are correct.
- 02) Check the DMX cable: Unplug the unit; change the DMX cable; then reconnect to electrical power. Try your DMX control again.
- 03) Determine whether the controller or light effect is to blame. Does the controller operate properly with other DMX products? If not, take the controller in for repair. If it does, take the DMX cable and the light effect to a qualified technician.

Problem	Probable cause(s)	Remedy
One or more fixtures do not function at all	No power to the fixture.	<ul style="list-style-type: none"> • Check that power is switched on and the battery is charged (green LED in front should light continuously).
Fixtures reset correctly, but all respond erratically or not at all to the controller.	The controller is not connected. 3-pin XLR Out of the controller does not match XLR Out of the transmitter on the link (i.e. signal is reversed).	<ul style="list-style-type: none"> • Connect controller. • Install a phase reversing cable between the controller and the transmitter on the link.
Fixtures reset correctly, but some respond erratically or not at all to the controller.	Poor data quality	<ul style="list-style-type: none"> • Check data quality. If much lower than 100 percent, the problem may be a bad data link connection, poor quality or broken cables, missing termination plug, or a defective fixture disturbing the link.
	Bad data link connection	<ul style="list-style-type: none"> • Inspect connections and cables. Correct poor connections. Repair or replace damaged cables.
	Incorrect addressing of the fixtures.	<ul style="list-style-type: none"> • Check address setting.
No light	One of the fixtures is defective and disturbs data transmission on the link.	<ul style="list-style-type: none"> • Bypass one fixture at a time until normal operation is regained: unplug both connectors and connect them directly together. • Have the defective fixture serviced by a qualified technician.
	Fixture is too hot.	<ul style="list-style-type: none"> • Allow fixture to cool. • Make sure air vents at control panel and front lens are not blocked. • Turn up the air conditioning .
	LEDS damaged	<ul style="list-style-type: none"> • Disconnect fixture and return to your dealer.

Product Specifications

Model:	Showtec Eventspot 60 Q7
Input Voltage:	24V DC
Power consumption:	20W (full output)
Operating time at full RGBWA-UV-Lime	6 hours
Operation temperature	-20°C to +45°C
Charging time	6 hours
Protection rate:	IP54(temporary event)
Dimensions:	138 x 102 x 190 mm (LxWxH) (incl. bracket)
Weight:	1,14 kg
Operating and Programming:	
DMX Mode:	7, 10, 13 or 20 channels
Control Protocol:	DMX512 via wireless DMX512
Electro-mechanical effects:	
LED Quantity:	7 LED (RGBWA-UV-Lime)
Output (4,5°):	1400 Lux @ 2 meter
Output (45°):	68 Lux @ 2 meter
Maximum projection distance:	4m (depending on zoom angle)
Color mixing:	RGBWA-UV-Lime
Adjustable zoom angle:	4,5° to 45°
Field angle:	8° to 55°
Dimmer:	0-100%
Strobe:	0-25Hz
Housing:	Black plastic extrusion
On Board:	LCD-Display
Control:	Manual Color control, W-DMX
Fixture Connection:	24V DC connection
Cooling:	Convection
Max. ambient temperature t_a :	45°C
Max. housing temperature t_b :	80°C
Minimum distance:	
Minimum distance from flammable surfaces:	0,5 m
Minimum distance to lighted object:	1 m

Design and product specifications are subject to change without prior notice.



Website: www.Showtec.info

Email: service@highlite.nl

Dimensions

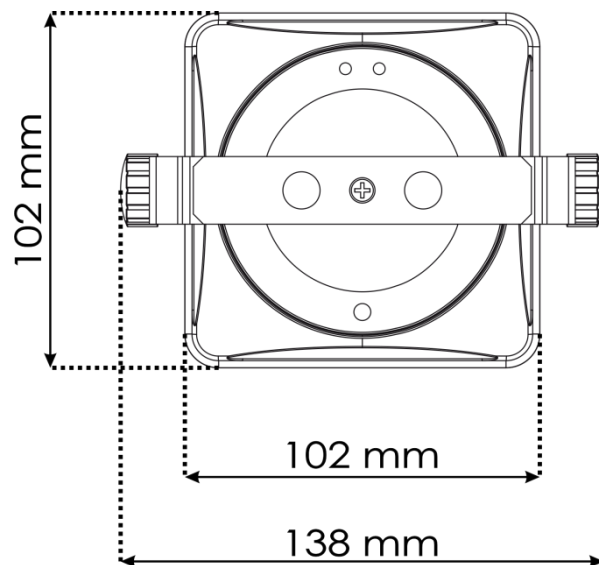
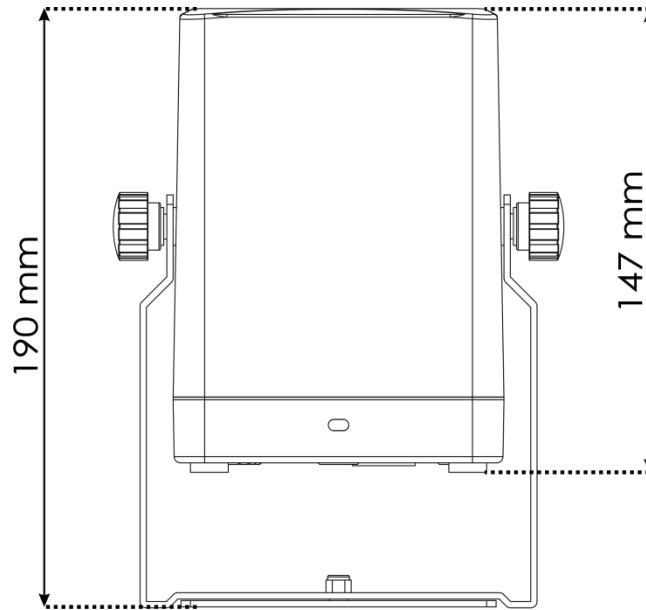



©2016 Showtec