

# RUSH MH 8 Mini Profile

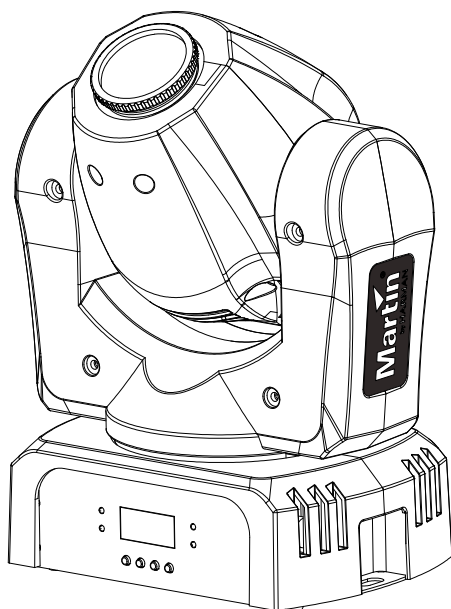

## User Manual

**Martin**<sup>®</sup>  
by HARMAN

© 2016 Martin Professional ApS. Information subject to change without notice. Martin Professional and all affiliated companies disclaim liability for any injury, damage, direct or indirect loss, consequential or economic loss or any other loss occasioned by the use of, inability to use or reliance on the information contained in this manual. The RUSH name, RUSH logo, Martin name and Martin logo and all other trademarks in this document pertaining to services or products by Martin Professional or its affiliates and subsidiaries are trademarks owned or licensed by Martin Professional or its affiliates or subsidiaries.

Martin Professional • Olof Palmes Allé 18 • 8200 Aarhus N • Denmark • [www.martin.com](http://www.martin.com)

**Manual: Revision A**

# Table of contents

Safety information .....	4
Introduction .....	8
Before using the product for the first time .....	8
Physical installation .....	9
Fastening the fixture to a flat surface .....	9
Mounting the fixture on a truss .....	9
AC power .....	11
Fixture overview .....	12
Control data link .....	13
Tips for reliable data transmission .....	13
Connecting the data link .....	13
Fixture setup .....	14
Using the control menus .....	14
DMX addressing .....	14
Behavior without DMX (DMX State) .....	14
Stand-alone settings .....	15
Pan/tilt inversion .....	16
Dimmer settings .....	17
Backlight .....	18
Fixture time .....	18
Reset .....	18
Fan mode .....	18
Home position adjustment (offsets menu) .....	19
Effects .....	20
Pan and tilt .....	20
Strobe effects .....	20
Electronic dimming .....	20
Colors .....	21
Gobos .....	21
Maintenance .....	22
Cleaning .....	22
Replacing the primary fuse .....	23
Service and repairs .....	23
DMX protocol .....	24
Control menus .....	27
Troubleshooting .....	29
Specifications .....	30

# Safety information



## WARNING!

**Read the safety precautions in this manual before installing, operating or servicing this product.**

The following symbols are used to identify important safety information on the product and in this manual:



**Warning!**

***Safety hazard. Risk of severe injury or death.***



**Warning!**

***Powerful light emission. Risk of eye injury.***



**Warning!**

***See user manual for important safety information.***



**Warning!**

***Hazardous voltage. Risk of lethal or severe electric shock.***



**Warning!**

***Hot surfaces.***



**Warning!**

***Fire hazard.***



**Warning!** Risk Group 2 product according to EN 62471. Possibly hazardous radiation emitted from this product. May be harmful to the eyes. Do not stare at operating lamp and do not view the light output with optical instruments or any device that may concentrate the beam.

This lighting fixture is for professional use only and must be installed by a qualified technician. It is not for household use. It presents risks of severe injury or death due to fire hazards, electric shock and falls. It produces a powerful, concentrated beam of light that can create a fire hazard or a risk of eye injury if the safety precautions below are not followed.



Install, operate and service Martin™ products only as directed in their user manuals, or you may create a safety hazard or cause damage that is not covered by product warranties.

Follow the safety precautions listed below and observe all warnings in this manual and printed on the product. Keep this user manual for future use.

For the latest user documentation and other information for this and all Martin™ products, please visit the Martin website at

<http://www.martin.com>

If you have any questions about how to install, operate or service the fixture safely, please contact your Martin™ distributor (see [www.martin.com/distributors](http://www.martin.com/distributors) for details) or call the Martin™ 24-hour service hotline on +45 8740 0000, or in the USA on 1-888-tech-180.

Respect all locally applicable laws, codes and regulations when installing, operating or servicing the fixture.



### **Protection from electric shock**

Do not expose the fixture to rain or moisture.

Disconnect the fixture from AC power before carrying out any installation or maintenance work and when the fixture is not in use.

Ensure that the fixture is electrically connected to ground (earth).

Use only a source of AC power that complies with local building and electrical codes and has both overload and ground-fault (earth-fault) protection.

Socket outlets or external power switches used to supply the fixture with power must be located near the fixture and easily accessible so that the fixture can easily be disconnected from power.

Replace defective fuses with ones of the specified type and rating only.

Isolate the fixture from power immediately if the power plug or any seal, cover, cable, or other component is damaged, defective, deformed, wet or showing signs of overheating. Do not reapply power until repairs have been completed

Before using the fixture, check that all power distribution equipment and cables are in perfect condition and rated for the electrical requirements of all connected devices.



### **Protection from burns and fire**

Do not operate the fixture if the ambient temperature ( $T_a$ ) exceeds 40° C (104° F).



The surface of the product casing can reach up to 45° C (113° F) during operation. Avoid contact by persons and materials. Allow the fixture to cool for at least 10 minutes before handling.

Keep flammable materials well away from the fixture. Keep all combustible materials (e.g. fabric, wood, paper) at least 100 mm (4 in.) away from the fixture head.

Ensure that there is free and unobstructed airflow around the fixture. Provide a minimum clearance of 100 mm (4 in.) around fans and air vents.

Do not illuminate surfaces within 200 mm (8 in.) of the fixture.

Do not attempt to bypass thermostatic switches or fuses.

Do not stick filters, masks or other materials onto any optical component.

The fixture's lenses can focus the sun's rays inside the fixture, creating a risk of fire and damage. Do not expose the front of the fixture to sunlight or any other bright light source.



### **Protection from eye injury**

The light from the LED lamp is possibly hazardous and may be harmful to the eyes. Do not stare directly into the product's light output.

Do not look at the light output with magnifiers, telescopes, binoculars or similar optical instruments that may concentrate the light output.

Ensure that persons are not looking directly into the LEDs when the product lights up suddenly. This can happen when power is applied, when the product receives a DMX signal, or when certain control menu items are selected.

To minimize the risk of eye irritation or injury, disconnect the fixture from power at all times when the fixture is not in use, and provide well-lit conditions to reduce the pupil diameter of anyone working on or near the fixture.



## Protection from injury

Fasten the fixture securely to a fixed surface or structure when in use. The fixture is not portable when installed.

Ensure that any supporting structure and/or hardware used can hold at least 10 times the weight of all the devices they support.

If suspending from a rigging structure, fasten the fixture to a rigging clamp. Do not use safety cables as the primary means of support.

If the fixture is installed in a location where it may cause injury or damage if it falls, install as directed in this manual a secondary attachment such as a safety cable that will hold the fixture if a primary attachment fails. The secondary attachment must be approved by an official body such as TÜV as a safety attachment for the weight that it secures, must comply with EN 60598-2-17 Section 17.6.6 and must be capable of bearing a static suspended load that is ten times the weight of the fixture and all installed accessories.

Allow enough clearance around the head to ensure that it cannot collide with an object or another fixture when it moves.

Check that all external covers and rigging hardware are securely fastened.

Block access below the work area and work from a stable platform whenever installing, servicing or moving the fixture.

Do not operate the fixture with missing or damaged covers, shields or any optical component.

Do not lift or carry the fixture by its head. Support the fixture by its base only.

In the event of an operating problem, stop using the fixture immediately and disconnect it from power. Do not attempt to use a fixture that is obviously damaged.

Do not modify the fixture in any way not described in this manual or install other than genuine Martin™ parts.

Refer any service operation not described in this manual to a qualified technician.

# Introduction

The RUSH™ MH 8 Mini Profile is a fast, compact moving head profile fixture with an 18 W long-life LED engine. It provides an 8-position plus open gobo wheel, an 8-position plus open color wheel, smooth electronic dimming, strobe effects, and a manually adjustable focus lens. The rugged, lightweight construction makes it ideal for mobile DJs, touring, and small venues.

The fixture is supplied with this user manual, a 1.9 m (6 ft.) power cable ready for a local power plug (not included), a second power cable fitted with a US power plug, and a mounting bracket for attachment of a suitable, user-supplied rigging clamp.

## Before using the product for the first time

1. Read 'Safety information' starting on page 4 before installing, operating or servicing the fixture.
2. Unpack and ensure that there is no transportation damage before using the fixture. Do not attempt to operate a damaged fixture.
3. (Outside U.S.A.) If the fixture is not going to be hard-wired to a mains supply, install a local power plug (not supplied) to the end of the supplied power cable.
4. Before operating, ensure that the voltage and frequency of the power supply match the power requirements of the fixture.
5. Check the support pages on the Martin Professional website at [www.martin.com](http://www.martin.com) for the most recent user documentation and technical information about the fixture. Martin™ user manual revisions are identified by the revision letter at the bottom of the inside cover.

Note that whenever AC power is applied to the fixture, it will reset all effects and functions to their home positions. Be prepared for the fixture head to move. A reset usually takes around 20 seconds.



# Physical installation



**Warning! Read 'Safety information' on page 4 before installing the fixture.**

The fixture is designed for indoor use only and must be used in a dry location with adequate ventilation. Ensure that none of the fixture's ventilation slots are blocked and all minimum distances are observed.

The fixture must be installed by a qualified technician. It must be oriented vertically, either upright on the floor or other horizontal surface, or suspended upside-down from a suitable structure.

Fasten the fixture to a secure structure or surface. Do not stand it on a surface or leave it where it can be moved or fall over. If you install the fixture in a location where it may cause injury or damage if it falls, secure it as directed in this user manual using a securely anchored safety cable that will hold the fixture if the primary fastening method fails.

Martin™ can supply safety cables and rigging clamps that are suitable for use with the fixture (see 'Accessories' on page 32).

## Fastening the fixture to a flat surface

The fixture can be fastened to a hard, fixed, flat surface. Ensure that the surface and all fasteners used can support at least 10 times the weight of all fixtures and equipment they will support.

Fasten the fixture securely. Do not stand it on a surface or leave it where it can be moved or fall over. If you install the fixture in a location where it may cause injury or damage if it falls, secure it as directed below with a securely anchored safety cable that will hold the fixture if the primary fastening method fails.

## Mounting the fixture on a truss

The fixture can be clamped to a truss or similar rigging structure. It must be suspended vertically, hanging downwards only. Use a suitable rigging clamp such as a G-clamp or a half-coupler clamp (see illustration on right) fastened to the included clamp attachment bracket.



To clamp the fixture to a truss:

1. Check that the rigging structure can support at least 10 times the weight of all fixtures and equipment to be installed on it.
2. Block access under the work area.

3. Bolt a rigging clamp securely to the supplied clamp-attachment bracket. The bolt used must be M12, grade 8.8 steel minimum, and fastened with a self-locking nut.
4. Fasten the bracket to the fixture by screwing the two hex socket (Allen) bolts provided fully into holes **A** in the base of the fixture (see illustrations on right and below) using the washers provided or suitable lock washers.
5. Working from a stable platform, hang the fixture vertically on the truss and fasten the rigging clamp onto the truss.
6. Secure the fixture with a safety cable as directed below.
7. Check that the head will not collide with other fixtures or objects.

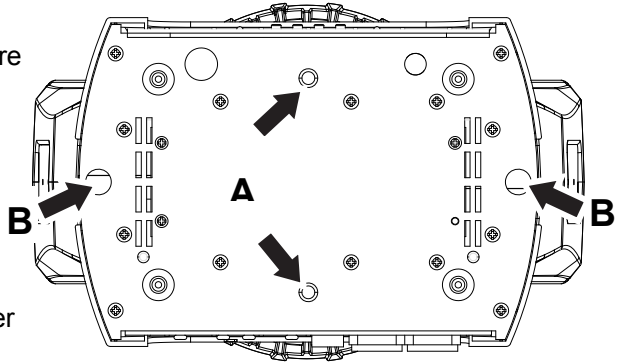

### Securing with a safety cable

Secure the fixture with a safety cable (or other secondary attachment) that is approved for the weight of the fixture so that the safety cable will hold the fixture if the primary attachment fails. Loop the safety cable through one of the two attachment points **B** in the base of the fixture base (see illustrations above and to right) and around a secure anchoring point.

If a safety cable attachment point becomes damaged or deformed, do not use the fixture. Return it to Martin™ for repair.

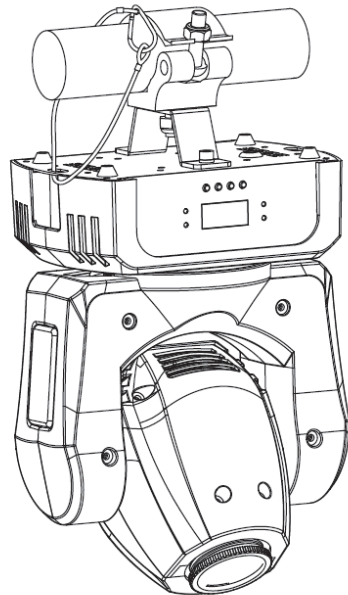

# AC power



**Warning! Read ‘Safety information’ on page 4 before connecting the fixture to AC mains power.**

For protection from electric shock, the fixture must be grounded (earthed). The power distribution circuit must be equipped with a fuse or circuit breaker and ground-fault (earth-fault) protection.



Socket outlets or external power switches used to supply the fixture with power must be located near the fixture and easily accessible so that the fixtures can easily be disconnected from power.

Do not use an external dimming system to supply power to the fixture, as this may cause damage to the fixture that is not covered by the product warranty.

The fixture can be hard-wired to a building electrical installation if you want to install it permanently, or a power plug (not supplied) that is suitable for the local power outlets can be installed on the power cable. Socket outlets or external power switches used to supply the fixture with power must be located near the fixture and easily accessible so that the fixture can easily be disconnected from power.

If you install a power plug on the power cable, install a grounding type (earthed) plug with integral cable grip that is rated minimum 250 V, 6 A. Follow the plug manufacturer’s instructions and connect the wires in the power cable as shown in this table:

	<b>Live or L</b>	<b>Neutral or N</b>	<b>Earth, Ground or Ⓧ</b>
<b>US system</b>	Black	White	Green
<b>EU system</b>	Brown	Blue	Yellow/green

The fixture has an auto-ranging power supply that accepts AC mains power at 100-240 V at 50/60 Hz. Do not apply AC mains power at any other voltage or frequency to the fixture.

# Fixture overview

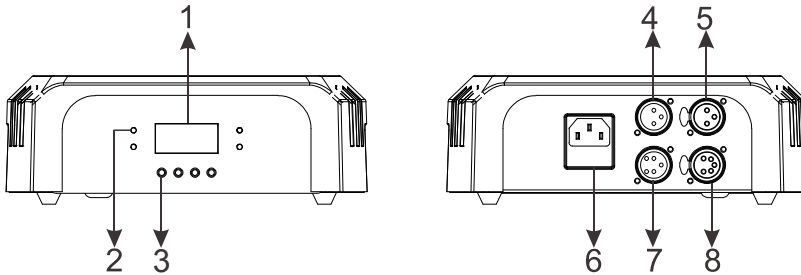

## 1 – Display

## 2 – LEDs

Four LEDs provide status information.

- DMX: Valid DMX signal present.
- SLAVE: Fixture operating as a stand-alone slave.
- MASTER: Fixture operating as the stand-alone master.
- SOUND: Audio signal triggering stand-alone sequence.

## 3 – Control buttons

- MENU: Press to activate the menu. Within the menu, press to escape and return to the previous level. Press and hold to exit the menu.
- DOWN: Press to scroll down through menu options.
- UP: Press to scroll up through menu options.
- ENTER: Press to confirm and save the menu selection.

## 4, 5 – 3-pin XLR DMX input/output

For your convenience, 3 and 5-pin XLR sockets are provided for DMX input and output (throughput).

## 6 – AC mains power socket and primary fuse holder

The IEC mains power input socket includes the holder for the T 2.0 A primary fuse. A spare fuse is located behind the fuse holder.

## 7, 8 – 5-pin DMX input/output

## Control data link

A DMX 512 data link is required in order to control the fixture via DMX. The fixture has 3-pin and 5-pin XLR connectors for DMX data input and output.

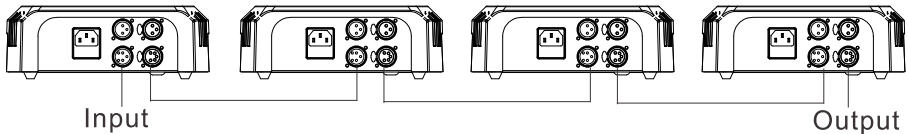

Up to 32 devices can be linked together on a single daisy chain. The total number of fixtures in one 512-channel DMX universe is limited by the number of DMX channels required by the fixtures. Note that if independent control of a fixture is required, it must have its own DMX channels. Fixtures that are required to behave identically can share the same DMX address and channels. To add more fixtures or groups of fixtures when the above limits are reached, add a DMX universe and/or split the daisy-chained link into branches.

### Tips for reliable data transmission

Use shielded twisted-pair cable designed for RS-485 devices: standard microphone cable cannot transmit control data reliably over long runs. 24 AWG cable is suitable for runs up to 300 meters (1000 ft.). Heavier gauge cable and/or an amplifier is recommended for longer runs. The pin-out on all connectors is pin 1 = shield, pin 2 = cold (-), and pin 3 = hot (+). Pins 4 and 5 in the 5-pin XLR connectors are not used in the fixture but are available for possible additional data signals as required by the DMX512-A standard. Standard pin-out is pin 4 = data 2 cold (-) and pin 5 = data 2 hot (+).

To split the link into branches, use an opto-isolated splitter such as the Martin™ DMX 5.3 Splitter. Terminate the link by installing a termination plug in the output socket of the last fixture. The termination plug, which is a male XLR plug with a 120 Ohm, 0.25 W resistor soldered between pins 2 and 3, “soaks up” the control signal so it does not reflect and cause interference. If a splitter is used, terminate each branch of the link.

### Connecting the data link

To connect the fixture to data:

1. Connect the DMX data output from the controller to the closest fixture’s male XLR DMX input connector.
2. Connect the first fixture’s DMX output to the DMX input of the next fixture and continue connecting fixtures output to input. Terminate the last fixture on the link with a DMX termination plug.

## Fixture setup

This section explains the fixture characteristics that can be set that determine how it can be controlled and will behave. These settings are made using the menus available from the control panel, and are retained, even when the fixture is powered off.

Only the most commonly used menu options for fixture setup are described in this section. A complete map of the control menu structure and brief explanations of their purposes can be found on page 24.

### Using the control menus

To access the control menus, press the MENU button. Navigate the menu structure using the ENTER, DOWN and UP buttons. To select a menu option or to confirm a selection, press the ENTER button. To return to a higher level in the menu structure without making a change, press the MENU button.

To exit the control menus completely, press and hold the MENU button.

### DMX addressing

The DMX address, also known as the start channel, is the first channel used to receive instructions from a DMX controller. The fixture is controlled using ten (10) DMX channels. Each DMX controlled fixture must have a DMX address set. For example, if a fixture has a DMX address of 10, then it uses channels 10, 11, 12, 13, 14, 15, 16, 17, 18, and 19. The following fixture in the DMX chain could then be set to a DMX address of 20.

For independent control, each fixture must be assigned its own control channels. Two fixtures of the same type may share the same address if identical behavior is desired. Address sharing can be useful for diagnostic purposes and symmetric control, particularly when combined with the inverse pan and tilt options.

To set the fixture's DMX address:

1. In the control menu, select DMX ADDRESS and press ENTER to confirm. The present address will blink in the display.
2. Use the UP and DOWN buttons to select an address from 1 to 503.
3. Press ENTER to confirm your selection.

### Behavior without DMX (DMX State)

The DMX STATE setting determines how the fixture behaves when it is not receiving a DMX signal. You can set the fixture to enter Show Mode, black out, or hold the effect it was displaying when the DMX signal stopped. The fixture is set to BLACKOUT by default.

To adjust the setting:

1. Select DMX STATE and press ENTER. The currently set option will blink in the display.
2. Use the DOWN and UP buttons to select SHOW MODE (fixture enters Show Mode), BLACKOUT (fixture blacks out) or HOLD (fixture shows the last effect it was displaying before the DMX signal stopped).
3. Press ENTER to save your selection.

## **Stand-alone settings**

The fixture will operate in stand-alone mode if it is not receiving a DMX signal and the DMX STATE menu option is set to SHOW MODE (see above), or if you enter the SHOW MODE menu in the control panel.

### ***Stand-alone show selection (Show Mode)***

Four pre-programmed stand-alone shows are available. To set the show that the fixture will run in Show Mode:

1. Select SHOW MODE and press ENTER to confirm. The currently selected show will blink in the display.
2. Use the DOWN and UP buttons to select Show 1, 2, 3 or 4.
3. Press ENTER to save your selection.

### ***Master/slave operation***

Fixtures in Show Mode can be linked in a chain and set to master/slave operation, where one master fixture running a standalone show controls the behavior of slave fixtures. Two slave modes are available:

- Fixtures in Slave 1 mode copy the master.
- Fixtures in Slave 2 mode are synchronized with the master but have slight variations in behavior.

You must set all the fixtures except one as slaves. If you set more than one fixture in the chain to act as master, you may cause damage that is not covered by the product warranty.

To operate fixtures in master/slave mode:

1. Link fixtures in a chain, using DMX cable to connect one fixture's DMX OUT socket to the next fixture's DMX IN socket. See 'Control data link' on page 13.
2. In the MASTER SLAVE menu, set one fixture to MASTER and set all the other fixtures to SLAVE 1 or SLAVE 2.
3. Set the master fixture in the chain to run one of its four standalone shows using its SHOW MODE menu (see 'Show Mode' above).

4. Set all the fixtures in the chain to DMX STATE → SHOW MODE.
5. Make sure that the fixtures are not receiving a DMX signal.

### **Sound activation in show mode**

Show Mode can be combined with sound activation. The fixture has a built-in microphone that can be used to trigger scene changes in sync with a music beat (music trig) when the fixture is running in Show Mode.

To enable sound activation:

1. Select SOUND MODE and press ENTER.
2. Use the DOWN and UP buttons to select ON (sound activation enabled) or OFF (sound activation disabled).
3. Press ENTER to save your selection.

To adjust the sensitivity of sound activation to the volume of the music:

1. Turn on the music source and set it to the desired volume.
2. Select SOUND SENSE and press ENTER.
3. Use the DOWN and UP buttons to change the sensitivity level from 0 to 100.
4. When the fixture responds correctly to the beat, press ENTER to save your selection.

### **Pan/tilt inversion**

The PAN INVERSE and TILT INVERSE menus can be used to reverse the direction of pan and tilt. These settings are useful for symmetrical effects with multiple fixtures, or when coordinating the movement of fixtures that are floor mounted and rigged upside down.

To adjust the pan inversion settings:

1. Select PAN INVERSE and press ENTER to confirm. The currently set mode will blink in the display.
2. Use the DOWN and UP buttons to select YES (tilt inversion) or NO (normal) mode.
3. Press ENTER to save your selection.

To adjust the tilt inversion settings:

1. Select TILT INVERSE and press ENTER to confirm. The currently set mode will blink in the display.
2. Use the DOWN and UP buttons to select YES (tilt inversion) or NO (normal) mode.
3. Press ENTER to save your selection.



## Dimmer settings

### *Dimming curve*

Four dimming curves are available to modify dimmer response. The default is MODE 2. The settings affect response as follows:

- MODE 1    LINEAR: the increase in light intensity appears to be linear as DMX value is increased.
- MODE 2    SQUARE LAW: light intensity control is finer at low levels and coarser at high levels.
- MODE 3    INVERSE SQUARE LAW: light intensity control is coarser at low levels and finer at high levels.
- MODE 4    S-CURVE: light intensity control is finer at low levels and high levels and coarser at medium levels.

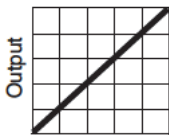

Optically linear

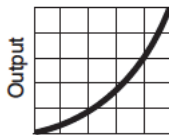

Square law

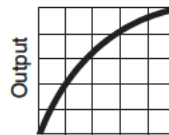

Inverse square law

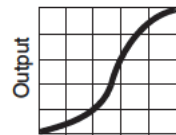

S-curve

To set the fixture's dimmer curve:

1. Select DIMMER CURVE and press ENTER to confirm. The mode that is currently active will blink in the display.
2. Use the DOWN and UP buttons to select the desired mode.
3. Press ENTER to save your selection.

### *Dimmer speed*

There are two dimmer speed options:

- SNAP is the default setting. It sets the dimmer to exactly follow changes in dimming level sent from the controller. This gives the fastest dimmer response.
- FADE adds an approximate two-second smooth fade to changes in dimming level sent from the controller. This gives the smoothest dimmer fading.

To set the dimmer speed:

1. Select DIMMER SPEED and press ENTER to confirm.
2. Use the DOWN and UP buttons to select SNAP or FADE. Press ENTER to confirm.

## ***Dimmer calibrate***

The dimmer calibration function allows you to decrease output to achieve uniform dimming with other fixtures. (If a fixture's output appears to be low, verify that the DIMMER CALIBRATE level is 100.)

To calibrate dimming on a fixture on which the light output is too high:

1. Select DIMMER CALIBRATE and press ENTER to confirm.
2. Use the DOWN and UP buttons to adjust light output to a level between 50 and 100. The default level is 100 (full intensity).
3. Press ENTER to confirm.

## **Backlight**

To turn the control panel display backlight on or off:

1. Select BACK LIGHT and press ENTER to confirm. The present mode will blink in the display.
2. Use the DOWN and UP buttons to select ON or OFF.
3. Press ENTER to save your selection.

## **Fixture time**

To display the fixture's operating hours counter, select FIXTURE TIME and press ENTER. The display will show the number of hours the fixture has been in operation since manufacture. Press MENU to exit.

## **Reset**

The fixture resets each time you power it on, but you can also reset the fixture manually from the control panel and by DMX. To carry out a manual reset, scroll to RESET and press ENTER to reset the fixture, or press MENU to exit without resetting. A reset takes approx. 20 seconds. After this, the fixture returns to its state before the reset.

## **Fan mode**

Fan speed can be adjusted to maximize light output or quiet operation.

1. Select FAN MODE and press ENTER.
2. Using the DOWN and UP buttons, toggle between the two modes:
  - LOW. Fans run at constant low speed for quieter operation. Light output is reduced when necessary to control fixture temperature.
  - AUTO. Fan speed increases when necessary to control fixture temperature, but light output is constant.
3. Press ENTER to confirm your choice.

## Home position adjustment (offsets menu)

If the fixture head, gobo wheel, or color wheel does not return to its home position, even after a reset, you can adjust the home position by defining offsets.

To make the adjustment from the control panel:

1. Reset the fixture as described above.
2. Press and hold ENTER for at least 3 seconds to enter Offset mode.
3. Use the DOWN and UP buttons up to choose a function to adjust: PAN, TILT, GOBO, or COLOR. Press ENTER
4. Use the DOWN and UP buttons to adjust the effect's home or open position.
5. Press ENTER to save your selection (or press MENU to exit without saving any changes).

## Effects

See 'DMX protocol' on page 24 for a full list of the DMX channels and values required to control the different effects.

### Pan and tilt

The fixture's head can be panned through 540° and tilted through 230° with 16-bit coarse and fine control. Using the control menus it is possible to invert pan or tilt movement.

Light output can be blacked out when the head moves with the "Auto-blackout = ON" command (DMX level 145 to 149) on channel 10. To turn this feature off, use the "Auto-blackout = OFF" command. Pan and tilt speed can also be set to slow, medium, or fast using commands on channel 10.

The pan and tilt home position, as well as the open gobo position, can be adjusted from the controller. To make adjustments via DMX:

1. Select the fixture on the controller.
2. Enable calibration (DMX value 55-59) on the fixture's DMX channel 10, Fixture Control Settings.
3. Adjust the effect's position using its DMX channel.
4. Store the effect's calibration value on DMX channel 10. Store both pan and tilt calibration with DMX value 165-169, gobo wheel calibration with DMX value 210-214, pan calibration only with DMX value 235-249, or tilt calibration only with DMX value 240-244.
5. When finished calibrating effects, set channel 10 to "No function" to resume normal DMX control.

### Strobe effects

The fixture electronically provides instant open and blackout, variable speed flash from 3 to 20 flashes per second, random strobe effects, and pulsing effects.

### Electronic dimming

Overall intensity can be precisely adjusted from 0 to 100% using 16-bit coarse and fine electronic dimming.

Four different dimming curves are available (see 'Dimmer settings on page 17). The dimming curve can be selected from the control menu or by DMX commands on channel 10.

## Colors

The color wheel provides eight colors plus an open white position. See the DMX protocol for details. Colors can be individually selected or scrolled to give split colors. The wheel can be rotated at varying speeds, both clockwise and counter-clockwise, or set to display random colors at slow, medium and fast speeds.

## Gobos

The gobo wheel provides eight gobo patterns, shown below, plus an open white position. Gobos can be stepped, or continuously scrolled to give split gobo patterns. The wheel can be rotated at varying speeds, both clockwise and counter-clockwise, or set to display random gobos at slow, medium and fast speeds.

Adjust the focus lens manually to project the sharpest image.



Gobo 1

Gobo 2

Gobo 3

Gobo 4

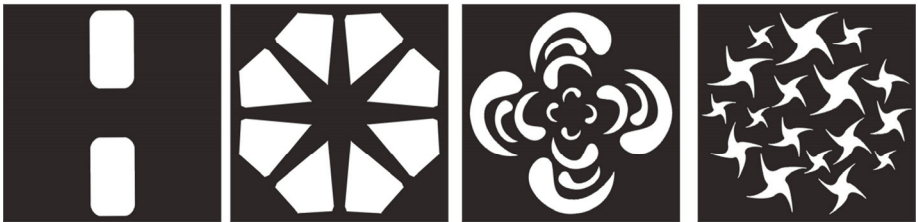

Gobo 5

Gobo 6

Gobo 7

Gobo 8

To avoid passing the open white position when changing colors and gobos, use the “Parameter shortcuts = OFF” command on channel 10. For faster color and gobo changes, use Parameter shortcuts = ON”.

# Maintenance



**Warning! Read ‘Safety information’ on page 4 before servicing the fixture.**

There are no user serviceable parts inside the fixture. Do not open the housing. Refer any service operation not described in this user manual to a qualified service technician.

Disconnect the fixture from mains power before cleaning or servicing.

Service fixtures in an area where there is no risk of injury from failing parts, tools or other materials.

The user may carry out the service operations described in this manual. All other service operations must be carried out by an authorized Martin™ service technician. Do not try to repair the fixture yourself, as you may create a safety risk or cause damage that is not covered by the product warranty.

Installation, on-site service and maintenance can be provided worldwide by the Martin Professional™ Global Service organization and its approved agents, giving owners access to Martin’s expertise and product knowledge in a partnership that will ensure the highest level of performance throughout the product’s lifetime. Please contact Martin™ for details.

## Cleaning

Excessive dust, smoke fluid, and particle buildup degrades performance, causes overheating and will damage the fixture. Damage caused by inadequate cleaning or maintenance is not covered by the product warranty.

The cleaning of external optical lenses must be carried out periodically to optimize light output. Cleaning schedules for lighting fixtures vary greatly depending on the operating environment. It is therefore impossible to specify precise cleaning intervals for the fixture. Environmental factors that may result in a need for frequent cleaning include:

- Use of smoke or fog machines.
- High airflow rates (near air conditioning vents, for example).
- Presence of cigarette smoke.
- Airborne dust (from stage effects, building structures and fittings or the natural environment at outdoor events, for example).

If one or more of these factors is present, inspect fixtures within their first 100 hours of operation to see whether cleaning is necessary. Check again at frequent intervals. This procedure will allow you to assess cleaning requirements in your particular situation. If in doubt, consult your Martin dealer about a suitable maintenance schedule.

Use gentle pressure only when cleaning, and work in a clean, well-lit area. Do not use any product that contains solvents or abrasives, as these can cause surface damage.

To clean the fixture:

1. Disconnect the fixture from power and allow it to cool for at least 10 minutes.
2. Vacuum or gently blow away dust and loose particles from the outside of the fixture and the air vents at the back and sides of the head and in the base with low-pressure compressed air.
3. Clean surfaces by wiping gently with a soft, clean lint-free cloth moistened with a weak detergent solution. Do not rub glass surfaces hard: lift particles off with a soft repeated press. Dry with a soft, clean, lint-free cloth or low-pressure compressed air. Remove stuck particles with an unscented tissue or cotton swab moistened with glass cleaner or distilled water.
4. Check that the fixture is dry before reapplying power.

## Replacing the primary fuse

If the fixture is completely dead, the fixture's primary fuse F1 may have blown and it may be necessary to install a new fuse. This fuse is located in the fuse holder below the mains input socket along with a spare. Replace with a fuse of the same size and specified rating only.

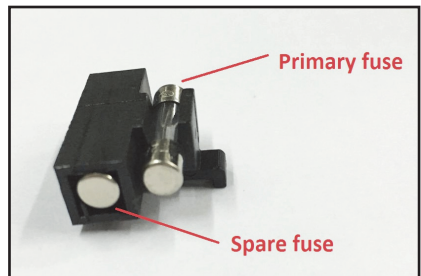

If you need to replace the fuse:

1. Disconnect the fixture from power and allow it to cool.
2. Remove the fuse holder and replace the spent fuse with the spare fuse.
3. Close the fuse holder before reapplying power.

## Service and repairs

Never try to repair the fixture by yourself as this may result in damage or malfunction and it may potentially void your product warranty. The equipment must only be serviced or repaired by an authorized Martin service technician.

# DMX protocol

Channel	Value	Function
1	0-255	Dimmer Coarse: 0-100%
2	0-255	Dimmer Fine
3	0-7	<b>Strobe</b> Off
	8-15	Open
	16-131	Strobe, slow to fast
	132-167	Fast close, slow open
	168-203	Fast open, slow close
	204-239	Pulse open and close
	240-247	Random strobe
	248-255	Open
4	0	<b>Color Wheel</b> Open
	1-14	Open → Red
	15	Red
	16-29	Red → Orange
	30	Orange
	31-44	Orange → Yellow
	45	Yellow
	46-59	Yellow → Light Green
	60	Light Green
	61-74	Light Green → Dark Blue
	75	Dark Blue
	76-89	Dark Blue → Magenta
	90	Magenta
	91-104	Magenta → Light Blue
	105	Light Blue
	106-119	Light Blue → Pink
	120	Pink
	121-134	Pink → Open
	135-160	Open
	161-163	<b>Stepped Scroll</b> Red
	164-166	Orange
	167-169	Yellow
	170-172	Light Green
	173-175	Dark Blue
176-178	Magenta	
179-181	Light Blue	
182-184	Pink	
185-192	Open	
193-214	<b>Continuous Rotation</b> CW, Fast → Slow	
215-221	Stop	
222-243	CCW, Slow → Fast	



Channel	Value	Function
4 cont.	244-247 248-281 252-255	<b>Random Colors</b> Fast Medium Slow
5	0 1-14 15 16-29 30 31-44 45 46-59 60 61-74 75 76-89 90 91-104 105 106-119 120 121-134 135-160  161-163 164-166 167-169 170-172 173-175 176-178 179-181 182-184 185-192  193-214 215-221 222-243  244-247 248-251 252-255	<b>Gobo Wheel</b> Open Open → Gobo 1 Gobo 1 Gobo 1 → Gobo 2 Gobo 2 Gobo 2 → Gobo 3 Gobo 3 Gobo 3 → Gobo 4 Gobo 4 Gobo 4 → Gobo 5 Gobo 5 Gobo 5 → Gobo 6 Gobo 6 Gobo 6 → Gobo 7 Gobo 7 Gobo 7 → Gobo 8 Gobo 8 Gobo 8 → Open Open <b>Stepped Scroll</b> Gobo 1 Gobo 2 Gobo 3 Gobo 4 Gobo 5 Gobo 6 Gobo 7 Gobo 8 Open <b>Continuous Rotation</b> CW, Fast → Slow Stop CCW, Slow → Fast <b>Random Gobos</b> Fast Medium Slow
6	0-255	<b>Pan:</b> 0° → 540°
7	0-255	<b>Pan (fine)</b>
8	0-255	<b>Tilt:</b> 0° → 230°
9	0-255	<b>Tilt (fine)</b>

10	0-9	<b>Fixture Control Settings</b> <i>No function</i> (disables calibration)
	10-14	Reset fixture
	15-19	<i>No function</i>
	20-24	Reset color
	25-29	<i>No function</i>
	30-34	Reset pan and tilt
	35-54	<i>No function</i>
	55-59	Enable calibration
	60-64	Linear dimmer curve
	65-69	Square law dimmer curve (default)
	70-74	Inverse square law dimmer curve
	75-79	S-curve dimmer curve
	80-84	Pan and tilt speed = Normal
	85-89	Pan and tilt speed = Fast (default)
	90-94	Pan and tilt speed = Slow
	95-99	Parameter shortcuts = ON (default)
	100-104	Parameter shortcuts = OFF
	105-144	<i>No function</i>
	145-149	Auto-blackout = On
	150-154	Auto-blackout = Off (default)
	155-159	Illuminate display
	160-164	Turn off display
	165-169	Store pan & tilt calibration
	170-209	<i>No function</i>
	210-214	Store gobo wheel calibration
215-234	<i>No function</i>	
235-239	Store pan calibration	
240-244	Store tilt calibration	
245-249	Reset all calibrations to factory default	
250-255	<i>No function</i>	

## Control menus

To access the control menus, press the MENU button. Use the UP and DOWN buttons to navigate the menus. Select a menu option with the ENTER button. For more information, see 'Using the control menus' on page 14.

Default fixture settings are shown in **bold**.

Menu	Sub-menu	Explanation
DMX Address	1–512	Fixture DMX address setting
Show Mode	<b>Show 1</b> ...Show 4	Select stand-alone program
Master Slave	Master	Fixture acts as master
	<b>Slave 1</b>	Slave copies master
	Slave 2	Slave synced by master
Sound Mode	<b>On</b>	Toggle music trigger for stand-alone operation
	Off	
Sound Sense	0...100 (default <b>90</b> )	Microphone sensitivity for music trigger
DMX State	Show Mode	Fixture behavior if DMX control signal is missing or lost
	<b>Blackout</b>	
	Hold	
Dimmer Curve	Mode 1	Optically linear
	<b>Mode 2</b>	Square law
	Mode 3	Inverse square law
	Mode 4	S-curve
Dimmer Speed	Fade	Smoother dimming
	<b>Snap</b>	Faster dimming
Dimmer Calibrate	<b>50-100</b>	Adjust max. output
Back light	On	Toggle display panel backlight
	<b>Off</b>	
Pan Inverse	Yes	Invert pan control
	<b>No</b>	Normal pan control
Tilt Inverse	Yes	Invert tilt control
	<b>No</b>	Normal tilt control
Auto test		Run test routine

Menu	Sub-menu	Explanation
Manual Test	Pan	Manual control of all effects
	Tilt	
	Color	
	Gobo	
	Shutter	
	Dimmer	
LED Temp.		Temperature readout
Fan Mode	<b>Auto</b>	Optimize cooling for light output intensity
	Low	Optimize cooling for quietness (output intensity is reduced if necessary to limit temperature)
Firmware Version		Currently installed firmware version
Fixture Time		Fixture operating hours counter
PRO Defaults	Yes	Restore factory default settings
	<b>No</b>	Exit
Reset	Yes	Force a fixture reset
	<b>No</b>	

To access the Offset menu, press MENU to enter the menu structure and then press and hold ENTER for three seconds.

Menu	Sub-menu	Setting	Explanation
Offset Menu	Pan	-127→127	Pan offset
	Tilt	-127→127	Tilt offset
	Gobo	-127→127	Gobo offset
	Color	-127→127	Color offset

# Troubleshooting

This section describes a few common problems that may occur during operation and provides some suggestions for easy troubleshooting:

Symptom	Potential Causes	Remedies
No light from fixture, or fans not working.	Power supply issue such as blown fuse, faulty connector or damaged cable.	<p>Ensure that the mains supply is connected and supplying power to the fixture.</p> <p>Check all power connections and cables.</p> <p>Check and if necessary replace the fixture fuse.</p>
One of the control channels is unresponsive or only responds intermittently.	<p>DMX setup or DMX link fault.</p> <p>Damaged step motor or cable connection between head and body.</p>	<p>See next section.</p> <p>Contact your Martin authorized distributor or service center for assistance.</p>
Fixture does not respond to DMX control.	Fault in the DMX network due to connector or cable damage, incorrect DMX addressing, or potential interference from proximity to a high voltage installation.	<p>Ensure that fixture's DMX address matches address set on DMX control device.</p> <p>Check that fixture DMX LED is on, and if not, check all DMX cables and connections.</p> <p>Ensure that DMX link is terminated.</p> <p>Check that all components on DMX link use standard DMX polarity.</p> <p>Attempt to control the fixture with another DMX control device.</p> <p>Move or shield link if it is close to an unshielded high-voltage installation.</p>

# Specifications

## Physical

Dimensions (LxWxH)..... 157 x 237 x 327 mm (6.1 x 9.3 x 12.9 in.)  
Weight .....4.5 kg (9.9 lbs.)

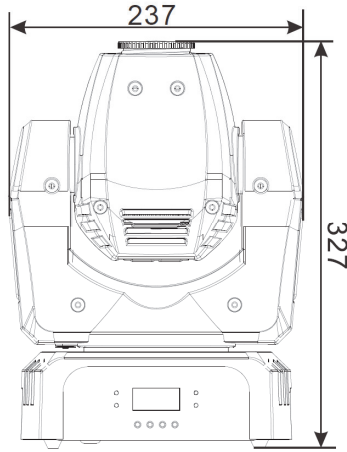
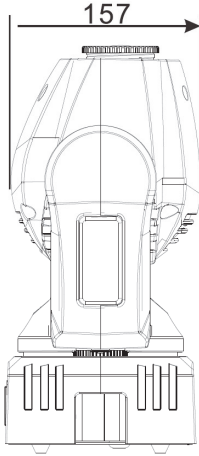

## Dynamic Effects

Color wheel..... 8 colors plus open, variable and random rotation  
Gobo wheel ..... 8 static gobos plus open, variable and random rotation  
Strobe ..... Variable from 3 - 20 Hz, pulse effects and random strobe  
Electronic dimming ..... 0 - 100%, four dimming curve options  
Pan ..... 540°  
Tilt..... 230°

## Optics

Light source ..... 18 W OSRAM LE UW Q8WP LED  
Minimum LED lifetime ..... 50 000 hours (to >70% luminous output)\*  
Beam angle ..... 14°  
Focus..... Manual

*\*Figure obtained under manufacturer's test conditions*

## Control and Programming

Control options ..... DMX, 4 stand-alone shows, master/slave  
DMX channels ..... 10  
Stand-alone trigger ..... Auto, music  
DMX compliance ..... USITT DMX512/1990  
Interface..... Control panel with backlit LCD display

## Construction

Color ..... Black  
Housing ..... High impact flame retardant thermoplastic  
IP rating ..... IP 20

## Installation

Mounting points ..... Bracket for rigging clamp  
Location ..... Dry location only, must be fastened to surface or structure  
Orientation ..... Vertical (head down if suspended)  
Minimum distance to illuminated surfaces ..... 200 mm (8 in.)  
Minimum distance to combustible materials ..... 100 mm (4 in.)  
Minimum clearance around fans and vents ..... 100 mm (4 in.)

## Connections

AC power input ..... IEC  
DMX data in/out ..... 3-pin & 5-pin locking XLR

## Electrical

AC power ..... 100-240 V nominal, 50/60 Hz  
Power supply unit ..... Auto-ranging electronic switch mode  
Fuse ..... T 2.0 A

## Typical power and current

120 V, 60 Hz ..... 52 W, 0.8 A  
230 V, 50 Hz ..... 50 W, 0.5 A  
Typical half-cycle RMS inrush current ..... 6.4 A

*Measurements made at nominal voltage with all LEDs at full intensity. Allow for a deviation of +/- 10%.*

## Thermal

Cooling ..... Forced air (temperature-regulated)  
Maximum ambient temperature ( $T_a$  max.) ..... 40° C (104° F)  
Minimum ambient temperature ( $T_a$  min.) ..... 0° C (32° F)  
Total heat dissipation\* ..... 180 BTU/hr.

*\*Calculated, +/- 10%, at full intensity, full white*

## Approvals



EU safety ..... EN 60598-2-17 (EN 60598-1), EN 62471, EN 62493  
EU EMC ..... EN 55015; EN 55032; EN 55103-1,-2; EN 61000-3-2,-3;  
EN 61000-4-2, -4, -5; EN 61547  
US safety ..... UL 1573  
US EMC ..... CFR Title 47 Part 15 Class A  
Canadian safety ..... CSA C22.2 No. 166

Canadian EMC ..... ICES-003 Class A  
Australia/NZ (pending) ..... RCM

**Included Items**

- Power cable, 1.9 m without mains plug
- Power cable, 1.9 m with US plug
- Bracket for rigging clamp attachment

**Accessories**

*Installation hardware*

- Half-coupler clamp ..... P/N 91602005
- G-clamp ..... P/N 91602003
- Quick-trigger clamp ..... P/N 91602007
- Safety cable, safe working load 50 kg..... P/N 91604003

**Related Items**

- RUSH™ Software Uploader 1 ..... P/N 91611399

**Ordering Information**

- RUSH™ MH 8 Mini Profile in cardboard box ..... P/N 90280110

*Specifications subject to change without notice. For latest product specifications, see [www.martin.com](http://www.martin.com)*

 	<p><b>Disposing of this product</b></p> <p>RUSH by Martin™ products are supplied in compliance with Directive 2012/19/EC of the European Parliament and of the Council of the European Union on WEEE (Waste Electrical and Electronic Equipment), where applicable. Help preserve the environment! Ensure that this product is recycled at the end of its life. Your supplier can give details of local arrangements for the disposal of RUSH by Martin products</p>
--	--



## Photobiological Safety Warning

The label shown below is displayed on this product. If it becomes difficult or impossible to read, it must be replaced using the illustration below to reproduce a new label sized 45 x 18 mm, in black on a yellow background.

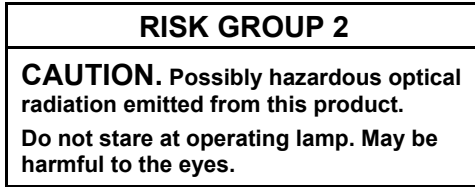





**Martin**<sup>®</sup>  
by HARMAN