



PAR56 Active 300W DMX

PAR

Musikhaus Thomann
Thomann GmbH
Hans-Thomann-Strasse 1
96138 Burgebrach
Germany
Telephone: +49 (0) 9546 9223-0
E-mail: info@thomann.de
Internet: www.thomann.de

16.12.2016, ID: 394815, 394816

Table of contents

1	General notes	5
	1.1 Further information.....	6
	1.2 Notational conventions.....	7
	1.3 Symbols and signal words.....	8
2	Safety instructions	11
3	Features	16
4	Installation	17
5	Starting up	20
6	Connections and controls	23
7	Operating	26
	7.1 Starting the device.....	26
	7.2 Main menu.....	26
	7.3 Menu overview.....	31
8	Maintenance	33
	8.1 Installing / replacing the illuminant.....	33

9	Technical specifications.....	37
10	Plug and connection assignments.....	38
11	Troubleshooting.....	39
12	Cleaning.....	41
13	Protecting the environment.....	42

1 General notes

This manual contains important instructions for the safe operation of the unit. Read and follow the safety instructions and all other instructions. Keep the manual for future reference. Make sure that it is available to all those using the device. If you sell the unit please make sure that the buyer also receives this manual.

Our products are subject to a process of continuous development. Thus, they are subject to change.

1.1 Further information

On our website (www.thomann.de) you will find lots of further information and details on the following points:

Download	This manual is also available as PDF file for you to download.
Keyword search	Use the search function in the electronic version to find the topics of interest for you quickly.
Online guides	Our online guides provide detailed information on technical basics and terms.
Personal consultation	For personal consultation please contact our technical hotline.
Service	If you have any problems with the device the customer service will gladly assist you.

1.2 Notational conventions

This manual uses the following notational conventions:

Letterings

The letterings for connectors and controls are marked by square brackets and italics.

Examples: *[VOLUME]* control, *[Mono]* button.

Displays

Texts and values displayed on the device are marked by quotation marks and italics.

Examples: *'24ch'*, *'OFF'*.

Instructions



The individual steps of an instruction are numbered consecutively. The result of a step is indented and highlighted by an arrow.



Example:

1. ▶ Switch on the device.
2. ▶ Press *[Auto]*.
 - ⇒ Automatic operation is started.
3. ▶ Switch off the device.

1.3 Symbols and signal words

In this section you will find an overview of the meaning of symbols and signal words that are used in this manual.

Signal word	Meaning
DANGER!	This combination of symbol and signal word indicates an immediate dangerous situation that will result in death or serious injury if it is not avoided.
WARNING!	This combination of symbol and signal word indicates a possible dangerous situation that can result in death or serious injury if it is not avoided.
NOTICE!	This combination of symbol and signal word indicates a possible dangerous situation that can result in material and environmental damage if it is not avoided.
Warning signs	Type of danger
	Warning – high-voltage.
	Warning – hot surface.

Warning signs	Type of danger
 A yellow triangular warning sign with a black border, depicting a crane hook lifting a rectangular load.	Warning – suspended load.
 A yellow triangular warning sign with a black border, featuring a large black exclamation mark.	Warning – danger zone.

2 Safety instructions

Intended use

This device is intended to be used as an illumination effect. The device is designed for professional use and is not suitable for use in households. Use the device only as described in this user manual. Any other use or use under other operating conditions is considered to be improper and may result in personal injury or property damage. No liability will be assumed for damages resulting from improper use.

This device may be used only by persons with sufficient physical, sensorial, and intellectual abilities and having corresponding knowledge and experience. Other persons may use this device only if they are supervised or instructed by a person who is responsible for their safety.

Safety



DANGER!

Danger for children

Ensure that plastic bags, packaging, etc. are disposed of properly and are not within reach of babies and young children. Choking hazard!

Ensure that children do not detach any small parts (e.g. knobs or the like) from the unit. They could swallow the pieces and choke!

Never let children unattended use electrical devices.



DANGER!

Electric shock caused by high voltages inside

Within the device there are areas where high voltages may be present.

Completely disconnect the device from the power supply before you open or remove covers. Mount all covers and attach them firmly before connecting the device again.

Do not use the device if covers, protectors or optical components are missing or damaged.



DANGER!

Electric shock caused by short-circuit

Do not modify the mains cable or the plug. Failure to do so could result in electric shock/death or fire. If in doubt, seek advice from a registered electrician.



WARNING!

Eye damage caused by high light intensity

Never look directly into the light source.



WARNING!

Risk of epileptic shock

Strobe lighting can trigger seizures in photosensitive epilepsy. Sensitive persons should avoid looking at strobe lights.



WARNING!

Risk of burns at the surface and inside of the device

The surface and the inner parts of the device can become very hot during operation.

After switching off the device wait for at least 15 minutes before you start any maintenance activities.



NOTICE!

Risk of fire

Do not block areas of ventilation. Do not install the device near any direct heat source. Keep the device away from naked flames.



NOTICE!

Operating conditions

This device has been designed for indoor use only. To prevent damage, never expose the device to any liquid or moisture. Avoid direct sunlight, heavy dirt, and strong vibrations.



NOTICE!

Power supply

Before connecting the device, ensure that the input voltage (AC outlet) matches the voltage rating of the device and that the AC outlet is protected by a residual current circuit breaker. Failure to do so could result in damage to the device and possibly injure the user.

Unplug the device before electrical storms occur and when it is unused for long periods of time to reduce the risk of electric shock or fire.

3 Features

The PAR spotlight is suitable for almost all applications, for example in clubs, bars, small stages and theatres. It is characterized by small size, solid construction also for use 'on tour' and enormous power.

Special features of the device:

- Suitable for "PAR56" illuminants with socket GX16D, maximum power consumption 300 W (not included)
- Control via DMX as well as buttons and display on the unit itself.
- Strobe and fade effect
- Master/slave mode
- Robust metal housing with colour filter holder and double bracket

4 Installation

Unpack and carefully check that there is no transportation damage before using the unit. Keep the equipment packaging. To fully protect the device against vibration, dust and moisture during transportation or storage use the original packaging or your own packaging material suitable for transport or storage, respectively.

You can install the device on the wall, ceiling or floor. A two-piece mounting bracket with locking screws is included in the package.



WARNING!

Risk of injury caused by falling objects

Make sure that the installation complies with the standards and rules that apply in your country. Always secure the device with a secondary safety attachment, such as a safety cable or a safety chain.



NOTICE!

Fire and overheating hazard

The distance between the light source and flammable materials must be greater than 12 m. The distance to non-flammable materials must be greater than 2 m.

Always ensure sufficient ventilation.

The ambient temperature must always be below 40 °C (104 °F).



NOTICE!

Use of stands

When mounting the device onto a stand, ensure that the stand is in a safe and stable position and that the weight of the device does not exceed the maximum permissible load capacity of the stand.



NOTICE!

Possible data transmission errors

For error-free operation make use of dedicated DMX cables and do not use ordinary microphone cables.

Never connect the DMX input or output to audio devices such as mixers or amplifiers.

5 Starting up

Create all connections while the device is off. Use the shortest possible high-quality cables for all connections. Take care when running the cables to prevent tripping hazards.

Connections in DMX mode

Connect the DMX input of the device to the DMX output of a DMX controller or another DMX device. Connect the output of the first DMX device to the input of the second one, and so on to form a daisy chain. Always ensure that the output of the last DMX device in the daisy chain is terminated with a resistor ($110\ \Omega$, $\frac{1}{4}\ \text{W}$).

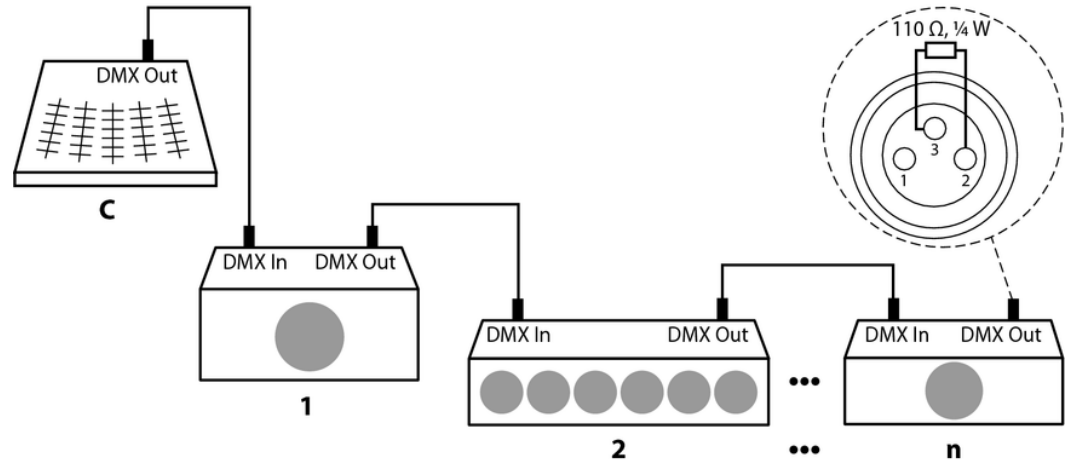

Connections in master/slave mode

When you configure a group of devices in master/slave mode, the first unit will control the other units for an automatic, sound-activated, synchronized show. This function is ideal when you want to start a show immediately. Connect the DMX output of the master device to the DMX input of the first slave device. Then connect the DMX output of the first slave device to the DMX input of the second slave device and so on.

6 Connections and controls

Rear panel

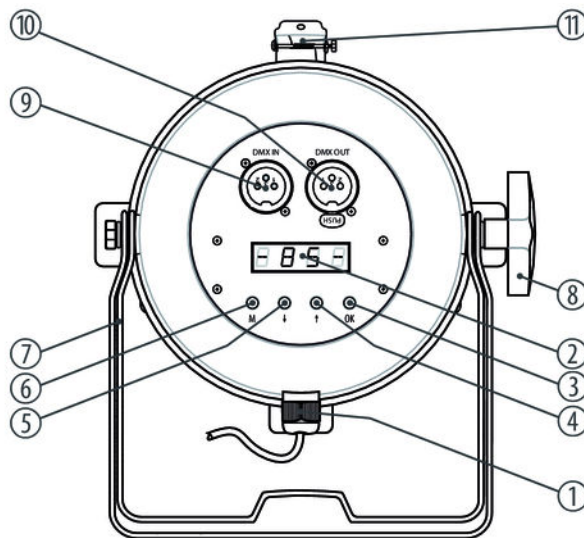

PAR56 Active 300W DMX

1	Power cord
2	Display
3	<i>[OK]</i> Confirms a selected value.
4,5	↑, ↓ Button to increase / decrease the displayed value by one.
6	<i>[M]</i> Calls the main menu or a submenu.
7	Two-piece bracket for floor placement or hanging.
8	Locking screw for the two-piece bracket.
9	<i>[DMX IN]</i> DMX input

10	<i>[DMX OUT]</i> DMX output
11	Knurled nut and screw to secure the housing.

7 Operating

7.1 Starting the device

Connect the device to the power supply to start operation. After a few seconds, the display indicates that a reset is in progress. The device is then ready for use.

7.2 Main menu

Press *[M]* to activate the main menu and select an operating mode. Use the arrow buttons to change the respectively displayed value. When the display shows the desired value press *[OK]*.

If you don't press any button for about 1 minute, the unit returns to the previously selected mode. The set values are retained even when the device is disconnected from the mains power supply.

DMX mode

Press *[M]*. Press one of the arrow buttons repeatedly until the display shows 'DMX' . Press *[OK]*. Press one of the arrow buttons repeatedly until the display shows 'MODE' . Press *[OK]*. Now use the arrow buttons to select one of the following DMX modes:

- '1CH' (one channel)

This setting is only relevant if the device is being controlled via DMX. When the display shows the desired value, press *[OK]* to confirm the selection and then *[M]* to return to the parent menu. To return to the parent menu without making changes, press *[M]*.

DMX address

Press *[M]*. Press one of the arrow buttons repeatedly until the display shows 'DMX' . Press *[OK]*. Press one of the arrow buttons repeatedly until the display shows 'ADDR' . Press *[OK]*. Now you can set the number of the first DMX channel used by the device (DMX address). Use the arrow buttons to select a value between 1 and 512. (Display shows 'A001' ... 'A512').

When the display shows the desired value, press *[OK]* to confirm the selection and then *[M]* to return to the parent menu. To return to the parent menu without making changes, press *[M]*.

Make sure this number matches the configuration of your DMX controller.

Display blackout

Press *[M]*. Press one of the arrow buttons repeatedly until the display shows 'DISP' . Press *[OK]*.

To enable the blackout function press one of the arrow buttons repeatedly until the display shows 'OFF' . Press *[OK]*. From now on the display goes out if you do not press a button within a period of two minutes. Once you press any button, the display becomes active again.

To permanently turn on the display, press one of the arrow buttons repeatedly until the display shows 'ON' . Press *[OK]*.

To return to the parent menu, press *[M]*.

'Master' operating mode

Press *[M]*. Press one of the arrow buttons repeatedly until the display shows 'MASL' . Press *[OK]*. Press one of the arrow buttons repeatedly until the display shows '-MA-' . To configure the device as a master, use the arrow buttons to select 'ON' . Press *[OK]*. The device is now configured as master and sets the movements and light effects which are copied by the devices configured as Slaves.

To return to the parent menu without making changes, press *[M]*.

Operating mode 'Slave'

To configure the device as slave, press one of the arrow buttons repeatedly until the display shows 'SLAVE'. Press [OK] to confirm the selection. Press [OK]. Press one of the arrow buttons repeatedly until the display shows '-SL-'. Press [OK].

Now you can set the number of the device with which it is addressed by the master as a slave. Use the arrow buttons to select a value between 1 and 512. (Display shows 'A001' ... 'A512'). Press [OK]. The device is now configured as a slave.

To return to the parent menu without making changes, press [M].

This setting is only relevant if the device is operating as Slave controlled by a Master, but not via DMX.

Brightness

Press [M]. Press one of the arrow buttons repeatedly until the display shows 'DIMM'. Press [OK]. You can now set the brightness. Use the arrow buttons to select a value between 0 (dark, 'D000') and 100 (full brightness, 'D100').

This setting takes effect only when the device is not operated under DMX control. When the display shows the desired value, press [OK] to confirm the selection and then [M] to return to the parent menu. To return to the parent menu without making changes, press [M].

Strobe effect

Press *[M]*. Press one of the arrow buttons repeatedly until the display shows 'STRO' . Press *[OK]*.

Press one of the arrow buttons repeatedly until the display shows 'LIGH' . Press *[OK]*. You can now set the brightness. Use the arrow buttons to select a value between 0 (dark, 'L000') and 100 (full brightness, 'L100'). Press *[OK]* and then *[M]*to return to the parent menu.

Press one of the arrow buttons repeatedly until the display shows 'SPEE' . Press *[OK]*. Now you can adjust the speed of the strobe effect. Use the arrow buttons to select a value between 'S-01' (slow) and 'S-10' (fast). Press *[OK]* and then *[M]*to return to the parent menu.

Fade effect

Press *[M]*. Press one of the arrow buttons repeatedly until the display shows 'FADE' . Press *[OK]*.

Press one of the arrow buttons repeatedly until the display shows 'MODE' . Press *[OK]*. You can now set the fade mode. Use the arrow keys to select either 'M-01' (gradually brightening and darkening), 'M-02' (gradual brightening and abrupt darkening) and 'M-03' (abrupt brightening and gradual darkening). Press *[OK]* and then *[M]*to return to the parent menu.

Press one of the arrow buttons repeatedly until the display shows 'SPEE' . Press *[OK]*. Now you can adjust the speed of the fade effect. Use the arrow buttons to select a value between 'S-01' (slow) and 'S-10' (fast). Press *[OK]* and then *[M]*to return to the parent menu.

7.3 Menu overview

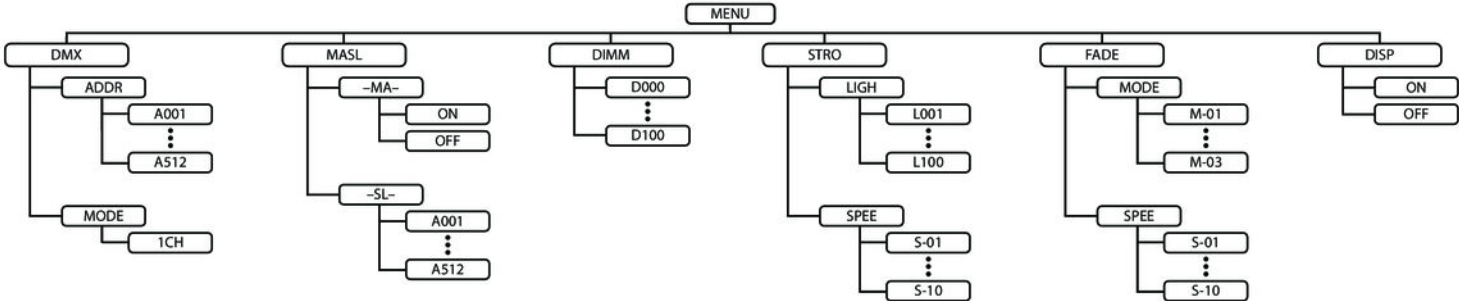

7.3.1 Functions in 1-channel DMX mode

Channel	Value	Function
1	0...255	Dimmer (0 % to 100 %)

8 Maintenance

8.1 Installing / replacing the illuminant

**DANGER!****Electric shock caused by high voltages inside**

Within the device there are areas where high voltages may be present.

Completely disconnect the device from the power supply before you open or remove covers. Mount all covers and attach them firmly before connecting the device again.

Do not use the device if covers, protectors or optical components are missing or damaged.



WARNING!

Risk of burns at the surface and inside of the device

The surface and the inner parts of the device can become very hot during operation.

After switching off the device wait for at least 15 minutes before you start any maintenance activities.



NOTICE!

Possible damages due to dirt or finger prints

Due to the high temperatures, even smallest pieces of dirt on the bulb can destroy the lamp when it is turned on.

Do not touch the lamp directly with your fingers. Use clean gloves or a clean lint-free tissue.

**NOTICE!****Possible damages due to wrong type of lamp**

Any attempt to use the device with a lamp other than those specified in this manual can result in severe damages to the device.

Only use a lamp of the specified type.

Notes on the illuminant

The device may only be operated with an illuminant of the type 'PAR56' with socket GX16D, maximum power consumption 300 W, for use in the stage and theatre area. Observe the safety instructions of the illuminant manufacturer.

Procedure

- 1.** ➤ Make sure that the device is turned off, disconnected from the mains and completely cooled down.
- 2.** ➤ Move the head of the unit in a horizontal position. The knurled nut which holds the two halves of the housing must be at the top.

- 3.** ▶ Loosen the knurled nut and pull it together with the screw out of the housing against the resistance of the spring. This enables the rear half of the housing to be separated from the front half.
Be careful not to unscrew the knurled nut completely.
- 4.** ▶ Press the two ends of the mounting ring together and remove it. Remove the illuminant from the holder.
- 5.** ▶ Remove the connector from the old illuminant.
- 6.** ▶ Attach the connector to the new illuminant.
- 7.** ▶ Place the new illuminant on the circular ledge in the front half of the housing. Press the two ends of the mounting ring together and slide it firmly onto the illuminant. Check the secure fit.
- 8.** ▶ Place the rear half of the housing on the front half so that the centring pin of the rear half (below the power cable) slides into the designated hole in the front half.
Tighten the knurled nut and the screw against the spring resistance and push the screw into the recess on the front half of the housing.
- 9.** ▶ Check the correct fit of the two housing halves and tighten the knurled nut securely.

9 Technical specifications

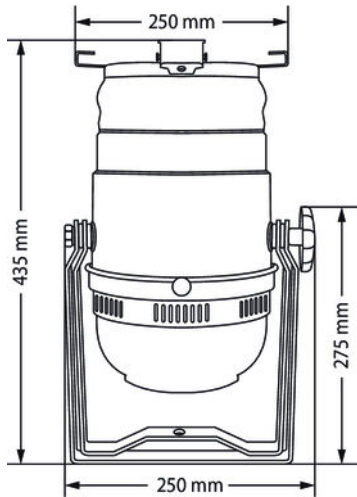

Light source	'PAR56' with socket GX16D, maximum power consumption 300 W
Beam angle	40°
Number of DMX channels	1
Power consumption	depends on the illuminant used
Operating supply voltage	100 – 240 V ~ 50/60 Hz
Housing colour	Black (item no. 394815) Silver (item no. 394816)
Dimensions (W × H × D)	250 × 250 × 435 mm

10 Plug and connection assignments

Introduction

This chapter will help you select the right cables and plugs to connect your valuable equipment so that a perfect light experience is guaranteed.

Please take our tips, because especially in 'Sound & Light' caution is indicated: Even if a plug fits into a socket, the result of an incorrect connection may be a destroyed DMX controller, a short circuit or 'just' a not working light show!

DMX connections

The unit offers a 3-pin XLR socket for DMX output and a 3-pin XLR plug for DMX input. Please refer to the drawing and table below for the pin assignment of a suitable XLR plug.



Pin	Configuration
1	Ground, shielding
2	Signal inverted (DMX-, 'cold signal')
3	Signal (DMX+, 'hot signal')

11 Troubleshooting



NOTICE!

Possible data transmission errors

For error-free operation make use of dedicated DMX cables and do not use ordinary microphone cables.

Never connect the DMX input or output to audio devices such as mixers or amplifiers.

In the following we list a few common problems that may occur during operation. We give you some suggestions for easy troubleshooting:

Symptom	Remedy
Device not working, no light	Check the mains connection and the main fuse.
Apparently no function despite proper power supply	Check if the unit is in DMX mode or in 'slave' mode. If so, check the unit in another mode.
No response to the DMX controller	<ol style="list-style-type: none">1. Check that the DMX controller is switched on. Check the DMX connectors and cables for correct connection.2. Check the address settings and the DMX polarity.3. Try using another DMX controller.4. Check to see if the DMX cables run near or alongside to high voltage cables that may cause damage or interference to DMX interface circuits.

If the procedures recommended above do not succeed, please contact our Service Center. You can find the contact information at www.thomann.de.

12 Cleaning

Optical lenses

Clean the optical lenses, that are accessible from the outside, regularly in order to optimize the light output. The frequency of cleaning depends on the operating environment: wet, smoky or particularly dirty surroundings can cause more accumulation of dirt on the optics of the device.

- Clean with a soft cloth using our lamp and lens cleaner (item no. 280122).
- Always dry the parts carefully.

Fan grids

The fan grids of the device must be cleaned on a regular basis to remove dust and dirt. Before cleaning, switch off the device and disconnect AC-powered devices from the mains. Use a lint-free damp cloth for cleaning. Never use solvents or alcohol for cleaning.

13 Protecting the environment

Disposal of the packaging material



For the transport and protective packaging, environmentally friendly materials have been chosen that can be supplied to normal recycling.

Ensure that plastic bags, packaging, etc. are properly disposed of.

Do not just dispose of these materials with your normal household waste, but make sure that they are collected for recycling. Please follow the notes and markings on the packaging.

Disposal of your old device



This product is subject to the European Waste Electrical and Electronic Equipment Directive (WEEE). Do not dispose with your normal household waste.

Dispose of this device through an approved waste disposal firm or through your local waste facility. When discarding the device, comply with the rules and regulations that apply in your country. If in doubt, consult your local waste disposal facility.



Musikhaus Thomann · Hans-Thomann-Straße 1 · 96138 Burgebrach · Germany · www.thomann.de