

ignition

Manual

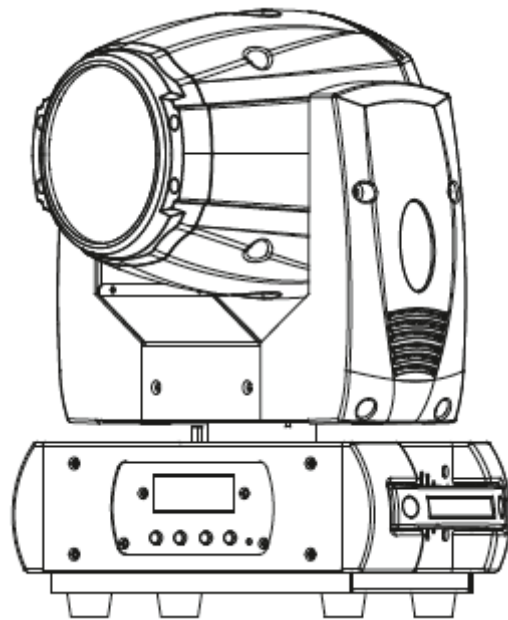

LED Compact Beam CB-50

Table of contents

1. Safety instructions	3
1.1. For safe and efficient operation	3
2. Designated use	4
2.1. Overhead installation	5
3. Introduction.....	7
3.1. Dimensions	7
4. Connections	8
4.1. Electrical connections.....	8
4.2. DMX connections	8
4.3. DMX connection with terminator.....	8
5. Control.....	9
5.1. Structure of the menu	9
6. DMX chart	11
6.1. DMX mode Standard (11 channels).....	11
6.2. DMX Modus Basic (9 channels)	13
7. Photometrical data	16
8. Color wheel	16
9. Gobo wheel	16
10. Technical data	17

1. Safety instructions



- This device is suitable for indoor use (not outdoors) only.
- All modifications to the device will void the warranty.
- Repairs are to carry out by skilled personnel only.
- Use only fuses of the same type and original parts as spare parts.
- Protect the unit from rain and humidity to avoid fire and electric shocks.
- Make sure to unplug the power supply before opening the housing.

1.1. For safe and efficient operation

Be careful with heat and extreme temperature

Avoid exposing it to direct rays of the sun or near a heating appliance.
Not put it in a temperature bellow 32°F /0°C, or exceeding 104°F /40°C.

Keep away from humidity, water and dust

Do not place the set in a location with high humidity or lots of dust.
Containers with water should not be placed on the set.

To avoid placing on un-stable location

Select a level and stable location to avoid vibration.

Do not use chemicals or volatile liquids for cleaning

Use a clean dry cloth to wipe off the dust, or a wet soft cloth for stubborn dirt.

If out of work, contact sales agency immediately

Any troubles arose, remove the power plug soon, and contact with an engineer for repairing, do not open the cabinet by yourself, it might result a danger of electric shock.

Take care with the power cable

Never pull the power cable to remove the plug from the receptacle, be sure to hold the plug. When not using the device for an extended period of time, be sure to disconnect the plug from the receptacle.

Important:

Damages caused by the disregard of this user manual are not subject to warranty. The dealer will not accept liability for any resulting defects or problems. Make sure the electrical connection is carried out by qualified personnel. All electrical and mechanical connections have to be carried out according to the European safety standards.

2. Designated use

This device was developed for professional use on stages, in discos, theatres etc. The device is only approved for a connection up to 230V 50/60 Hz AC voltage and only for indoor use.

Regular breaks during operation increase the lifetime of your device.

Avoid convulsions or any form of forceful impact during the installation or the start-up of the device.

Make sure that the device is not exposed excessive heat, humidity or dust at the place of installation. Take care that no cables are lying around. You would endanger your own safety and also the safety of a third party.

It is not allowed to operate or store the device in an environment in which spray water, rain, humidity or fog is expected. Humidity or very high atmospheric humidity could reduce the isolation of the device and could cause deathly electric shocks. If you use fog devices the device has not be exposed to a direct smoke jet. There has to be a safety distance of at least 0,5m between this device and the fog machine. Make sure that the saturation of the fog has to enable a visibility of at least 10m.

Operate the device not during thunderstorms. Surge voltages could destroy the device. Unplug the power supply during thunderstorms.

During the installation the use of the mounting bracket is obligatory.

Surrounding objects or surfaces should not be in contact with the device. And make sure that there is a distance of at least 0,2m between the lenses and illuminated objects.

Make sure that during the installation and removal of the device the area below the place of installation is basically cordoned off. This also applies to implementation of service.

The device has basically been protected by a suitable safety.

Make familiar yourself with the functions of the device before start-up. People without the experience should not handle with the device. The most cause of functional disorder is inappropriate handling.

Do not use chemicals or volatile liquids for cleaning. Use a clean dry cloth to wipe off the dust, or a wet soft cloth for stubborn dirt.

For transport use the original packing or designated accessory to avoid damages during the transport.

For reasons of safety unauthorized changes are forbidden.

A usage of the device which differs from usages which are described in this manual can cause damages of the device. In that case the warranty expires. Additional you should notice that every differed usage is related with dangers and can cause e.g. an electrical short, fire, electric shock or crash.

2.1. Overhead installation



Danger of life!

You have to observe the regulations of BGV C1 (formerly VBG 70) and EN60598-2-17 Installations are to carry out by skilled personnel only.

The suspension devices have to be build and measured so they can withstand for an hour the tenfold of the payload without suffering a permanent detrimental deformation.

Basically installation has to be made by using a second separate suspension. This can be e.g. a suitable net. The second suspension must be designed and attached so no part of the installation can fall down in case of failure.

During construction, reconstruction and deconstruction unnecessary stay in the range of moving areas, on lightning bridges, under elevated work stations or any other danger zones is forbidden.

The operator is obliged to following safety-related and mechanical facilities:

- Before the first start-up or after critical changes before restarting it has to be checked by an expert.
- Review in the frame of the inspection test at least all four years by an expert. .
- Review by a qualified person at least once a year.

How to carry out the overhead installation:

In tidal fall you should install the device out of the lounge area of people

IMPORTANT! Overhead installation requires a high level of experience. This includes knowledge of calculating the payload, used installation material and safety inspections of the used material and the projector whereas the required experience is not limited to this. Do not try to carry out installation yourself under any circumstances if you are not qualified. Contact a professional installer. An inappropriate installation can lead to injuries and/or damaged properties.

It is not allowed to install the device in the grip area of people.

If the device may hang from the ceiling or from high beams, the use of truss systems is mandatory. The device may not be installed so it can swing freely in the room.

Please note: Crashing down items can cause serious injuries! Do not install the projector, if you doubt the safety of a possible installation form!

Before installation make sure that the mounting surface has the ability to carry the tenfold point load of the own weight of the device.

Mount the device with the mounting-bracket to your trussing system using an appropriate clamp.

During overhead installation the device must be always secured by a safety rope which is designed to hold the twelvefold weight of device. Only safety ropes with quick-release safety fastener elements may be used. Hang up the safety rope in the hole of the mounting bracket. Direct the rope over the truss or an appropriate fastening point. Hang up the end in the fastening element and tie up the locking nut. A safety rope once exposed to failing load or damaged may not be used furthermore.

The maximum drop exceed must not exceed 20cm.

A safety rope once exposed to failing load or damaged may not be used furthermore.
Adjust the desired inclination angle via the mounting bracket and tighten the screw.

3. Introduction

Thank you for buying the **LED Compact Beam CB-50**. It is a powerful device. For a successful installation and operation, please read this manual carefully.

3.1. Dimensions

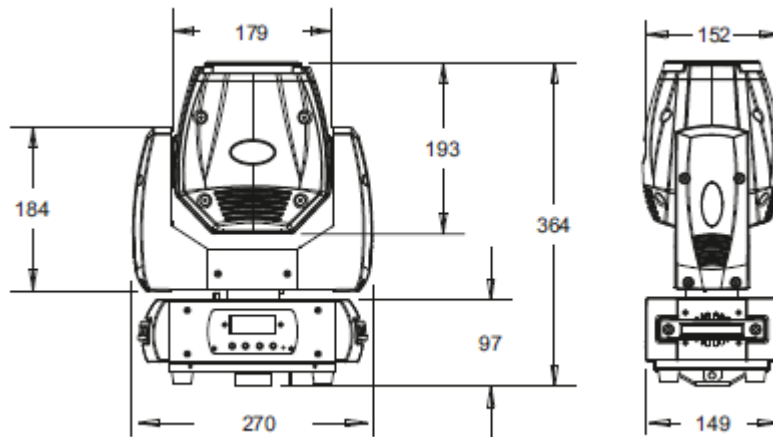

4. Connections

4.1. Electrical connections

If you wish to change the power supply settings, see the chapter Appendix. Connect the fixture to the mains with the enclosed power cable and plug. The earth has to be connected.

Cable (EU)	Cable (US)	Pin	International
Brown	Black	Live	L
Light blue	White	Neutral	N
Yellow/Green	Green	Earth	⊕

4.2. DMX connections

To make a DMX512 connection go ahead like it is described in the picture. Make sure that you use shielded cable. 3pole or 5pole XLR cables are suitable.

Important! After the last device the line has to be terminated. In order to do this you have to solder a 120Ω resistor between the pins Data + and Data -. You can solder this end resistor on a 3pin or 5pin XLR: Plug this adapter into the DMX output of the device.

4.3. DMX connection with terminator

Where the DMX cable has to run a long distance or the equipment is operated in an electrically noisy environment like a disco for installations, we recommend using a DMX terminator. This prevents corruption of the digital control signal by electrical noise. The DMX terminator is simply an XLR connector with a 120 Ω resistor between pins 2 and 3, which is then plugged into the XLR output socket of the last device in the series. Please look to the bottom drawings.

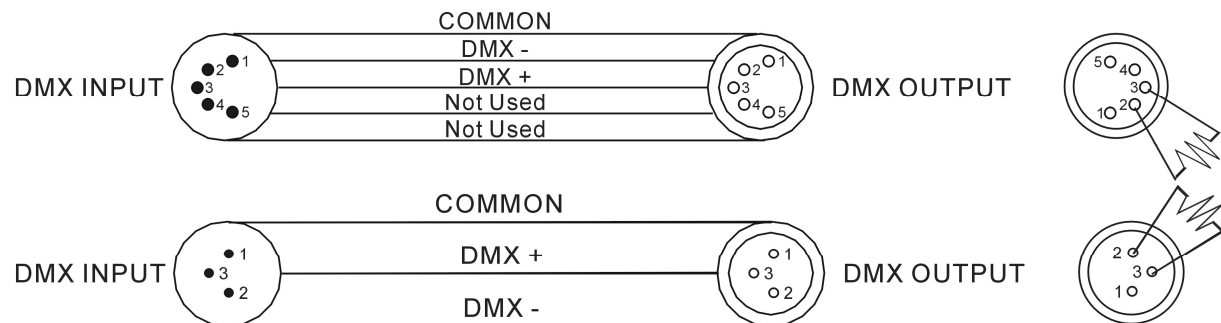

5. Control

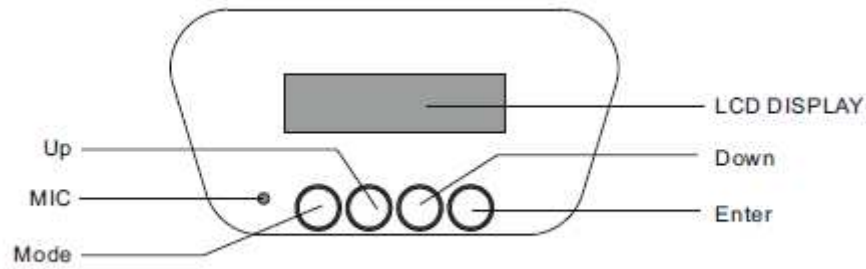

Press MODE to get to the menu. With UP/DOWN you can select the required point of menu. Confirm your selection with ENTER. With UP/DOWN you can make your settings after this confirm your settings with ENTER.

5.1. Structure of the menu

Menu	Submenu 1	Submenu 2	Submenu 3	Function
DMX Address	A001 – A512			Setting the DMX address.
Auto Play	Auto Program	Master / Alone		Choosing the run mode and (de-)activating the Master-Slave mode.
	Music Control			
Reset	ALL Reset			Reset of all motors.
	Scan Reset			Reset the scan function.
	Color Reset			Reset the colors.
	GOBO Reset			Reset the gobos.
	Dimmer Reset			Reset the dimmer and the strobe.
	Other Reset			Reset of all other functions.
Reverse Pan	On / Off			(De-)Activates the inverted Pan.
Reverse Tilt	On / Off			(De-)Activates the inverted Tilt.
Mic sensitivity	0 – 99%			Setting the sensitivity of the microphone.
Special	Reset Default	On / Off		Reset to default.
	Calibration	PAN		Calibrates the respective function. For this you need to enter a password (008).
		TILT		
		Color Wheel		
		Gobo Wheel		
	Prism			
	Temperature			Shows the current temperature.
	Manual Control			Manual control of all functions.
Signal Set	Wire DMX			Wired DMX.
	Wireless DMX			Wireless DMX

		Act WDMX & Out		Input Wireless DMX and output wired DMX.
Edit Program	Auto	Program1 – Program8	Steps 1 - Steps48	Here you can create a customer program.
			Scenes01 – Scenes XX	
Mode of channel	Standard Mode			Choosing a DMX mode.
	Basic Mode			
Select Degree	PAN Degree	630		Pan 630°
		540		Pan 540°
		360		Pan 360°
	TILT Degree	270		Tilt 270°
		180		Tilt 180°
		90		Tilt 90°
Version				Shows the current software version.

6. DMX chart

6.1. DMX mode Standard (11 channels)

Channel	Value from	Value to	Function
1	0	255	Pan
2	0	255	Pan fine
3	0	255	Tilt
4	0	255	Tilt fine
5	0	7	White
	8	15	Color 1
	16	23	Color 2
	24	31	Color 3
	32	39	Color 4
	40	47	Color 5
	48	55	Color 6
	56	63	Color 7
	64	71	Color 8
	72	79	Color 9
	80	87	Color 10
	88	95	Color 11
	96	103	Color 12
	104	111	Color 13
	112	127	Color 14
	128	189	Color change clockwise fast – slow
190	193	Stop	
194	255	Color change counter clockwise slow – fast	
6	0	4	Open
	5	9	Gobo 1
	10	14	Gobo 2
	15	19	Gobo 3
	20	24	Gobo 4
	25	29	Gobo 5
	30	34	Gobo 6
	35	39	Gobo 7
	40	44	Gobo 8
	45	49	Gobo 9
	50	54	Gobo 10
	55	59	Gobo 11
	60	64	Gobo 12
	65	69	Gobo 13
	70	74	Gobo 14
	75	79	Gobo 15
	80	84	Gobo 16
85	89	Gobo 17	
90	97	Gobo 1 Shake slow - fast	

	98	105	Gobo 2 Shake slow - fast
	106	113	Gobo 3 Shake slow - fast
	114	121	Gobo 4 Shake slow - fast
	122	129	Gobo 5 Shake slow - fast
	130	137	Gobo 6 Shake slow - fast
	138	145	Gobo 7 Shake slow - fast
	146	153	Gobo 8 Shake slow - fast
	154	161	Gobo 9 Shake slow - fast
	162	169	Gobo 10 Shake slow - fast
	170	177	Gobo 11 Shake slow - fast
	178	185	Gobo 12 Shake slow - fast
	186	193	Gobo 13 Shake slow - fast
	194	201	Gobo 14 Shake slow - fast
	202	209	Gobo 15 Shake slow - fast
	210	217	Gobo 16 Shake slow - fast
	218	225	Gobo 17 Shake slow - fast
	226	255	Rotation Gobo wheel slow – fast
7	0	31	Shutter closed
	32	63	Shutter open
	64	95	Strobe slow – fast
	96	127	Shutter open
	128	159	Pulse effect slow – fast
	160	191	Shutter open
	192	223	Strobe (Random) slow – fast
	224	255	Shutter open
8	0	255	Dimmer
9	0	5	No function
	6	127	Prism
	128	255	Rotation Prism slow – fast
10	0	225	Pan / Tilt speed fast – slow
	226	235	Blackout while movements.
	236	245	Blackout while movements of color and gobo wheel.
	246	255	No function
11	0	79	No function
	80	84	Reset of all motors
	85	87	#Reset scan motor
	88	90	Reset color motor
	91	93	Reset gobo wheel motor
	94	96	Reset dimmer and strobe motor
	97	99	Reset of all other motors
	100	119	Automatic program 1
	120	139	Automatic program 2
	140	159	Automatic program 3
	160	179	Automatic program 4
180	199	Automatic program 5	

	200	219	Automatic program 6
	220	239	Automatic program 7
	240	255	Sound-to-light mode

6.2. DMX Modus Basic (9 channels)

Channel	Value	Value to	Function
1	0	255	Pan
2	0	255	Tilt
3	0	7	White
	8	15	Color 1
	16	23	Color 2
	24	31	Color 3
	32	39	Color 4
	40	47	Color 5
	48	55	Color 6
	56	63	Color 7
	64	71	Color 8
	72	79	Color 9
	80	87	Color 10
	88	95	Color 11
	96	103	Color 12
	104	111	Color 13
	112	127	Color 14
	128	189	Color change clockwise fast – slow
	190	193	Stop
194	255	Color change counter clockwise slow – fast	
4	0	4	Open
	5	9	Gobo 1
	10	14	Gobo 2
	15	19	Gobo 3
	20	24	Gobo 4
	25	29	Gobo 5
	30	34	Gobo 6
	35	39	Gobo 7
	40	44	Gobo 8
	45	49	Gobo 9
	50	54	Gobo 10
	55	59	Gobo 11
	60	64	Gobo 12
	65	69	Gobo 13
	70	74	Gobo 14
	75	79	Gobo 15
	80	84	Gobo 16
85	89	Gobo 17	

	90	97	Gobo 1 Shake slow - fast
	98	105	Gobo 2 Shake slow - fast
	106	113	Gobo 3 Shake slow - fast
	114	121	Gobo 4 Shake slow - fast
	122	129	Gobo 5 Shake slow - fast
	130	137	Gobo 6 Shake slow - fast
	138	145	Gobo 7 Shake slow - fast
	146	153	Gobo 8 Shake slow - fast
	154	161	Gobo 9 Shake slow - fast
	162	169	Gobo 10 Shake slow - fast
	170	177	Gobo 11 Shake slow - fast
	178	185	Gobo 12 Shake slow - fast
	186	193	Gobo 13 Shake slow - fast
	194	201	Gobo 14 Shake slow - fast
	202	209	Gobo 15 Shake slow - fast
	210	217	Gobo 16 Shake slow - fast
	218	225	Gobo 17 Shake slow - fast
226	255	Rotation Gobo wheel slow – fast	
5	0	31	Shutter closed
	32	63	Shutter open
	64	95	Strobe slow – fast
	96	127	Shutter open
	128	159	Pulse effect slow – fast
	160	191	Shutter open
	192	223	Strobe (Random) slow – fast
	224	255	Shutter open
6	0	255	Dimmer
7	0	5	No function
	6	127	Prism
	128	255	Rotation Prism slow – fast
8	0	225	Pan / Tilt speed fast – slow
	226	235	Blackout while movements.
	236	245	Blackout while movements of color and gobo wheel.
	246	255	No function
9	0	79	No function
	80	84	Reset of all motors
	85	87	#Reset scan motor
	88	90	Reset color motor
	91	93	Reset gobo wheel motor
	94	96	Reset dimmer and strobe motor
	97	99	Reset of all other motors
	100	119	Automatic program 1
	120	139	Automatic program 2
	140	159	Automatic program 3
160	179	Automatic program 4	

	180	199	Automatic program 5
	200	219	Automatic program 6
	220	239	Automatic program 7
	240	255	Sound-to-light mode

7. Photometrical data

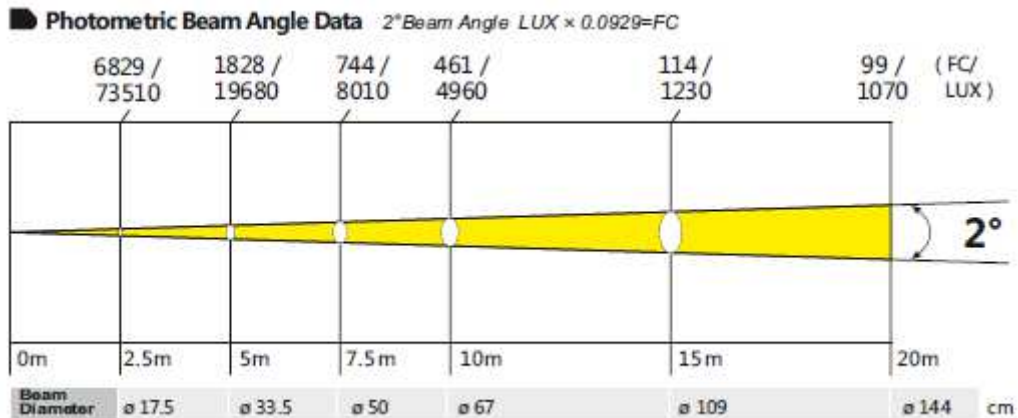

8. Color wheel



9. Gobo wheel

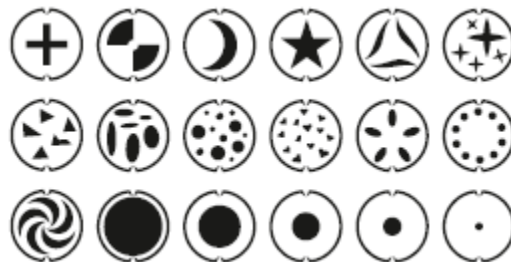

10. Technical data

Power supply	
Voltage	90 – 260 V AC / 50-60 Hz
Power consumption max.	55 W
Light source	
LM type	LED single color
Color spectrum	7500 K
Power	50 W
Number / Power	1x 50 W
Optics	
Beam angle	2°
Prism	3-way
Connections	
Power in	P-Con
XLR in/out	3pol
Functions	
Pan	360° / 540° / 630°
Tilt	90° / 180° / 270°
Gobo wheel 1	18-way, static
Color wheel	14 Colors + white
Controlling	
Sound-to-Light	Yes
Automatic	Yes
Master-Slave	Yes
DMX512	Yes
Number of channels	9 / 11 channels
Hardware	
Protection class	IP20
Suitability	Indoor
Dimensions (L/B/H)	270 x 149 x 364 mm
Weight	5,8 kg

Importer:

B & K Braun GmbH
Industriestraße 2
D-76307 Karlsbad
www.bkbraun.com
info@bkbraun.com

