

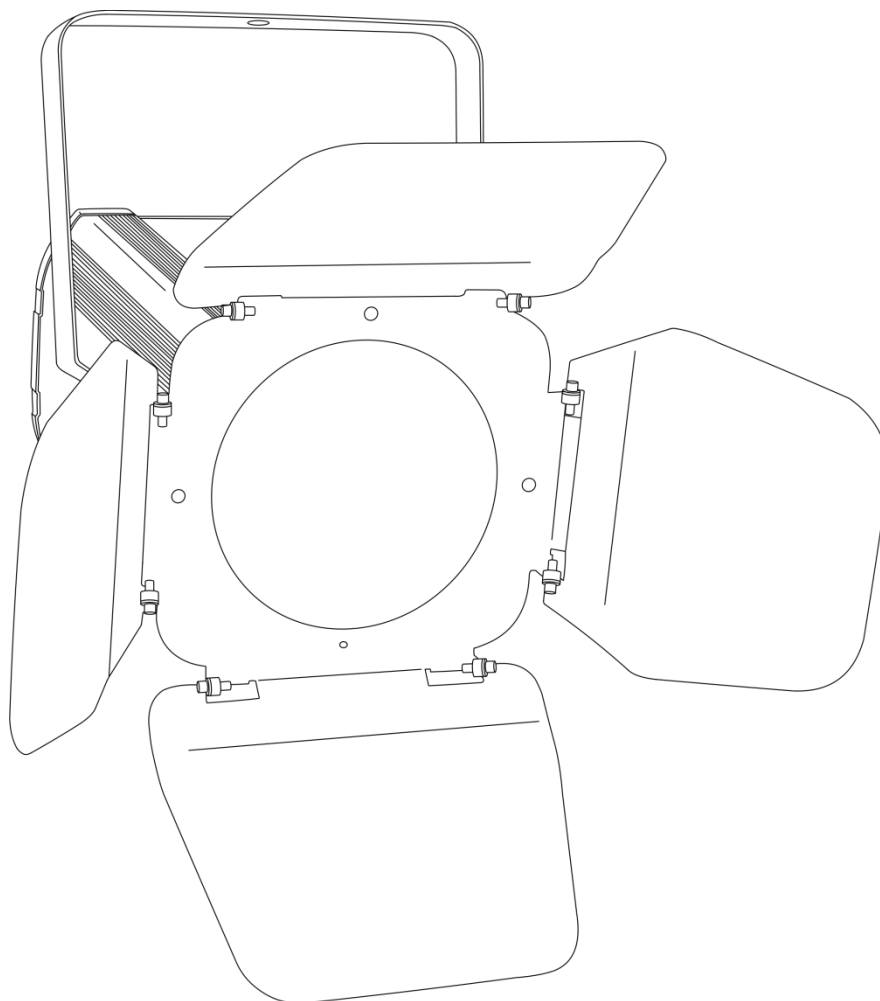

**MANUAL**



**ENGLISH**

**Performer 60 LED**

**V1**

**Ordercode: 33100**

**Table of contents**

|  |    |
|--|----|
| <b>Warning</b> .....                             | 2  |
| Safety Instructions .....                        | 2  |
| Operating Determinations .....                   | 4  |
| Rigging .....                                    | 4  |
| Connection with the mains .....                  | 5  |
| Return Procedure .....                           | 6  |
| Claims .....                                     | 6  |
| <b>Description of the device</b> .....           | 7  |
| Features .....                                   | 7  |
| Overview .....                                   | 7  |
| Backside .....                                   | 8  |
| <b>Installation</b> .....                        | 9  |
| <b>Set Up and Operation</b> .....                | 9  |
| Color frame retaining clip .....                 | 9  |
| Control Modes .....                              | 10 |
| One Performer (Auto mode and Dimmer mode) .....  | 10 |
| One Performer (Sound-controlled) .....           | 10 |
| Multiple Performers (Master/Slave control) ..... | 10 |
| Multiple Performers (DMX Control) .....          | 11 |
| Fixture Linking .....                            | 12 |
| Data Cabling .....                               | 12 |
| Control Panel .....                              | 13 |
| Control Mode .....                               | 13 |
| DMX Addressing .....                             | 13 |
| Menu Overview .....                              | 14 |
| Main Menu Options .....                          | 14 |
| 1. Auto Mode .....                               | 15 |
| 2. Dimmer Mode .....                             | 15 |
| 3. Sound-controlled mode .....                   | 15 |
| 4. Master/Slave mode .....                       | 15 |
| 5. DMX-512 mode .....                            | 16 |
| DMX Channels .....                               | 16 |
| 1 Channel .....                                  | 16 |
| 3 Channels .....                                 | 16 |
| <b>Maintenance</b> .....                         | 17 |
| Replacing the Fuse .....                         | 17 |
| <b>Troubleshooting</b> .....                     | 18 |
| No Light .....                                   | 18 |
| No Response to DMX .....                         | 18 |
| <b>Product Specifications</b> .....              | 20 |
| <b>Dimensions</b> .....                          | 21 |
| <b>Notes</b> .....                               | 22 |

## Warning



**For your own safety, please read this user manual carefully  
before your initial start-up!**



## Unpacking Instructions

Immediately upon receiving this product, carefully unpack the carton and check the contents to ensure that all parts are present, and have been received in good condition. Notify the dealer immediately and retain packing material for inspection if any parts appear damaged from shipping or the carton itself shows signs of mishandling. Save the carton and all packing materials. In the event that a fixture must be returned to the factory, it is important that the fixture be returned in the original factory box and packing.

### Your shipment includes:

- Showtec Performer 60 LED
- 1 x Filterframe
- Powercon to Schuko power cable (1,5m)
- User manual

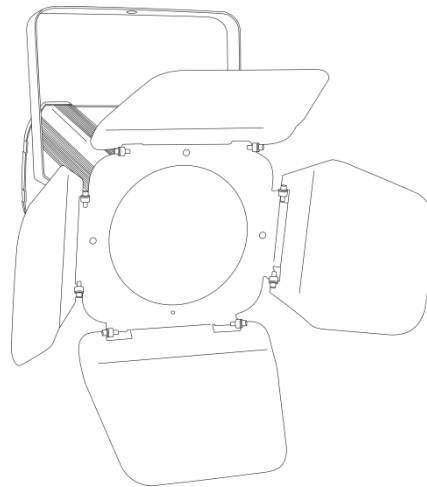

## LED Expected Lifespan

LEDs gradually decline in brightness over time. HEAT is the dominant factor that leads to the acceleration of this decline. Packaged in clusters, LEDs exhibit higher operating temperatures than in ideal or singular optimum conditions. For this reason, when all color LEDs are used at their fullest intensity, life of the LEDs is significantly reduced. If improving the lifespan is of higher priority, place care in providing for lower operational temperatures. This may include climatic-environmental and the reduction of overall projection intensity.



### **CAUTION!**

**Keep this device away from rain and moisture!  
Unplug mains lead before opening the housing!**



## Safety Instructions

Every person involved with the installation, operation and maintenance of this device has to:

- be qualified
- follow the instructions of this manual



**CAUTION! Be careful with your operations.  
With a dangerous voltage you can suffer  
a dangerous electric shock when touching the wires!**



Before the initial start-up, please make sure that there is no damage caused by transportation. Should there be any, consult your dealer and do not use the device.

To maintain perfect condition and to ensure a safe operation, it is absolutely necessary for the user to follow the safety instructions and warning notes contained in this manual.

Please consider that damages caused by manual modifications to the device are not subject to warranty.

This device contains no user-serviceable parts. Refer servicing to qualified technicians only.

### **IMPORTANT:**

The manufacturer will not accept liability for any resulting damages caused by the non-observance of this manual or any unauthorized modification to the device.

- Never let the power cord come into contact with other cables! Handle the power cord and all connections with the mains with particular caution!
- Never remove warning or informative labels from the unit.
- Never use anything to cover the ground contact.
- Never lift the fixture holding it by the projector-head, as the mechanics may be damaged. Always hold the fixture by the transport handles.
- Never place any material over the lens.
- Never look directly into the light source.
- Never leave any cables lying around.
- Never loosen the screws of the rotating gobo otherwise you risk opening of the ball bearing.
- Do not insert objects into air vents.
- Do not connect this device to a dimmerpack.
- Do not switch the device on and off in short intervals, as this will reduce the device's life.
- Do not touch the device's housing bare-handed during its operation (housing becomes very hot). Allow the fixture to cool for at least 5 minutes before handling.
- Do not shake the device. Avoid brute force when installing or operating the device.
- Only use the device indoors, avoid contact with water or other liquids.
- Only operate the fixture after having checked if the housing is firmly closed and all screws are tightly fastened.
- Only operate the device after having familiarized with its functions.
- Avoid flames and do not put close to flammable liquids or gases.
- Always keep the case closed while operating.
- Always allow a free air space of at least 50 cm around the unit for ventilation.
- Always disconnect power from the mains, when device is not used or before cleaning! Only handle the power cord holding it by the plug. Never pull out the plug by tugging the power cord.
- Make sure that the device is not exposed to extreme heat, moisture or dust.
- Make sure that the available voltage is not higher than stated on the rear panel.
- Make sure that the power cord is never crimped or damaged. Check the device and the power cord from time to time.
- If the lens is obviously damaged, it has to be replaced.
- If device was dropped or struck, disconnect mains power supply immediately. Have a qualified engineer inspect for safety before operating.
- If the device has been exposed to drastic temperature fluctuation (e.g. after transportation), do not switch it on immediately. The arising condensation water might damage your device. Leave the device switched off until it has reached room temperature.
- If your Showtec device fails to work properly, discontinue the use immediately. Pack the unit securely (preferably in the original packing material), and return it to your Showtec dealer for service.
- For adult use only. Never leave the unit running unattended.
- Never attempt to bypass the thermostatic switch or fuses.
- For replacement use fuses of same type and rating only.

- The user is responsible for correct positioning and operating of the Performer. The manufacturer will not accept liability for damages caused by the misuse or incorrect installation of this device.
- This device falls under protection class I. Therefore it is essential to connect the yellow/green conductor to earth.
- During the initial start-up some smoke or smell may arise. This is a normal process and does not necessarily mean that the device is defective.
- Repairs, servicing and electric connection must be carried out by a qualified technician.
- WARRANTY: Till one year after date of purchase.

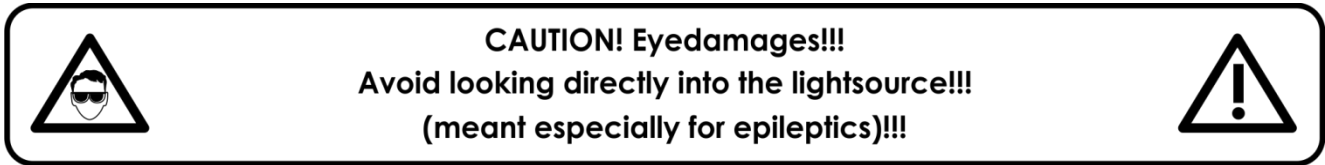

### Operating Determinations

- This device is not designed for permanent operation. Consistent operation breaks will ensure that the device will serve you for a long time without defects.
- The minimum distance between light output and the illuminated surface must be bigger than 1 meter.
- The maximum ambient temperature  $t_a = 40^\circ\text{C}$  must never be exceeded.
- The relative humidity must not exceed 50 % with an ambient temperature of  $40^\circ\text{C}$ .
- If this device is operated in any other way than the one described in this manual, the product may suffer damages and the warranty becomes void.
- Any other operation may lead to dangers like short-circuit, burns, electric shock, crash, etc.

*You endanger your own safety and the safety of others!*

### Rigging

Please follow the European and national guidelines concerning rigging, trussing and all other safety issues.

Do not attempt the installation yourself !

Always let the installation be carried out by an authorized dealer !

### Procedure:

- If the projector is lowered from the ceiling or high joists, professional trussing systems have to be used.
- Use a clamp to mount the projector, with the mounting bracket, to the trussing system.
- The projector must never be fixed swinging freely in the room.
- The installation must always be secured with a safety attachment, e.g. an appropriate safety net or safety cable.
- When rigging, derigging or servicing the projector, always make sure, that the area below the installation site is secured and that there are not any unauthorized people around.

Improper installation can cause serious injuries and/or damage of property!

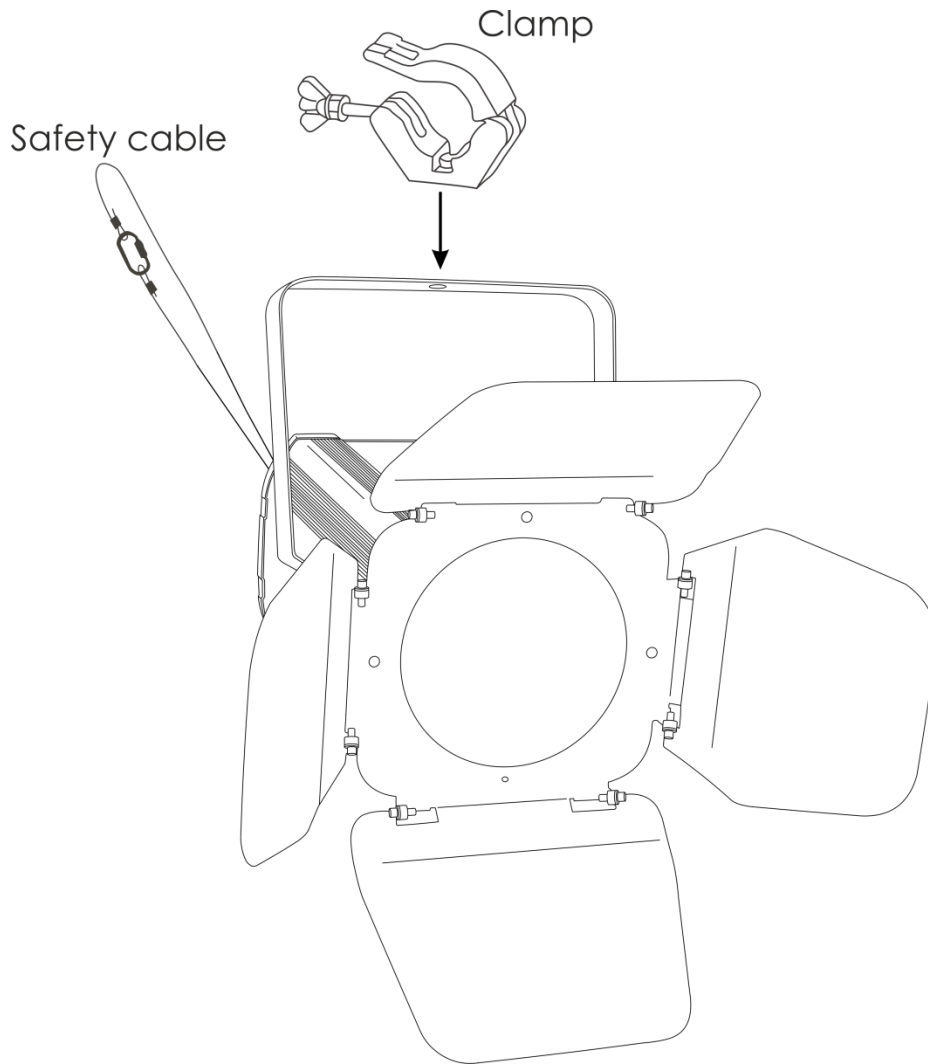

**Connection with the mains**

Connect the device to the mains with the power-plug.  
 Always check if the right color cable is connected to the right place.

| International | EU Cable     | UK Cable | US Cable      | Pin               |
|---------------|--------------|----------|---------------|-------------------|
| L             | BROWN        | RED      | YELLOW/COPPER | PHASE             |
| N             | BLUE         | BLACK    | SILVER        | NEUTRAL           |
| ⊕             | YELLOW/GREEN | GREEN    | GREEN         | PROTECTIVE GROUND |

*Make sure that the device is always properly connected to the earth!*

*Improper installation can cause serious injuries and/or damage of property!*



### **Return Procedure**

Returned merchandise must be sent prepaid and in the original packing, call tags will not be issued. Package must be clearly labeled with a Return Authorization Number (RMA number). Products returned without an RMA number will be refused. Highlite will not accept the returned goods or any responsibility. Call Highlite 0031-455667723 or mail [offersales@highlite.nl](mailto:offersales@highlite.nl) and request an RMA prior to shipping the fixture. Be prepared to provide the model number, serial number and a brief description of the cause for the return. Be sure to properly pack fixture, any shipping damage resulting from inadequate packaging is the customer's responsibility. Highlite reserves the right to use its own discretion to repair or replace product(s). As a suggestion, proper UPS packing or double-boxing is always a safe method to use.

**Note: If you are given an RMA number, please include the following information on a piece of paper inside the box:**

- 01) Your name
- 02) Your address
- 03) Your phone number
- 04) A brief description of the symptoms

### **Claims**

The client has the obligation to check the delivered goods immediately upon delivery for any shortcomings and/or visible defects, or perform this check after our announcement that the goods are at their disposal. Damage incurred in shipping is the responsibility of the shipper; therefore the damage must be reported to the carrier upon receipt of merchandise.

It is the customer's responsibility to report and submit claims with the shipper in the event that a fixture is damaged due to shipping. Transportation damage has to be reported to us within one day after receipt of the delivery.

Any return shipment has to be made post-paid at all times. Return shipments must be accompanied with a letter defining the reason for return shipment. Non-prepaid return shipments will be refused, unless agreed otherwise in writing.

Complaints against us must be prepared in writing or sent by fax within 10 working days after receipt of the invoice. After this period complaints will not be handled anymore.

Complaints will only then be considered if the client has so far complied with all parts of the agreement, regardless of the agreement from which the obligation is resulting.

## Description of the device

### Features

The Showtec Performer 60 LED is a powerful light fixture with high output and great effects.

- Light Source: 1 x 60W COB
- Input Voltage: 100-240VAC, 60/50Hz
- Power Consumption: 75W
- Light output: 3500 lumen
- Color Temperature: 3200K
- Dimmer: 0-100%
- Strobe: 0-20Hz
- Beam Angle: 8-45°
- Control modes: Auto, Dimmer, Sound-controlled, Master/Slave, DMX-512
- LCD display for easy setup
- Connections: 3-pin XLR signal connectors IN/OUT, PowerCon power connectors IN/OUT
- DMX channels: 1 or 3 channels
- Housing: Die-cast aluminum & flame retardant plastic
- Cooling: Forced cooling
- IP Rating: IP20
- Fuse: T1L/250V
- Dimensions: 485 x 450 x 300 mm (LxWxH)
- Weight: 4,8 kg

### Overview

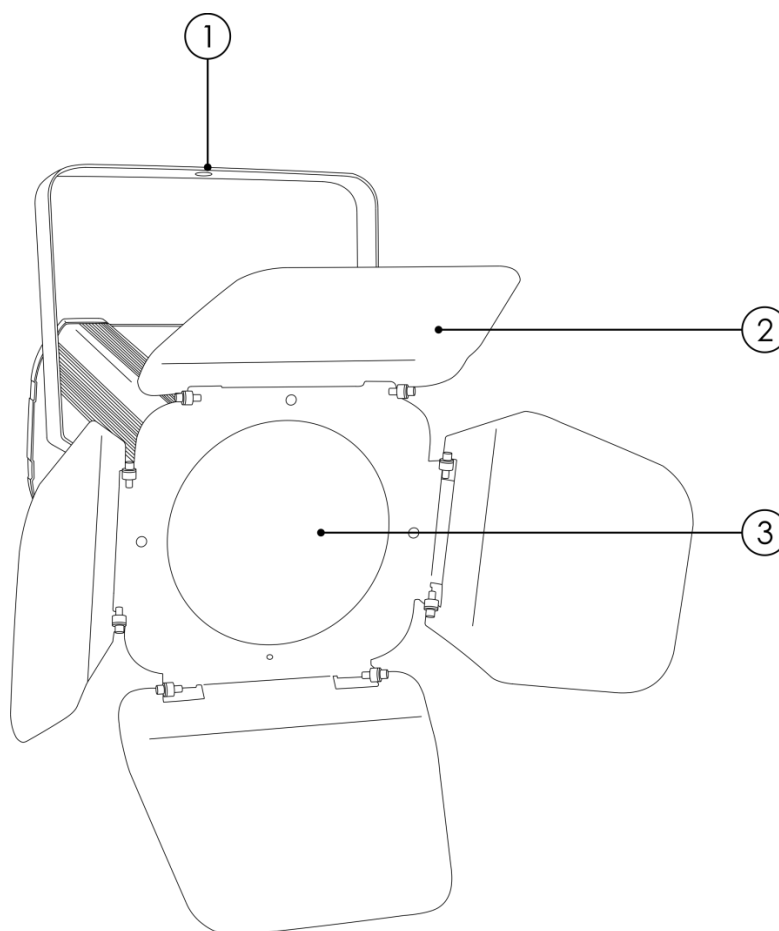

Fig. 01

- 01) Mounting bracket with inclination screw  
02) Barn door  
03) 1 x 60W COB LED



Backside

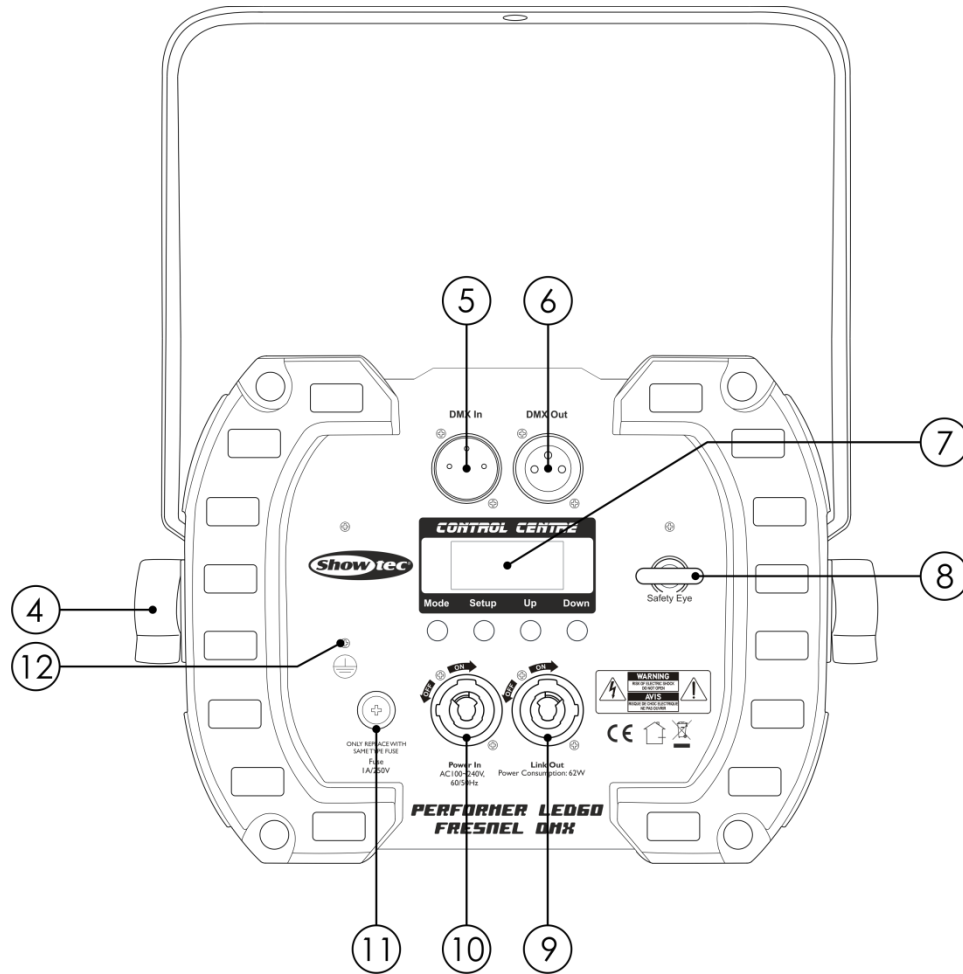

Fig. 02

- 04) Adjustment screw
- 05) 3-pin DMX signal connector IN
- 06) 3-pin DMX signal connector OUT
- 07) LCD display + menu buttons
- 08) Safety eye
- 09) Powercon power connector 100-240V OUT
- 10) Powercon power connector 100-240V IN
- 11) Fuse T1L/250V
- 12) Ground/earth connection

## Installation

Remove all packing materials from the Performer 60 LED. Check if all foam and plastic padding is removed. Connect all cables.

**Do not supply power before the whole system is set up and connected properly.**

**Always disconnect from electric mains power supply before cleaning or servicing.**

**Damages caused by non-observance are not subject to warranty.**

## Set Up and Operation

Follow the directions below, as they pertain to your preferred operation mode.

Before plugging the unit in, always make sure that the power supply matches the product specification voltage. Do not attempt to operate a 120V specification product on 230V power, or vice versa.

Connect the device to the main power supply.

### Color frame retaining clip

The color frame holder is equipped with a spring-loaded retaining clip. This prevents color frames and accessories from falling out.



**Make sure that all color frame accessories are locked in position with the retaining clip before hanging the Performer 60 LED.**



- 01) Press the retaining clip down, in order to unlock the color frame slot.
- 02) Insert the color frame(s).
- 03) Lock the retaining clip by releasing the retaining clip.

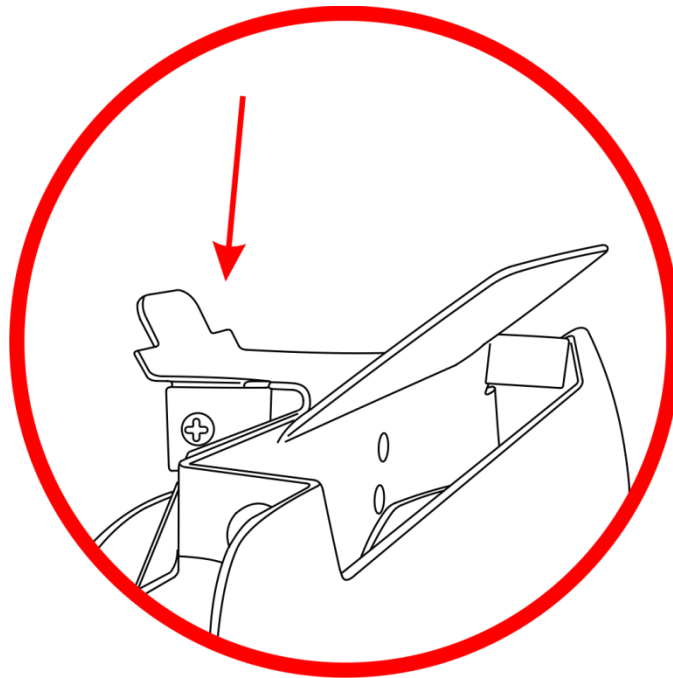

Fig. 03

## Control Modes

There are 5 modes:

- Auto mode
- Dimmer mode
- Sound-controlled mode
- Master/Slave
- DMX-512 (1CH, 3CH)

### One Performer (Auto mode and Dimmer mode)

- 01) Fasten the effect light to a firm trussing. Leave at least 0,5 meter on all sides for air circulation.
- 02) Plug the end of the electric mains power cord into a proper electric power supply socket.
- 03) When the Performer is not connected with a DMX cable, it functions as a stand-alone device. Please see page 15 for more information.

### One Performer (Sound-controlled)

- 01) Fasten the effect light to a firm trussing. Leave at least 0,5 meter on all sides for air circulation.
- 02) Plug the end of the electric mains power cord into a proper electric power supply socket.
- 03) Turn on the music. The Performer will react to the beat of the music. Please see page 15 for more information about the sound-control options.

### Multiple Performers (Master/Slave control)

- 01) Fasten the effect light onto firm trussing. Leave at least 0,5 meter on all sides for air circulation.
- 02) Use a 3-pin XLR cable to connect the Performer.

The pins:



- 01) Earth
- 02) Signal -
- 03) Signal +

- 03) Link the units as shown in fig. 04. Connect the first unit's DMX "out" socket with the second unit's "in" socket, using a DMX-signal cable. Repeat this process to link the second, third, and fourth units. You can use the same functions on the master device as described on page 15. This means that you can set your desired operation mode on the master device and all slave devices will react the same as the master device.

### Multiple Performers (Master/Slave control)

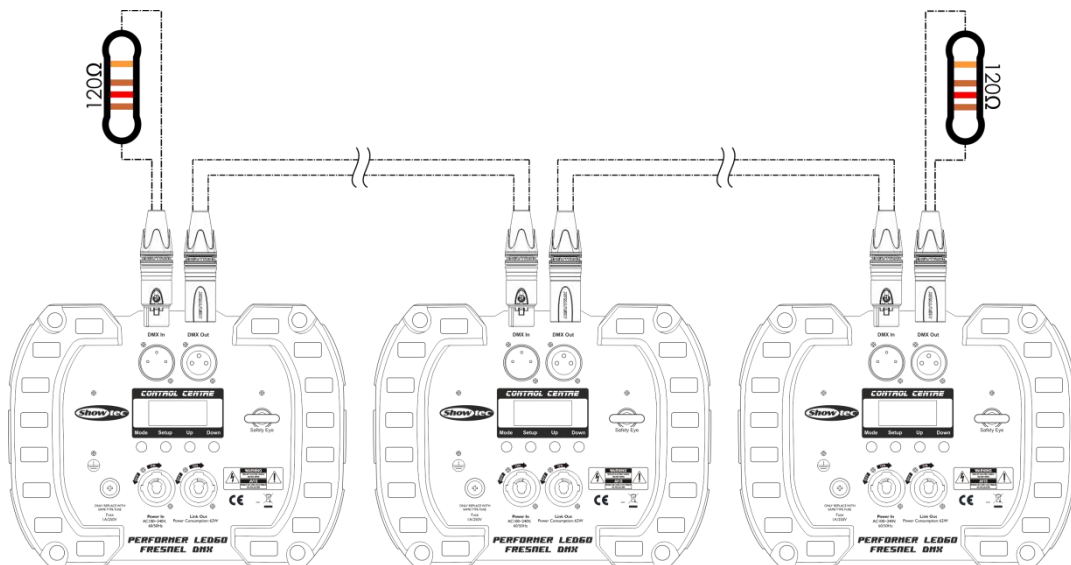
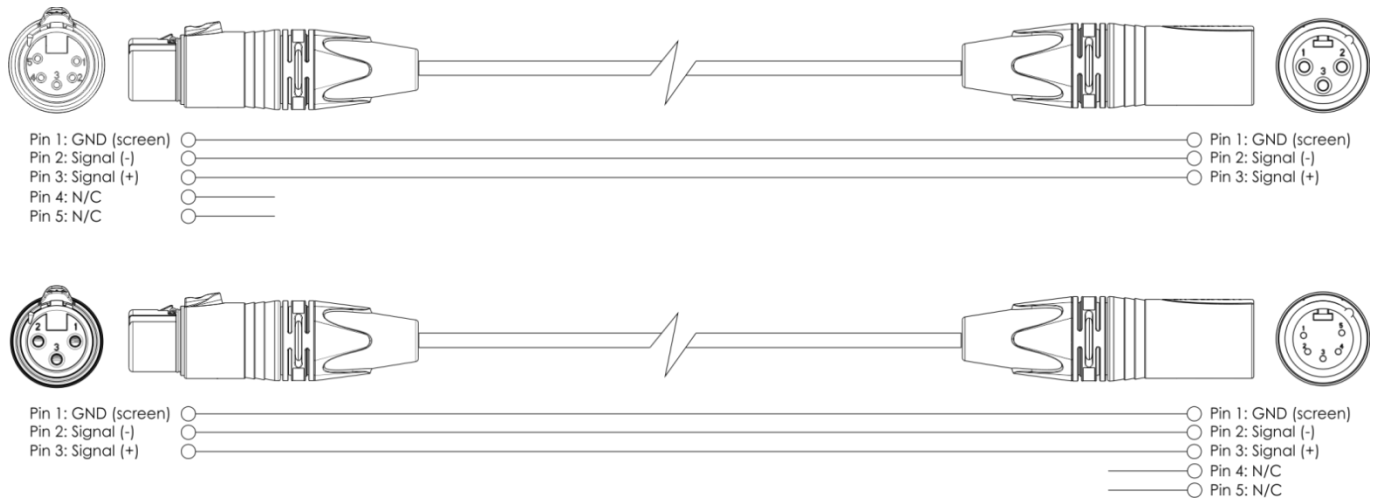

Fig. 04

## Multiple Performers (DMX Control)

- 01) Fasten the effect light to a firm trussing. Leave at least 0,5 meter on all sides for air circulation.
- 02) Always use a safety cable (ordercode 70140 / 70141).
- 03) Use a 3-pin XLR cable to connect the Performers and other devices.



- 04) Link the units as shown in fig. 05. Connect the first unit's DMX "out" socket with the second unit's "in" socket, using a DMX-signal cable. Repeat this process to link the second, third, and fourth units.
- 05) Supply electric power: Plug electric mains power cords into each unit's IEC socket, then plug the other end of the mains power cord into proper electric power supply sockets, starting with the first unit. Do not supply power before the whole system is set up and connected properly.

## Multiple Performers DMX Set Up

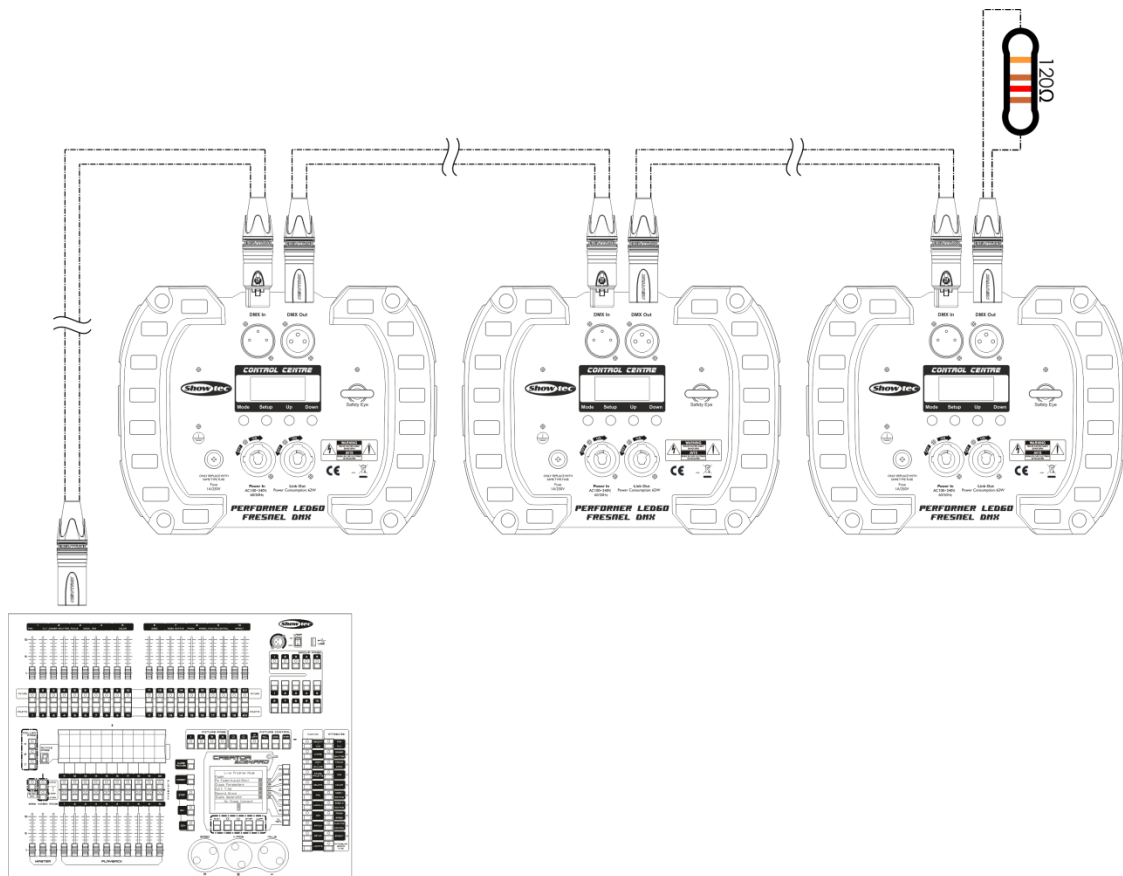



Fig. 05

Note : Link all cables before connecting electric power

## Fixture Linking

You will need a serial data link to run light shows of one or more fixtures using a DMX-512 controller or to run synchronized shows of two or more fixtures set to a master/slave operating mode. The combined number of channels required by all the fixtures on a serial data link determines the number of fixtures the data link can support.

- Important:** Fixtures on a serial data link must be daisy-chained in a single line. To comply with the EIA-485 standard, no more than 30 devices should be connected on one data link. Connecting more than 30 fixtures on one serial data link without the use of a DMX optically isolated splitter may result in deterioration of the digital DMX signal.
- 
- Maximum recommended DMX data link distance: 100 meters
  - Maximum recommended number of fixtures on a DMX data link: 30 fixtures
  - Maximum recommended number of fixtures on a DMX powerlink: 5 fixtures @ 110V
  - Maximum recommended number of fixtures on a DMX powerlink: 10 fixtures @ 240V

## Data Cabling

To link fixtures together, you must obtain data cables. You can purchase DAP Audio certified DMX cables directly from a dealer/distributor or construct your own cable. If you choose to create your own cable, please use data-grade cables that can carry a high quality signal and are less prone to electromagnetic interference.

### DAP Audio Certified DMX Data Cables

- DAP Audio Basic microphone cable for allround use. bal. XLR/M 3 p. > XLR/F 3 p.  
**Ordercode** FL01150 (1,5m.), FL013 (3m.), FL016 (6m.), FL0110 (10m.), FL0115 (15m.), FL0120 (20m).
- DAP Audio cable for the demanding user with exceptional audio-qualities and connector made by Neutrik®. **Ordercode** FL71150 (1,5m.), FL713 (3m.), FL716 (6m.), FL7110 (10m.).

The Performer 60 LED can be operated with a controller in **control mode** or without the controller in **stand-alone mode**.

## Control Panel

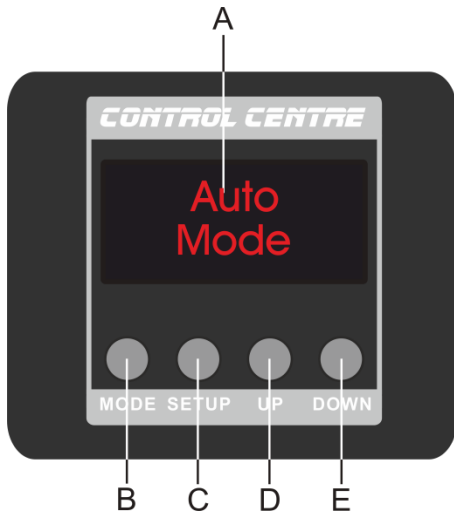

- A) MENU button
- B) MODE button
- C) SETUP button
- D) UP button
- E) DOWN control

Fig. 06

## Control Mode

The fixtures are individually addressed on a data-link and connected to the controller. The fixtures respond to the DMX signal from the controller. (When you select the DMX address and save it, the controller will display the saved DMX address, next time.)

## DMX Addressing

The control panel on the front side of the base allows you to assign DMX fixture addresses, which is the first channel with which the Performer will respond to the controller.

Please note, when you use the controller, the unit has **3** channels.

When using multiple Performers, make sure you set the DMX addresses right.

Therefore, the DMX address of the first Performer should be **1(001)**; the DMX address of the second Performer should be **1+3=4 (004)**; the DMX address of the third Performer should be **4+3=7 (007)**, etc.

Please, make sure that you do not have any overlapping channels in order to control each Performer correctly. If two or more Performers are addressed similarly, they will work similarly.

## Controlling:

After having addressed all Performer fixtures, you may now start operating these via your lighting controller.

**Note:** After switching on, the Performer will automatically detect whether DMX 512 data is received or not. If there is no data received at the DMX-input, the "LED" on the control panel will not flash.

If not, the problem may be:

- The XLR cable from the controller is not connected with the input of the Performer 60 LED.
- The controller is switched off or defective, the cable or connector is defective, or the signal wires are swapped in the input connector.

**Note:** It is necessary to insert an XLR termination plug (with 120 Ohm) in the last fixture in order to ensure proper transmission on the DMX data link.

## Display Off after 10 seconds

When no button is pressed for 10 seconds, the display will turn off.

To light up the display, you have to press the MENU, SETUP, UP or DOWN button.

Once you have pressed the button, the display will light up.

Menu Overview

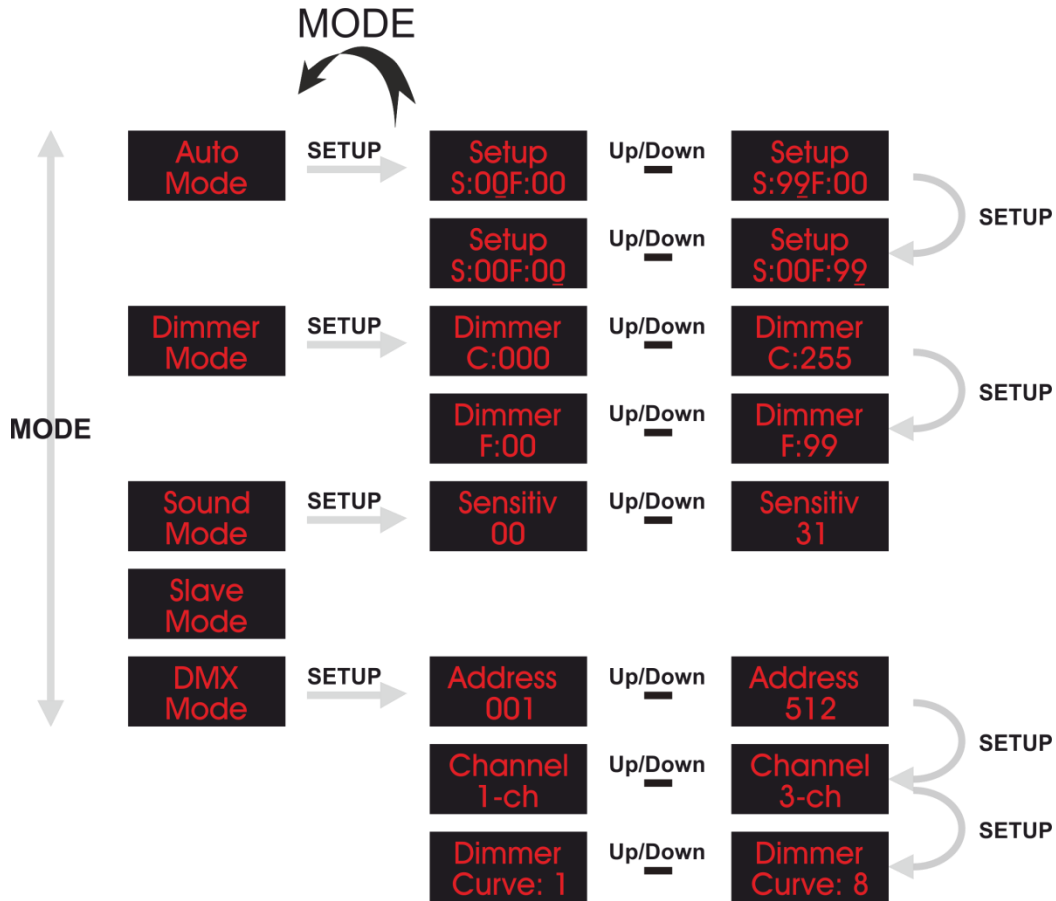





Main Menu Options

- Auto Mode**      Auto mode
- Dimmer Mode**      Dimmer mode
- Sound Mode**      Sound-controlled mode
- Slave Mode**      Master/Slave mode
- DMX Mode**      DMX-512 mode



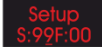
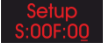







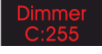

## 1. Auto Mode

In this mode, you can set the strobe effect.

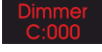
- 01) Press the **MODE** button until the display shows .
- 02) Press the **SETUP** button to enter the menu.
- 03) Press the **UP/DOWN** buttons to increase/decrease the strobe intensity. The adjustment range is between   , from OFF to fast.
- 04) Press the **SETUP** button again, to enter the strobe frequency settings.
- 05) Press the **UP/DOWN** buttons to increase/decrease the strobe frequency. The adjustment range is between   , from low to high frequency.





## 2. Dimmer Mode

In this mode, you can set the dimmer settings.

- 01) Press the **MODE** button until the display shows .
- 02) Press the **SETUP** button to enter the menu.
- 03) Press the **SETUP** button to toggle between the following 2 options:  
   Dimmer brightness  
  
   Strobe frequency
- 04) When the display shows   , press the **UP/DOWN** buttons to increase/decrease the dimmer brightness. The adjustment range is between 000-255, from dark to brightest.
- 05) When the display shows   , press the **UP/DOWN** buttons to increase/decrease the strobe frequency. The adjustment range is between 00-99, from OFF to high frequency.

## 3. Sound-controlled mode

In this mode, you can set the sound sensitivity of the device.

- 01) Press the **MODE** button until the display shows .
- 02) Press the **UP/DOWN** buttons to increase/decrease the sound sensitivity. The adjustment range is between   , from OFF to high sound sensitivity.

## 4. Master/Slave mode









In this mode, you can set the Performer as a slave device.

- 01) Press the **MODE** button until the display shows .
- 02) The device is now operating in the slave mode. It means that it will react the same as the master device.



## 5. DMX-512 mode

In this mode, you can set the DMX address and the channel mode.

- 01) Press the **MODE** button until the display shows .
- 02) Press the **UP/DOWN** buttons to set the desired DMX address. The adjustment range is between   .
- 03) Press the **SETUP** button to enter the channel mode menu.
- 04) Press the **UP/DOWN** buttons to choose one of the 2 channel modes:  
 1-channel mode  
  
 3-channel mode
- 05) Press the **SETUP** button to enter the dimming curve settings.
- 06) Press the **UP/DOWN** buttons to choose the desired dimming curve pattern. The adjustment range is between   .

## DMX Channels

### 1 Channel

#### Channel 1 – Dimmer

0-255 Gradual dimmer adjustment, 0-100%

### 3 Channels

#### Channel 1 – Dimmer

0-255 Gradual dimmer adjustment, 0-100%

#### Channel 2 – Control modes

0-10 Strobe

11-255 Sound-controlled mode

#### Channel 3 – Strobe CH2 must be set between 0-10

0-255 Strobe frequency, from OFF to high frequency

#### Channel 3 – Sound sensitivity CH2 must be set between 11-255

0-255 Sound sensitivity, from OFF to high sensitivity

## Maintenance

---

The operator has to make sure that safety-related and machine-technical installations are to be inspected by an expert after every year in the course of an acceptance test.

The operator has to make sure that safety-related and machine-technical installations are to be inspected by a skilled person once a year.

The following points have to be considered during the inspection:

- 01) All screws used for installing the device or parts of the device have to be tightly connected and must not be corroded.
- 02) There may not be any deformations on housings, fixations and installation spots.
- 03) Mechanically moving parts like axles, eyes and others may not show any traces of wearing.
- 04) The electric power supply cables must not show any damages or material fatigue.

The Performer 60 LED requires almost no maintenance. However, you should keep the unit clean.

Otherwise, the fixture's light-output will be significantly reduced. Disconnect the mains power supply, and then wipe the cover with a damp cloth. Do not immerse in liquid. Wipe lens clean with glass cleaner and a soft cloth. Do not use alcohol or solvents.

The front lens will require weekly cleaning, as smoke-fluid tends to build up residues, reducing the light-output very quickly.

Please clean internal components once a year with a light brush and vacuum cleaner.

Keep connections clean. Disconnect electric power, and then wipe the DMX and audio connections with a damp cloth. Make sure connections are thoroughly dry before linking equipment or supplying electric power.

## Replacing the Fuse

Power surges, short-circuit or inappropriate electrical power supply may cause a fuse to burn out. If the fuse burns out, the product will not function whatsoever. If this happens, follow the directions below:

- 01) Unplug the unit from electric power source.
- 02) Insert a flat-head screwdriver into a slot in the fuse cover. Turn the screwdriver to the left, at the same time gently push a bit (Turn and Push). The fuse will come out.
- 03) Remove the used fuse. If brown or unclear, it is burned out.
- 04) Insert the replacement fuse into the holder where the old fuse was. Reinsert the fuse cover. Be sure to use a fuse of the same type and specification. See the product specification label for details.

## **Troubleshooting**

---

This troubleshooting guide is meant to help solve simple problems.

If a problem occurs, carry out the steps below in sequence until a solution is found. Once the unit operates properly, do not carry out following steps.

### **No Light**

If the light effect does not operate properly, refer servicing to a technician.

Suspect three potential problem areas as: the power supply, the LEDs, the fuse.

- 01) Power supply. Check if the unit is plugged into an appropriate power supply.
- 02) The LEDs. Return the Performer to your Showtec dealer.
- 03) The fuse. Replace the fuse. See page 17 for replacing the fuse.
- 04) If all of the above appears to be O.K., plug the unit in again.
- 05) If you are unable to determine the cause of the problem, do not open the Performer, as this may damage the unit and the warranty will become void.
- 06) Return the device to your Showtec dealer.

### **No Response to DMX**

Suspect the DMX cable or connectors, a controller malfunction, a light effect DMX card malfunction.

- 01) Check the DMX setting. Make sure that DMX addresses are correct.
- 02) Check the DMX cable: Unplug the unit; change the DMX cable; then reconnect to electrical power. Try your DMX control again.
- 03) Determine whether the controller or light effect is at fault. Does the controller operate properly with other DMX products? If not, take the controller in for repair. If so, take the DMX cable and the light effect to a qualified technician.

| <b>Problem</b>   | <b>Probable cause(s)</b>  | <b>Solution</b>  |
|--|---|--|
| One or more fixtures do not function at all  | No power to the fixture   | <ul style="list-style-type: none"> <li>• Check if power is switched on and cables are plugged in</li> </ul>  |
|  | Primary fuse blown  | <ul style="list-style-type: none"> <li>• Replace fuse</li> </ul>   |
| Fixtures reset correctly, but all respond erratically or not at all to the controller  | The controller is not connected.  | <ul style="list-style-type: none"> <li>• Connect controller.</li> </ul>  |
|  | 3-pin XLR Out of the controller does not match XLR Out of the first fixture on the link (i.e. signal is reversed) | <ul style="list-style-type: none"> <li>• Install a phase reversing cable between the controller and the first fixture on the link</li> </ul>   |
| Fixtures reset correctly, but some respond erratically or not at all to the controller | Poor data quality   | <ul style="list-style-type: none"> <li>• Check data quality. If much lower than 100 percent, the problem may be a bad data link connection, poor quality or broken cables, missing termination plug, or a defective fixture disturbing the link</li> </ul> |
|  | Bad data link connection  | <ul style="list-style-type: none"> <li>• Inspect connections and cables. Correct poor connections. Repair or replace damaged cables</li> </ul>   |
|  | Data link not terminated with 120 Ohm termination plug  | <ul style="list-style-type: none"> <li>• Insert termination plug in output jack of the last fixture on the link</li> </ul>   |
|  | Incorrect addressing of the fixtures  | <ul style="list-style-type: none"> <li>• Check address setting</li> </ul>  |
|  | One of the fixtures is defective and disturbs data transmission on the link                                       | <ul style="list-style-type: none"> <li>• Bypass one fixture at a time until normal operation is restored: unplug both connectors and connect them directly together.</li> <li>• Have the defective fixture serviced by a qualified technician</li> </ul>   |
|  | 3-pin XLR Out on the fixtures does not match (pins 2 and 3 reversed)  | <ul style="list-style-type: none"> <li>• Install a phase-reversing cable between the fixtures or swap pin 2 and 3 in the fixture that behaves erratically</li> </ul>   |
| No light or lamp cuts out intermittently   | Fixture is too hot  | <ul style="list-style-type: none"> <li>• Allow the fixture to cool down</li> <li>• Clean the fan</li> <li>• Make sure air vents in control panel and the front lens are not blocked</li> <li>• Turn up the air conditioning</li> </ul>                     |
|  | LEDs damaged  | <ul style="list-style-type: none"> <li>• Disconnect the fixture and return it to your dealer</li> </ul>  |
|  | The power supply settings do not match local AC voltage and frequency   | <ul style="list-style-type: none"> <li>• Disconnect fixture. Check settings and correct if necessary</li> </ul>  |

## Product Specifications

|   |  |
|---|--|
| Model:                                    | Showtec Performer 60 LED                               |
| Input Voltage:                            | 100-240 VAC, 60/50Hz                                   |
| Power consumption:                        | 75W (full output)                                      |
| DMX linking:                              | 30pcs  |
| Fuse:                                     | T1L/250V   |
| Dimensions:                               | 485 x 450 x 300 mm (LxWxH)                             |
| Weight:                                   | 4,8 kg   |
| <b>Operating and Programming:</b>         |  |
| Signal pin OUT:                           | Pin 1 (earth), pin 2 (-), pin 3 (+)                    |
| DMX Mode:                                 | 1, 3 channels  |
| Signal input:                             | 3-pin XLR male   |
| Signal output:                            | 3-pin XLR female                                       |
| <b>Electro-mechanical effects:</b>        |  |
| Light Source:                             | 1 x 60W COB LED  |
| Light Output:                             | 3500 lumen   |
| Beam angle:                               | 8-45°  |
| Dimmer:                                   | 0-100%   |
| Dim Curve:                                | 8 presets  |
| Strobe:                                   | 0-20Hz   |
| Color Temperature:                        | 3200K  |
| Housing:                                  | Die-cast aluminium & flame retardant plastic           |
| DMX-control:                              | via standard DMX-controller                            |
| Onboard:                                  | LCD display for easy setup                             |
| Control:                                  | Auto, Dimmer, Sound-controlled, Master/Slave, DMX-512  |
| Connections:                              | PowerCon IN & OUT to Schuko & dedicated data connector |
| IP Rating:                                | IP20   |
| Cooling:                                  | Forced cooling   |
| Max. ambient temperature $t_a$ :          | 40°C   |
| Max. housing temperature $t_B$ :          | 80°C   |
| <b>Minimum distance:</b>                  |  |
| Minimum distance from flammable surfaces: | 0,5 m  |
| Minimum distance to lighted object:       | 1 m  |

Design and product specifications are subject to change without prior notice.



Website: [www.Showtec.info](http://www.Showtec.info)

Email: [service@highlite.nl](mailto:service@highlite.nl)

## Dimensions

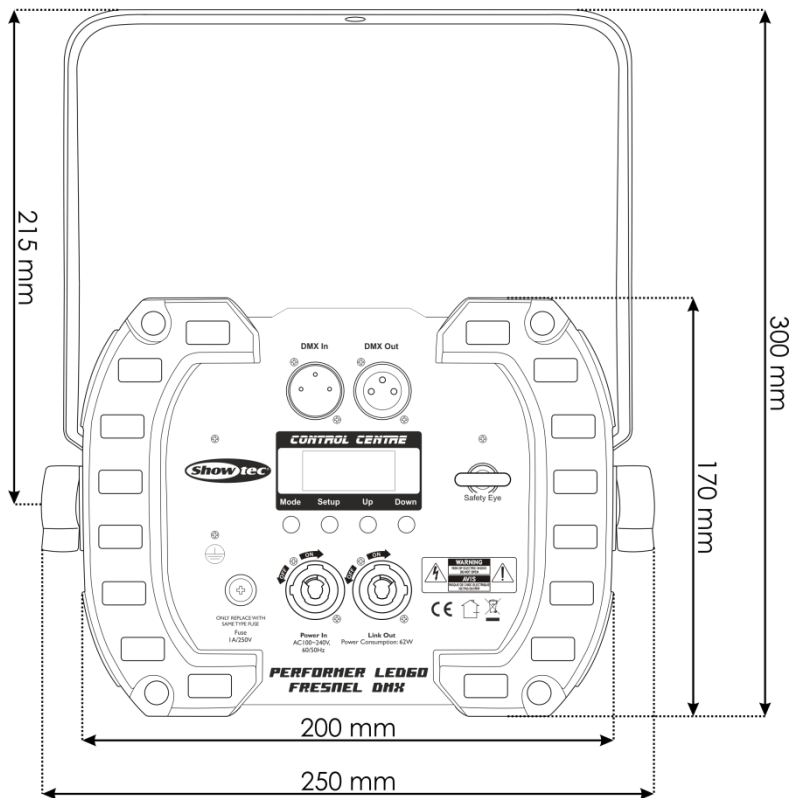
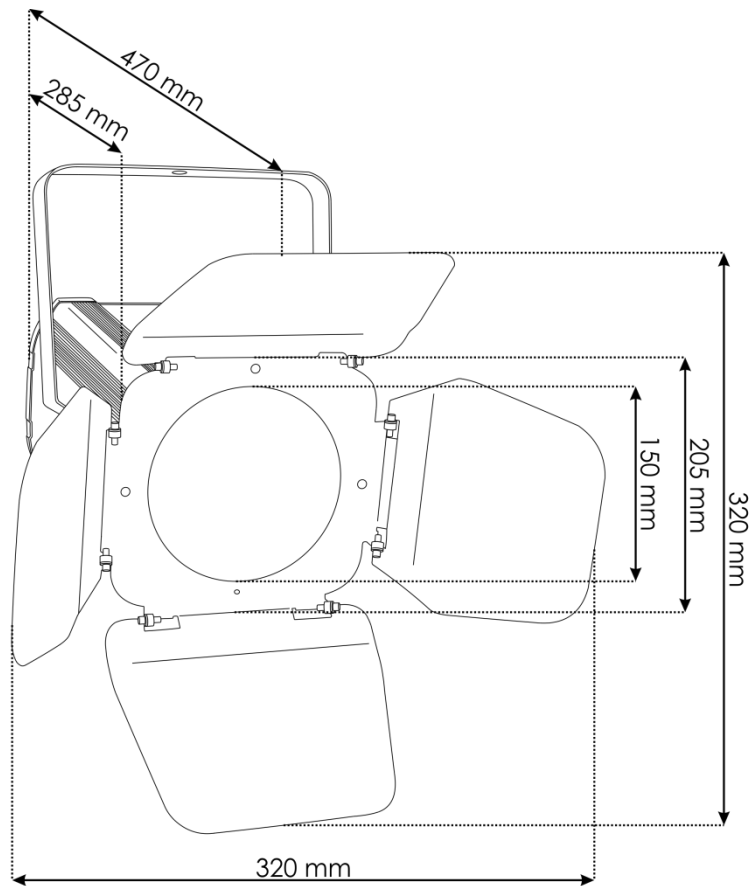





©2015 Showtec