



the
box **pro**

DSP 110 / 112 / 115
active 2-way speaker

Musikhaus Thomann
Thomann GmbH
Hans-Thomann-Straße 1
96138 Burgebrach
Germany
Telephone: +49 (0) 9546 9223-0
E-mail: info@thomann.de
Internet: www.thomann.de

03.07.2018, ID: 401528, 401529, 401530

Table of contents

1	General notes	4
	1.1 Further information.....	5
	1.2 Notational conventions.....	6
	1.3 Symbols and signal words.....	6
2	Safety instructions	8
3	Features	12
4	Starting up	13
5	Connections and controls	15
6	DSP functions	21
7	Technical specifications	23
8	Plug and connection assignment	26
9	Cleaning	29
10	Protecting the environment	30

1 General notes

This manual contains important instructions for the safe operation of the unit. Read and follow the safety instructions and all other instructions. Keep the manual for future reference. Make sure that it is available to all those using the device. If you sell the unit please make sure that the buyer also receives this manual.

Our products are subject to a process of continuous development. Thus, they are subject to change.

1.1 Further information

On our website (www.thomann.de) you will find lots of further information and details on the following points:

Download	This manual is also available as PDF file for you to download.
Keyword search	Use the search function in the electronic version to find the topics of interest for you quickly.
Online guides	Our online guides provide detailed information on technical basics and terms.
Personal consultation	For personal consultation please contact our technical hotline.
Service	If you have any problems with the device the customer service will gladly assist you.

1.2 Notational conventions

This manual uses the following notational conventions:

Letterings

The letterings for connectors and controls are marked by square brackets and italics.

Examples: *[VOLUME]* control, *[Mono]* button.



Displays

Texts and values displayed on the device are marked by quotation marks and italics.

Examples: *'24ch'*, *'OFF'*.

1.3 Symbols and signal words

In this section you will find an overview of the meaning of symbols and signal words that are used in this manual.

Signal word	Meaning
DANGER!	This combination of symbol and signal word indicates an immediate dangerous situation that will result in death or serious injury if it is not avoided.
CAUTION!	This combination of symbol and signal word indicates a possible dangerous situation that can result in minor injury if it is not avoided.
NOTICE!	This combination of symbol and signal word indicates a possible dangerous situation that can result in material and environmental damage if it is not avoided.
Warning signs	Type of danger
	Warning – high-voltage.
	Warning – danger zone.

2 Safety instructions

Intended use

This device is intended to be used in a sound reinforcement system. Use the device only as described in this user manual. Any other use or use under other operating conditions is considered to be improper and may result in personal injury or property damage. No liability will be assumed for damages resulting from improper use.

This device may be used only by persons with sufficient physical, sensorial, and intellectual abilities and having corresponding knowledge and experience. Other persons may use this device only if they are supervised or instructed by a person who is responsible for their safety.



DANGER!

Danger for children

Ensure that plastic bags, packaging, etc. are disposed of properly and are not within reach of babies and young children. Choking hazard!

Ensure that children do not detach any small parts (e.g. knobs or the like) from the unit. They could swallow the pieces and choke!

Never let children unattended use electrical devices.



DANGER!

Electric shock caused by high voltages inside

Within the device there are areas where high voltages may be present. Never remove any covers.

There are no user-serviceable parts inside.

Do not use the device if covers, protectors or optical components are missing or damaged.



DANGER!

Electric shock caused by short-circuit

Always use proper ready-made insulated mains cabling (power cord) with a protective contact plug. Do not modify the mains cable or the plug. Failure to do so could result in electric shock/death or fire. If in doubt, seek advice from a registered electrician.



CAUTION!

Possible hearing damage

The device can produce volume levels that may cause temporary or permanent hearing impairment. Over an extended period of time, even levels that seem to be uncritical can cause hearing damage.

Decrease the volume level immediately if you experience ringing in your ears or hearing impairment. If this is not possible, keep a greater distance or use sufficient ear protectors.



NOTICE!

Risk of fire

Do not block areas of ventilation. Do not install the device near any direct heat source. Keep the device away from naked flames.



NOTICE!

Power supply

Before connecting the device, ensure that the input voltage (AC outlet) matches the voltage rating of the device and that the AC outlet is protected by a residual current circuit breaker. Failure to do so could result in damage to the device and possibly injure the user.

Unplug the device before electrical storms occur and when it is unused for long periods of time to reduce the risk of electric shock or fire.

3 Features

The 2-way active speaker is characterized by the following features:

- 2-way active speaker box for PA and DJ application
- maximum output power 1000 W, 1200 W or 1400 W (depending on the model)
- 10", 12", 15 or 18" woofer (depending on the model)
- 1", 1.35" or 1.45" compression driver (depending on the model)
- backlit display for DSP functions
- 3-band DSP equalizer with ± 12 dB level control per band
- 4 DSP sound programmes: Music, Live, Voice, DJ
- Low-Cut filter, switchable at 80, 100, 120 or 150 Hz
- 2 \times adjustable MIC / Line input, XLR / 1/4" combo socket
- 1 \times Line out, XLR
- solid plastic housing with pole mount and handles
- Standby function (DSP 100 and DSP 112)

4 Starting up

Unpack and carefully check that there is no transportation damage before using the unit. Keep the equipment packaging. To fully protect the device against vibration, dust and moisture during transportation or storage use the original packaging or your own packaging material suitable for transport or storage, respectively.

Create all connections while the device is off. Use the shortest possible high-quality cables for all connections. Take care when running the cables to prevent tripping hazards.



NOTICE!

Possible property damage by magnetic fields

Loudspeakers produce a static magnetic field. Therefore, maintain an appropriate distance to devices that can be adversely affected or damaged by an external magnetic field.

The unit can be mounted on a tripod or set up on the floor or a sufficiently sized and stable surface.



NOTICE!

Use of stands

When mounting the device onto a stand, ensure that the stand is in a safe and stable position and that the weight of the device does not exceed the maximum permissible load capacity of the stand.

5 Connections and controls

Model DSP 110

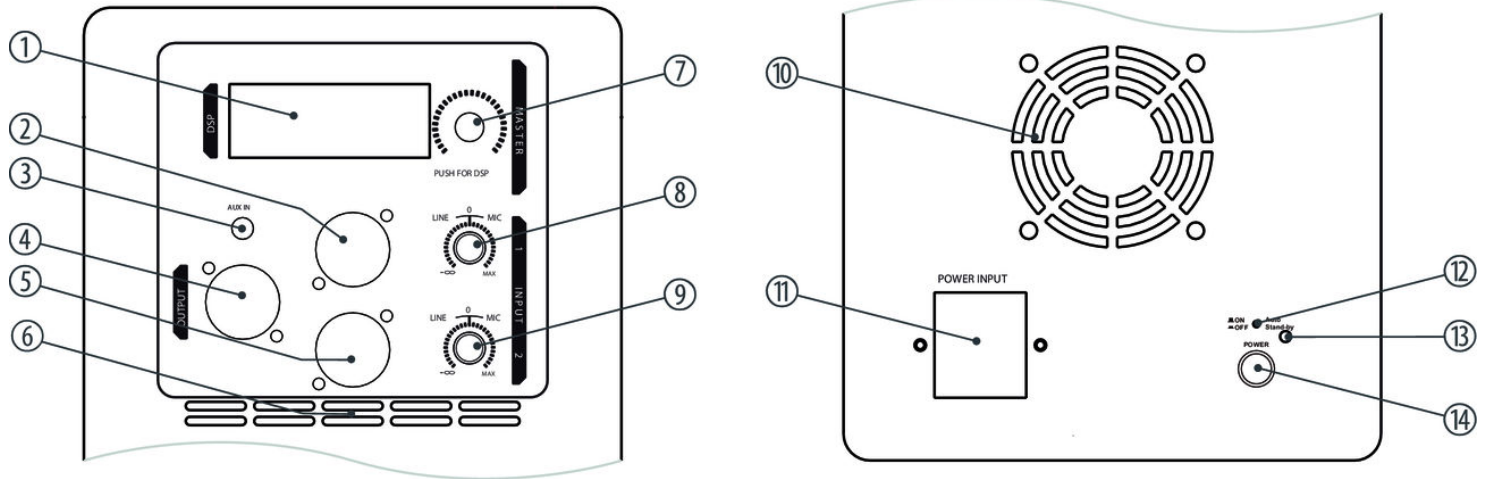

DSP 110 / 112 / 115

Model DSP 112

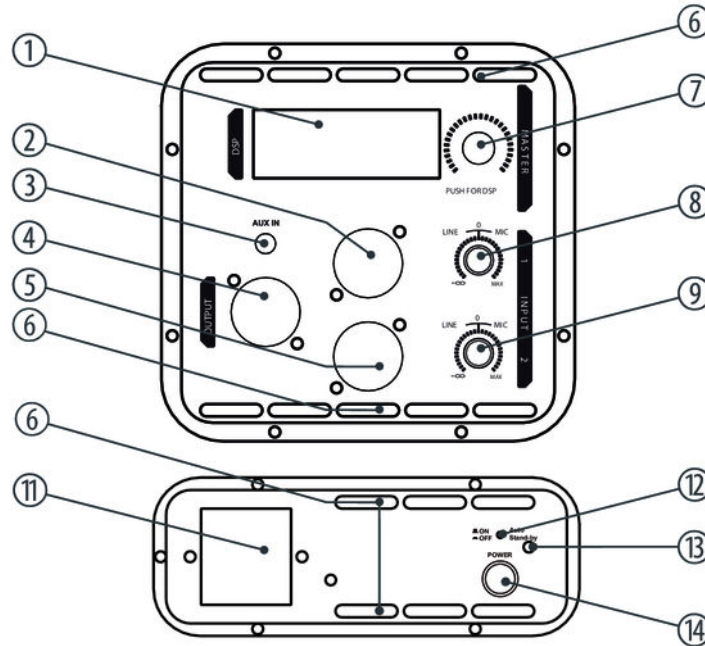

Model DSP 115

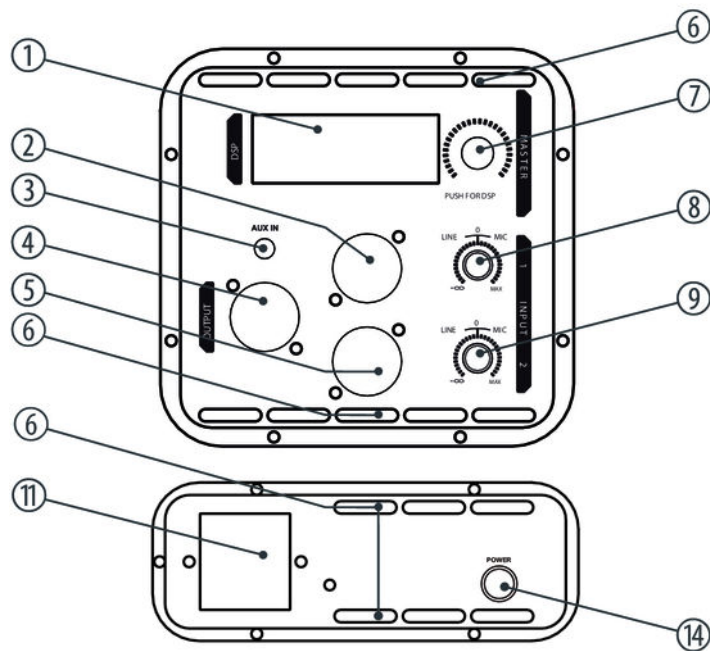

DSP 110 / 112 / 115

1	<i>[DSP]</i> Backlit display for DSP functions.
2	<i>[INPUT 1]</i> Mic / Line input 1, designed as XLR / 1/4" combo socket, balanced.
3	<i>[AUX IN]</i> 3.5 mm phone socket for connecting line level devices such as MP3 or CD players. Stereo signals are combined.
4	<i>[OUTPUT]</i> Line output, designed as XLR chassis plug. The combined signal of both inputs is present here, unaffected by DSP.
5	<i>[INPUT 2]</i> Mic / Line input 1, designed as XLR / 1/4" combo socket, balanced.
6	Vents.
7	<i>[MASTER / PUSH FOR DSP]</i> Rotary control for the overall volume, push button for activating the DSP functions.

8	-∞ MAX INPUT 1 Rotary gain control for input 1. Turning clockwise increases the input gain for connecting microphones. Turning counterclockwise decreases the input gain for connecting instruments or devices with line level outputs.
9	-∞ MAX INPUT 2 Rotary gain control for input 2. Turning clockwise increases the input gain for connecting microphones. Turning counterclockwise decreases the input gain for connecting instruments or devices with line level outputs.
10	Chassis fan grill.
11	<i>[POWER INPUT]</i> IEC chassis plug for power supply with fuse holder. To replace the fuse, carefully take out the fuse holder with a small screwdriver, replace the defective fuse with a new one of the same type and push the fuse holder back in until it snaps into place.
12	Switch <i>[AUTO Stand-by]</i> (DSP 110, DSP 112) Behind this opening, you find the switch that turns the automatic shutdown function on and off. When pressed, the function is deactivated, when not pressed, it is activated. The device will turn off after approx. 60 minutes without input signal. When the input signal recurs, the device returns automatically.

- | | |
|----|---|
| 13 | LED [<i>AUTO Stand-by</i>] (DSP 110, DSP 112)
This LED lights when the automatic shutdown function is turned on. |
| 14 | [<i>POWER ON / OFF</i>]
Power on/off switch. |

6 DSP functions

Sound programmes

Press the button *[MASTER VOL | PUSH FOR DSP]* once during operation to call up the unit's DSP function 'Sound Programme'. 'MUSIC' appears in the display. Press again the button *[MASTER VOL | PUSH FOR DSP]* to enable this function. Or turn the knob to select another sound programme 'LIVE', 'VOICE' or 'DJ' and press the *[MASTER VOL | PUSH FOR DSP]* button.

3-band EQ

Press the button *[MASTER VOL | PUSH FOR DSP]* twice during operation to call up the unit's DSP function '3-Band EQ'. 'HIGH EQ' (treble control) appears in the display. Press again the button *[MASTER VOL | PUSH FOR DSP]* to enable this function. Or turn the knob to select another sound programme 'MID EQ' (mid control) or 'LOW EQ' (bass control) and press the *[MASTER VOL | PUSH FOR DSP]* button. Then turn the knob clockwise to raise the level of the selected frequency band by up to 12 dB. Or turn the knob counterclockwise to lower the level of the selected frequency band by up to 12 dB.

2 level meters

Press the button *[MASTER VOL | PUSH FOR DSP]* three times during operation to call up the unit's DSP function '2 Level Meters'. 'INPUT 1' appears in the display along with a graphical representation of input level 1. Turn the knob until 'INPUT 2' appears in the display along with a graphical representation of input level 2.

Low-Cut filter

Press the button *[MASTER VOL | PUSH FOR DSP]* four times during operation to call up the unit's DSP function 'High Pass Filter'. '80 Hz' (frequency attenuation below 80 Hz) appears in the display. Press again the button *[MASTER VOL | PUSH FOR DSP]* to enable this function. Or turn the knob to select another cut-off frequency '100 Hz', '120 Hz' or '150 Hz' and press the *[MASTER VOL | PUSH FOR DSP]* button.

7 Technical specifications

DSP 110

Inputs	2 × XLR / 1/4" combo socket, balanced; 1 × 3.5 mm phone socket
Output	1 × XLR (line level mix from both inputs)
Speaker	Two-way system with 1.35" compression driver and 10" woofer
Max. sound pressure level	132 dB
Frequency range	58 Hz ... 19 kHz
Output power	1000 W (peak)
Operating supply voltage	AC 230 V ~ 50 Hz
Power consumption	300 W
Fuse	5 mm × 20 mm, 2 A, 250 V, slow-blow
Dimensions (W × H × D)	298 mm × 523 mm × 307 mm
Weight	13 kg

DSP 112

Inputs	2 × XLR / 1/4" combo socket, balanced; 1 × 3.5 mm phone socket
Output	1 × XLR (line level mix from both inputs)
Speaker	Two-way system with 1.35" compression driver and 12" woofer
Max. sound pressure level	134 dB
Frequency range	53 Hz ... 19 kHz
Output power	1200 W (peak)
Operating supply voltage	AC 230 V ~ 50 Hz
Power consumption	400 W
Fuse	5 mm × 20 mm, 3.15 A, 250 V, slow-blow
Dimensions (W × H × D)	348 mm × 607 mm × 355 mm
Weight	14.6 kg

DSP 115

Inputs	2 × XLR / 1/4" combo socket, balanced; 1 × 3.5 mm phone socket
Output	1 × XLR (line level mix from both inputs)
Speaker	Two-way system with 1.45" compression driver and 15" woofer
Max. sound pressure level	136 dB
Frequency range	48 Hz ... 19 kHz
Output power	1400 W (peak)
Operating supply voltage	AC 230 V ~ 50 Hz
Power consumption	500 W
Fuse	5 mm × 20 mm, 3.15 A, 250 V, slow-blow
Dimensions (W × H × D)	420 mm × 695 mm × 395 mm
Weight	20 kg

8 Plug and connection assignment

Introduction

This chapter will help you select the right cables and plugs to connect your valuable equipment in such a way that a perfect sound experience is ensured.

Please note these advices, because especially in 'Sound & Light' caution is indicated: Even if a plug fits into the socket, an incorrect connection may result in a destroyed power amp, a short circuit or 'just' in poor transmission quality!

Balanced and unbalanced transmission

Unbalanced transmission is mainly used in semi-professional environment and in hifi use. Instrument cables with two conductors (one core plus shielding) are typical representatives of the unbalanced transmission. One conductor is ground and shielding while the signal is transmitted through the core.

Unbalanced transmission is susceptible to electromagnetic interference, especially at low levels, such as microphone signals and when using long cables.

In a professional environment, therefore, the balanced transmission is preferred, because this enables an undisturbed transmission of signals over long distances. In addition to the conductors 'Ground' and 'Signal', in a balanced transmission a second core is added. This also transfers the signal, but phase-shifted by 180°.

Since the interference affects both cores equally, by subtracting the phase-shifted signals, the interfering signal is completely neutralized. The result is a pure signal without any noise interference.

1/4" TS phone plug (mono, unbalanced)



1	Signal
2	Ground, shielding

1/4" TRS phone plug (mono, balanced)



1	Signal (in phase, +)
2	Signal (out of phase, -)
3	Ground

XLR plug (balanced)

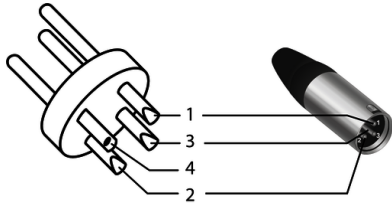

1	Ground, shielding
2	Signal (in phase, +)
3	Signal (out of phase, -)
4	Shielding on plug housing (option)

XLR plug (unbalanced)

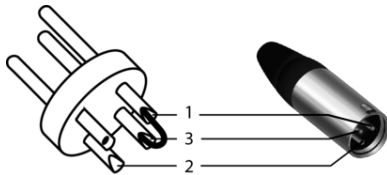

1	Ground, shielding
2	Signal
3	Bridged to pin 1

9 Cleaning

Device components

Clean the device components that are accessible from the outside regularly. The cleaning frequency depends on the operating environment: damp, smoky or particularly dirty environments can cause greater accumulation of dirt on the device components.

- Clean with a dry soft cloth.
- Stubborn dirt can be removed with a slightly dampened cloth.
- Never use solvents or alcohol for cleaning.

10 Protecting the environment

Disposal of the packaging material



For the transport and protective packaging, environmentally friendly materials have been chosen that can be supplied to normal recycling.

Ensure that plastic bags, packaging, etc. are properly disposed of.

Do not just dispose of these materials with your normal household waste, but make sure that they are collected for recycling. Please follow the notes and markings on the packaging.

Disposal of your old device



This product is subject to the European Waste Electrical and Electronic Equipment Directive (WEEE) in its currently valid version. Do not dispose with your normal household waste.

Dispose of this device through an approved waste disposal firm or through your local waste facility. When discarding the device, comply with the rules and regulations that apply in your country. If in doubt, consult your local waste disposal facility.



Musikhaus Thomann · Hans-Thomann-Straße 1 · 96138 Burgebrach · Germany · www.thomann.de