

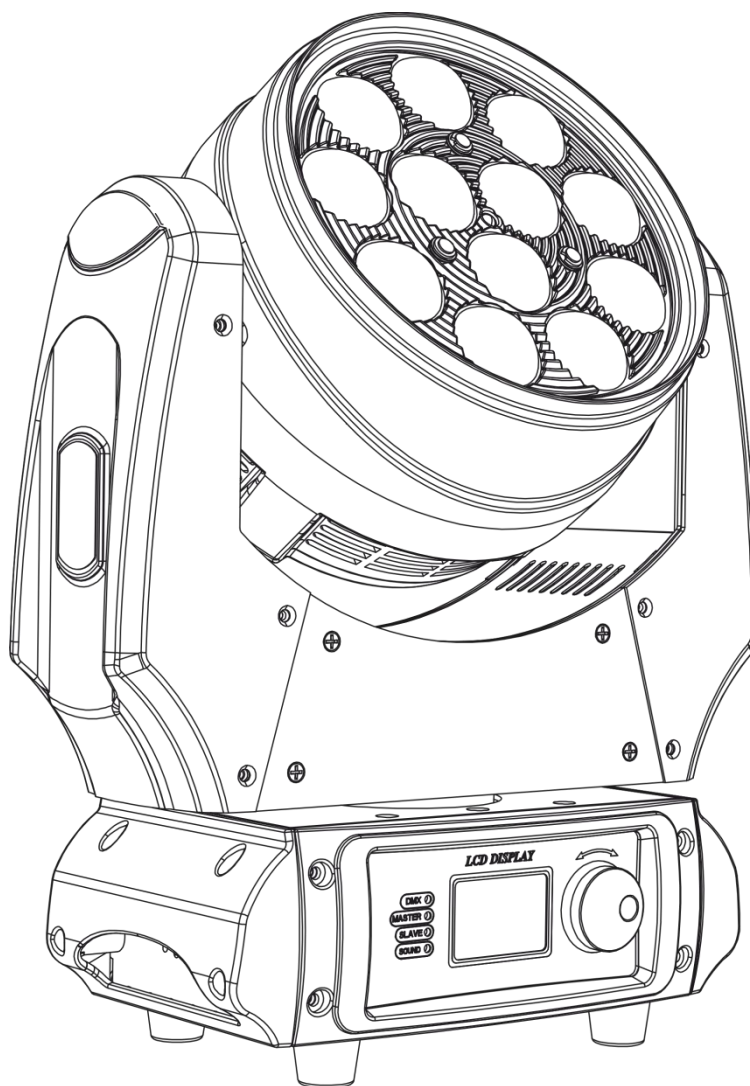

MANUAL



ENGLISH

Phantom 120 LED Wash V1

Ordercode: 40030

Table of contents

Warning 3

 Safety Instructions 3

 Operating Determinations 5

 Rigging 5

 Connection with the mains 6

 Return Procedure 6

 Claims 6

Description of the device 7

 Overview 7

 Frontside 8

 Backside 9

Installation 9

Set Up and Operation 9

 Control Modes 10

 One Phantom 120 Wash RGBW (Built-in Programs and Manual) 10

 One Phantom 120 Wash RGBW (Sound-controlled) 10

 Multiple Phantom Washes (Master/Slave Control) 10

 Multiple Phantom Washes (DMX Control) 11

 Fixture Linking 12

 Data Cabling 12

 Control Panel 13

 DMX Control Mode 13

 DMX Addressing 13

 Menu Overview 14

 Main Menu Options 15

 1. DMX Address 15

 2. Channel Mode 16

 3. Run Mode 16

 3.1 DMX Mode 16

 3.2 Master Mode 16

 3.3 Slave Mode 17

 3.4 Sound Mode 17

 3.5 Manual Mode 17

 4. Functions Mode 18

 4.1 Pan Invert 18

 4.2 Tilt Invert 18

 4.3 Dimmer Curve 19

 4.4 DMX Fail Curve 19

 4.5 Display 19

 4.6 Back Light 20

 4.7 Reset 20

 4.8 Factory Sets 20

 4.9 Auto Test 20

 5. Version 20

 DMX Channels 21

 16 Channels 23

 Black out during pan/ tilt movement 24

 26 Channels 25

 Black out during pan/ tilt movement 27

Maintenance 29

 Replacing the Fuse 29

Troubleshooting29
 No Light29
 No Response to DMX.....30
Product Specifications31
Dimensions.....32
Notes33

Warning



**For your own safety, please read this user manual carefully
before your initial start-up!**



Unpacking Instructions

Immediately upon receiving this product, carefully unpack the carton and check the contents to ensure that all parts are present, and have been received in good condition. Notify the dealer immediately and retain packing material for inspection if any parts appear damaged from shipping or the carton itself shows signs of mishandling. Save the carton and all packing materials. In the event that a fixture must be returned to the factory, it is important that the fixture be returned in the original factory box and packing.

Your shipment includes:

- Showtec Phantom 120 Wash RGBW
- Mounting bracket with 2 quick-locks
- Pro Power connector to Schuko cable (length 1,5 m)
- User manual

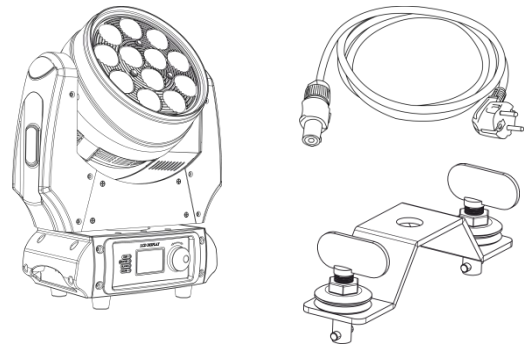

LED Expected Lifespan

LEDs gradually decline in brightness over time. HEAT is the dominant factor that leads to the acceleration of this decline. Packaged in clusters, LEDs exhibit higher operating temperatures than in ideal or singular optimum conditions. For this reason when all color LEDs are used at their fullest intensity, life of the LEDs is significantly reduced. If improving the lifespan is of higher priority, place care in providing for lower operational temperatures. This may include climatic-environmental and the reduction of overall projection intensity.



CAUTION!

**Keep this device away from rain and moisture!
Unplug mains lead before opening the housing!**



Safety Instructions

Every person involved with the installation, operation and maintenance of this device has to:

- be qualified
- follow the instructions of this manual



**CAUTION! Be careful with your operations.
With a dangerous voltage you can suffer
a dangerous electric shock when touching the wires!**



Before your initial start-up, please make sure that there is no damage caused by transportation. Should there be any, consult your dealer and do not use the device.

To maintain perfect condition and to ensure a safe operation, it is absolutely necessary for the user to follow the safety instructions and warning notes written in this manual.

Please consider that damages caused by manual modifications to the device are not subject to warranty.

This device contains no user-serviceable parts. Refer servicing to qualified technicians only.

IMPORTANT:

The manufacturer will not accept liability for any resulting damages caused by the non-observance of this manual or any unauthorized modification to the device.

- Never let the power cord come into contact with other cables! Handle the power cord and all connections with the mains with particular caution!
- Never remove warning or informative labels from the unit.
- Never use anything to cover the ground contact.
- Never lift the fixture by holding it at the projector-head, as the mechanics may be damaged.
- Never place any material over the lens.
- Never look directly into the light source.
- Never leave any cables lying around.
- Do not insert objects into air vents.
- Do not connect this device to a dimmerpack.
- Do not switch the device on and off in short intervals, as this would reduce the device's life.
- Do not touch the device's housing bare-handed during its operation. Allow the fixture to cool for at least 5 minutes before handling.
- Do not shake the device. Avoid brute force when installing or operating the device.
- Only use device indoor, avoid contact with water or other liquids.
- Only operate the fixture after having checked that the housing is firmly closed and all screws are tightly fastened.
- Only operate the device after having familiarized with its functions.
- Avoid flames and do not put close to flammable liquids or gases.
- Always keep case closed while operating.
- Always allow free air space of at least 50 cm around the unit for ventilation.
- Always disconnect power from the mains, when device is not used or before cleaning! Only handle the power cord by the plug. Never pull out the plug by tugging the power cord.
- Make sure that the device is not exposed to extreme heat, moisture or dust.
- Make sure that the available voltage is not higher than stated on the rear panel.
- Make sure that the power cord is never crimped or damaged. Check the device and the power cord from time to time.
- If the lens is obviously damaged, it has to be replaced. So that its functions are not impaired, due to cracks or deep scratches.
- If device is dropped or struck, disconnect mains power supply immediately. Have a qualified engineer inspect for safety before operating.
- If the device has been exposed to drastic temperature fluctuation (e.g. after transportation), do not switch it on immediately. The arising condensation water might damage your device. Leave the device switched off until it has reached room temperature.
- If your Showtec device fails to work properly, discontinue use immediately. Pack the unit securely (preferably in the original packing material), and return it to your Showtec dealer for service.
- For adult use only. Device must be installed out of the reach of children. Never leave the unit running unattended.
- Never attempt to bypass the thermostatic switch or fuses.
- For replacement use fuses of same type and rating only.
- The user is responsible for correct positioning and operating of the Phantom 120 Wash RGBW. The manufacturer will not accept liability for damages caused by the misuse or incorrect installation of this device.
- This device falls under protection class I. Therefore it is essential to connect the yellow/green conductor to earth.
- During the initial start-up some smoke or smell may arise. This is a normal process and does not necessarily mean that the device is defective.
- Repairs, servicing and electric connection must be carried out by a qualified technician.
- WARRANTY: Till one year after date of purchase.



CAUTION! Eyedamages!!!
Avoid looking directly into the lightsource!!!
(meant especially for epileptics)!!!



Operating Determinations

- This device is not designed for permanent operation. Consistent operation breaks will ensure that the device will serve you for a long time without defects.
- The minimum distance between light-output and the illuminated surface must be more than 1 meter.
- The maximum ambient temperature $t_a = 40^\circ\text{C}$ must never be exceeded.
- The relative humidity must not exceed 50 % with an ambient temperature of 40°C .
- If this device is operated in any other way, than the one described in this manual, the product may suffer damages and the warranty becomes void.
- Any other operation may lead to dangers like short-circuit, burns, electric shock, crash etc.

You endanger your own safety and the safety of others!

Rigging

Please follow the European and national guidelines concerning rigging, trussing and all other safety issues.

Do not attempt the installation yourself !

Always let the installation be carried out by an authorized dealer !

Procedure:

- If the Phantom 120 Wash RGBW is lowered from the ceiling or high joists, professional trussing systems have to be used.
- Use a clamp to mount the Phantom 120 Wash RGBW, with the mounting-bracket, to the trussing system.
- The Phantom 120 Wash RGBW must never be fixed swinging freely in the room.
- The installation must always be secured with a safety attachment, e.g. an appropriate safety net or safety-cable.
- When rigging, derigging or servicing the projector, always make sure, that the area below the installation place is blocked and staying in the area is forbidden.

Mounting a bracket and quick-locks to the underside of the Phantom 120 Wash RGBW.

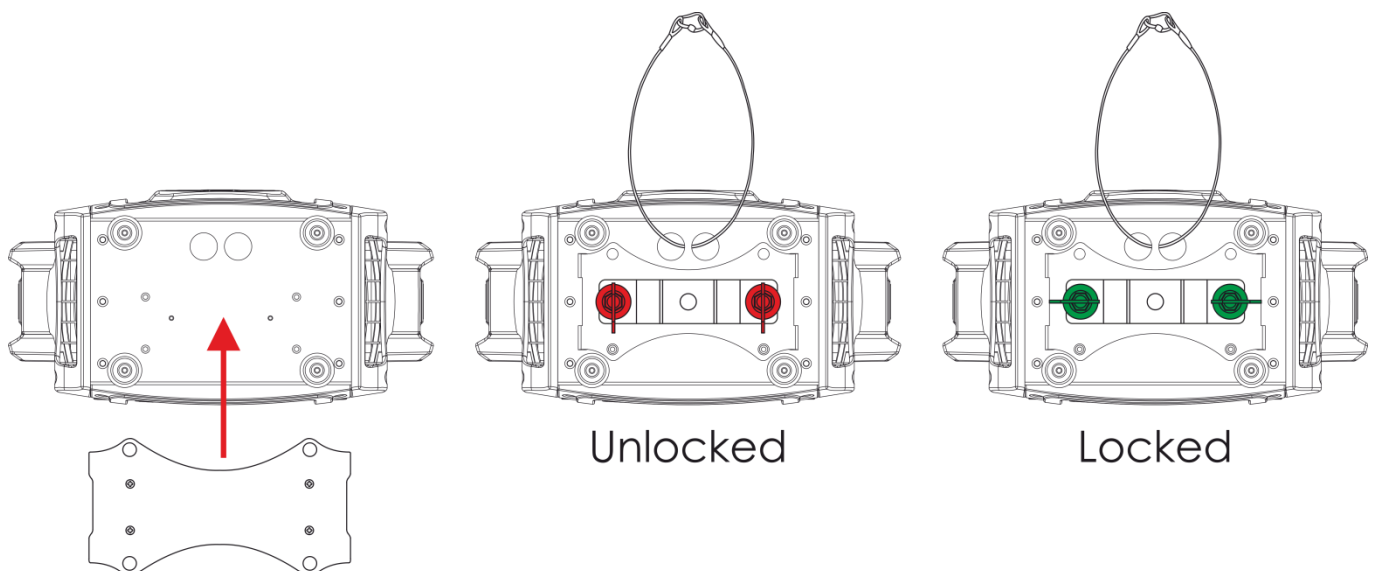

The Phantom 120 Wash RGBW can be placed on a flat stage floor or be mounted to any kind of truss by means of a mounting bracket with quick-locks.

Improper installation can cause serious damage to people and property!

Connection with the mains

Connect the device to the mains with the power-plug.

Always pay attention, that the right color cable is connected to the right place.

International	EU Cable	UK Cable	US Cable	Pin
L	BROWN	RED	YELLOW/COPPER	PHASE
N	BLUE	BLACK	SILVER	NEUTRAL
	YELLOW/GREEN	GREEN	GREEN	PROTECTIVE GROUND

Make sure that the device is always connected properly to the earth!

Improper installation can cause serious damage to people and property!

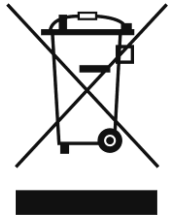

Return Procedure



Returned merchandise must be sent prepaid and in the original packing, call tags will not be issued. Package must be clearly labeled with a Return Authorization Number (RMA number). Products returned without an RMA number will be refused. Highlite will not accept the returned goods or any responsibility. Call Highlite 0031-455667723 or mail offersales@highlite.nl and request an RMA prior to shipping the fixture. Be prepared to provide the model number, serial number and a brief description of the cause for the return. Be sure to properly pack fixture, any shipping damage resulting from inadequate packaging is the customer's responsibility. Highlite reserves the right to use its own discretion to repair or replace product(s). As a suggestion, proper UPS packing or double-boxing is always a safe method to use.

Note: If you are given an RMA number, please include the following information on a piece of paper inside the box:

- 01) Your name.
- 02) Your address.
- 03) Your phone number.
- 04) A brief description of the symptoms.

Claims

The client has the obligation to check the delivered goods immediately upon delivery for any shortcomings and/or visible defects, or perform this check after our announcement that the goods are at their disposal. Damage incurred in shipping is the responsibility of the shipper; therefore the damage must be reported to the carrier upon receipt of merchandise.

It is the customer's responsibility to notify and submit claims with the shipper in the event that a fixture is damaged due to shipping. Transportation damage has to be reported to us within one day after receipt of the delivery.

Any return shipment has to be made post-paid at all times. Return shipments must be accompanied with a letter defining the reason for return shipment. Non-prepaid return shipments will be refused, unless otherwise agreed in writing.

Complaints against us must be made known in writing or by fax within 10 working days after receipt of the invoice. After this period complaints will not be handled anymore.

Complaints will only then be considered if the client has so far complied with all parts of the agreement, regardless of the agreement of which the obligation is resulting.

Description of the device

Features

The Showtec Phantom 120 Wash RGBW is a moving-head with high output and great effects.

- Combine or alternating the wash effect with the backlight colors to create more dramatic effects.
- Both wash and backlight LEDs are independently controllable in color-mix, dimmer, strobe and have their own preset colors to get total control.
- Onboard: Bright LCD display for easy setup
- Input voltage: 100-240 VAC, 60/50Hz
- Power consumption: 135W max. at full output
- LED Quantity: 12 x 10W RGBW 4-in-1 LEDs
- Continuous Pan & Tilt
- Control mode: Auto, Manual, Sound-controlled, Master/Slave, DMX512
- Preset colors, built-in color jump and fade programs are selectable by DMX
- Special: Pan/ Tilt reverse & Black out by DMX
- DMX Modes: 10, 16, 26 Channels
- DMX-control via standard DMX-controller
- Beam angle: 5° - 60°
- Dimmer: 0-100% electronic dimmer
- Compact Powerful Beam
- Motorized Zoom
- IFS Technology
- Strobe: 0-20Hz
- Dimmer curves: Linear, Square, I-Square, S curve
- Clear Lens with RGB backlight
- Backlight System: 21 x RGB 5050 SMD
- RGBW Color mixing
- Pan 0° -- 540°, Tilt 0° -- 270°
- Pan/Tilt resolution: 16 bit
- On-Board: Display including gravity sensor
- Lux @ 2m: 14300lux (5°)
- Power Connections: Blue Pro Power connector IN and Grey Pro Power connector OUT
- Data Connections: 3-pin DMX IN and OUT
- Fuse: T3A/250V
- Working temperature: -10°C~40°C
- Housing: Black Flame-retardant plastic, Die-cast aluminum
- Dimensions: 309 x 152 x 385 mm (LxWxH)
- Weight: 6,9 kg
- Included: Pro Power connector to Schuko cable (length 1,5 m) and mounting bracket

Overview

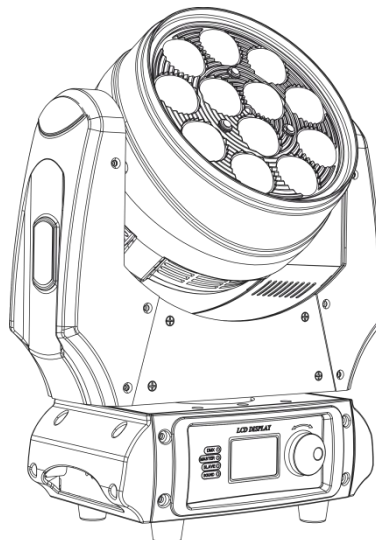
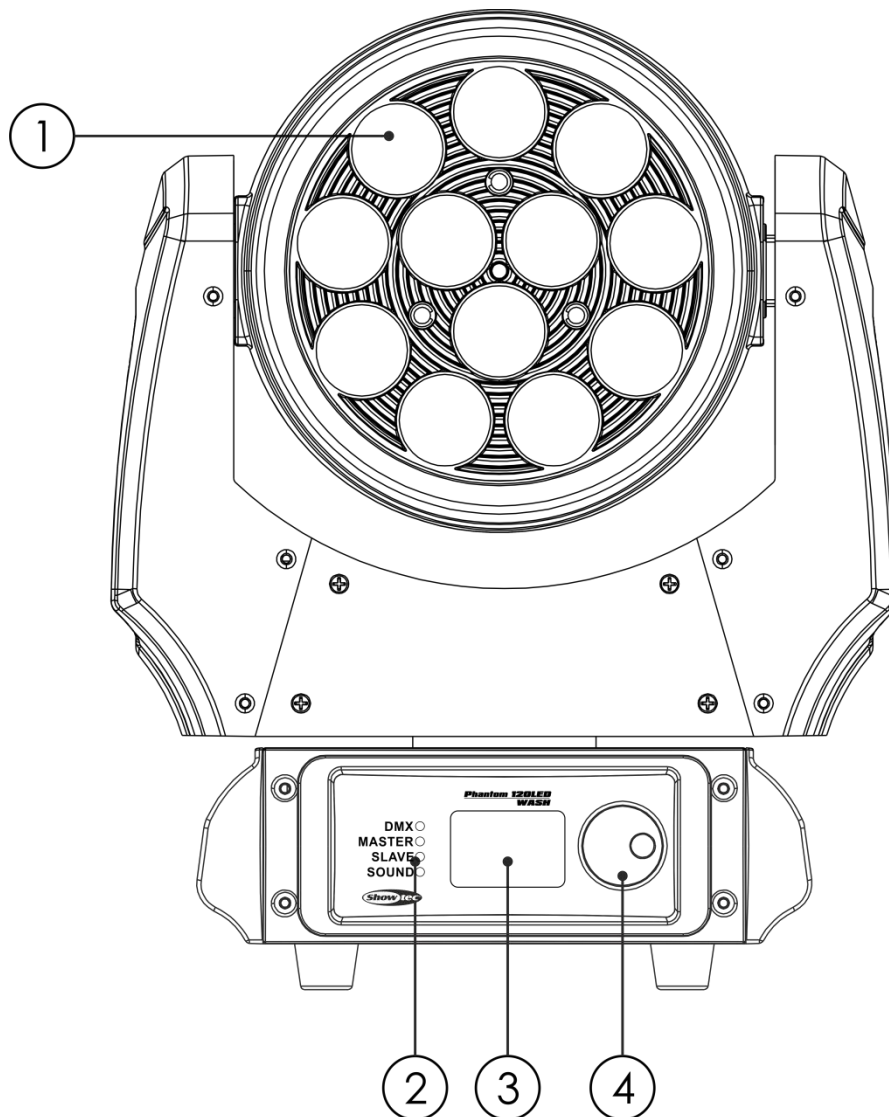

Fig. 01

Frontside



- 01) 12 x 10W RGBW 4-in-1 LEDs
- 02) Control LEDs
- 03) LCD Display
- 04) MENU control

NOTE: Knowledge of DMX is required to fully utilize this unit.

Fig. 02

Backside

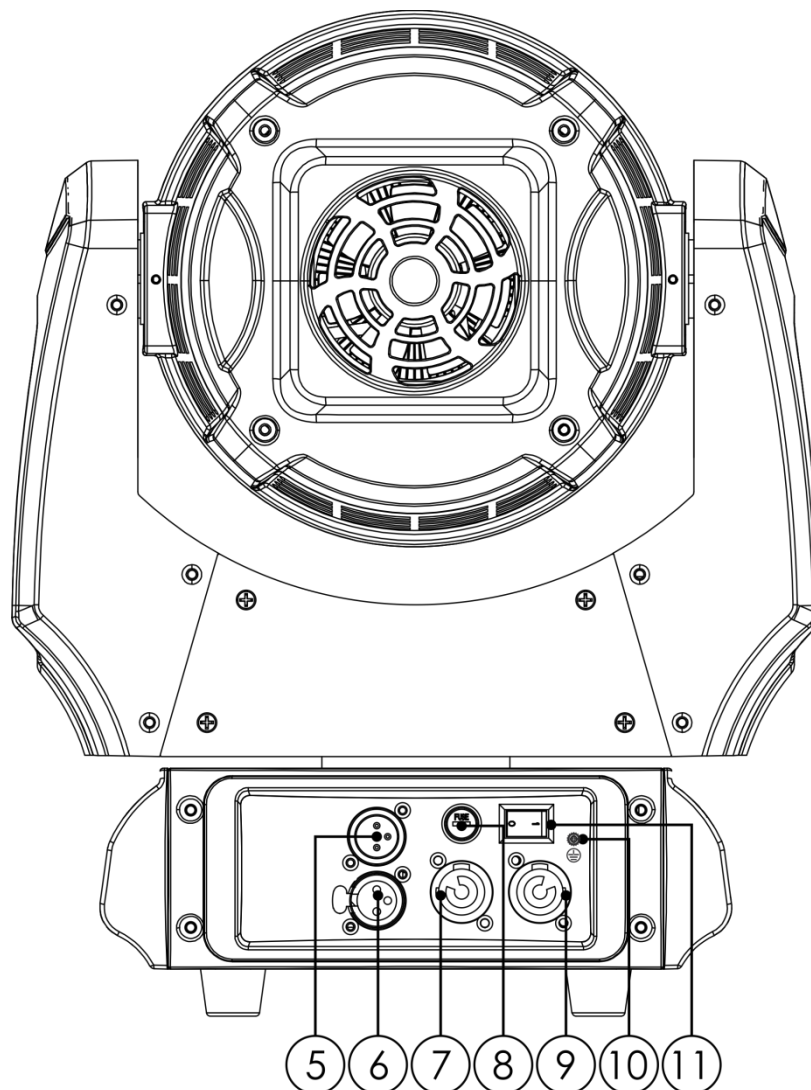

Fig. 03

- 05) 3-pin DMX signal connector IN
- 06) 3-pin DMX signal connector OUT
- 07) Blue Pro Power connector IN
- 08) Fuse T3A/250V
- 09) Grey Pro Power connector OUT
- 10) Ground/earth connection
- 11) Power switch ON/OFF

Installation

Remove all packing materials from the Phantom 120 Wash RGBW. Check if all foam and plastic padding is removed. Connect all cables.

Do not supply power before the whole system is set up and connected properly.

Always disconnect from electric mains power supply before cleaning or servicing.

Damages caused by non-observance are not subject to warranty.

Set Up and Operation

Follow the directions below, as they pertain to your preferred operation mode.

Before plugging the unit in, always make sure that the power supply matches the product specification voltage. Do not attempt to operate a 120V specification product on 230V power, or vice versa.

Control Modes

There are 5 modes:

- Built-in programs (Master Mode)
- Manual
- Sound-controlled
- Master/Slave Mode
- DMX-512 (10CH, 16CH, 26CH)

One Phantom 120 Wash RGBW (Built-in Programs and Manual)

- 01) Fasten the effect light onto firm trussing. Leave at least 0,5 meter on all sides for air circulation.
- 02) Always use a safety cable (ordercode 70140 / 70141).
- 03) Plug the end of the electric mains power cord into a proper electric power supply socket.
- 04) When the Phantom 120 Wash RGBW is not connected with a DMX-cable, it functions as a stand-alone device. Please see page 16 and 17 for more information.

One Phantom 120 Wash RGBW (Sound-controlled)

- 01) Fasten the effect light to a firm trussing. Leave at least 0,5 meter on all sides for air circulation.
- 02) Plug the end of the electric mains power cord into a proper electric power supply socket.
- 03) Turn on the music. If the device is set to sound-control, then the Phantom 120 Wash will react to the beat of the music. Please see page 17 for more information about the sound-control options.

Multiple Phantom Washes (Master/Slave Control)

- 01) Fasten the effect light onto firm trussing. Leave at least 0,5 meter on all sides for air circulation.
- 02) Always use a safety cable (ordercode 70140 / 70141).
- 03) Plug the end of the electric mains power cord into a proper electric power supply socket.
- 04) Use a 3-pin XLR cable to connect the Phantom Washes.

The pins:



- 01) Earth
- 02) Signal (-)
- 03) Signal (+)

- 05) Link the units as shown in (Fig.04). Connect a DMX signal cable from the first unit's DMX "out" socket to the second unit's "in" socket. Repeat this process to link the second, third, and fourth units. You can use the same functions on the master device as described on pages 16-17. This means that you can set your desired operation mode on the master device and all slave devices will react the same as the master device.

Multiple Phantom Washes (Master/Slave Set Up)

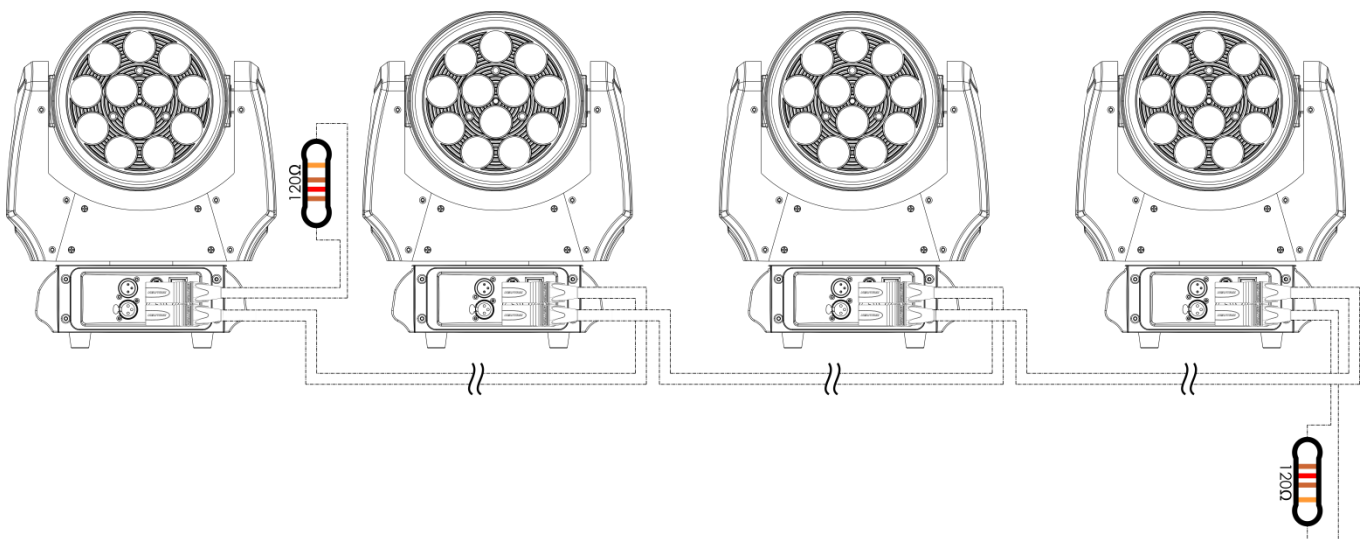
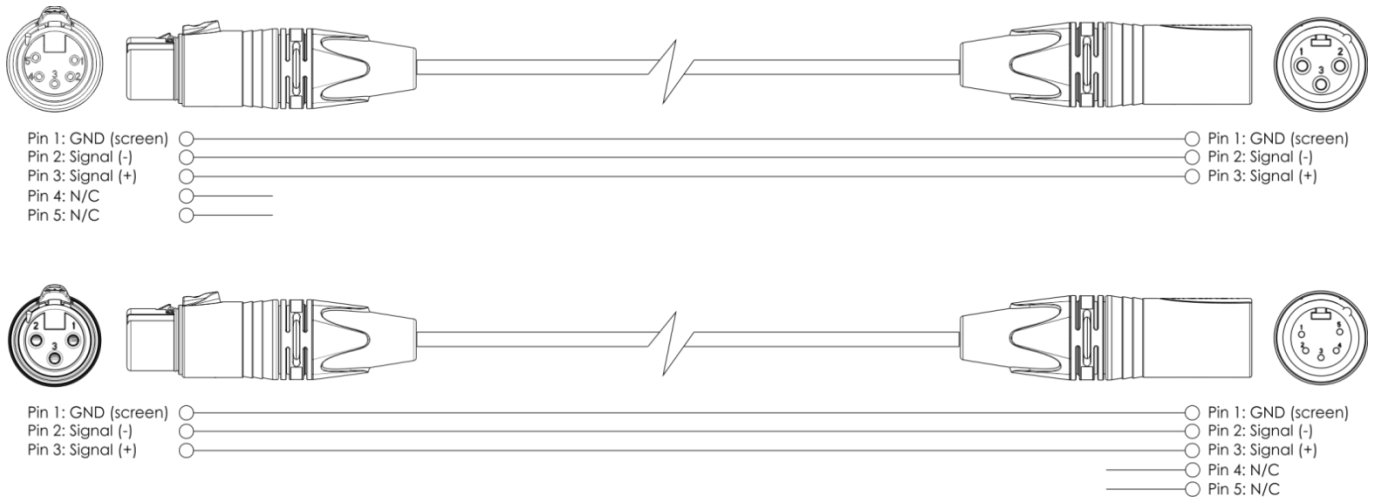

Fig. 04

Multiple Phantom Washes (DMX Control)

- 01) Fasten the effect light onto firm trussing. Leave at least 0,5 meter on all sides for air circulation.
- 02) Always use a safety cable (ordercode 70140 / 70141).
- 03) Plug the end of the electric mains power cord into a proper electric power supply socket.
- 04) Use a 3-pin XLR cable to connect the Phantom Wash RGBW and other devices.



- 05) Link the units as shown in (Fig.05), Connect a DMX signal cable from the first unit's DMX "out" socket to the second unit's "in" socket. Repeat this process to link the second, third, and fourth units.
- 06) Supply electric power: Plug electric mains power cords into each unit's Pro Power socket, then plug the other end of the mains power cord into proper electric power supply sockets, starting with the first unit. Do not supply power before the whole system is set up and connected properly.

Multiple Phantom Washes (DMX Set Up)

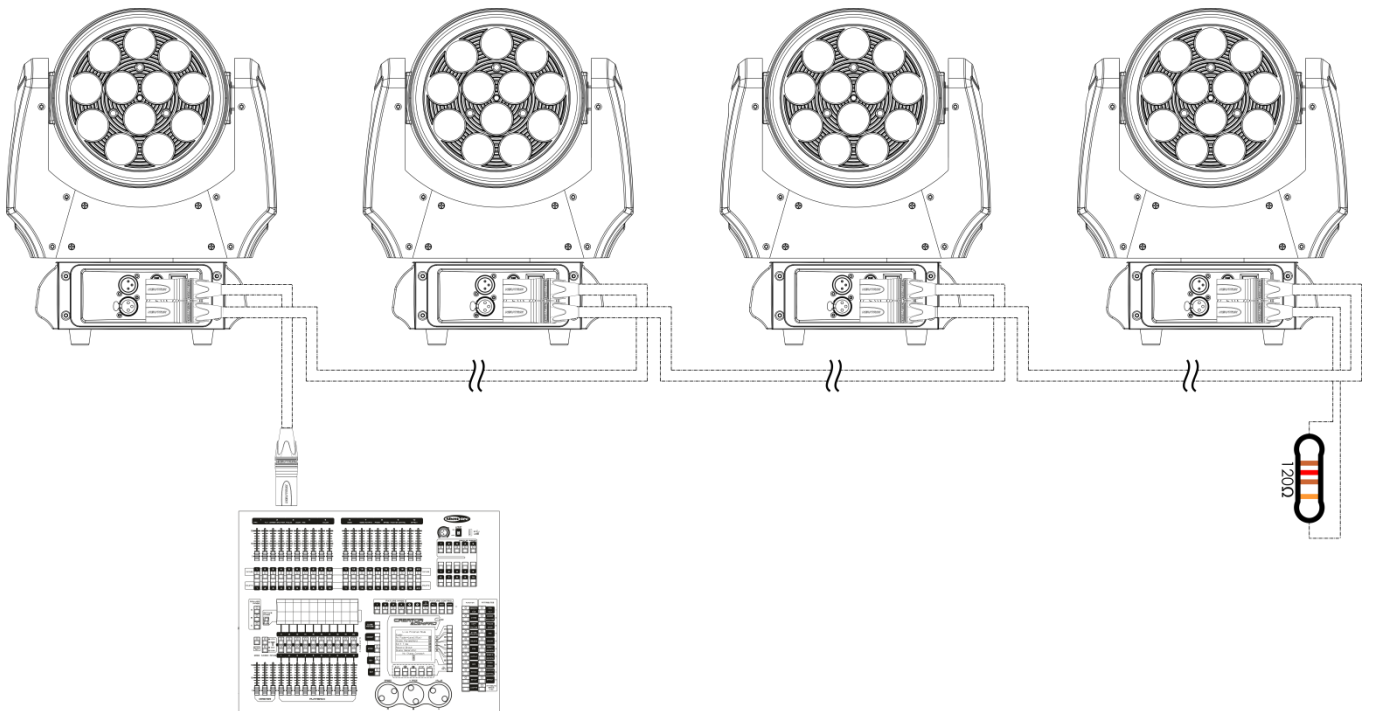

Fig. 05

Fixture Linking

You will need a serial data link to run light shows of one or more fixtures using a DMX-512 controller or to run synchronized shows on two or more fixtures set to a master/slave operating mode. The combined number of channels required by all the fixtures on a serial data link determines the number of fixtures the data link can support.

Important: Fixtures on a serial data link must be daisy chained in one single line. To comply with the EIA-485 standard no more than 30 devices should be connected on one data link. Connecting more than 30 fixtures on one serial data link without the use of a DMX optically isolated splitter may result in deterioration of the digital DMX signal.



Maximum recommended DMX data link distance: 100 meters

Maximum recommended number of Phantom Washes on a DMX data link: 30 fixtures

Data Cabling

To link fixtures together you must obtain data cables. You can purchase DAP Audio certified DMX cables directly from a dealer/distributor or construct your own cable. If you choose to create your own cable please use data-grade cables that can carry a high quality signal and are less prone to electromagnetic interference.

DAP Audio DMX Data Cables

- DAP Audio Basic microphone cable for allround use. bal. XLR/M 3-pin > XLR/F 3-pin. **Ordercode** FL01150 (1,5 m), FL013 (3 m), FL016 (6 m), FL0110 (10 m), FL0115 (15 m), FL0120 (20 m).
- DAP Audio X-type data cable XLR/M 3-pin > XLR/F 3-pin. **Ordercode** FLX0175 (0,75 m), FLX01150 (1,5 m), FLX013 (3 m), FLX016 (6 m), FLX0110 (10 m).
- DAP Audio cable for the demanding user with exceptional audio-qualities and connector made by Neutrik®. **Ordercode** FL71150 (1,5 m), FL713 (3 m), FL716 (6 m), FL7110 (10 m).
- DAP Audio cable for the demanding user with exceptional audio-qualities and connector made by Neutrik®. **Ordercode** FL7275 (0,75 m), FL72150 (1,5 m), FL723 (3 m), FL726 (6 m), FL7210 (10 m).
- DAP Audio 110 Ohm cable with digital signal transmission. **Ordercode** FL0975 (0,75 m), FL09150 (1,5 m), FL093 (3 m), FL096 (6 m), FL0910 (10 m), FL0915 (15 m), FL0920 (20 m).

The Phantom 120 Wash RGBW can be operated with a controller in **control mode** or without the controller in **stand-alone mode**.

Control Panel

- 1 : DMX Address
- 2 : Channel Mode
- 3 : Run Mode
- 4 : Functions

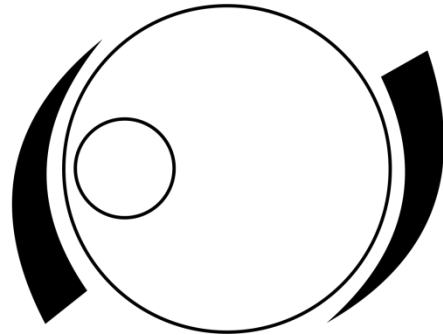

Press and turn the control to navigate through the menu options

Fig. 06

DMX Control Mode

The fixtures are individually addressed on a data-link and connected to the controller. When a DMX signal is present, the DMX LED will blink. The fixtures respond to the DMX signal from the controller. (When you select the DMX address and save it, the controller will display the saved DMX address the next time.)

DMX Addressing

The control panel on the front side of the base allows you to assign the DMX fixture address, which is the first channel from which the Phantom 120 Wash RGBW will respond to the controller.

Please note when you use the controller, the unit has **26** channels.

When using multiple Phantom Washes make sure you set the DMX addresses right.

Therefore, the DMX address of the first Phantom Wash RGBW should be **1(001)**; the DMX address of the second Phantom Wash RGBW should be **1+26=27 (027)**; the DMX address of the third Phantom Wash RGBW should be **27+26=53 (053)**, etc.

Please, be sure that you do not have any overlapping channels in order to control each Phantom Wash RGBW correctly.

If two or more Phantom Washes are addressed similarly, they will work similarly.

Controlling:

After having addressed all Phantom Wash RGBW fixtures, you may now start operating these via your lighting controller.

Note: After switching on, the Phantom Wash RGBW will automatically detect whether DMX 512 data is received or not. If there is no data received at the DMX-input, the DMX LED will not blink.

The problem may be:

- The XLR cable from the controller is not connected with the input of the Phantom Wash RGBW.
- The controller is switched off or defective, the cable or connector is defective, or the signal wires are swapped in the input connector.

Note: It is necessary to insert an XLR termination plug (with 120 Ohm) in the last fixture in order to ensure proper transmission on the DMX data link.

Display Off after 10 seconds

When no button is pressed for 10 seconds, the display will turn off. To light up the display, you have to press or turn the MENU control **(03)**. Once you have pressed or turned the control, the display will light up.

Menu Overview

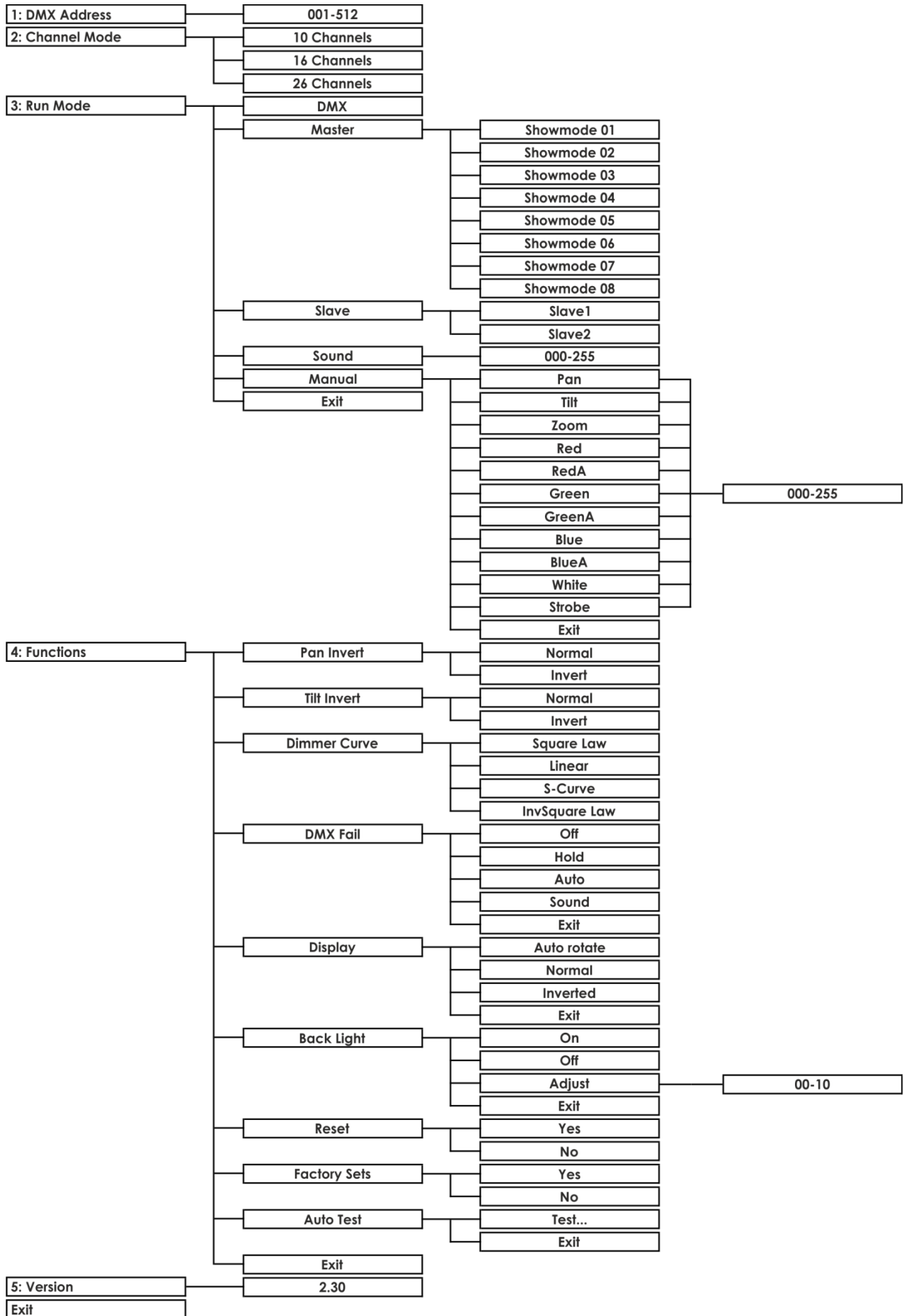

The Phantom 120 Wash will only show its entire version number at start-up !

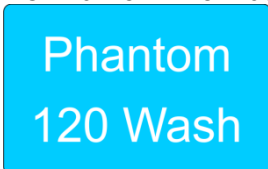

Main Menu Options

There are 5 menu modes:

- 1. DMX Address
- 2. Channel Mode
- 3. Run Mode
- 4. Functions
- 5. Version

1. DMX Address

01) While in main menu, **turn** the MENU control **(03)** until the display shows:



02) **Press** the MENU control **(03)** to enter the menu.

03) The display will show the following screen:

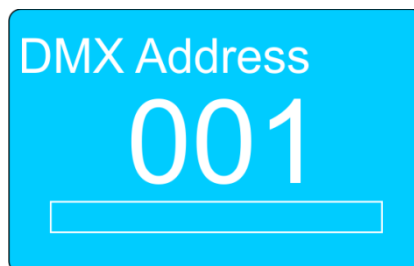

04) **Turn** the MENU control **(03)** to set the desired DMX address.

05) The adjustment range is between 001-512.

06) **Press** the MENU control **(03)** to confirm the DMX address.

2. Channel Mode

01) While in main menu, **turn** the MENU control **(03)** until the display shows:



1 : DMX Address
2 : Channel Mode
3 : Run Mode
4 : Functions

02) **Press** the MENU control **(03)** to enter the menu.

03) **Turn** the MENU control **(03)** to toggle between the 3 available channel modes:

- 10 channels
- 16 channels
- 26 channels

04) **Press** the MENU control **(03)** to choose the desired channel mode.

05) For more information about the DMX channels and their functions, see page 22.

3. Run Mode

01) While in main menu, **turn** the MENU control **(03)** until the display shows:



1 : DMX Address
2 : Channel Mode
3 : Run Mode
4 : Functions

02) **Press** the MENU control **(03)** to enter the menu.

03) **Turn** the MENU control **(03)** to toggle between the 5 available modes:

- DMX
- Master
- Slave
- Sound
- Manual

04) **Press** the MENU control **(03)** to open the mode of your choice.

3.1 DMX Mode

01) **Press** the MENU control **(03)** to confirm the DMX mode.

3.2 Master Mode

01) **Turn** the MENU control **(03)** to choose one of 8 built-in auto shows:

- Showmode 01 – Showmode 08

02) **Press** the MENU control **(03)** to confirm your choice.

03) The device will now run the desired auto show.

3.3 Slave Mode

- 01) **Turn** the MENU control **(03)** to choose one of 2 built-in Slave modes.
- 02) **Turn** the MENU control **(03)** to toggle between the 2 slave functions:
 - Slave1 (normal slave mode)
 - Slave2 (mirror slave mode)
- 03) **Press** the MENU control **(03)** to confirm your preferred slave mode.
- 04) The device is now operating in slave mode and it will react the same as the master device (Slave1), or it will mirror the actions of the master device (Slave2).

3.4 Sound Mode

- 01) **Turn** the MENU control **(03)** to choose Sound and **press** the MENU control **(03)** to enter the menu.
- 02) The display will show the following screen:

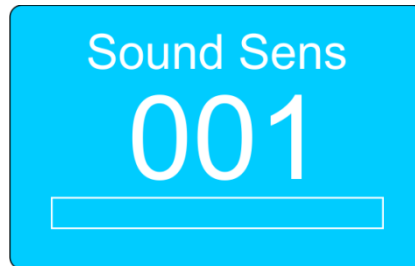

- 03) **Turn** the MENU control **(03)** to adjust the sound sensitivity of the device. The adjustment range is between 000-255, from low to high sensitivity.
- 04) **Press** the MENU control **(03)** to confirm the changes.

3.5 Manual Mode

- 01) **Turn** the MENU control **(03)** to toggle between the 11 available functions:
 - Pan (Pan adjustment)
 - Tilt (Tilt adjustment)
 - Zoom (Zoom adjustment)
 - Red (Red LED intensity)
 - RedA (Red Aura LED intensity)
 - Green (Green LED intensity)
 - GreenA (Green Aura LED intensity)
 - Blue (Blue LED intensity)
 - BlueA (Blue Aura LED intensity)
 - White (White LED intensity)
 - Strobe (Strobe intensity)
- 02) The adjustment range of each function is between 000-255.
- 03) Once the value has been set, **press** the MENU control **(03)** to confirm the changes.
- 04) **Turn** the MENU control **(03)** to choose EXIT.

4. Functions Mode

01) While in main menu, **turn** the MENU control **(03)** until the display shows:



1 : DMX Address
2 : Channel Mode
3 : Show Mode
4 : Functions

02) **Press** the MENU control **(03)** to enter the menu.

03) **Turn** the MENU control **(03)** to toggle between the 9 available functions:

- Pan Invert
- Tilt Invert
- Dimmer Curve
- DMX Fail
- Display
- Back Light
- Reset
- Factory Sets
- Auto Test

4.1 Pan Invert

01) **Press** the MENU control **(03)** to enter the menu.

02) **Turn** the MENU control **(03)**, choose Normal and **press** the MENU control **(03)** to deactivate pan inversion.

03) **Turn** the MENU control **(03)**, choose Invert and **press** the MENU control **(03)** to activate pan inversion.

04) **Press** the MENU control **(03)** to confirm the changes.

4.2 Tilt Invert

01) **Press** the MENU control **(03)** to enter the menu.

02) **Turn** the MENU control **(03)**, choose Normal and **press** the MENU control **(03)** to deactivate tilt inversion.

03) **Turn** the MENU control **(03)**, choose Invert and **press** the MENU control **(03)** to activate tilt inversion.

04) **Press** the MENU control **(03)** to confirm the changes.

4.3 Dimmer Curve

- 01) **Press** the MENU control **(03)** to enter the menu.
- 02) **Turn** the MENU control **(03)** to toggle between the 4 available modes:
 - Square Law
 - Linear
 - S-curve
 - InvSquare Law

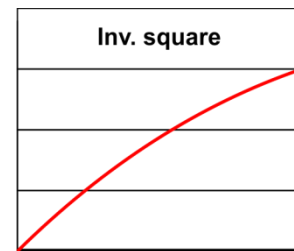
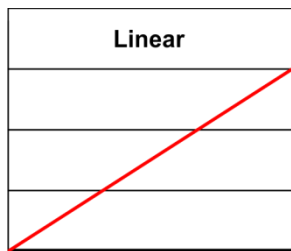
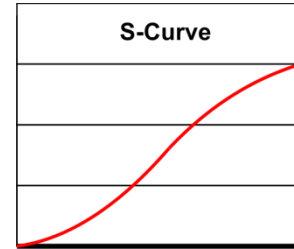
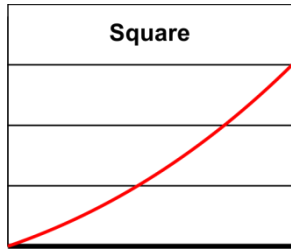

- 03) **Press** the MENU control **(03)** to confirm the mode of your choice.

4.4 DMX Fail Curve

With this menu you can determine the behaviour of the Phantom in case of DMX failure.

- 01) **Press** the MENU control **(03)** to enter the menu.
- 02) **Turn** the MENU control **(03)** to toggle between the 4 available modes:
 - Off (DMX signal lost, device stops)
 - Hold (DMX signal lost, device will memorize the last successfully received DMX signal and will continue using it until DMX signal reception is restored)
 - Auto (DMX signal lost, device starts an auto program)
 - Sound (DMX signal lost, device becomes sound active)
- 03) **Press** the MENU control **(03)** to confirm the mode of your choice.

4.5 Display

- 01) **Press** the MENU control **(03)** to enter the menu.
- 02) **Turn** the MENU control **(03)** to toggle between the 3 options:
 - Auto Rotate (Display flips accordingly to the position of the fixture)
 - Normal
 - Inverted (horizontal flip)
- 03) **Press** the MENU control **(03)** to confirm the mode of your choice.

4.6 Back Light

- 01) **Press** the MENU control **(03)** to enter the menu.
- 02) **Turn** the MENU control **(03)** to toggle between the 3 options:
 - ON (Display continuously ON)
 - OFF (Display turns OFF after 10 seconds)
 - Adjust (Display brightness)
- 04) **Turn** the MENU control **(03)** to choose Adjust and **press** the MENU control **(03)** to enter the menu.
- 05) The display will show the following screen:

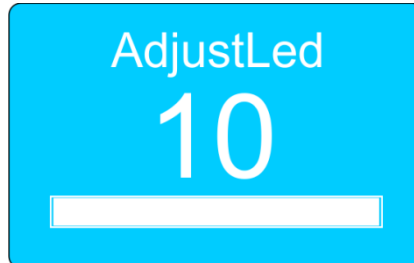

- 06) **Turn** the MENU control **(03)** to adjust the brightness. The adjustment range is between 00-10, from dark to brightest.
- 07) **Press** the MENU control **(03)** to confirm the changes.

4.7 Reset

- 03) **Press** the MENU control **(03)** to enter the menu.
- 04) **Turn** the MENU control **(03)**, choose Yes and **press** the MENU control **(03)** to reset the Phantom.
- 05) **Turn** the MENU control **(03)**, choose No and **press** the MENU control **(03)** to cancel the reset function.
- 06) **Press** the MENU control **(03)** to confirm the changes.

4.8 Factory Sets

- 01) **Press** the MENU control **(03)** to enter the menu.
- 02) **Turn** the MENU control **(03)**, choose Yes and **press** the MENU control **(03)** to restore the factory default settings.
- 03) **Turn** the MENU control **(03)**, choose No and **press** the MENU control **(03)** to return to the main menu.
- 04) **Press** the MENU control **(03)** to confirm the changes.

4.9 Auto Test

- 01) **Press** the MENU control **(03)** to enter the menu.
- 02) **Turn** the MENU control **(03)**, choose Test and **press** the MENU control **(03)** to perform a full test of all the available functions.
- 03) **Turn** the MENU control **(03)**, choose Exit and **press** the MENU control **(03)** to return to the main menu.
- 04) **Press** the MENU control **(03)** to confirm the changes.

5. Version

- 01) **Press** the MENU control **(03)** to enter the menu.
- 02) The display is now showing the current software version, installed on the Phantom:



DMX Channels

10 Channels

Channel 1 – Horizontal movement (Pan)

Push the slider up, in order to move head horizontally (PAN).

Gradual head adjustment, between 0-127. Continuous Clockwise rotation from fast slow, between 128-191. Continuous Counterclockwise rotation from slow to fast, between 192-255.

The head can be turned by 540° and stopped at any position you wish.

Channel 2 – Vertical movement (Tilt)

Push the slider, up in order to move head vertically (TILT).

Gradual head adjustment, between 0-127. Continuous Clockwise rotation from fast slow, between 128-191. Continuous Counterclockwise rotation from slow to fast, between 192-255.

The head can be turned by 270° and stopped at any position you wish.

Channel 3 – Dimmer (CH4 must be open)

0-255 From dark to brightest

Channel 4 – Strobe (CH3 must be open)

0-7 Off

8-119 Random strobe intensity, from slow to fast

120-231 Linear strobe intensity, from slow to fast

Channel 5 – Color Macro

0-7 No function

8-13 Color1 (R255, G000, B000, W000)

14-20 Color2 (R255, G000, B000, W100)

21-27 Color3 (R255, G000, B000, W200)

28-34 Color4 (R255, G050, B000, W000)

35-41 Color5 (R255, G150, B000, W000)

42-48 Color6 (R255, G255, B000, W000)

49-55 Color7 (R255, G255, B000, W075)

56-62 Color8 (R000, G255, B000, W255)

63-69 Color9 (R000, G255, B000, W150)

70-76 Color10 (R000, G255, B000, W050)

77-83 Color11 (R000, G255, B000, W000)

84-90 Color12 (R000, G255, B050, W000)

91-97 Color13 (R000, G255, B150, W000)

98-104 Color14 (R000, G255, B255, W000)

105-111 Color15 (R000, G255, B255, W075)

112-118 Color16 (R000, G255, B255, W150)

119-125 Color17 (R000, G100, B255, W255)

126-132 Color18 (R000, G000, B255, W100)

133-139 Color19 (R000, G000, B255, W050)

140-146 Color20 (R000, G000, B255, W000)

147-153 Color21 (R075, G000, B255, W000)

154-160 Color22 (R160, G000, B255, W000)

161-167 Color23 (R255, G000, B255, W000)

168-174 Color24 (R255, G000, B175, W000)

175-181 Color25 (R255, G000, B100, W000)

182-188 Color26 (R255, G000, B100, W050)

189-195 Color27 (R255, G000, B025, W050)

196-202 Color28 (R255, G000, B025, W025)

203-209 Color29 (R255, G000, B025, W000)

210-216 Color30 (R000, G000, B000, W255)

217-223	Color31 (R075, G075, B000, W255)
224-230	Color32 (R000, G000, B100, W255)
231-255	Color33 (R255, G255, B255, W255)

Channel 6 – Aura Color

0-7	No function
8-19	Color1 (R255, G000, B000)
20-39	Color2 (R255, G150, B000)
40-59	Color3 (R255, G255, B000)
60-79	Color4 (R000, G255, B000)
80-99	Color5 (R000, G255, B150)
100-119	Color6 (R000, G255, B255)
120-139	Color7 (R000, G000, B255)
140-159	Color8 (R160, G000, B255)
160-179	Color9 (R255, G000, B255)
180-199	Color10 (R255, G000, B175)
200-219	Color11 (R255, G255, B100)
220-239	Color12 (R255, G000, B025)
240-255	Color13 (R255, G255, B255)

Channel 7 – Color Flow

0-15	No function
16-31	Color Jump1
32-47	Color Jump2
48-63	Color Jump3
64-79	Color Jump4
80-95	Color Jump5
96-111	Color Jump6
112-127	Color Jump7
128-143	Color Jump8
144-159	Color Fade1
160-175	Color Fade2
176-191	Color Fade3
192-207	Color Fade4
208-223	Color Fade5
224-239	Color Fade6
240-255	Color Fade7

Channel 8 – Color Flow Speed

0-255	From slow to fast
-------	-------------------

Channel 9 – Zoom

0-255	From narrow to wide
-------	---------------------

Channel 10 – Functions

0-5	No function
6-10	Show1
11-20	Show2
21-30	Show3
31-40	Show4
41-50	Show5
51-60	Show6
61-70	Show7
71-80	Show8
81-90	Slave1
91-96	Slave2

97-160	Sound sensitivity from low sensitivity to high sensitivity
161-170	Pan invert
171-180	Tilt invert
181-190	Pan normal
191-200	Tilt normal
201-220	Blackout during pan/tilt movement
221-240	Reset (after 3 seconds)
241-255	No function

16 Channels

Channel 1 – Horizontal movement (Pan)

Push the slider up, in order to move head horizontally (PAN).

Gradual head adjustment, between 0-255.

The head can be turned by 540° and stopped at any position you wish.

Channel 2 – Pan fine 16 bit

Channel 3 – Vertical movement (Tilt)

Push the slider, up in order to move head vertically (TILT).

Gradual head adjustment, between 0-255.

The head can be turned by 270° and stopped at any position you wish.

Channel 4 – Tilt fine 16 bit

Channel 5 – Pan / Tilt speed

0-255 From Max Speed (0) to Min. Speed (255)

Channel 6 – Pan continuous rotation

0-15 Off

16-135 Forwards continuous rotation, from fast to slow

136-255 Backwards continuous rotation, from slow to fast

Channel 7 – Tilt continuous rotation

0-15 Off

16-135 Forwards continuous rotation, from fast to slow

136-255 Backwards continuous rotation, from slow to fast

Channel 8 – Dimmer (CH9 must be open)

0-255 From dark to brightest

Channel 9 – Shutter/Linear Strobe CH8 must be open

0-10 Off

11-255 Strobe intensity, from slow to fast

Channel 10 – Shutter/Random Strobe (CH8 must be open

0-10 Off

11-255 Strobe intensity, from slow to fast

Channel 11 – Zoom

0-255 From narrow to wide

Channel 12 – Functions

0-5	No function
6-10	Show1
11-20	Show2
21-30	Show3
31-40	Show4
41-50	Show5
51-60	Show6
61-70	Show7
71-80	Show8
81-90	Slave1
91-96	Slave2
97-160	Sound sensitivity from low sensitivity to high sensitivity
161-170	Pan invert
171-180	Tilt invert
181-190	Pan normal
191-200	Tilt normal
201-220	Black out during pan/ tilt movement
221-240	Reset (after 3 seconds)
241-255	No function

Channel 13 – Red color intensity (CH8+CH9/CH10 must be open)

0-255 Gradual adjustment Red from 0 – 100%

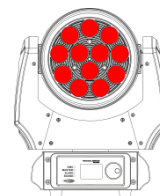

Channel 14 – Green color intensity (CH8+CH9/CH10 must be open)

0-255 Gradual adjustment Green from 0 – 100%

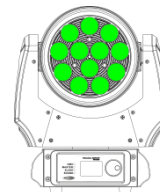

Channel 15 – Blue color intensity (CH8+CH9/CH10 must be open)

0-255 Gradual adjustment Blue from 0 – 100%

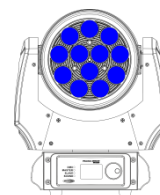

Channel 16 – White color intensity (CH8+CH9/CH10 must be open)

0-255 Gradual adjustment White from 0 – 100%

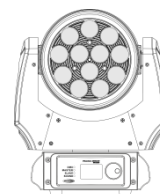

26 Channels

Channel 1 – Horizontal movement (Pan)

Push the slider up, in order to move head horizontally (PAN).

Gradual head adjustment, between 0-255.

The head can be turned by 540° and stopped at any position you wish.

Channel 2 – Pan fine 16 bit

Channel 3 – Vertical movement (Tilt)

Push the slider, up in order to move head vertically (TILT).

Gradual head adjustment, between 0-255.

The head can be turned by 270° and stopped at any position you wish.

Channel 4 – Tilt fine 16 bit

Channel 5 – Pan / Tilt speed

0-255 From Max Speed (0) to Min. Speed (255)

Channel 6 – Pan continuous rotation

0-15 Off

16-135 Forwards continuous rotation, from fast to slow

136-255 Backwards continuous rotation, from slow to fast

Channel 7 – Tilt continuous rotation

0-15 Off

16-135 Forwards continuous rotation, from fast to slow

136-255 Backwards continuous rotation, from slow to fast

Channel 8 – Dimmer (CH9 must be open)

0-255 From dark to brightest

Channel 9 – Linear Strobe (CH8 must be open)

0-10 Off

11-255 Strobe intensity, from slow to fast

Channel 10 – Random Strobe (CH8 must be open)

0-10 Off

11-255 Strobe intensity, from slow to fast

Channel 11 – Dimmer Aura (CH12 must be open)

0-255 From dark to brightest

Channel 12 – Aura Strobe (CH11 must be open)

0-10 Off

11-255 Strobe intensity, from slow to fast

Channel 13 – Aura Random Strobe (CH11 must be open)

0-10 Off

11-255 Strobe intensity, from slow to fast

Channel 14 – Color Macro (CH14 has priority over CH23, CH24, CH25, CH26)

0-7	No function
8-13	Color1(R255, G000, B000, W000)
14-20	Color2(R255, G000, B000, W100)
21-27	Color3(R255, G000, B000, W200)
28-34	Color4(R255, G050, B000, W000)
35-41	Color5(R255, G150, B000, W000)
42-48	Color6(R255, G255, B000, W000)
49-55	Color7(R255, G255, B000, W075)
56-62	Color8(R000, G255, B000, W255)
63-69	Color9(R000, G255, B000, W150)
70-76	Color10(R000, G255, B000, W050)
77-83	Color11(R000, G255, B000, W000)
84-90	Color12(R000, G255, B050, W000)
91-97	Color13(R000, G255, B150, W000)
98-104	Color14(R000, G255, B255, W000)
105-111	Color15(R000, G255, B255, W075)
112-118	Color16(R000, G255, B255, W150)
119-125	Color17(R000, G100, B255, W255)
126-132	Color18(R000, G000, B255, W100)
133-139	Color19(R000, G000, B255, W050)
140-146	Color20(R000, G000, B255, W000)
147-153	Color21(R075, G000, B255, W000)
154-160	Color22(R160, G000, B255, W000)
161-167	Color23(R255, G000, B255, W000)
168-174	Color24(R255, G000, B175, W000)
175-181	Color25(R255, G000, B100, W000)
182-188	Color26(R255, G000, B100, W050)
189-195	Color27(R255, G000, B025, W050)
196-202	Color28(R255, G000, B025, W025)
203-209	Color29(R255, G000, B025, W000)
210-216	Color30(R000, G000, B000, W255)
217-223	Color31(R075, G075, B000, W255)
224-230	Color32(R000, G000, B100, W255)
231-255	Color33(R255, G255, B255, W255)

Channel 15 – Aura Color

0-7	No function
8-19	Color1 (R255, G000, B000)
20-39	Color2 (R255, G150, B000)
40-59	Color3 (R255, G255, B000)
60-79	Color4 (R000, G255, B000)
80-99	Color5 (R000, G255, B150)
100-119	Color6 (R000, G255, B255)
120-139	Color7 (R000, G000, B255)
140-159	Color8 (R160, G000, B255)
160-179	Color9 (R255, G000, B255)
180-199	Color10 (R255, G000, B175)
200-219	Color11 (R255, G255, B100)
220-239	Color12 (R255, G000, B025)
240-255	Color13 (R255, G255, B255)

Channel 16 – Color Flow (CH16 has priority over CH23, CH24, CH25, CH26)

0-15	No function
16-31	Color Jump1
32-47	Color Jump2
48-63	Color Jump3
64-79	Color Jump4
80-95	Color Jump5
96-111	Color Jump6
112-127	Color Jump7
128-143	Color Jump8
144-159	Color Fade1
160-175	Color Fade2
176-191	Color Fade3
192-207	Color Fade4
208-223	Color Fade5
224-239	Color Fade6
240-255	Color Fade7

Channel 17 – Color Flow Speed

0-255	From slow to fast
-------	-------------------

Channel 18 – Zoom

0-255	From narrow to wide
-------	---------------------

Channel 19 – Functions

0-5	No function
6-10	Show1
11-20	Show2
21-30	Show3
31-40	Show4
41-50	Show5
51-60	Show6
61-70	Show7
71-80	Show8
81-90	Slave1
91-96	Slave2
97-160	Sound sensitivity from low sensitivity to high sensitivity
161-170	Pan invert
171-180	Tilt invert
181-190	Pan normal
191-200	Tilt normal
201-220	Black out during pan/ tilt movement
221-240	Reset (after 3 seconds)
241-255	No function

Channel 20 – Aura Red color intensity (CH11+CH12 must be open)

0-255	Gradual adjustment Red from 0 – 100%
-------	--------------------------------------

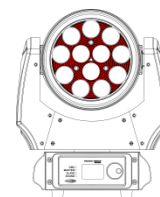

Channel 21 – Aura Green color intensity (CH11+CH12 must be open )

0-255 Gradual adjustment Green from 0 – 100%

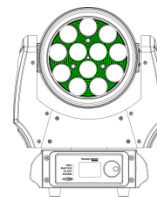

Channel 22 – Aura Blue color intensity (CH11+CH12 must be open )

0-255 Gradual adjustment Blue from 0 – 100%

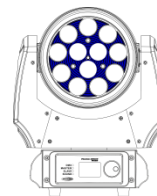

Channel 23 – Red color intensity (CH8+CH9/CH10 must be open )

0-255 Gradual adjustment Red from 0 – 100%

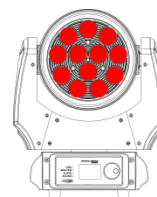

Channel 24 – Green color intensity (CH8+CH9/CH10 must be open )

0-255 Gradual adjustment Green from 0 – 100%

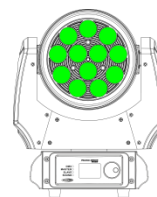

Channel 25 – Blue color intensity (CH8+CH9/CH10 must be open )

0-255 Gradual adjustment Blue from 0 – 100%

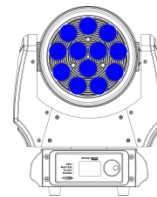

Channel 26 – White color intensity (CH8+CH9/CH10 must be open )

0-255 Gradual adjustment White from 0 – 100%

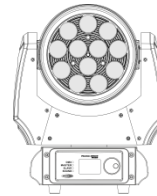

Maintenance

The Showtec Phantom 120 Wash RGBW requires almost no maintenance. However, you should keep the unit clean. Otherwise, the fixture's light-output will be significantly reduced. Disconnect the mains power supply and then wipe the cover with a damp cloth. Wipe the front glass panel clean with glass cleaner and a soft cloth. Do not use alcohol or solvents. The front glass panel will require weekly cleaning, as smoke-fluid tends to build up residues, reducing the light-output very quickly. Do not immerse in liquid. Keep connections clean. Disconnect electric power, and then wipe the DMX and audio connections with a damp cloth. Make sure connections are thoroughly dry before linking equipment or supplying electric power.

The operator has to make sure that safety-relating and machine-technical installations are to be inspected by an expert after every year in the course of an acceptance test.

The operator has to make sure that safety-relating and machine-technical installations are to be inspected by a skilled person once a year.

The following points have to be considered during the inspection:

- 01) All screws used for installing the device or parts of the device have to be tightly connected and must not be corroded.
- 02) There may not be any deformations on housings, fixations and installation spots.
- 03) Mechanically moving parts like axles, eyes and others may not show any traces of wearing.
- 04) The electric power supply cables must not show any damages or material fatigue.

Replacing the Fuse

Power surges, short-circuit or inappropriate electrical power supply may cause a fuse to burn out. If the fuse burns out, the product will not function whatsoever. If this happens, follow the directions below to do so.

- 01) Unplug the unit from electric power source.
- 02) Insert a screwdriver into the slot in the fuse cover. Turn the fuse holder counterclockwise. The fuse will come out.
- 03) Remove the used fuse. If brown or unclear, it is burned out.
- 04) Insert the replacement fuse into the holder where the old fuse was. Reinsert the fuse holder. Be sure to use a fuse of the same type and specification. See the product specification label for details.

Troubleshooting

No Light

This troubleshooting guide is meant to help solve simple problems.

If a problem occurs, carry out the steps below in sequence until a solution is found. Once the unit operates properly, do not carry out following steps.

If the light effect does not operate properly, refer servicing to a technician.

Response: Suspect three potential problem areas as: the power supply, the LED, the fuse.

- 01) Power supply. Check if the unit is plugged into an appropriate power supply.
- 02) The LEDs. Return the Phantom 120 Wash RGBW to your Showtec dealer.
- 03) The fuse. See page 29 for replacing the fuse.
- 04) If all of the above appears to be O.K., plug the unit in again.
- 05) If you are unable to determine the cause of the problem, do not open the Phantom 120 Wash RGBW, as this may damage the unit and the warranty will become void.
- 06) Return the device to your Showtec dealer.

No Response to DMX

Response: Suspect the DMX cable or connectors, a controller malfunction, a light effect DMX card malfunction.

- 01) Check the DMX setting. Make sure that DMX addresses are correct.
- 02) Check the DMX cable: Unplug the unit; change the DMX cable; then reconnect to electrical power. Try your DMX control again.
- 03) Determine whether the controller or light effect is at fault. Does the controller operate properly with other DMX products? If not, take the controller in for repair. If so, take the DMX cable and the light effect to a qualified technician.

Problem	Probable cause(s)	Solution
One or more fixtures do not function at all	No power to the fixture	<ul style="list-style-type: none"> • Check if power is switched on and cables are plugged in
	Primary fuse blown	<ul style="list-style-type: none"> • Replace fuse
Fixtures reset correctly, but all respond erratically or not at all to the controller	The controller is not connected.	<ul style="list-style-type: none"> • Connect controller.
	3-pin XLR Out of the controller does not match XLR Out of the first fixture on the link (i.e. signal is reversed)	<ul style="list-style-type: none"> • Install a phase reversing cable between the controller and the first fixture on the link
Fixtures reset correctly, but some respond erratically or not at all to the controller	Poor data quality	<ul style="list-style-type: none"> • Check data quality. If much lower than 100 percent, the problem may be a bad data link connection, poor quality or broken cables, missing termination plug, or a defective fixture disturbing the link
	Bad data link connection	<ul style="list-style-type: none"> • Inspect connections and cables. Correct poor connections. Repair or replace damaged cables
	Data link not terminated with 120 Ohm termination plug	<ul style="list-style-type: none"> • Insert termination plug in output jack of the last fixture on the link
	Incorrect addressing of the fixtures	<ul style="list-style-type: none"> • Check address setting
	One of the fixtures is defective and disturbs data transmission on the link	<ul style="list-style-type: none"> • Bypass one fixture at a time until normal operation is restored: unplug both connectors and connect them directly together. • Have the defective fixture serviced by a qualified technician
	3-pin XLR Out on the fixtures does not match (pins 2 and 3 reversed)	<ul style="list-style-type: none"> • Install a phase-reversing cable between the fixtures or swap pin 2 and 3 in the fixture that behaves erratically
Shutter closes suddenly	The color wheel, gobo wheel or a gobo has lost its index position and the fixture is resetting the effect	<ul style="list-style-type: none"> • Contact a technician for servicing if the problem persists
No light or lamp cuts out intermittently	Fixture is too hot	<ul style="list-style-type: none"> • Allow the fixture to cool down • Clean the fan • Make sure air vents in control panel and the front lens are not blocked • Turn up the air conditioning
	LEDs damaged	<ul style="list-style-type: none"> • Disconnect the fixture and return it to your dealer
	The power supply settings do not match local AC voltage and frequency	<ul style="list-style-type: none"> • Disconnect fixture. Check settings and correct if necessary

Product Specifications

Model:	Showtec Phantom 70 Beam RGBW
Input Voltage:	100-240 VAC, 60/50Hz
Power consumption:	135W max. at full output
DMX linking:	30pcs
Fuse:	T3A/250V
Dimensions:	309 x 152 x 385 mm (LxWxH)
Weight:	6,9 kg
Operating and Programming:	
Signal pin OUT:	Pin 1 (earth), pin 2 (-), pin 3 (+)
DMX Mode:	10, 16, 26
Signal input:	3-pin XLR male
Signal output:	3-pin XLR female
Electro-mechanical effects:	
LED Quantity:	12 x 10W RGBW 4-in-1 LEDs
Backlight System:	21 x RGB 5050 SMD
Colormixing:	RGBW
Beam angle:	5° - 60°
Clear Lens with RGB backlight	
Continuous Pan & Tilt	
Motorized Zoom	
Pan / Tilt range	540° / 270°
Dimmer: 0-100%	0-100%, electronic dimmer
Strobe: 0-20Hz	0-20Hz
DMX-control:	via standard DMX-controller
On Board:	LCD display for easy setup
Control:	Auto, Manual, Sound-controlled, Master/Slave, DMX512
Housing:	Black Metal & Flame-retardant plastic
PowerConnections:	Blue Pro Power connector IN and Grey Pro Power connector OUT
Data Connections	3-pin DMX IN and OUT
Dimmer curves:	Linear, Square, I-Square, S curve
Special:	Pan/ Tilt reverse & Black out by DMX
IFS Technology	
On-Board:	Display including gravity sensor
Lux @ 2m:	14300lux (5°)
Cooling:	Internal fans
Working temperature:	-10°C~40°C
Included:	Schuko to Pro Power connector cable (length 1,5 m) and mounting bracket
Max. ambient temperature t_a : 40°C	Max. housing temperature t_b : 80°C
Minimum distance:	
Minimum distance from flammable surfaces:	0,5 m
Minimum distance to lighted object:	1 m

Design and product specifications are subject to change without prior notice.



Website: www.Showtec.info

Email: service@highlite.nl

Dimensions

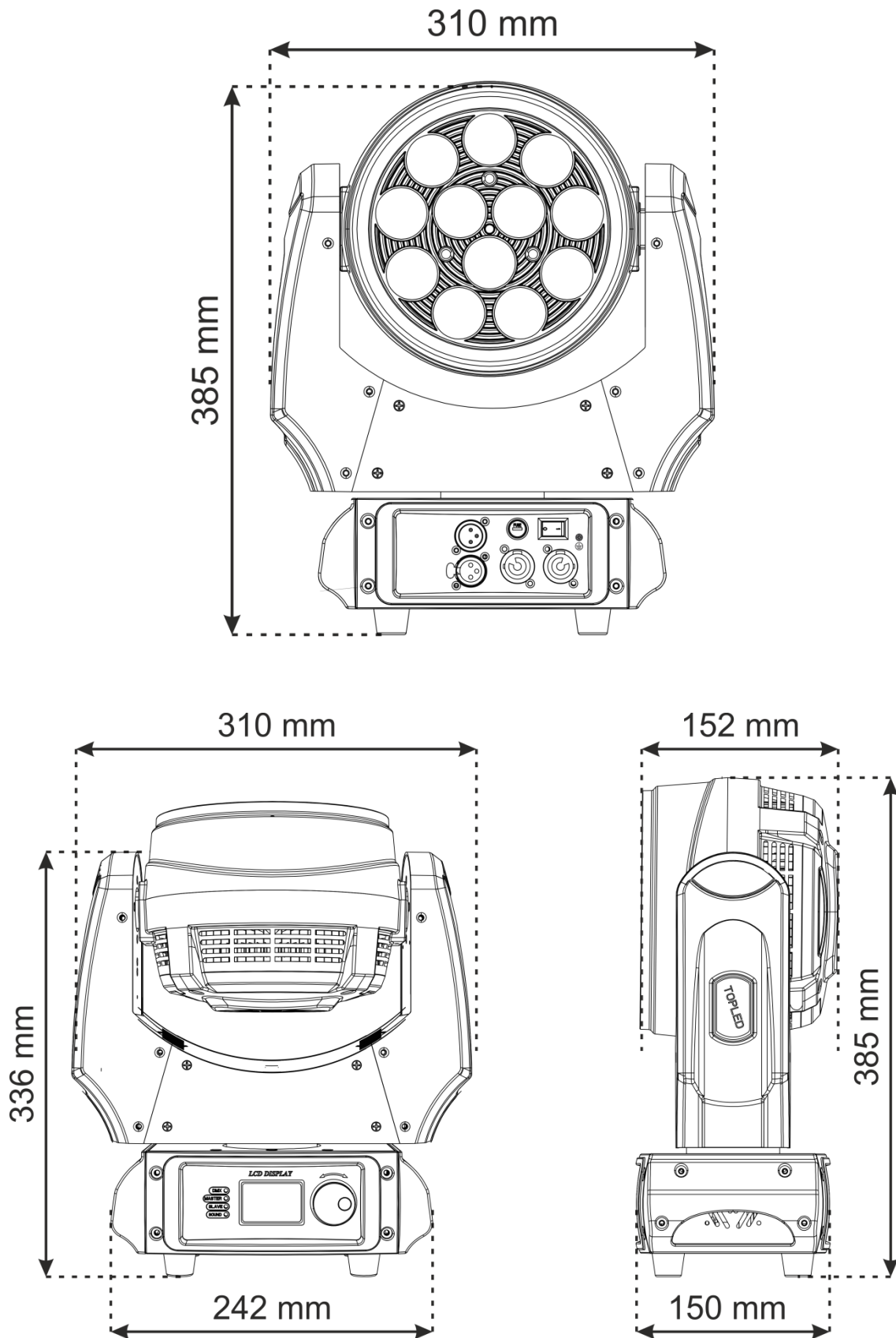



©2016 Showtec