



freeU HT, freeU PT
UHF wireless system

Musikhaus Thomann
Thomann GmbH
Hans-Thomann-Straße 1
96138 Burgebrach
Germany
Telephone: +49 (0) 9546 9223-0
E-mail: info@thomann.de
Internet: www.thomann.de

21.02.2017, ID: 405079, 405080, 405081, 405082, 405083, 405084

Table of contents

1	General notes	5
	1.1 Further information.....	6
	1.2 Notational conventions.....	7
	1.3 Symbols and signal words.....	8
2	Safety instructions	10
3	Features	14
4	Installation and starting up	16
	4.1 General Information.....	16
	4.2 Receiver.....	17
	4.3 Handheld microphone (HT series).....	19
	4.4 Bodypack transmitter (PT series).....	19
5	Connections and controls	21
	5.1 Receiver.....	21
	5.2 Handheld microphone.....	28
	5.3 Bodypack transmitter.....	31

6	Operating.....	34
6.1	Receiver.....	34
6.2	Bodypack transmitter.....	35
7	Technical specifications.....	37
7.1	Receiver.....	37
7.2	Handheld microphone.....	38
7.3	Bodypack transmitter.....	40
8	Plug and connection assignment.....	42
9	Troubleshooting.....	45
10	Protecting the environment.....	48

1 General notes

This manual contains important instructions for the safe operation of the unit. Read and follow the safety instructions and all other instructions. Keep the manual for future reference. Make sure that it is available to all those using the device. If you sell the unit please make sure that the buyer also receives this manual.

Our products are subject to a process of continuous development. Thus, they are subject to change.

1.1 Further information

On our website (www.thomann.de) you will find lots of further information and details on the following points:

Download	This manual is also available as PDF file for you to download.
Keyword search	Use the search function in the electronic version to find the topics of interest for you quickly.
Online guides	Our online guides provide detailed information on technical basics and terms.
Personal consultation	For personal consultation please contact our technical hotline.
Service	If you have any problems with the device the customer service will gladly assist you.

1.2 Notational conventions

This manual uses the following notational conventions:

Letterings

The letterings for connectors and controls are marked by square brackets and italics.

Examples: *[VOLUME]* control, *[Mono]* button.

Displays

Texts and values displayed on the device are marked by quotation marks and italics.

Examples: *'24ch'*, *'OFF'*.

Instructions

The individual steps of an instruction are numbered consecutively. The result of a step is indented and highlighted by an arrow.

Example:

- 1.** ▶ Switch on the device.
- 2.** ▶ Press *[Auto]*.
⇒ Automatic operation is started.
- 3.** ▶ Switch off the device.

1.3 Symbols and signal words

In this section you will find an overview of the meaning of symbols and signal words that are used in this manual.

Signal word	Meaning
DANGER!	This combination of symbol and signal word indicates an immediate dangerous situation that will result in death or serious injury if it is not avoided.
NOTICE!	This combination of symbol and signal word indicates a possible dangerous situation that can result in material and environmental damage if it is not avoided.
Warning signs	Type of danger
	Warning – danger zone.

2 Safety instructions

Intended use

This device is intended to be used for the wireless transmission of audio signals from microphones or instruments to amplifiers or active speakers. Use the device only as described in this user manual. Any other use or use under other operating conditions is considered to be improper and may result in personal injury or property damage. No liability will be assumed for damages resulting from improper use.

This device may be used only by persons with sufficient physical, sensorial, and intellectual abilities and having corresponding knowledge and experience. Other persons may use this device only if they are supervised or instructed by a person who is responsible for their safety.

Safety



DANGER!

Danger for children

Ensure that plastic bags, packaging, etc. are disposed of properly and are not within reach of babies and young children. Choking hazard!

Ensure that children do not detach any small parts (e.g. knobs or the like) from the unit. They could swallow the pieces and choke!

Never let children unattended use electrical devices.



NOTICE!

Operating conditions

This device has been designed for indoor use only. To prevent damage, never expose the device to any liquid or moisture. Avoid direct sunlight, heavy dirt, and strong vibrations.



NOTICE!

External power supply

The device is powered by an external power supply. Before connecting the external power supply, ensure that the input voltage (AC outlet) matches the voltage rating of the device and that the AC outlet is protected by a residual current circuit breaker. Failure to do so could result in damage to the device and possibly the user.

Unplug the external power supply before electrical storms occur and when the device is unused for long periods of time to reduce the risk of electric shock or fire.



NOTICE!

Risk of fire due to incorrect polarity

Incorrectly inserted batteries may destroy the device or the batteries.

Ensure that proper polarity is observed when inserting batteries.



NOTICE!

Possible damage by leaking batteries

Leaking batteries can cause permanent damage to the device.

Take batteries out of the device if it is not going to be used for a longer period.

3 Features

The UHF wireless system is particularly suitable for professional audio transmission, for example, at events, on rock stages and in concert halls, theatres, musicals or night clubs.

The UHF Wireless System freeU HT is comprised of the following components:

- 9.5" Diversity receiver
 - Two antennas for optimum reception quality
 - Infrared interface for sending the frequency selection from the receiver to the transmitter
 - Outputs: XLR, 1/4" phone socket
 - solid metal housing, 9.5" rack mountable (1 RU)
 - Power supply: AC 12 V $\overline{\text{---}}$
- Transmitter: battery powered handheld super cardioid microphone
- Two antennas, a suitable power supply, an installation kit for the rack mounting of a receiver and a microphone holder are included

The UHF Wireless System freeU PT is comprised of the following components:

- 9.5" Diversity receiver
 - Two antennas for optimum reception quality
 - Infrared interface for sending the frequency selection from the receiver to the transmitter
 - Outputs: XLR, 1/4" phone socket
 - solid metal housing, 9.5" rack mountable (1 RU)
 - Power supply: AC 12 V $\overline{\text{---}}$
- Transmitter:
 - battery powered bodypack transmitter
- Two antennas, a suitable power supply, an installation kit for the rack mounting of a receiver and a microphone holder are included

4 Installation and starting up

4.1 General Information

Unpack and carefully check that there is no transportation damage before using the unit. Keep the equipment packaging. To fully protect the device against vibration, dust and moisture during transportation or storage use the original packaging or your own packaging material suitable for transport or storage, respectively.

Create all connections while the device is off. Use the shortest possible high-quality cables for all connections. Take care when running the cables to prevent tripping hazards.

Notes on wireless transmission

- This device utilizes frequencies that are not harmonized within the European Union (EU) and therefore may only be used in certain EU member states. In all European countries, the frequencies used for the transmission of audio signals are strictly regulated. Before you start, make sure the frequencies are allowed in the respective country and check whether the operation must be reported to the appropriate authority.
For more information, please visit: <http://www.thomann.de>.
- Make sure that transmitter and receiver are both tuned to the same channel.
- Never set multiple transmitters to the same channel.
- Make sure that there are no metal objects between the transmitter and receiver.
- Avoid interference from other radio or in-ear systems.

4.2 Receiver

Rack mounting

The unit has been designed for rack mounting in a standard 9.5" rack; it occupies one rack unit. Two receivers can be installed side-by-side in 19" racks. The fixing material required for assembly is included.

Connecting the power supply



NOTICE!

External power supply

The device is powered by an external power supply. Before connecting the external power supply, ensure that the input voltage (AC outlet) matches the voltage rating of the device and that the AC outlet is protected by a residual current circuit breaker. Failure to do so could result in damage to the device and possibly the user.

Unplug the external power supply before electrical storms occur and when the device is unused for long periods of time to reduce the risk of electric shock or fire.

First, connect the power adapter to the receiver and then plug the power adapter into the power outlet.

Attaching the antennas

Attach the included antennas to the rear panel of the transmitter. To improve the transmission quality and to adapt to the spatial conditions they are rotatable and swivelling.

In case the space provided on the device for direct assembly of the antennas is not sufficient, for example because the space on the rack is narrow, you can use the optionally available coaxial cable to assemble the antennas separately from the device.

Connecting audio and starting up

Connect one of the audio outputs of the receiver to your mixer or your amplifier. Ensure that only one of the two outputs is ever used at a time, because faults might occur otherwise.

4.3 Handheld microphone (HT series)

Inserting batteries

Unscrew the bottom housing section of the hand-held microphone. Insert the batteries. Pay attention to the correct location of the poles. The correct arrangement of the batteries is indicated with symbols in the battery compartment. Close the battery compartment, screw the bottom housing section back on, and switch the transmitter on.

4.4 Bodypack transmitter (PT series)

Inserting batteries

Squeeze the battery compartment lid, flip it open and insert the batteries. Pay attention to the correct location of the poles. Close the battery compartment and switch the transmitter on.

Connecting microphone of instrument

- Ensure that the transmitter is switched off.
- Connect the microphone or instrument cable to the input on the transmitter (mini-XLR panel connector).
- Turn on the transmitter and check the transmission by using the microphone or instrument. If necessary, adjust the amplification of the transmitter and the levels on your mixing console or your amplifier.

5 Connections and controls

5.1 Receiver

Front panel

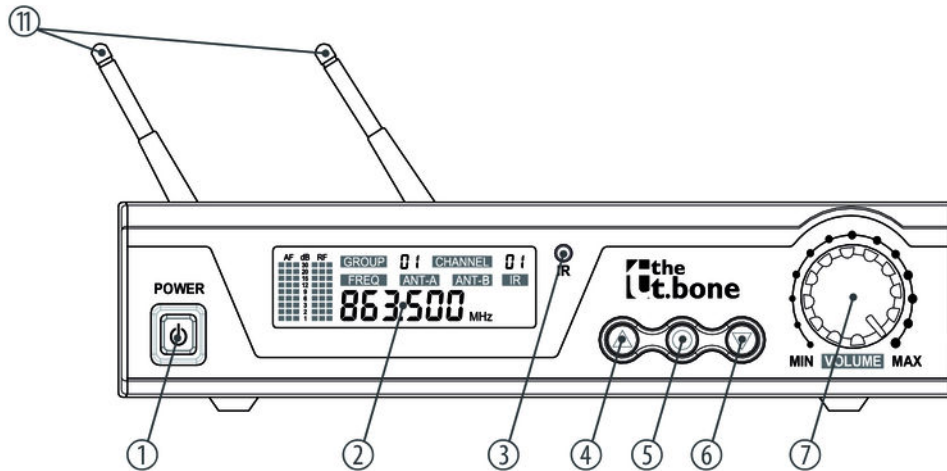

freeU HT, freeU PT

1	<i>[POWER]</i> Press the switch to switch the device on or off. All previous settings are retained even when you switch the device off and disconnect it from the mains.
2	Display
3	<i>[IR]</i> Infrared sensor
4	▲ Increases the displayed value by one.
5	<i>[SET]</i> Opens the menu.
6	▼ Decreases the displayed value by one.

7	<i>[VOLUME]</i> Volume control to adjust the audio output level.
11	UHF antenna

Rear panel

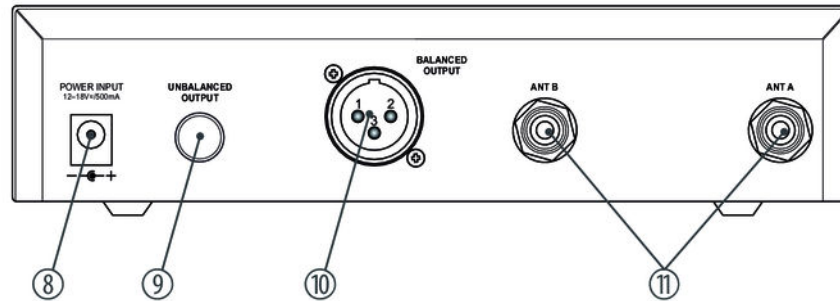

8 [DC INPUT 12-18V]

Socket for connecting the supplied AC power supply. If you are using a different power supply, observe the correct voltage, the polarity of the plug and the power consumption.

9 [UNBALANCED OUTPUT]

1/4" phone socket as unbalanced audio signal output for direct connection to a mixer, a power amplifier or recording device.

10 *[BALANCED OUTPUT]*

Male XLR panel connector as symmetrical audio signal output for direct connection with a mixer, a power amplifier, or a recording device.

11 *[ANT A], [ANT B]*

UHF antenna connections.

Display

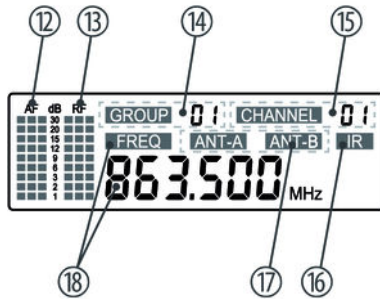

- | | | |
|----|-----------|---|
| 12 | [AF] | Level display for the audio signal. |
| 13 | [RF] | Level indicator for the received radio signal. |
| 14 | [GROUP] | Indicates the selected frequency group. |
| 15 | [CHANNEL] | Indicates the selected channel. |
| 16 | [IR] | Indicates data transfer via infrared interface. |

17 *[ANT-A], [ANT-B]*

Shows which of the two antennas is currently being used for signal transmission.

18 *[FREQ]*

Indicates the frequency that is assigned to the set combination of frequency group and channel.

5.2 Handheld microphone

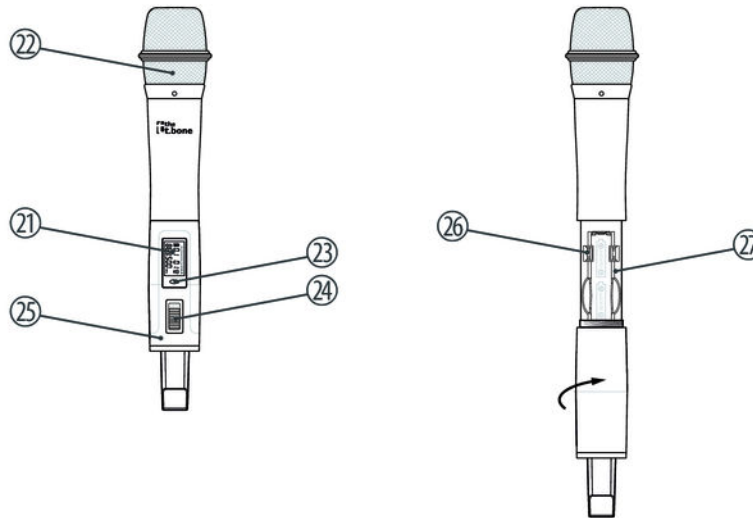

21	Display
22	Microphone head grill to prevent damage and to reduce wind and breath noise.
23	Infrared sensor
24	Main switch Slide the switch all the way forward to turn on the microphone. Slide it all the way back to turn it off. Set the switch to the centre position to mute the microphone.
25	Lower housing part. Unscrew to open.
26	Indicating the frequency range in which the device operates. The specification here must match the specification printed on the back of the receiver.
27	Battery holder for two round cell batteries (AA, LR06), 1.5 V or comparable rechargeable batteries.

Display

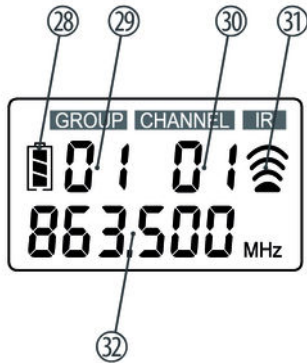

28	Battery level indicator. Replace the batteries when only one blinking bar remains displayed. Reduces the voltage of the batteries even further if the transmitter is automatically switched off.
29	<i>[GROUP]</i> Indicates the selected frequency group.
30	<i>[CHANNEL]</i> Indicates the selected channel.
31	<i>[IR]</i> Indicates data transfer via infrared interface.
32	Indicates the set frequency that is assigned to the set combination of frequency group and channel.

5.3 Bodypack transmitter

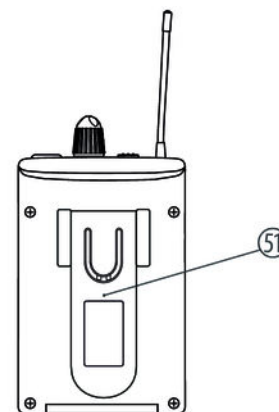
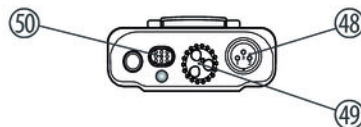
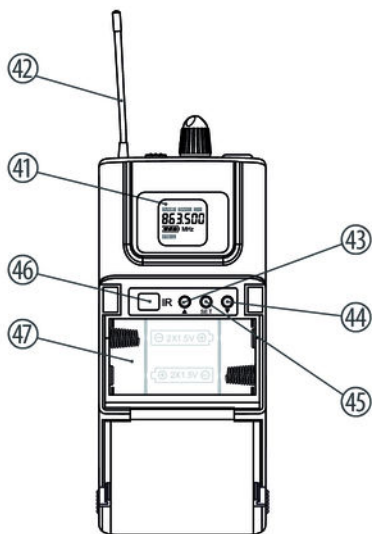

freeU HT, freeU PT

41	Display
42	Antenna
43	▲ Increases the displayed value by one.
44	● Opens the menu.
45	▼ Decreases the displayed value by one.
46	<i>[IR]</i> Infrared sensor
47	Battery holder for two round cell batteries (AA, LR06), 1.5 V or comparable rechargeable batteries.
48	Mini-XLR panel connector for connecting a microphone or instrument.
49	Volume control

50	Main switch Press the switch for several seconds to switch the device on or off.
51	Retaining clamp

Display

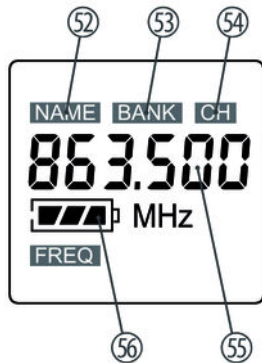

52, 53, 54	[NAME], [BANK], [CH] No function.
55	[FREQ] Indicates the set frequency that is assigned to the set combination of frequency group and channel.
56	Battery level indicator. Replace the batteries when only one blinking bar remains displayed. Reduces the voltage of the batteries even further if the transmitter is automatically switched off.

6 Operating

6.1 Receiver

Selecting frequency

1. ➤ Press ●.
⇒ The *[GROUP]* display flashes.
2. ➤ Use the arrow keys to select the frequency group.
Press ● to confirm the selection.
⇒ The *[CHANNEL]* display flashes.
3. ➤ Use the arrow keys to select a channel within the set frequency group.
Press ● to confirm the selection.
⇒ The *[PO.x]* display flashes.
4. ➤ Use the arrow buttons to select the level for the radio signal in a range from 5 mW (PO.1) to 30 mW (PO.4) (this option is omitted for the t.bone freeU HT 863 and the t.bone freeU PT 863) .

Press ● to confirm the selection.

⇒ The settings are complete.

Synchronizing transmitter and receiver

1. ▶ Turn on the transmitter and open it to uncover the infrared sensor.
2. ▶ Press ● at the receiver for several seconds. The display *[IR]* flashes.
3. ▶ Turn the transmitter off and then straight away back on again. Within ten seconds, hold the infrared sensor of the transmitter near the infrared interface of the receiver.
4. ▶ When synchronization has been successfully completed, the *[IR]* indicator stops flashing and the level display *[RF]* shows a high transmission level.
⇒ After three seconds, the display shows the default state again.

6.2 Bodypack transmitter

The keys for operating the device are located under the flap on the front side.

Select frequency

If you don't want to synchronize the transmitter with the receiver using the infrared interface, you can also set the transmission frequency manually.

- 1.** ▶ Press *[SET]* until the numeric value flashes in the display.
- 2.** ▶ Use the arrow buttons to select the frequency.
Press *[SET]* to confirm the selection.

7 Technical specifications

7.1 Receiver

Output	XLR chassis plug, balanced 1/4" phone socket (unbalanced)
Sensitivity	-110 dBm
NF frequency response	60 Hz... 17 kHz (± 3 dB)
THD	< 0.5 % (1 kHz)
Signal-to-noise ratio	> 105 dB (A) (-60 dBm)
Dynamic range	> 100 dB
Voltage supply	Power adapter (12 V – 18 V $\overline{\text{---}}$ / 500 mA)
Dimensions (W \times H \times D, without antennas)	210 mm \times 44 mm \times 170 mm
Weight	910 g

Carrier frequency, frequency band, number of channels, bandwidth, switching bandwidth and modulation type correspond to those of the transmitter.

7.2 Handheld microphone

Carrier frequency	UHF band (600 MHz...952 MHz)
Frequency band	the t.bone freeU HT 600 (item no. 405081): 606 MHz...630 MHz
	the t.bone freeU HT 823 (item no. 405079): 823 MHz...832 MHz
	the t.bone freeU HT 863 (item no. 405083): 863 MHz...865 MHz
Bandwidth	the t.bone freeU HT 600 (item no. 405081): 14 MHz
	the t.bone freeU HT 823 (item no. 405079): 19 MHz
	the t.bone freeU HT 863 (item no. 405083): 2 MHz
Number of channels	the t.bone freeU HT 600 (item no. 405081): 100 (10 pre-programmed frequency groups, each with 10 channels available)

	the t.bone freeU HT 823 (item no. 405079): 100 (10 pre-programmed frequency groups, each with 10 channels available)
	the t.bone freeU HT 863 (item no. 405083): 16 (4 pre-programmed frequency groups, each with 4 channels available)
Modulation type	Frequency modulation (FM)
Maximum transmission power	10 mW
Spurious response rejection ratio	> 55 dBc
Peak deviation	± 48 kHz
Voltage supply	2 AA cells (LR6, 1.5 V) or corresponding rechargeable batteries
Operating time	> 10 h (with alkaline cells)
Dimensions (L × D)	265 mm × 65 mm
Weight (without batteries)	375 g

7.3 Bodypack transmitter

Carrier frequency	UHF band (600 MHz...952 MHz)
Frequency band	the t.bone freeU PT 600 (item no. 405082): 606 MHz...630 MHz
	the t.bone freeU PT 823 (item no. 405080): 823 MHz...832 MHz
	the t.bone freeU PT 863 (item no. 405084): 863 MHz...865 MHz
Bandwidth	the t.bone freeU PT 600 (item no. 405082): 14 MHz
	the t.bone freeU PT 823 (item no. 405080): 19 MHz
	the t.bone freeU PT 863 (item no. 405084): 2 MHz
Number of channels	the t.bone freeU PT 600 (item no. 405082): 100 (10 pre-programmed frequency groups, each with 10 channels available)
	the t.bone freeU PT 823 (item no. 405080): 100 (10 pre-programmed frequency groups, each with 10 channels available)
	the t.bone freeU PT 863 (item no. 405084): 16 (4 pre-programmed frequency groups, each with 4 channels available)

Modulation type	Frequency modulation (FM)
Maximum transmission power	10 mW
Peak deviation	± 48 kHz
Voltage supply	2 AA cells (LR6, 1.5 V) or corresponding rechargeable batteries
Operating time	> 10 h (with alkaline cells)
Dimensions (W × H × D, without antennas)	63 mm × 110 mm × 21 mm
Weight (without batteries)	88 g

8 Plug and connection assignment

Introduction

This chapter will help you select the right cables and plugs to connect your valuable equipment in such a way that a perfect sound experience is ensured.

Please note these advices, because especially in 'Sound & Light' caution is indicated: Even if a plug fits into the socket, an incorrect connection may result in a destroyed power amp, a short circuit or 'just' in poor transmission quality!

Balanced and unbalanced transmission

Unbalanced transmission is mainly used in semi-professional environment and in hifi use. Instrument cables with two conductors (one core plus shielding) are typical representatives of the unbalanced transmission. One conductor is ground and shielding while the signal is transmitted through the core.

Unbalanced transmission is susceptible to electromagnetic interference, especially at low levels, such as microphone signals and when using long cables.

In a professional environment, therefore, the balanced transmission is preferred, because this enables an undisturbed transmission of signals over long distances. In addition to the conductors 'Ground' and 'Signal', in a balanced transmission a second core is added. This also transfers the signal, but phase-shifted by 180°.

Since the interference affects both cores equally, by subtracting the phase-shifted signals, the interfering signal is completely neutralized. The result is a pure signal without any noise interference.

1/4" TS phone plug (mono, unbalanced)



1	Signal
2	Ground, shielding

1/4" TRS phone plug (mono, balanced)



1	Signal (in phase, +)
2	Signal (out of phase, -)
3	Ground

XLR plug (balanced)

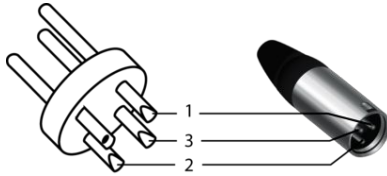

1	Ground, shielding
2	Signal (in phase, +)
3	Signal (out of phase, -)

Mini XLR



1	Ground
2	Positive signal (+)
3	Negative signal (-)

9 Troubleshooting

In the following we list a few common problems that may occur during operation. We give you some suggestions for easy troubleshooting:

Symptom	Remedy
No sound	1. Check the power supply of the transmitter and receiver.
	2. Make sure that both transmitter and receiver operate in the same frequency range. The frequency range is stated on the devices.
	3. Are both transmitter and receiver set to the same channel?
	4. Check the connection between the receiver and the connected audio device (amp, mixer). Is the connected audio device switched on and does the signal level on the output of the receiver match the input sensitivity of the audio device?
	5. Try to improve the transmission by moving the transmitter closer to the receiver.
	6. Make sure that no metal objects near the transmitter or receiver obstruct the transmission.
Transmission is disturbed	1. Modify the orientation of the antennas.
	2. If you use more than one wireless system at the same time, check the used frequencies and channels.
	3. Interference can also be caused by other radio or in-ear systems.

If the procedures recommended above do not succeed, please contact our Service Center. You can find the contact information at www.thomann.de.

10 Protecting the environment

Disposal of the packaging material



For the transport and protective packaging, environmentally friendly materials have been chosen that can be supplied to normal recycling.

Ensure that plastic bags, packaging, etc. are properly disposed of.

Do not just dispose these materials with your normal household waste, but make sure that they are fed to a recovery. Please follow the notes and markings on the packaging.

Disposal of batteries



Batteries must not be disposed of as domestic waste or thrown into fire. Dispose of the batteries according to national or local regulations regarding hazardous waste. To protect the environment, dispose of empty batteries at your retail store or at appropriate collection sites.

Disposal of your old device



This product is subject to the European Waste Electrical and Electronic Equipment Directive (WEEE). Do not dispose with your normal household waste.

Dispose this device through an approved waste disposal firm or through your local waste facility. When discarding the device, comply with the rules and regulations that apply in your country. If in doubt, consult your local waste disposal facility.



