

CLB5 Compact LED Bar
RGBW / RGBWW
LED lighting set

Musikhaus Thomann
Thomann GmbH
Hans-Thomann-Straße 1
96138 Burgebrach
Germany
Telephone: +49 (0) 9546 9223-0
E-mail: info@thomann.de
Internet: www.thomann.de

29.06.2018, ID: 419593, 419587 (V2)

Table of contents

1	General notes	5
	1.1 Further information.....	6
	1.2 Notational conventions.....	7
	1.3 Symbols and signal words.....	8
2	Safety instructions	10
3	Features	16
4	Installation	18
5	Starting up	23
6	Connections and controls	26
7	Operating	34
	7.1 Starting the device.....	34
	7.2 Main menu.....	34
	7.3 Menu overview.....	44
	7.4 Functions in 4-channel DMX mode.....	45
	7.5 Functions in 8-channel DMX mode.....	45

7.6	Functions in 16-channel DMX mode.....	46
7.7	Functions in 18-channel DMX mode.....	48
7.8	Functions in 20-channel DMX mode.....	50
7.9	Reset to factory defaults.....	56
8	Technical specifications.....	57
9	Plug and connection assignments.....	59
10	Cleaning.....	60
11	Protecting the environment.....	61

1 General notes

This manual contains important instructions for the safe operation of the unit. Read and follow the safety instructions and all other instructions. Keep the manual for future reference. Make sure that it is available to all those using the device. If you sell the unit please make sure that the buyer also receives this manual.

Our products are subject to a process of continuous development. Thus, they are subject to change.

1.1 Further information

On our website (www.thomann.de) you will find lots of further information and details on the following points:

Download	This manual is also available as PDF file for you to download.
Keyword search	Use the search function in the electronic version to find the topics of interest for you quickly.
Online guides	Our online guides provide detailed information on technical basics and terms.
Personal consultation	For personal consultation please contact our technical hotline.
Service	If you have any problems with the device the customer service will gladly assist you.

1.2 Notational conventions

This manual uses the following notational conventions:

Letterings

The letterings for connectors and controls are marked by square brackets and italics.

Examples: *[VOLUME]* control, *[Mono]* button.

Displays

Texts and values displayed on the device are marked by quotation marks and italics.

Examples: *'24ch'*, *'OFF'*.

Instructions



The individual steps of an instruction are numbered consecutively. The result of a step is indented and highlighted by an arrow.

Example:

1. ▶ Switch on the device.
2. ▶ Press *[Auto]*.
 - ⇒ Automatic operation is started.
3. ▶ Switch off the device.

1.3 Symbols and signal words

In this section you will find an overview of the meaning of symbols and signal words that are used in this manual.

Signal word	Meaning
DANGER!	This combination of symbol and signal word indicates an immediate dangerous situation that will result in death or serious injury if it is not avoided.
WARNING!	This combination of symbol and signal word indicates a possible dangerous situation that can result in death or serious injury if it is not avoided.
NOTICE!	This combination of symbol and signal word indicates a possible dangerous situation that can result in material and environmental damage if it is not avoided.
Warning signs	Type of danger
	Warning – high-voltage.
	Warning – danger zone.

2 Safety instructions

Intended use

This device is intended for use as an electronic lighting effect by means of LED technology. The device is designed for professional use and is not suitable for use in households. Use the device only as described in this user manual. Any other use or use under other operating conditions is considered to be improper and may result in personal injury or property damage. No liability will be assumed for damages resulting from improper use.

This device may be used only by persons with sufficient physical, sensorial, and intellectual abilities and having corresponding knowledge and experience. Other persons may use this device only if they are supervised or instructed by a person who is responsible for their safety.

Extend the life of the device by regular breaks in operation and avoid switching it on and off frequently. This device is not suitable for continuous use.

Safety**DANGER!****Danger for children**

Ensure that plastic bags, packaging, etc. are disposed of properly and are not within reach of babies and young children. Choking hazard!

Ensure that children do not detach any small parts (e.g. knobs or the like) from the unit. They could swallow the pieces and choke!

Never let children unattended use electrical devices.

**DANGER!****Electric shock caused by high voltages inside**

Within the device there are areas where high voltages may be present. Never remove any covers.

There are no user-serviceable parts inside.

Do not use the device if covers, protectors or optical components are missing or damaged.



DANGER!

Electric shock caused by short-circuit

Always use proper ready-made insulated mains cabling (power cord) with a protective contact plug. Do not modify the mains cable or the plug. Failure to do so could result in electric shock/death or fire. If in doubt, seek advice from a registered electrician.



WARNING!

Eye damage caused by high light intensity

Never look directly into the light source.



WARNING!

Risk of epileptic shock

Strobe lighting can trigger seizures in photosensitive epilepsy. Sensitive persons should avoid looking at strobe lights.



NOTICE!

Risk of fire

Do not block areas of ventilation. Do not install the device near any direct heat source. Keep the device away from naked flames.



NOTICE!

Operating conditions

This device has been designed for indoor use only. To prevent damage, never expose the device to any liquid or moisture. Avoid direct sunlight, heavy dirt, and strong vibrations.

Only operate the device within the ambient conditions specified in the chapter 'Technical specifications' of this user manual. Avoid heavy temperature fluctuations and do not switch the device on immediately after it was exposed to temperature fluctuations (for example after transport at low outside temperatures).

Dust and dirt inside can damage the unit. When operated in harmful ambient conditions (dust, smoke, nicotine, fog, etc.), the unit should be maintained by qualified service personnel at regular intervals to prevent overheating and other malfunction.



NOTICE!

Power supply

Before connecting the device, ensure that the input voltage (AC outlet) matches the voltage rating of the device and that the AC outlet is protected by a residual current circuit breaker. Failure to do so could result in damage to the device and possibly injure the user.

Unplug the device before electrical storms occur and when it is unused for long periods of time to reduce the risk of electric shock or fire.

3 Features

The LED light set offers an ideal combination of white and coloured light for parallel illumination of stage and dance floor in various shades.

- four LED spots with each seven 4-in-1 LEDs, 4 W each, pre-mounted on T-bar
 - Stairville CLB5 RGBW Compact LED Bar 5 (item no. 419593): Red, green, blue, cold white
 - Stairville CLB5 RGB WW Compact LED Bar 5 (item no. 419587): Red, green, blue, warm white
- Control via DMX (five different modes), via buttons and display on the unit, foot switch as well as infrared remote control
- Preprogrammed automatic shows
- Sound control
- Master / Slave mode
- Noiseless operation due to convection cooling
- Sturdy transport bag and infrared remote control included
- Optionally available accessories: Tripod, wireless foot switch unit

For technological reasons, the light output of LEDs decreases over their lifetime. This effect increases with higher operating temperature. You can extend the service life of the illuminants by providing adequate ventilation and operating the LEDs with the lowest possible brightness.

4 Installation

Unpack and carefully check that there is no transportation damage before using the unit. Keep the equipment packaging. To fully protect the device against vibration, dust and moisture during transportation or storage use the original packaging or your own packaging material suitable for transport or storage, respectively.



NOTICE!

Risk of overheating

The distance between light output and the illuminated surface must be more than 1.5 m (19.7in).

Provide sufficient ventilation.

The ambient temperature must always be below 40 °C (104 °F).



NOTICE!

Use of stands

When mounting the device onto a stand, ensure that the stand is in a safe and stable position and that the weight of the device does not exceed the maximum permissible load capacity of the stand.



NOTICE!

Possible data transmission errors

For error-free operation make use of dedicated DMX cables and do not use ordinary microphone cables.

Never connect the DMX input or output to audio devices such as mixers or amplifiers.



Please note that this device must not be connected to a dimmer.

Pre-mounted spots

The four spots are pre-mounted on the T-bar.

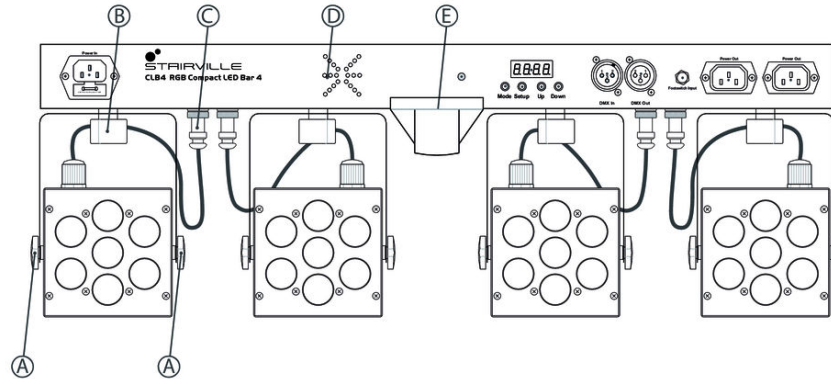

A	Locking screw for fixing the inclination angle.
B	Locking screw for fixing the spots on the T-bar and the horizontal orientation (dispersion direction).
C	Electrical connection of the spot at the T-bar (pre-mounted).

D	1/4" phone socket to connect a foot controller.
E	Flange 36 mm to attach the T-bar on a tripod.

Inserting the battery into the remote control

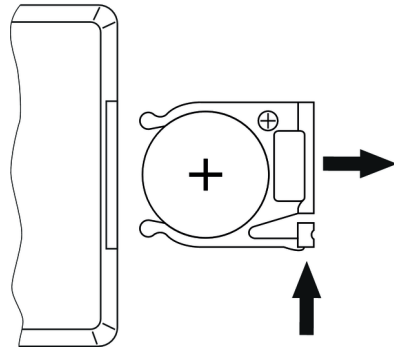

Press the lock of the battery holder to the centre of the housing and pull out the battery holder like a drawer. Insert the battery. The battery is correct if the positive pole points to the housing base of the remote control. Slide the battery holder back into the remote until it clicks into place.

When shipping, the battery is already installed in the remote and protected against discharge by a transparent plastic foil. Remove the plastic foil prior to first use.

5 Starting up

Create all connections while the device is off. Use the shortest possible high-quality cables for all connections. Take care when running the cables to prevent tripping hazards.

Connections in DMX mode

Connect the DMX input of the device to the DMX output of a DMX controller or another DMX device. Connect the output of the first DMX device to the input of the second one, and so on to form a daisy chain. Always ensure that the output of the last DMX device in the daisy chain is terminated with a resistor ($110\ \Omega$, $\frac{1}{4}\ \text{W}$).

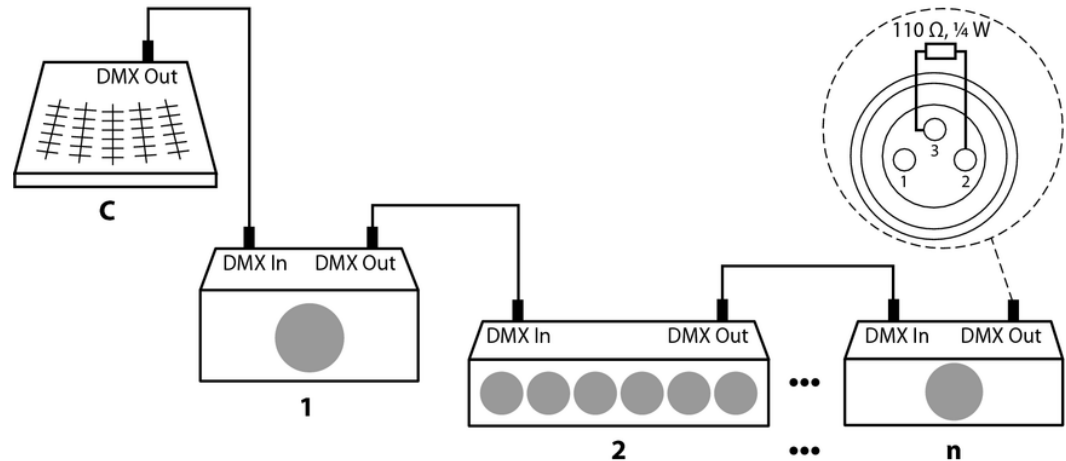

Connections in master/slave mode

When you configure a group of devices in master/slave mode, the first unit will control the other units for an automatic, sound-activated, synchronized show. This function is ideal when you want to start a show immediately. Connect the DMX output of the master device to the DMX input of the first slave device. Then connect the DMX output of the first slave device to the DMX input of the second slave device and so on.

6 Connections and controls

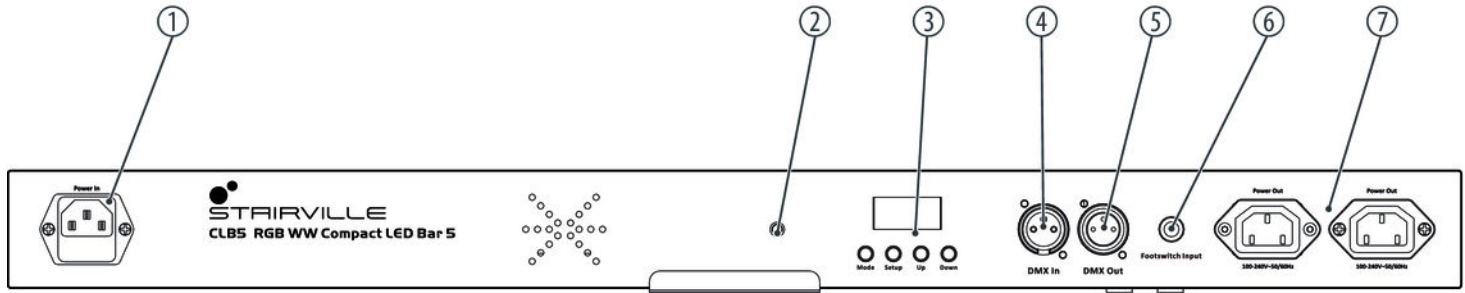

- | | |
|---|---|
| 1 | [Power In]
IEC chassis plug for power supply with fuse holder. |
| 2 | Infrared sensor for the remote control signals. |
| 3 | Display and function buttons. |

	<i>[Mode]</i> Activates the main menu and toggles between menu items. Closes an opened sub menu.
	<i>[Setup]</i> Selects an option of the respective operating mode, confirms the set value.
	<i>[Up]</i> Increases the displayed value by one.
	<i>[Down]</i> Decreases the displayed value by one.
4	<i>[DMX In]</i> DMX input.
5	<i>[DMX Out]</i> DMX output

- | | |
|---|--|
| 6 | <i>[Foot switch Input]</i>
1/4" phone socket to connect a foot controller. |
| 7 | <i>[Power Out]</i>
IEC chassis sockets for the power supply of further devices. |

Foot switch unit (optionally available)

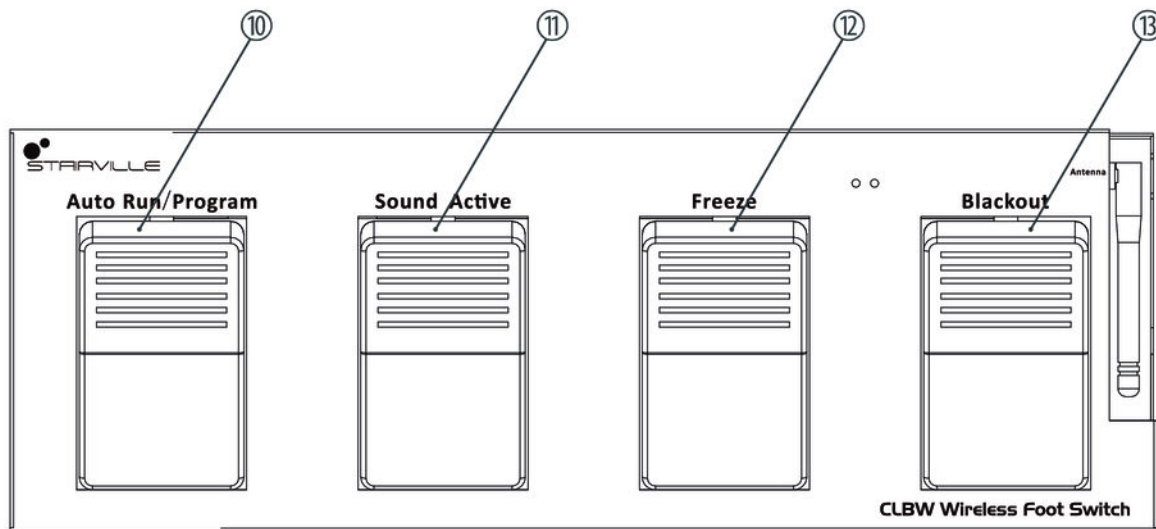

10	<i>[Auto run / programme]</i> Activates the automatic mode (playback of preprogrammed automatic shows).
11	<i>[Sound Active]</i> Activates the sound-controlled mode (playback of sound-controlled automatic shows).
12	<i>[Freeze]</i> Pauses the running show and resumes it after a break.
13	<i>[Blackout]</i> Blackouts all LEDs and turns them back on again.

Infrared remote control

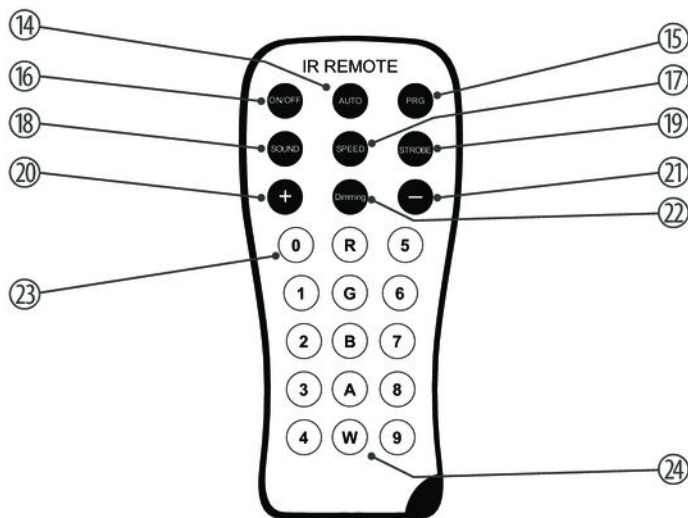

CLB5 Compact LED BarRGBW / RGBWW

14	<i>[AUTO]</i> Activates the Automatic mode.
15	<i>[PRG]</i> Activates the operating mode 'Preprogrammed automatic show'. Select the desired programme with <i>[+]</i> and <i>[-]</i> .
16	<i>[ON/OFF]</i> Activates / deactivates the device.
17	<i>[SPEED]</i> Activates the setting mode for the programme speed. Adjust the speed using <i>[+]</i> and <i>[-]</i> .
18	<i>[SOUND]</i> Activates the 'Sound-controlled' mode. Set the sensitivity of the built-in microphone with <i>[+]</i> and <i>[-]</i> .
19	<i>[STROBE]</i> Activates the setting mode for the Strobe speed. Adjust the speed using <i>[+]</i> and <i>[-]</i> .
20	<i>[+]</i> Increases the set value.

21	<i>[-]</i> Decreases the set value.
22	<i>[Dimming]</i> Activates the dimming function for basic colours. Set the value for each basic colour using <i>[+]</i> and <i>[-]</i> .
23	<i>[0 ... 9]</i> Numeric buttons for direct selection of a basic colour.
24	<i>[R], [G], [B], [A], [W]</i> Buttons to select the colour shade in dimmer mode.

7 Operating

7.1 Starting the device

Connect the device to the power supply to start operation. After a few seconds, the display indicates that a reset is in progress. The device is then ready for use.

7.2 Main menu

Press *[Mode]* to activate the main menu and select an operating mode. Use *[Setup]* to select further options. Use *[Up]* and *[Down]* to change the respectively indicated value. When the display shows the desired value press *[Mode]*.

If you do not press any key for about 30 seconds, the display will be blanked. It will be reactivated to display the previously shown menu by pressing any button.

The set values are retained even when the device is disconnected from the mains power supply.

Operating mode 'Automatic'

Automatic operation can only be activated when the unit is operating in stand alone mode or as master in a master / slave combination. This setting is only relevant if the device is not controlled via DMX.

Press *[Mode]* repeatedly until the display shows 'AUTO'.

Operating mode 'Preprogrammed automatic show'

A preprogrammed automatic show can only be activated when the unit is operating in stand-alone mode or as master in a master / slave combination. This setting is only relevant if the device is not controlled via DMX.

Press *[Mode]* repeatedly until the display shows 'Pro'. Press *[Setup]*. Now you can select one of the preprogrammed automatic shows. Use *[Up]* and *[Down]* to select a value between 'Pr.01' and 'Pr.38'.

Settings for programme 01:

For 'Pr.01', you can choose from 16 basic colours, maximum intensity or blackout of all LEDs. Press *[Setup]*. With *[Up]* and *[Down]* you can now select one of the following options Blackout, Red, Green, Blue, White, Amber, Orange, Yellow, Magenta, Pink, Cyan, Light red, Light green, Light blue, Warm white, Cold white.

To adjust the strobe frequency, press *[Setup]*. With *[Up]* and *[Down]* you can now select a value between 'FL00' (slow) and 'FL99' (fast).

Settings for programmes 02 ... 28:

To adjust the speed of the selected automatic show, press *[Setup]* repeatedly until the display shows 'SPxx'. With *[Up]* and *[Down]* you can now select a value between 'SP.01' (slow) and 'SP.99' (fast).

To adjust the strobe frequency, press *[Setup]* repeatedly until the display shows 'FL.xx'. With *[Up]* and *[Down]* you can now select a value between 'FL.00' (slow) and 'FL.99' (fast).

Operating mode 'Slave'

This setting is only relevant if the device is serving as Slave in a Master / Slave configuration and is not controlled via DMX.

Press *[Mode]* repeatedly until the display shows 'SLAV' and confirm with *[Setup]*.

DMX mode

This setting is only relevant when the device is controlled via DMX.

Press *[Mode]* repeatedly until the display shows 'd.xxx'. Press *[Setup]*.

Now you can set the number of the first DMX channel to be used by the device (DMX address). Use *[Up]* and *[Down]* to select a value between 1 and 512 (the display shows 'd.001' ... 'd.510').

Make sure that this number matches the configuration of your DMX controller. The following table shows the highest possible DMX address for the various DMX modes.

Mode	Highest possible DMX address
4-channel	509
8-channel	505
16-channel	497
18-channel	495
20-channel	493

Press *[Setup]*. With *[Up]* and *[Down]* you can now select one of the following DMX operating modes:

- '4-ch' (four channels)
- '8-ch' (eight channels)
- '16ch' (sixteen channels)
- '18ch' (eighteen channels)
- '20ch' (twenty channels)

Sound control

A sound-controlled show can only be activated when the unit is operating in stand alone mode or as master in a master / slave combination. This setting is only relevant if the device is not controlled via DMX.

Press *[Mode]* repeatedly until the display shows 'Soud'. Press *[Setup]*. Press *[Up]* and *[Down]* to activate one of the available sound modes 'SO.00' ... 'SO.37'.

Press *[Setup]*. Now you can adjust the sensitivity for the sound control. Use *[Up]* and *[Down]* to select a value between 0 (low sensitivity) and 31 (high sensitivity), the display shows 'SU.00' ... 'SU.31'.

Constant unicoloured pattern

A constant unicoloured pattern can only be activated when the unit is operating in stand alone mode or as master in a master / slave combination. This setting is only relevant if the device is not controlled via DMX.

Press *[Mode]* repeatedly until the display shows 'Colr'. Press *[Setup]*.

With *[Up]* and *[Down]* you can choose from the following options:

Display	Meaning
'r.000' ... 'r.255'	Red
'g.000' ... 'g.255'	Green
'b.000' ... 'b.255'	Blue
'u.000' ... 'u.255'	White

Dimmer curve

Press *[Mode]* repeatedly until the display shows 'Set'. Press *[Setup]*. Use *[Up]* | *[Down]* to select the menu item 'Cu.SE' and confirm with *[Setup]*.

With *[Up]* | *[Down]* you can select one of the following dimmer curves. The dimmer curve determines how the brightness increases or decreases depending on the set DMX value.

Display	Meaning
'Cu-1'	Linear (proportional) course
'Cu-2'	Quadratic curve with a flat profile at the beginning and a steep profile at the end (Square)
'Cu-3'	Inverted quadratic curve with a steep profile at the beginning and a flat profile at the end (Inv Square)
'Cu-4'	Non-linear curve with a distinctive flat profile at the beginning and the end (S-Type)

The below figure schematically shows the adjustable dimmer curves. Depending on the selected DMX value (1) the device lights with a brightness (2) between 0 % and 100 %. Confirm the selection with *[Setup]*. Press *[Mode]*.

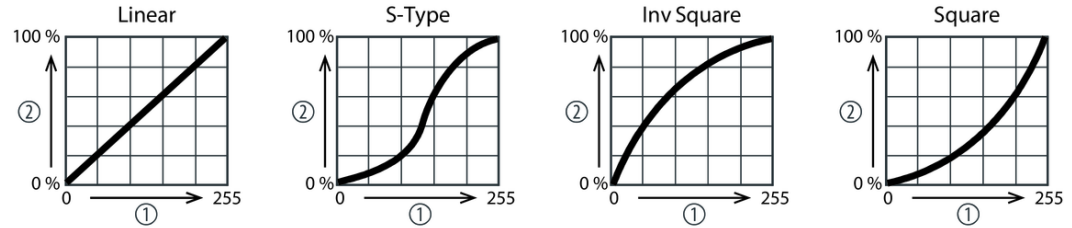

Dimmer speed

Press *[Mode]* repeatedly until the display shows 'Set'. Press *[Setup]*. Use *[Up]* | *[Down]* to select the menu item 'di.SP' and confirm with *[Setup]*.

With *[Up]* and *[Down]* you can choose the response speed of the dimmer between 'FAST' (fast) and 'SLOW' (slow). Confirm the selection with *[Setup]*. Press *[Mode]*.

Reset

Press *[Mode]* repeatedly until the display shows 'Set'. *[Setup]*. Use *[Up]* | *[Down]* to select the menu item '-rSt' and confirm with *[Setup]*. Use *[Up]* | *[Down]* choose between 'YES' (carry out reset) and 'NO' (no reset) and confirm with *[Setup]*.

Behaviour on DMX failure

Press *[Mode]* repeatedly until the display shows 'Set'. *[Setup]*. Use *[Up]* | *[Down]* to select the menu item 'FAIL' and confirm with *[Setup]*. With *[Up]* | *[Down]* you can choose how the device behaves in case of a disturbed DMX transmission: 'HoLd' (the current state is retained) and 'OFF' (device blackout). Confirm the selection with *[Setup]*.

DMX synchronisation

Press *[Mode]* repeatedly until the display shows 'Set'. *[Setup]*. Use *[Up]* | *[Down]* to select the menu item 'Sync' and confirm with *[Setup]*. With *[Up]* | *[Down]* you can choose how connected devices behaves in case of a disturbed DMX transmission: 'On' (devices are synchronised with each other) and 'Off' (no synchronisation). Confirm the selection with *[Setup]*.

Enabling a wireless foot switch

Press *[Mode]* repeatedly until the display shows 'Set'. *[Setup]*. Use *[Up]* | *[Down]* to select the menu item 'Hey' and confirm with *[Setup]*. With *[Up]* | *[Down]* you can enable ('On') or disable ('Off') a wireless foot switch. Confirm the selection with *[Setup]*.

Firmware version

Press *[Mode]* repeatedly until the display shows 'InFo'. Press *[Setup]*, the display shows 'Ver'. Press *[Setup]* to let the device show the Firmware version.

7.3 Menu overview

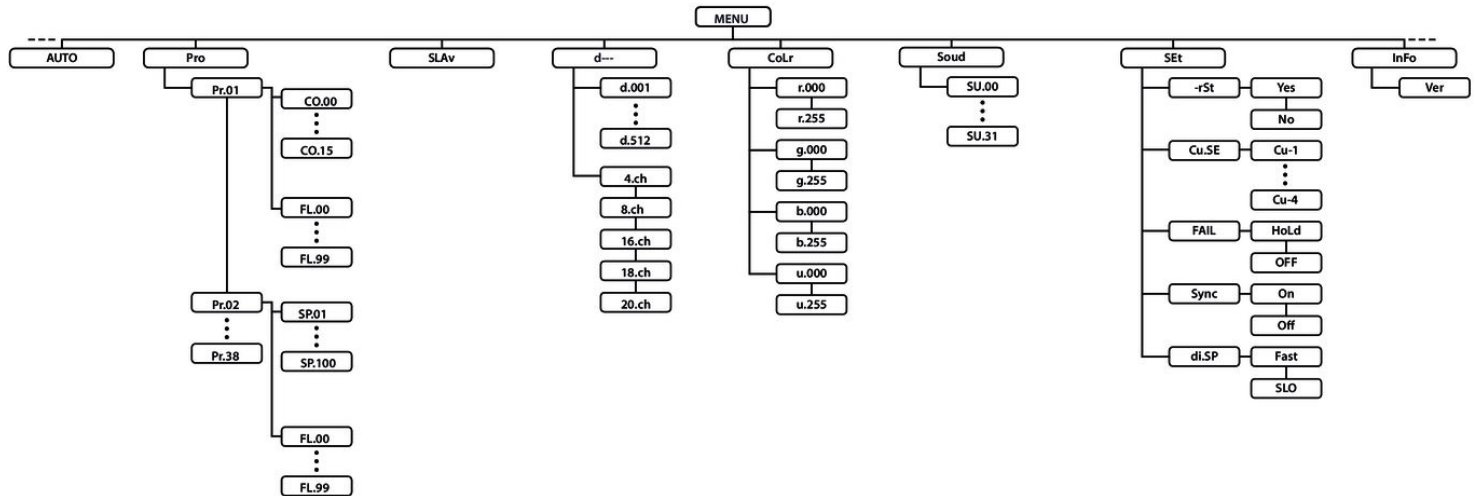

7.4 Functions in 4-channel DMX mode

Channel	Value	Function
1	0...255	Intensity red (0 % to 100 %), for all LEDs together
2	0...255	Intensity green (0 % to 100 %), for all LEDs together
3	0...255	Intensity blue (0 % to 100 %), for all LEDs together
4	0...255	Intensity white (0 % to 100 %), for all LEDs

7.5 Functions in 8-channel DMX mode

Channel	Value	Function
1	0...255	Intensity red (0 % to 100 %) for all LEDs spot 1 and 2
2	0...255	Intensity green (0 % to 100 %) for all LEDs spot 1 and 2
3	0...255	Intensity blue (0 % to 100 %) for all LEDs spot 1 and 2

Channel	Value	Function
4	0...255	Intensity white (0 % to 100 %) for all LEDs spot 1 and 2
5	0...255	Intensity red (0 % to 100 %) for all LEDs spot 3 and 4
6	0...255	Intensity green (0 % to 100 %) for all LEDs spot 3 and 4
7	0...255	Intensity blue (0 % to 100 %) for all LEDs spot 3 and 4
8	0...255	Intensity white (0 % to 100 %) for all LEDs spot 3 and 4

7.6 Functions in 16-channel DMX mode

Channel	Value	Function
1	0...255	Intensity red (0 % to 100 %) for all LEDs spot 1
2	0...255	Intensity green (0 % to 100 %) for all LEDs spot 1
3	0...255	Intensity blue (0 % to 100 %) for all LEDs spot 1

Channel	Value	Function
4	0...255	Intensity white (0 % to 100 %) for all LEDs spot 1
5	0...255	Intensity red (0 % to 100 %) for all LEDs spot 2
6	0...255	Intensity green (0 % to 100 %) for all LEDs spot 2
7	0...255	Intensity blue (0 % to 100 %) for all LEDs spot 2
8	0...255	Intensity white (0 % to 100 %) for all LEDs spot 2
9	0...255	Intensity red (0 % to 100 %) for all LEDs spot 3
10	0...255	Intensity green (0 % to 100 %) for all LEDs spot 3
11	0...255	Intensity blue (0 % to 100 %) for all LEDs spot 3
12	0...255	Intensity white (0 % to 100 %) for all LEDs spot 3
13	0...255	Intensity red (0 % to 100 %) for all LEDs spot 4
14	0...255	Intensity green (0 % to 100 %) for all LEDs spot 4
15	0...255	Intensity blue (0 % to 100 %) for all LEDs spot 4
16	0...255	Intensity white (0 % to 100 %) for all LEDs spot 4

7.7 Functions in 18-channel DMX mode

Channel	Value	Function
1	0...255	Dimmer (0 % bis 100 %)
2	0...255	Intensity red (0 % to 100 %) for all LEDs spot 1
3	0...255	Intensity green (0 % to 100 %) for all LEDs spot 1
4	0...255	Intensity blue (0 % to 100 %) for all LEDs spot 1
5	0...255	Intensity white (0 % to 100 %) for all LEDs spot 1
6	0...255	Intensity red (0 % to 100 %) for all LEDs spot 2
7	0...255	Intensity green (0 % to 100 %) for all LEDs spot 2
8	0...255	Intensity blue (0 % to 100 %) for all LEDs spot 2
9	0...255	Intensity white (0 % to 100 %) for all LEDs spot 2
10	0...255	Intensity red (0 % to 100 %) for all LEDs spot 3
11	0...255	Intensity green (0 % to 100 %) for all LEDs spot 3

Channel	Value	Function
12	0...255	Intensity blue (0 % to 100 %) for all LEDs spot 3
13	0...255	Intensity white (0 % to 100 %) for all LEDs spot 3
14	0...255	Intensity red (0 % to 100 %) for all LEDs spot 4
15	0...255	Intensity green (0 % to 100 %) for all LEDs spot 4
16	0...255	Intensity blue (0 % to 100 %) for all LEDs spot 4
17	0...255	Intensity white (0 % to 100 %) for all LEDs spot 4
18	Strobe effect	
	0...4	No function
	5...255	Stroboscope effect (0 % to 100 %)

7.8 Functions in 20-channel DMX mode

Channel	Value	Function
1	0...255	Dimmer (0 % bis 100 %)
2	0...255	Intensity red (0 % to 100 %) for all LEDs spot 1
3	0...255	Intensity green (0 % to 100 %) for all LEDs spot 1
4	0...255	Intensity blue (0 % to 100 %) for all LEDs spot 1
5	0...255	Intensity white (0 % to 100 %) for all LEDs spot 1
6	0...255	Intensity red (0 % to 100 %) for all LEDs spot 2
7	0...255	Intensity green (0 % to 100 %) for all LEDs spot 2
8	0...255	Intensity blue (0 % to 100 %) for all LEDs spot 2
9	0...255	Intensity white (0 % to 100 %) for all LEDs spot 2
10	0...255	Intensity red (0 % to 100 %) for all LEDs spot 3
11	0...255	Intensity green (0 % to 100 %) for all LEDs spot 3

Channel	Value	Function
12	0...255	Intensity blue (0 % to 100 %) for all LEDs spot 3
13	0...255	Intensity white (0 % to 100 %) for all LEDs spot 3
14	0...255	Intensity red (0 % to 100 %) for all LEDs spot 4
15	0...255	Intensity green (0 % to 100 %) for all LEDs spot 4
16	0...255	Intensity blue (0 % to 100 %) for all LEDs spot 4
17	0...255	Intensity white (0 % to 100 %) for all LEDs spot 4
18	0	Dimmer
	1...5	Preprogrammed automatic show 01
	11...16	Preprogrammed automatic show 02
	12...17	Preprogrammed automatic show 03
	18...23	Preprogrammed automatic show 04
	24...29	Preprogrammed automatic show 05
	30...35	Preprogrammed automatic show 06

Channel	Value	Function
	36...41	Preprogrammed automatic show 07
	42...47	Preprogrammed automatic show 08
	48...53	Preprogrammed automatic show 09
	54...59	Preprogrammed automatic show 10
	60...65	Preprogrammed automatic show 11
	66...71	Preprogrammed automatic show 12
	72...77	Preprogrammed automatic show 13
	78...83	Preprogrammed automatic show 14 ('Carnival in Rio')
	84...89	Preprogrammed automatic show 15
	90...95	Preprogrammed automatic show 16
	96...101	Preprogrammed automatic show 17
	102...107	Preprogrammed automatic show 18
	108...113	Preprogrammed automatic show 19

Channel	Value	Function
	114...119	Preprogrammed automatic show 20
	120...125	Preprogrammed automatic show 21
	126...131	Preprogrammed automatic show 22
	132...137	Preprogrammed automatic show 23
	138...143	Preprogrammed automatic show 24
	144...149	Preprogrammed automatic show 25
	150...155	Preprogrammed automatic show 26
	156...161	Preprogrammed automatic show 27
	162...167	Preprogrammed automatic show 28
	168...173	Preprogrammed automatic show 29
	174...179	Preprogrammed automatic show 30
	180...185	Preprogrammed automatic show 31 ('Blue & Orange')
	186...191	Preprogrammed automatic show 32 ('Campfire')

Channel	Value	Function
	192...197	Preprogrammed automatic show 33 ('Ice Time')
	198...203	Preprogrammed automatic show 34 ('Old School')
	204...209	Preprogrammed automatic show 35 ('Pink Panther')
	210...215	Preprogrammed automatic show 36 ('Rainbow')
	216...221	Preprogrammed automatic show 37 ('Reggae')
	222...227	Preprogrammed automatic show 38 ('Techno Time')
	228...255	Sound-controlled show
19	Function depending on setting of channel 18	
	Channel 18 = 0...5	
	0...15	R: 0; G: 0; B: 0; W: 0;
	16...31	R: 255; G: 0; B: 0; W: 0;
	32...47	R: 0; G: 255; B: 0; W: 0;
	48...63	R: 0; G: 0; B: 255; W: 0;

Channel	Value	Function
	64...79	R: 0; G: 0; B: 0; W: 255;
	80...95	R: 255; G: 150; B: 0; W: 0;
	96...111	R: 255; G: 180; B: 0; W: 0;
	112...127	R: 255; G: 255; B: 0; W: 0;
	128...143	R: 255; G: 0; B: 255; W: 0;
	144...159	R: 255; G: 0; B: 140; W: 0;
	160...175	R: 0; G: 255; B: 255; W: 0;
	176...191	R: 255; G: 0; B: 0; W: 210;
	192...207	R: 0; G: 255; B: 0; W: 210;
	208...223	R: 0; G: 0; B: 255; W: 210;
	224...239	R: 255; G: 200; B: 40; W: 90;
	240...255	R: 255; G: 255; B: 255; W: 255;
	Channel 18 = 6...227	

Channel	Value	Function
	0...255	Programme speed Pr.02...Pr.38
	Channel 18 = 228...255	
	0...255	Sound-controlled operation SO.01...SO.37
20	Strobe effect	
	0...4	No function
	5...255	Stroboscope effect (0 % to 100 %)

7.9 Reset to factory defaults

Proceed as follows to reset the device to factory defaults:

1. ➤ Switch off the device.
2. ➤ Switch the device back on and keep *[Mode]* and *[Setup]* pressed for about 2 seconds.

8 Technical specifications

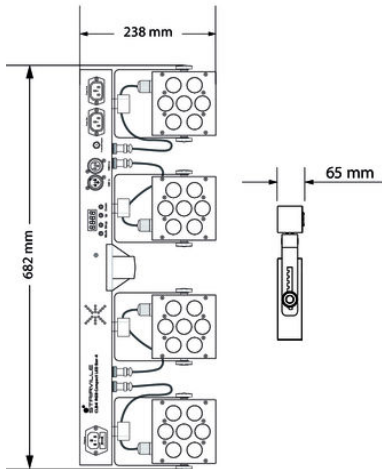

	CLB5 RGBW Compact LED Bar 5	CLB5 RGB WW Compact LED Bar 5
Item no.	419593	419587
Illuminant	28 × RGBW-LEDs, each 4 W	28 × RGBWW-LEDs, each 4 W
Number of DMX channels	4, 8, 16, 18, or 20 channels, depending on operating mode	
Beam angle	ca. 40°	
Operating supply voltage	AC 100 – 240 V ~ 50/60 Hz	
Power consumption	110 W	
Fuse	5 mm × 20 mm, 2 A, 250 V, slow blow	
Battery for the remote control	1 × CR 2025 (Lithium, 3 V)	

CLB5 Compact LED Bar RGBW / RGBWW

	CLB5 RGBW Compact LED Bar 5	CLB5 RGB WW Compact LED Bar 5
Dimensions (W × H × D)	682 mm × 238 mm × 65 mm	
Weight	5.5 kg	

Environmental conditions

Temperature range	0 °C...40 °C
Relative humidity	50 %, non-condensing

9 Plug and connection assignments

Introduction

This chapter will help you select the right cables and plugs to connect your valuable equipment so that a perfect light experience is guaranteed.

Please take our tips, because especially in 'Sound & Light' caution is indicated: Even if a plug fits into a socket, the result of an incorrect connection may be a destroyed DMX controller, a short circuit or 'just' a not working light show!

DMX connections



The unit offers a 3-pin XLR socket for DMX output and a 3-pin XLR plug for DMX input. Please refer to the drawing and table below for the pin assignment of a suitable XLR plug.

Pin	Configuration
1	Ground, shielding
2	Signal inverted (DMX-, 'cold signal')
3	Signal (DMX+, 'hot signal')

10 Cleaning

Optical lenses

Clean the optical lenses, that are accessible from the outside, regularly in order to optimize the light output. The frequency of cleaning depends on the operating environment: wet, smoky or particularly dirty surroundings can cause more accumulation of dirt on the optics of the device.

- Clean with a soft cloth using our lamp and lens cleaner (item no. 280122).
- Always dry the parts carefully.

Fan grids

The fan grids of the device must be cleaned on a regular basis to remove dust and dirt. Before cleaning, switch off the device and disconnect AC-powered devices from the mains. Use a lint-free damp cloth for cleaning. Never use solvents or alcohol for cleaning.

11 Protecting the environment

Disposal of the packaging material



For the transport and protective packaging, environmentally friendly materials have been chosen that can be supplied to normal recycling.

Ensure that plastic bags, packaging, etc. are properly disposed of.

Do not just dispose of these materials with your normal household waste, but make sure that they are fed to a recovery. Please follow the notes and markings on the packaging.

Disposal of batteries



Batteries must not be disposed of as domestic waste or thrown into fire. Dispose of the batteries according to national or local regulations regarding hazardous waste. To protect the environment, dispose of empty batteries at your retail store or at appropriate collection sites.

Disposal of your old device



This product is subject to the European Waste Electrical and Electronic Equipment Directive (WEEE) in its currently valid version. Do not dispose with your normal household waste.

Dispose this device through an approved waste disposal firm or through your local waste facility. When discarding the device, comply with the rules and regulations that apply in your country. If in doubt, consult your local waste disposal facility.



