



BEL6 Battery Event Light  
6x15W  
LED spotlight

Musikhaus Thomann  
Thomann GmbH  
Hans-Thomann-Straße 1  
96138 Burgebrach  
Germany  
Telephone: +49 (0) 9546 9223-0  
E-mail: [info@thomann.de](mailto:info@thomann.de)  
Internet: [www.thomann.de](http://www.thomann.de)

24.05.2018, ID: 428090

# Table of contents

<b>1</b>	<b>General notes</b> .....	<b>5</b>
	1.1 Further information.....	6
	1.2 Notational conventions.....	7
	1.3 Symbols and signal words.....	8
<b>2</b>	<b>Safety instructions</b> .....	<b>10</b>
<b>3</b>	<b>Features</b> .....	<b>18</b>
<b>4</b>	<b>Installation</b> .....	<b>19</b>
	4.1 Dealing with lithium batteries.....	24
<b>5</b>	<b>Starting up</b> .....	<b>26</b>
<b>6</b>	<b>Connections and controls</b> .....	<b>28</b>
<b>7</b>	<b>Operating</b> .....	<b>36</b>
	7.1 Starting the device.....	36
	7.2 Main menu.....	37
	7.3 Menu overview.....	42
	7.4 Functions in 6-channel DMX mode.....	43

7.5	Functions in 10-channel DMX mode.....	44
<b>8</b>	<b>Technical specifications.....</b>	<b>46</b>
<b>9</b>	<b>Plug and connection assignments.....</b>	<b>48</b>
<b>10</b>	<b>Troubleshooting.....</b>	<b>49</b>
<b>11</b>	<b>Cleaning.....</b>	<b>51</b>
<b>12</b>	<b>Protecting the environment.....</b>	<b>52</b>

# 1 General notes

This manual contains important instructions for the safe operation of the unit. Read and follow the safety instructions and all other instructions. Keep the manual for future reference. Make sure that it is available to all those using the device. If you sell the unit please make sure that the buyer also receives this manual.

Our products are subject to a process of continuous development. Thus, they are subject to change.

## 1.1 Further information

On our website ([www.thomann.de](http://www.thomann.de)) you will find lots of further information and details on the following points:

Download	This manual is also available as PDF file for you to download.
Keyword search	Use the search function in the electronic version to find the topics of interest for you quickly.
Online guides	Our online guides provide detailed information on technical basics and terms.
Personal consultation	For personal consultation please contact our technical hotline.
Service	If you have any problems with the device the customer service will gladly assist you.

## 1.2 Notational conventions

This manual uses the following notational conventions:

### Letterings

The letterings for connectors and controls are marked by square brackets and italics.

**Examples:** *[VOLUME]* control, *[Mono]* button.

### Displays

Texts and values displayed on the device are marked by quotation marks and italics.

**Examples:** *'24ch'*, *'OFF'*.

### Cross-references

References to other locations in this manual are identified by an arrow and the specified page number. In the electronic version of the manual, you can click the cross-reference to jump to the specified location.



Example: See [↪](#) *'Cross-references'* on page 7.

### 1.3 Symbols and signal words

In this section you will find an overview of the meaning of symbols and signal words that are used in this manual.

Signal word	Meaning
<b>DANGER!</b>	This combination of symbol and signal word indicates an immediate dangerous situation that will result in death or serious injury if it is not avoided.
<b>WARNING!</b>	This combination of symbol and signal word indicates a possible dangerous situation that can result in death or serious injury if it is not avoided.
<b>NOTICE!</b>	This combination of symbol and signal word indicates a possible dangerous situation that can result in material and environmental damage if it is not avoided.



Warning signs	Type of danger
 A yellow triangular warning sign with a black border and a black lightning bolt symbol in the center, indicating high voltage.	Warning – high-voltage.
 A yellow triangular warning sign with a black border and a black symbol of a person standing on a suspended platform or load, indicating a suspended load.	Warning – suspended load.
 A yellow triangular warning sign with a black border and a black exclamation mark in the center, indicating a general danger or hazard.	Warning – danger zone.

## 2 Safety instructions

### **Intended use**

This device is intended for use as an electronic lighting effect by means of LED technology. The device is designed for professional use and is not suitable for use in households. Use the device only as described in this user manual. Any other use or use under other operating conditions is considered to be improper and may result in personal injury or property damage. No liability will be assumed for damages resulting from improper use.

This device may be used only by persons with sufficient physical, sensorial, and intellectual abilities and having corresponding knowledge and experience. Other persons may use this device only if they are supervised or instructed by a person who is responsible for their safety.

Extend the life of the device by regular breaks in operation and avoid switching it on and off frequently. This device is not suitable for continuous use.

**Safety****DANGER!****Danger for children**

Ensure that plastic bags, packaging, etc. are disposed of properly and are not within reach of babies and young children. Choking hazard!

Ensure that children do not detach any small parts (e.g. knobs or the like) from the unit. They could swallow the pieces and choke!

Never let children unattended use electrical devices.

**DANGER!****Electric shock caused by high voltages inside**

Within the device there are areas where high voltages may be present. Never remove any covers.

There are no user-serviceable parts inside.

Do not use the device if covers, protectors or optical components are missing or damaged.



**DANGER!**

**Electric shock caused by short-circuit**

Always use proper ready-made insulated mains cabling (power cord) with a protective contact plug. Do not modify the mains cable or the plug. Failure to do so could result in electric shock/death or fire. If in doubt, seek advice from a registered electrician.



**WARNING!**

**Eye damage caused by high light intensity**

Never look directly into the light source.



**WARNING!**

**Risk of epileptic shock**

Strobe lighting can trigger seizures in photosensitive epilepsy. Sensitive persons should avoid looking at strobe lights.



**WARNING!**

**Incorrect handling of lithium batteries can result in injury**

In the event of a short circuit, overheating or mechanical damage, lithium batteries can cause severe injuries.

Follow the advice on the correct handling of lithium batteries in the present section.



**NOTICE!**

**Risk of fire**

Do not block areas of ventilation. Do not install the device near any direct heat source. Keep the device away from naked flames.



### **NOTICE!**

#### **Operating conditions**

This device has been designed for indoor use only. To prevent damage, never expose the device to any liquid or moisture. Avoid direct sunlight, heavy dirt, and strong vibrations.

Only operate the device within the ambient conditions specified in the chapter 'Technical specifications' of this user manual. Avoid heavy temperature fluctuations and do not switch the device on immediately after it was exposed to temperature fluctuations (for example after transport at low outside temperatures).

Dust and dirt inside can damage the unit. When operated in harmful ambient conditions (dust, smoke, nicotine, fog, etc.), the unit should be maintained by qualified service personnel at regular intervals to prevent overheating and other malfunction.



**NOTICE!**

**Power supply**

Before connecting the device, ensure that the input voltage (AC outlet) matches the voltage rating of the device and that the AC outlet is protected by a residual current circuit breaker. Failure to do so could result in damage to the device and possibly injure the user.

Unplug the device before electrical storms occur and when it is unused for long periods of time to reduce the risk of electric shock or fire.



**NOTICE!**

**Risk of fire due to incorrect polarity**

Incorrectly inserted batteries may destroy the device or the batteries.

Ensure that proper polarity is observed when inserting batteries.



### **NOTICE!**

#### **Possible damage by leaking batteries**

Leaking batteries can cause permanent damage to the device.

Take batteries out of the device if it is not going to be used for a longer period.



### **NOTICE!**

#### **Possible staining**

The plasticiser contained in the rubber feet of this product may possibly react with the coating of your parquet, linoleum, laminate or PVC floor and after some time cause permanent dark stains.

In case of doubt, do not put the rubber feet directly on the floor, but use felt-pad floor protectors or a carpet.





**NOTICE!**

**Possible damage due to incorrect storage**

Deep discharge can cause batteries to become permanently damaged or lose some of their capacity.

Before prolonged rest periods, charge the batteries to around 50 % of their capacity and then switch the equipment off. Store the equipment at a temperature between 10 °C and 32 °C in as dry an environment as possible. During extended storage periods, charge the batteries to 50 % approximately every three months.

### 3 Features

Special features of the device:

- Six six-colour LEDs (RGBAWUV, 15 W each)
- Operable in stand-alone mode or DMX
- Control via DMX/Wireless DMX, via the supplied infrared remote control and via the buttons and colour display on the unit
- Numerous pre-programmed mixed colours and effects
- Sound control via built-in microphone
- Various mounting options
- Battery or mains powered
- Matching Touring Case (item no. 428091) optionally available with charger; charger included with the Tourpack (item 429883)

For technological reasons, the light output of LEDs decreases over their lifetime. This effect increases with higher operating temperature. You can extend the service life of the illuminants by providing adequate ventilation and operating the LEDs with the lowest possible brightness.

## 4 Installation

Unpack and carefully check that there is no transportation damage before using the unit. Keep the equipment packaging. To fully protect the device against vibration, dust and moisture during transportation or storage use the original packaging or your own packaging material suitable for transport or storage, respectively.



### **WARNING!**

#### **Risk of injury caused by falling objects**

Make sure that the installation complies with the standards and rules that apply in your country. Always secure the device with a secondary safety attachment, such as a safety cable or a safety chain.



### **NOTICE!**

#### **Risk of overheating**

The distance between light output and the illuminated surface must be more than 1.5 m (19.7in).

Provide sufficient ventilation.

The ambient temperature must always be below 40 °C (104 °F).



### **NOTICE!**

#### **Use of stands**

When mounting the device onto a stand, ensure that the stand is in a safe and stable position and that the weight of the device does not exceed the maximum permissible load capacity of the stand.

**NOTICE!****Possible data transmission errors**

For error-free operation make use of dedicated DMX cables and do not use ordinary microphone cables.

Never connect the DMX input or output to audio devices such as mixers or amplifiers.

**Mounting options**

You can install the device using a stand, as well as standing or hanging upside down. When in use, the device must always be attached to a solid surface or an approved truss. Use the threads provided for mounting.

Always work from a stable platform whenever installing, moving or servicing the unit. In doing so, the area underneath the unit must be cordoned off.

The safety cable must be threaded through the cut-outs in the housing.



*Please note that this device must not be connected to a dimmer.*

### **Infrared sensor for the remote control**

The infrared receiver for the IR remote control signals is located between the LEDs on the front panel of the device. Make sure that it is not obstructed.

### Inserting the battery into the remote control

Press the lock of the battery holder to the centre of the housing and pull out the battery holder like a drawer. Insert the battery. The battery is correct if the positive pole points to the housing base of the remote control. Slide the battery holder back into the remote until it clicks into place.

When shipping, the battery is already installed in the remote and protected against discharge by a transparent plastic foil. Remove the plastic foil prior to first use.

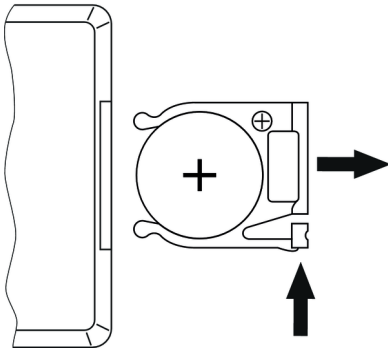

## 4.1 Dealing with lithium batteries



### **WARNING!**

#### **Incorrect handling of lithium batteries can result in injury**

In the event of a short circuit, overheating or mechanical damage, lithium batteries can cause severe injuries.

Follow the advice on the correct handling of lithium batteries in the present section.

When handled correctly and appropriately lithium batteries pose no risk.

Store lithium batteries in a cool, dry place, ideally in the original packaging.

Store lithium batteries away from heat sources (e.g. radiators or sunlight). Lithium batteries are hermetically sealed. Never attempt to open a lithium battery.

If the battery housing is damaged small amounts of the electrolyte may leak out. If this should happen, seal the lithium battery in airtight packaging and wipe up the traces of electrolyte using absorbent paper towels. You must wear protective rubber gloves when doing so. Clean your hands and the affected surface thoroughly with cold water.



Never attempt to recharge non-rechargeable lithium batteries. When charging lithium batteries you must use a suitable charging device intended for the purpose.

Before disposing of the device remove the lithium batteries. Protect used lithium batteries against potential short circuits, e.g. by covering the poles with adhesive tape.

Only use powder extinguishers or other suitable extinguishing agents to extinguish a burning lithium battery.

## 5 Starting up

Create all connections while the device is off. Use the shortest possible high-quality cables for all connections. Take care when running the cables to prevent tripping hazards.

**Connections in DMX mode**

Connect the DMX input of the device to the DMX output of a DMX controller or another DMX device. Connect the output of the first DMX device to the input of the second one, and so on to form a daisy chain. Always ensure that the output of the last DMX device in the daisy chain is terminated with a resistor ( $110\ \Omega$ ,  $\frac{1}{4}\ \text{W}$ ).

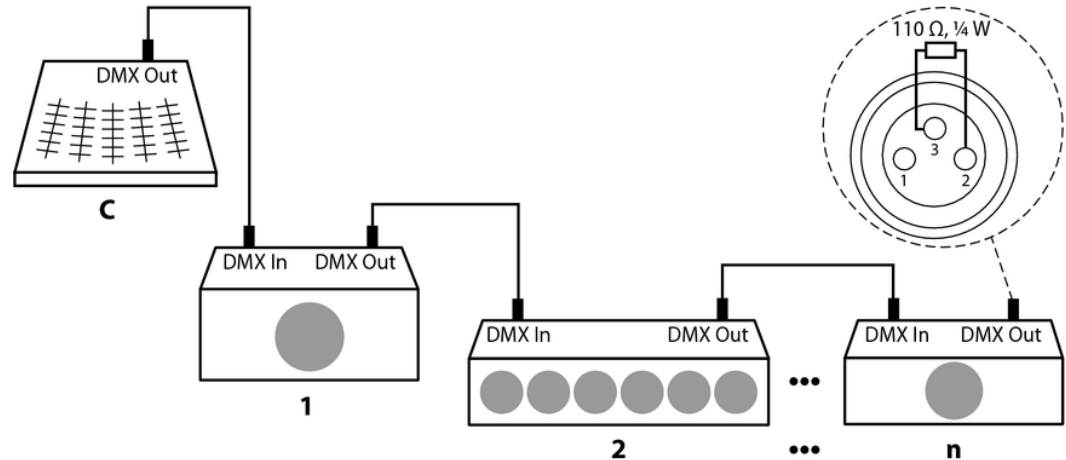

## 6 Connections and controls

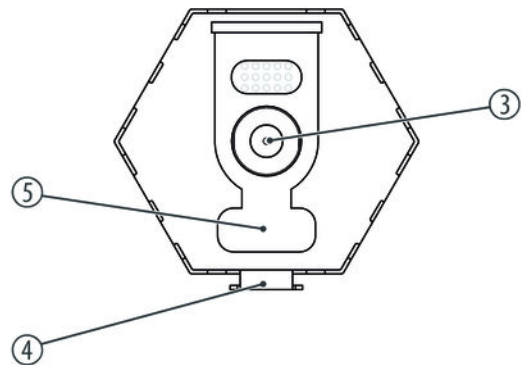
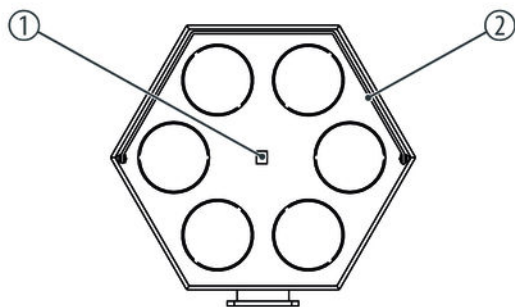

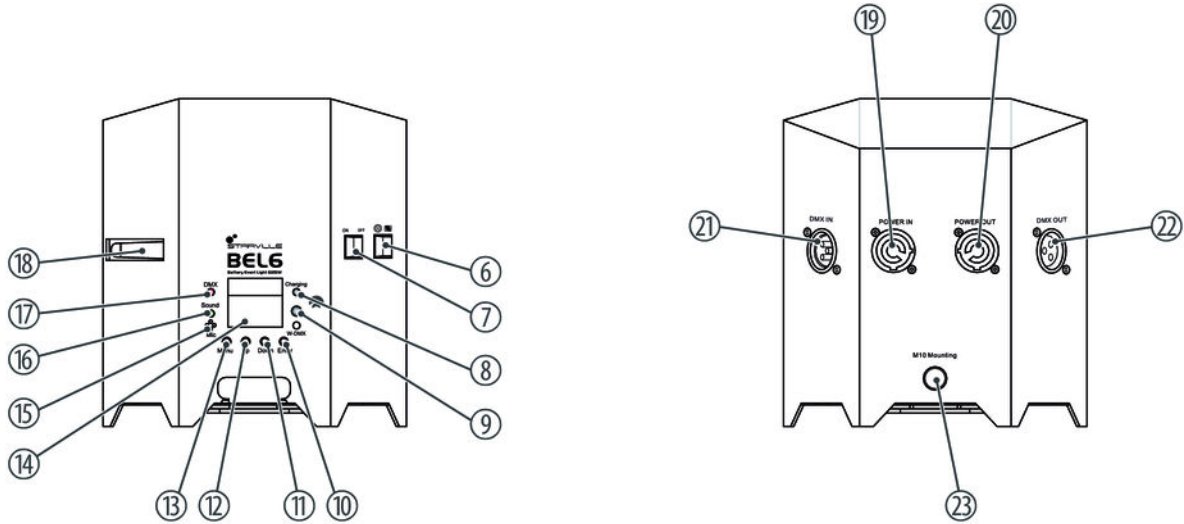

BEL6 Battery Event Light 6x15W

1	Infrared sensor for the remote control signals
2	Folding clamp
3	Charging plug, suitable for the charging socket on the Flight Case
4	Mechanical release for the flap
5	Flap for disconnecting the device from the charging socket on the Flight Case with opening for the safety cable
6	Switch for selecting the voltage source for charging (mains connection or charging contact on the Touring Case)
7	<i>[ON / OFF]</i> Main switch. Turns the device on and off
8	<i>[Charging]</i> If the charge indicator light is red, the internal battery is being charged. If the LED is red and green, the battery is fully charged.
9	<i>[W-DMX]</i> The LED indicates that a Wireless DMX signal is being received.

10	<i>[Enter]</i> Selects an option of the respective operating mode, confirms the set value
11, 12	<i>[Up], [Down]</i> Toggles between the menu items of a menu level, increases or decreases the displayed value by one
13	<i>[Menu]</i> Activates the main menu and toggles between menu items. Closes an opened sub menu
14	Display
15	<i>[Mic]</i> Microphone for sound control
16	<i>[Sound]</i> In "sound control" mode, the LED indicates that an audio signal is being received from the microphone
17	<i>[DMX]</i> The LED indicates that a signal is present at the DMX input
18	Antenna for Wireless DMX

19	<i>[POWER IN]</i> Lockable input socket (Power Twist) for power supply.
20	<i>[POWER OUT]</i> Lockable output socket (Power Twist) to supply an additional unit.
21	<i>[DMX IN]</i> DMX input.
22	<i>[DMX OUT]</i> DMX output
23	<i>[M10 mounting]</i> Thread for attachment, for example to a crossbar



Remote control

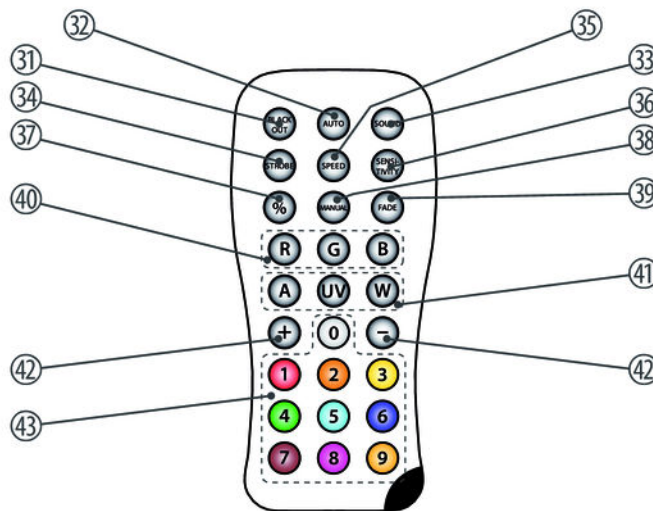

BEL6 Battery Event Light 6x15W

31	<i>[BLACK OUT]</i> Activates the blackout function and deactivates it again.
32	<i>[AUTO]</i> Starts / stops "Automatic" mode.
33	<i>[SOUND]</i> Starts the music-controlled automatic show.
34	<i>[STROBE]</i> Starts or stops the flashing light function (strobe effect) with the last colour selected.
35	<i>[SPEED]</i> Allows the speed of the automatic program to be adjusted via the <i>[+]</i> and <i>[-]</i> buttons.
36	<i>[SENSITIVITY]</i> Allows the sensitivity of the sound control to be adjusted with the <i>[+]</i> and <i>[-]</i> buttons.

37	<i>[%]</i> Resets the displayed value to zero when adjusting values (speed of the automatic program, sensitivity of the sound control).
38	<i>[MANUAL]</i> Activates the display of a constant colour, which you can custom-mix either using the <i>[R]</i> , <i>[G]</i> and <i>[B]</i> buttons from the primary colours or select it directly with one of the coloured buttons.
39	<i>[FADE]</i> Allows you to choose between the two automatic options via repeated pressing.
40	<i>[R]</i> , <i>[G]</i> , <i>[B]</i> When a constant colour is displayed, adjusts the intensity of the three primary colours red, green and blue.
41	<i>[A]</i> , <i>[UV]</i> , <i>[W]</i> When a constant colour is displayed, adjusts the intensity of the colours amber, white and UV.
42	<i>[+]</i> , <i>[-]</i> Increases or decreases the value set.
43	Buttons for directly selecting a mixed colour.

## **7 Operating**

### **7.1 Starting the device**

Connect the device to the power supply to start operation. After a few seconds, the display indicates that a reset is in progress. The device is then ready for use. The display shows the operating mode that was selected when the unit was last powered off.

## 7.2 Main menu

Press *[MENU]* to activate the main menu. Use the buttons *[UP]* and *[DOWN]* to select a style. When the display shows the desired submenu, press *[ENTER]*, to open it. To close the main menu, press *[MENU]*. The stored values are displayed in white in the display. Changed values are displayed in red until they are confirmed by pressing *[ENTER]*.

All previously made settings are retained even when you disconnect the device from the power grid. To restart with default values, use the function *'Factory Reset'*.

The following table shows the setting options.

Main menu	Menu level 2	Menu level 3	Menu level 4
Meaning			
'DMX Address'	001...507 (6-channel mode) 001...503 (10-channel mode)	Set the DMX address	
'Mode'	'DMX'	Select a DMX mode	

Main menu	Menu level 2	Menu level 3	Menu level 4	
Meaning				
		'DMX 6Ch'	6-channel DMX mode	
		'DMX 10Ch'	10-channel DMX mode	
	'Auto'	Automatic sequence with fade effect		
		'Fade'	'Sp00' ... 'Sp99'	Speed of the fade effect
	'Sound'	Sound-controlled automatic sequence		
		'Step'	'Se00' ... 'Se99'	Sensitivity of the built-in microphone
	'Static'	'Dimmer'	0...255	Setting for the overall brightness
		'Strobe'	0...255	Stroboscope effect with adjustable speed
		'C-Macro'	1...9	Selection of a mixed colour

Main menu	Menu level 2	Menu level 3	Menu level 4	
Meaning				
		'Red'	0...255	Intensity red (0 % to 100 %)
		'Green'	0...255	Intensity green (0 % to 100 %)
		'Blue'	0...255	Intensity blue (0 % to 100 %)
		'White'	0...255	Intensity white (0 % to 100 %)
		'Amber'	0...255	Intensity amber (0 % to 100 %)
		'UV'	0...255	Intensity UV (0 % to 100 %)
	'Slave'	'Slave'	Operating mode 'Slave'	
'Settings'	'W-Dmx'	Wireless control via DMX		

Main menu	Menu level 2	Menu level 3	Menu level 4
	<b>Meaning</b>		
		'On'	Disabled
		'Off'	Enabled
	'Display'	Automatically switch off the display when not in use	
		'On'	Enabled
		'Off'	Disabled
	'Display Rev'	Invert the display	
		'On'	On: the display is rotated 180°
		'Off'	Off: the normal display is shown
	'Limiter'	Lower the maximum brightness to extend battery life	
		'On'	Enabled
		'Off'	Disabled
	'DMX Fail'	Behaviour of the unit if the DMX signal fails	



Main menu	Menu level 2	Menu level 3	Menu level 4
	<b>Meaning</b>		
		<i>'Blackout'</i>	Blackout
		<i>'Sound'</i>	Sound-controlled automatic sequence
		<i>'Auto'</i>	Automatic sequence with fade effect
		<i>'Hold'</i>	Keep the most recent settings
	<i>'Dimmer Curve'</i>	Dimmer curve	
		<i>'Linear'</i>	Linear
		<i>'Exp'</i>	Exponential
		<i>'Log'</i>	Logarithmic
		<i>'S Curve'</i>	S-shaped
	<i>'System Info'</i>	<i>'Firmware'</i>	Display the firmware version of the unit
<i>'Timeinfo'</i>		Operating hours display	
<i>'Temperature'</i>		Display unit temperature	

## 7.3 Menu overview

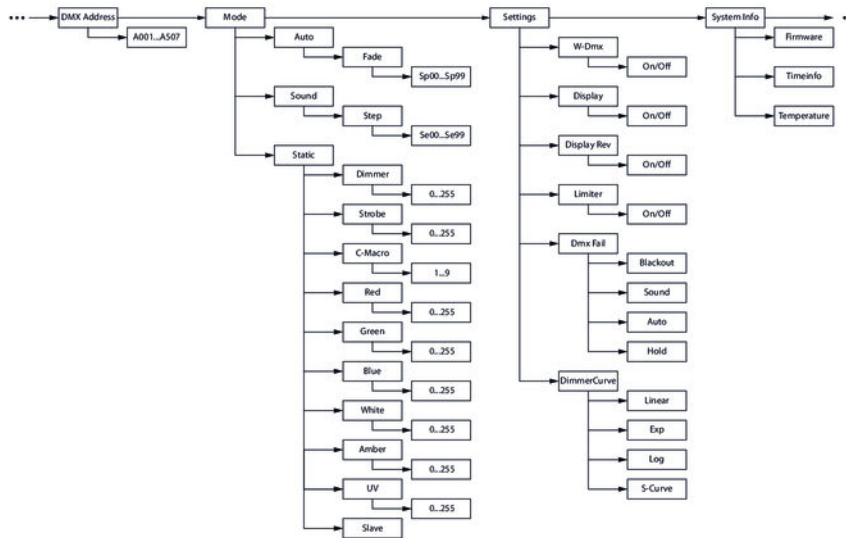

## 7.4 Functions in 6-channel DMX mode

Channel	Value	Function
1	0...255	Intensity red (0 % to 100 %)
2	0...255	Intensity green (0 % to 100 %)
3	0...255	Intensity blue (0 % to 100 %)
4	0...255	Intensity white (0 % to 100 %)
5	0...255	Intensity amber (0 % to 100 %)
6	0...255	Intensity UV (0 % to 100 %)

## 7.5 Functions in 10-channel DMX mode

Channel	Value	Function
1	0...255	Dimmer (0 % to 100 %), if channel 9 = 0...4
2	Strobe effect	
	0	Strobe closed
	1...255	Strobe effect with increasing speed, if channel 9 = 0...4
3	0...255	Intensity red (0 % to 100 %), if channel 9 = 0...4
4	0...255	Intensity green (0 % to 100 %), if channel 9 = 0...4
5	0...255	Intensity blue (0 % to 100 %), if channel 9 = 0...4
6	0...255	Intensity white (0 % to 100 %), if channel 9 = 0...4
7	0...255	Intensity amber (0 % to 100 %), if channel 9 = 0...4
8	0...255	Intensity UV (0 % to 100 %), if channel 9 = 0...4
9	Function selection	

Channel	Value	Function
	0...4	Colour and brightness settings via channels 1...8
	5...80	Selection of a mixed colour
	81...150	Colour change effect
	151...220	Colour transition effect
	221...255	Automatic sound-controlled show
10	0...255	Speed of the automatic show, increasing, if channel 9 = 81...220

## 8 Technical specifications

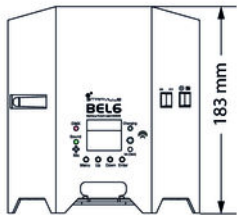
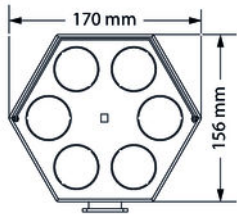

LEDs	Six six-colour LEDs (RGBAWUV, 15 W each)
Number of DMX channels	6 or 10, depending on operating mode
Beam angle	20°
Operating supply voltage	AC 100 – 240 V ~ 50/60 Hz Built-in rechargeable battery (lithium-Ion-battery, 11.1 V, 14400 mAh)
Operating time per battery charge	6 – 8 h (colour change) ... 20 h (one colour)
Power consumption	70 W
Protection	IP20
Dimensions (W × H × D)	170 mm × 183 mm × 156 mm
Weight	3.8 kg

**Environmental conditions**

Temperature range	0 °C...40 °C
Relative humidity	50 %, non-condensing

## 9 Plug and connection assignments

### Introduction

This chapter will help you select the right cables and plugs to connect your valuable equipment so that a perfect light experience is guaranteed.

Please take our tips, because especially in 'Sound & Light' caution is indicated: Even if a plug fits into a socket, the result of an incorrect connection may be a destroyed DMX controller, a short circuit or 'just' a not working light show!

### DMX connections



The unit offers a 3-pin XLR socket for DMX output and a 3-pin XLR plug for DMX input. Please refer to the drawing and table below for the pin assignment of a suitable XLR plug.

Pin	Configuration
1	Ground, shielding
2	Signal inverted (DMX-, 'cold signal')
3	Signal (DMX+, 'hot signal')



## 10 Troubleshooting



### **NOTICE!**

#### **Possible data transmission errors**

For error-free operation make use of dedicated DMX cables and do not use ordinary microphone cables.

Never connect the DMX input or output to audio devices such as mixers or amplifiers.

In the following we list a few common problems that may occur during operation. We give you some suggestions for easy troubleshooting:

Symptom	Remedy
Device not working, no light	Check the mains connection and the main fuse.
Not responding to DMX controller	1. Check the DMX connectors and cables to see if they are properly linked.
	2. Check the address settings and the DMX polarity.
	3. Try using another DMX controller.
	4. Check whether the DMX cables run near or parallel to high-voltage cables that may cause damage or interference to the DMX interface circuit.
The built-in battery can no longer be recharged	Do not attempt to replace the built-in battery yourself. Please contact our service centre.

If the procedures recommended above do not succeed, please contact our Service Center. You can find the contact information at [www.thomann.de](http://www.thomann.de).

# 11 Cleaning

## Optical lenses

Clean the optical lenses, that are accessible from the outside, regularly in order to optimize the light output. The frequency of cleaning depends on the operating environment: wet, smoky or particularly dirty surroundings can cause more accumulation of dirt on the optics of the device.

- Clean with a soft cloth using our lamp and lens cleaner (item no. 280122).
- Always dry the parts carefully.

## Fan grids

The fan grids of the device must be cleaned on a regular basis to remove dust and dirt. Before cleaning, switch off the device and disconnect AC-powered devices from the mains. Use a lint-free damp cloth for cleaning. Never use solvents or alcohol for cleaning.

## 12 Protecting the environment

### Disposal of the packaging material



For the packaging, environmentally friendly materials have been chosen that can be supplied to normal recycling.

Ensure that plastic bags, packaging, etc. are properly disposed of.

Do not just dispose of these materials with your normal household waste, but make sure that they are collected for recycling. Please follow the notes and markings on the packaging.

### Disposal of batteries



Batteries do contain some hazardous chemicals so they should not be thrown away with the normal household waste. They should be returned to the manufacturer for disposal or recycled elsewhere in accordance with your local regulations.

Remove lithium batteries from the device before disposal. Protect used lithium batteries against short circuit, for example by taping the poles.

### Disposal of your old device



This product is subject to the European Waste Electrical and Electronic Equipment Directive (WEEE) in its currently valid version. Do not dispose with your normal household waste.

Dispose of this device through an approved waste disposal firm or through your local waste facility. When discarding the device, comply with the rules and regulations that apply in your country. If in doubt, consult your local waste disposal facility.





