



LED Pad 7
7x10W 6in1 RGBWAUV

LED PAR

Musikhaus Thomann
Thomann GmbH
Hans-Thomann-Straße 1
96138 Burgebrach
Germany
Telephone: +49 (0) 9546 9223-0
E-mail: info@thomann.de
Internet: www.thomann.de

01.07.2020, ID: 390703, 428171 (V2)

Table of contents

1	General information	6
	1.1 Further information.....	7
	1.2 Notational conventions.....	8
	1.3 Symbols and signal words.....	8
2	Safety instructions	11
3	Features	18
4	Installation	19
5	Starting up	22
6	Connections and controls	26
7	Operating	34
	7.1 Starting the device.....	34
	7.2 Main menu.....	34
	7.3 Menu overview.....	40
	7.4 Function in 1-channel DMX mode.....	41
	7.5 Functions in 6-channel DMX mode.....	41

7.6	Functions in 7-channel DMX mode.....	42
7.7	Functions in 10-channel DMX mode.....	43
8	Technical specifications.....	45
9	Plug and connection assignments.....	48
10	Troubleshooting.....	49
11	Cleaning.....	51
12	Protecting the environment.....	52



LED Pad 7 7x10W 6in1 RGBWAUV
LED PAR

1 General information

This user manual contains important information on the safe operation of the device. Read and follow all safety notes and all instructions. Save this manual for future reference. Make sure that it is available to all persons using this device. If you sell the device to another user, be sure that they also receive this manual.

Our products and user manuals are subject to a process of continuous development. We therefore reserve the right to make changes without notice. Please refer to the latest version of the user manual which is ready for download under www.thomann.de.

1.1 Further information

On our website (www.thomann.de) you will find lots of further information and details on the following points:

Download	This manual is also available as PDF file for you to download.
Keyword search	Use the search function in the electronic version to find the topics of interest for you quickly.
Online guides	Our online guides provide detailed information on technical basics and terms.
Personal consultation	For personal consultation please contact our technical hotline.
Service	If you have any problems with the device the customer service will gladly assist you.

1.2 Notational conventions

This manual uses the following notational conventions:

Letterings

The letterings for connectors and controls are marked by square brackets and italics.

Examples: *[VOLUME]* control, *[Mono]* button.



Displays



Texts and values displayed on the device are marked by quotation marks and italics.

Examples: *'24ch'*, *'OFF'*.

1.3 Symbols and signal words

In this section you will find an overview of the meaning of symbols and signal words that are used in this manual.

Signal word	Meaning
DANGER!	This combination of symbol and signal word indicates an immediate dangerous situation that will result in death or serious injury if it is not avoided.
WARNING!	This combination of symbol and signal word indicates a possible dangerous situation that can result in death or serious injury if it is not avoided.
NOTICE!	This combination of symbol and signal word indicates a possible dangerous situation that can result in material and environmental damage if it is not avoided.
Warning signs	Type of danger
	Warning – high-voltage.
	Warning – dangerous optical radiation.

Warning signs	Type of danger
 A yellow triangular warning sign with a black border, depicting a crane hook lifting a rectangular load.	Warning – suspended load.
 A yellow triangular warning sign with a black border, featuring a large black exclamation mark.	Warning – danger zone.

2 Safety instructions

Intended use

This device is intended for use as an electronic lighting effect by means of LED technology. The device is designed for professional use and is not suitable for use in households. Use the device only as described in this user manual. Any other use or use under other operating conditions is considered to be improper and may result in personal injury or property damage. No liability will be assumed for damages resulting from improper use.

This device may be used only by persons with sufficient physical, sensorial, and intellectual abilities and having corresponding knowledge and experience. Other persons may use this device only if they are supervised or instructed by a person who is responsible for their safety.

Extend the life of the device by regular breaks in operation and avoid switching it on and off frequently. This device is not suitable for continuous use.

Safety



DANGER!

Danger for children

Ensure that plastic bags, packaging, etc. are disposed of properly and are not within reach of babies and young children. Choking hazard!

Ensure that children do not detach any small parts (e.g. knobs or the like) from the unit. They could swallow the pieces and choke!

Never let children unattended use electrical devices.



DANGER!

Electric shock caused by high voltages inside

Within the device there are areas where high voltages may be present. Never remove any covers.

There are no user-serviceable parts inside.

Do not use the device if covers, protectors or optical components are missing or damaged.



DANGER!

Electric shock caused by short-circuit

Always use proper ready-made insulated mains cabling (power cord) with a protective contact plug. Do not modify the mains cable or the plug. Failure to do so could result in electric shock/death or fire. If in doubt, seek advice from a registered electrician.



WARNING!

Eye damage caused by high light intensity

Never look directly into the light source.



WARNING!

Risk of epileptic shock

Strobe lighting can trigger seizures in photosensitive epilepsy. Sensitive persons should avoid looking at strobe lights.



NOTICE!

Risk of fire

Do not block areas of ventilation. Do not install the device near any direct heat source. Keep the device away from naked flames.

**NOTICE!****Operating conditions**

This device has been designed for indoor use only. To prevent damage, never expose the device to any liquid or moisture. Avoid direct sunlight, heavy dirt, and strong vibrations.

Only operate the device within the ambient conditions specified in the chapter 'Technical specifications' of this user manual. Avoid heavy temperature fluctuations and do not switch the device on immediately after it was exposed to temperature fluctuations (for example after transport at low outside temperatures).

Dust and dirt inside can damage the unit. When operated in harmful ambient conditions (dust, smoke, nicotine, fog, etc.), the unit should be maintained by qualified service personnel at regular intervals to prevent overheating and other malfunction.



NOTICE!

Power supply

Before connecting the device, ensure that the input voltage (AC outlet) matches the voltage rating of the device and that the AC outlet is protected by a residual current circuit breaker. Failure to do so could result in damage to the device and possibly injure the user.

Unplug the device before electrical storms occur and when it is unused for long periods of time to reduce the risk of electric shock or fire.



NOTICE!

Possible damage due to installation of a wrong fuse

The use of different types of fuses can cause serious damage to the unit. Fire hazard!

Only fuses of the same type may be used.



NOTICE!

Possible staining

The plasticiser contained in the rubber feet of this product may possibly react with the coating of your parquet, linoleum, laminate or PVC floor and after some time cause permanent dark stains.

In case of doubt, do not put the rubber feet directly on the floor, but use felt-pad floor protectors or a carpet.

3 Features

The device is suitable for almost all applications, for example in clubs, bars, small stages and theatres. It is characterized by small size, solid construction also for use 'on tour' and enormous power.

Special features of the device:

- 7 × 10 W 6in1 RGBWAUV LEDs
- 6 colours per lens, so that almost any colour can be mixed
- with double bracket for easy setup or mounting
- Control via DMX, the supplied IR remote control and via buttons and display on the unit
- Automatic mode and sound control
- Master / Slave operation

For technological reasons, the light output of LEDs decreases over their lifetime. This effect increases with higher operating temperature. You can extend the service life of the illuminants by providing adequate ventilation and operating the LEDs with the lowest possible brightness.

4 Installation

Unpack and check carefully there is no transportation damage before using the unit. Keep the equipment packaging. To fully protect the product against vibration, dust and moisture during transportation or storage use the original packaging or your own packaging material suitable for transport or storage, respectively.

You can install the device on the wall, the ceiling or on the floor. A two-piece mounting bracket with locking screws is included in the package.



WARNING!

Risk of injury caused by falling objects

Make sure that the installation complies with the standards and rules that apply in your country. Always secure the device with a secondary safety attachment, such as a safety cable or a safety chain.



NOTICE!

Risk of overheating

The distance between light output and the illuminated surface must be more than 1.5 m (19.7in).

Provide sufficient ventilation.

The ambient temperature must always be below 40 °C (104 °F).



NOTICE!

Use of stands

When mounting the device onto a stand, ensure that the stand is in a safe and stable position and that the weight of the device does not exceed the maximum permissible load capacity of the stand.



NOTICE!

Possible data transmission errors

For error-free operation make use of dedicated DMX cables and do not use ordinary microphone cables.

Never connect the DMX input or output to audio devices such as mixers or amplifiers.



Please note that this device must not be connected to a dimmer.

5 Starting up

Create all connections while the device is off. Use the shortest possible high-quality cables for all connections. Take care when running the cables to prevent tripping hazards.

Connections in DMX mode

Connect the DMX input of the device to the DMX output of a DMX controller or another DMX device. Connect the output of the first DMX device to the input of the second one, and so on to form a daisy chain. Always ensure that the output of the last DMX device in the daisy chain is terminated with a resistor ($110\ \Omega$, $\frac{1}{4}\ \text{W}$).

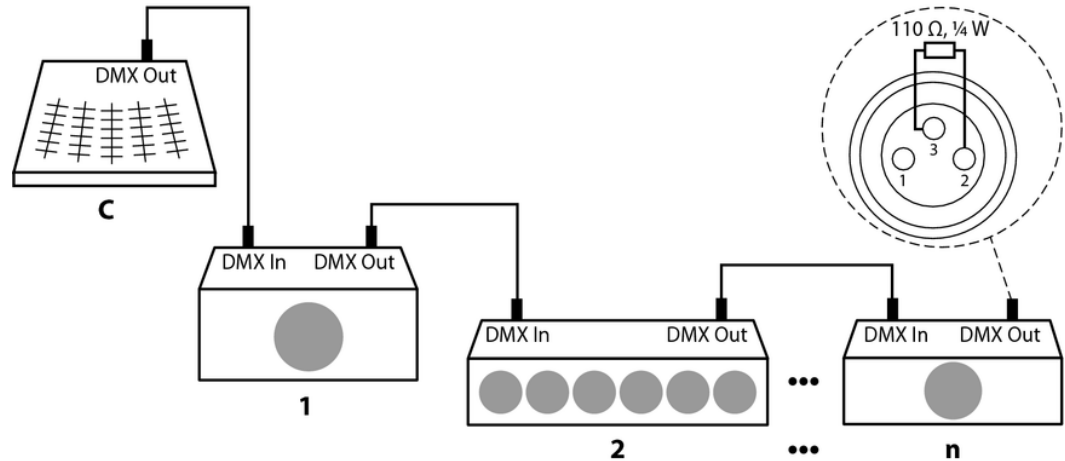

Connections in master/slave mode

When you configure a group of devices in master/slave mode, the first unit will control the other units for an automatic, sound-activated, synchronized show. This function is ideal when you want to start a show immediately. Connect the DMX output of the master device to the DMX input of the first slave device. Then connect the DMX output of the first slave device to the DMX input of the second slave device and so on.



Please note that this device must not be connected to a dimmer.

Inserting the battery into the remote control

Press the lock of the battery holder to the centre of the housing and pull out the battery holder like a drawer. Insert the battery. The battery is correct if the positive pole points to the housing base of the remote control. Slide the battery holder back into the remote until it clicks into place.

When shipping, the battery is already installed in the remote and protected against discharge by a transparent plastic foil. Remove the plastic foil prior to first use.

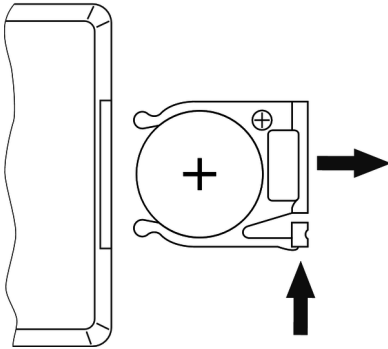

6 Connections and controls

Front panel

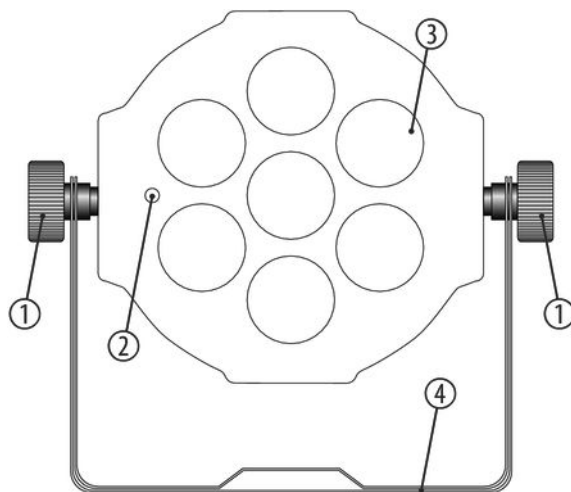

1	Locking screw for the bracket.
2	Infrared sensor for receiving signals from the remote control
3	LEDs
4	Bracket for floor placement or hanging

Rear panel

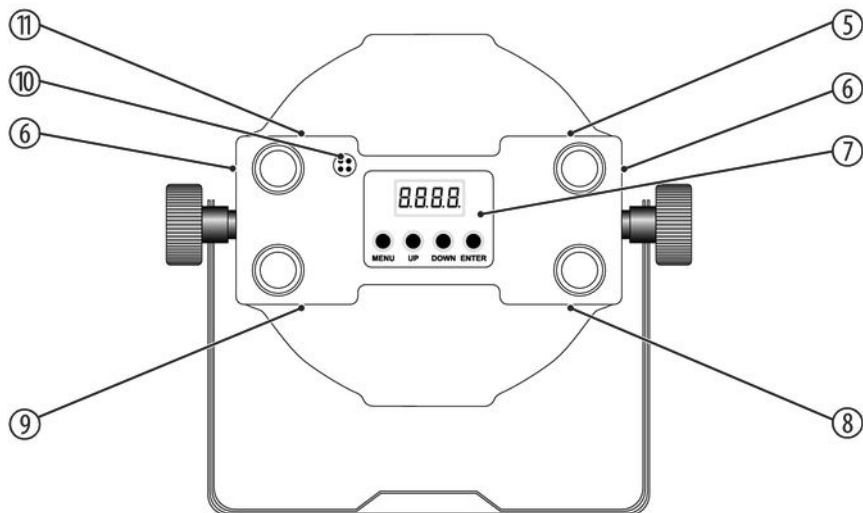

5	<i>[DMX IN]</i> DMX input
6	Fan
7	Display and operating elements <i>[ENTER]</i> Confirms a selected value. <i>[DOWN]</i> Button to decrease the displayed value by one. <i>[UP]</i> Button to increase the displayed value by one. <i>[MENU]</i> Calls up the main menu or a submenu.
8	<i>[DMX OUT]</i> DMX output

9	<i>[POWER OUT]</i> IEC chassis socket for the power supply of further devices
10	Microphone for sound control
11	<i>[100-240V~50/60Hz]</i> Mains connection socket, designed as IEC chassis plug

Remote control

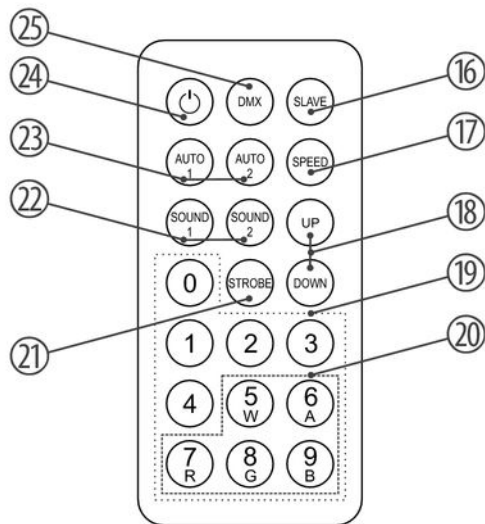

15	<i>[SLAVE]</i> Toggles operating modes 'Master' and 'Slave'.
16	<i>[SPEED]</i> Activates the setting mode for the programme speed. Adjust the speed using the buttons <i>[UP]</i> and <i>[DOWN]</i> .
17	<i>[UP / DOWN]</i> To select a desired program or increase / decrease a parameter value.
18	<i>[0 ... 9]</i> To make numeric settings.
19	<i>[W], [A], [R], [G], [B]</i> To switch the specified base colour on and off.
20	<i>[STROBE]</i> Turns the strobe function on / off.
21	<i>[SOUND 1 & 2]</i> Activates sound-controlled mode 1 or 2

- | | |
|----|---|
| 22 | <i>[AUTO 1 & 2]</i>
Activates the 'preprogrammed automatic show' 1 or 2. |
| 23 | <i>[POWER]</i>
Activates or deactivates the device. |
| 24 | <i>[DMX]</i>
Press once to set the DMX address. After pressing twice, the DMX mode can be set. |

7 Operating

7.1 Starting the device

Connect the device to the power supply to start operation.

7.2 Main menu

Press *[MENU]* to activate the main menu. Use *[UP]* / *[DOWN]* to change the respectively indicated value. When the display shows the desired value press *[ENTER]*.

DMX address

Press *[MENU]*. Press *[UP]* / *[DOWN]* repeatedly until the display shows 'Addr'. Press *[ENTER]*. Now you can set the number of the first DMX channel to be used by the device (DMX address). Use *[UP]* / *[DOWN]* to select a value between 1 and 512 (the display shows 'A001' ... 'A512').

When the display shows the desired value press *[ENTER]* to confirm the selection and then *[MENU]* to return to the parent menu. To return to the parent menu without making changes, press *[MENU]*.

Make sure that this number matches the configuration of your DMX controller. The following table shows the highest possible DMX address for the various DMX modes.

Mode	Highest possible DMX address
1-channel	512
6-channel	507
7-channel	506
10-channel	503

DMX mode

Press *[MENU]*. Press *[UP]* / *[DOWN]* repeatedly until the display shows 'Chnd'. Press *[ENTER]*. With *[UP]* or *[DOWN]* you can now select one of the following DMX modes:

- '1Ch' (one channel)
- '6Ch' (six channels)
- '7Ch' (seven channels)
- '10Ch' (ten channels)

This setting is only relevant when the device is controlled via DMX. When the display shows the desired value press *[ENTER]* to confirm the selection and then *[MENU]* to return to the parent menu. To return to the parent menu without making changes, press *[MENU]*.

Operating mode 'Auto 1' / 'Auto 2'

Press *[MENU]*. Press *[UP]* / *[DOWN]* repeatedly until the display shows 'Auto'. Press *[ENTER]*. With *[UP]* / *[DOWN]* you can now select one of the two preprogrammed automatic shows 'AUT1' or 'AUT2'. Press *[ENTER]*. Use *[UP]* / *[DOWN]* to select a value for the programme speed between 1 and 9 (display shows 'SP-1' ... 'SP-9'). Press *[ENTER]*. Then use *[UP]* / *[DOWN]* to select a value for the strobe frequency between 00 and 99 (display shows 'St00' ... 'St99'). When the display shows the desired value press *[ENTER]* to confirm the selection and then *[MENU]* to return to the parent menu. To return to the parent menu without making changes, press *[MENU]*.

This setting is only relevant if the device is not controlled via DMX. The device can operate in stand-alone mode or control connected devices of the same type, that must be configured as slaves. The auto show can only be activated on the master device.

Colour selection

Press *[MENU]*. Press *[UP]* / *[DOWN]* repeatedly until the display shows 'CoLo'. Press *[ENTER]*. With *[UP]* / *[DOWN]* you can now select a colour 'Co01' to 'Co51'. When the display shows the desired value press *[ENTER]* to confirm the selection. Then use *[UP]* / *[DOWN]* to select a value for the strobe frequency between 00 and 99 (display shows 'St00' ... 'St99'). When the display shows the desired value press *[ENTER]* to confirm the selection and then *[MENU]* to return to the parent menu. To return to the parent menu without making changes, press *[MENU]*.

Dimmer setting

Press *[MENU]*. Press *[UP]* / *[DOWN]* repeatedly until the display shows 'StAt'. Press *[ENTER]*. Press *[UP]* / *[DOWN]* repeatedly until the display shows 'red' (for red), 'Gree' (for green), 'bLue' (for blue), 'Uhit' (for white), 'Anbe' (for amber) or 'PUrP' (for UV). When the display shows the desired value press *[ENTER]* to confirm the selection. Then use *[UP]* / *[DOWN]* to select a value for the dimmer setting between 000 and 255 (display shows 'r000' ... 'r255', 'g000' ... 'g255', 'b000' ... 'b255', 'U000' ... 'U255', 'A000' ... 'A255') or 'P000' ... 'P255'). When the display shows the desired value press *[ENTER]* to confirm the selection. Then use *[UP]* / *[DOWN]* to select a value for the strobe frequency between 00 and 99 (display shows 'St00' ... 'St99'). When the display shows the desired value press *[ENTER]* to confirm the selection and then *[MENU]* to return to the parent menu. To return to the parent menu without making changes, press *[MENU]*.

Sound control

Press *[MENU]*. Press *[UP]* / *[DOWN]* repeatedly until the display shows 'Soun'. Press *[ENTER]*. With *[UP]* / *[DOWN]* you can now select one of the two sound modes 'Sou1' or 'Sou2'. Press *[ENTER]*. Use *[UP]* / *[DOWN]* to select a value for the microphone sensitivity between 0 and 9 (display shows 'SENO' ... 'SEN9'). When the display shows the desired value press *[ENTER]* to confirm the selection and then *[MENU]* to return to the parent menu. To return to the parent menu without making changes, press *[MENU]*.

Operating mode 'Slave'

Press *[MENU]*. Press *[UP]* / *[DOWN]* repeatedly until the display shows 'SLAV'. Press *[ENTER]*. The display now shows 'SLA'. The device is now configured as slave and follows the settings of the master device to which it is connected. In the other operating modes, the device automatically operates as master. Press *[MENU]* to return to the parent menu. This setting is only relevant if the device is not controlled via DMX.

Remote control

Press *[MENU]*. Press *[UP]* / *[DOWN]* repeatedly until the display shows 'rEno'. With *[UP]* / *[DOWN]* you can now either enable (display shows 'on') or disable (display shows 'oFF') the remote control function. When the display shows the desired value press *[ENTER]* to confirm the selection and then *[MENU]* to return to the parent menu. To return to the parent menu without making changes, press *[MENU]*.

Temperature

Press *[MENU]*. Press *[UP]* / *[DOWN]* repeatedly until the display shows 'tenP'. Press *[ENTER]*. The display shows the current operating temperature.

Software version display

Press *[MENU]*. Press *[UP]* / *[DOWN]* repeatedly until the display shows 'Uer'. Press *[ENTER]*. The display now shows the current software version with 'vXX'. To return to the parent menu, press *[MENU]*.

7.3 Menu overview

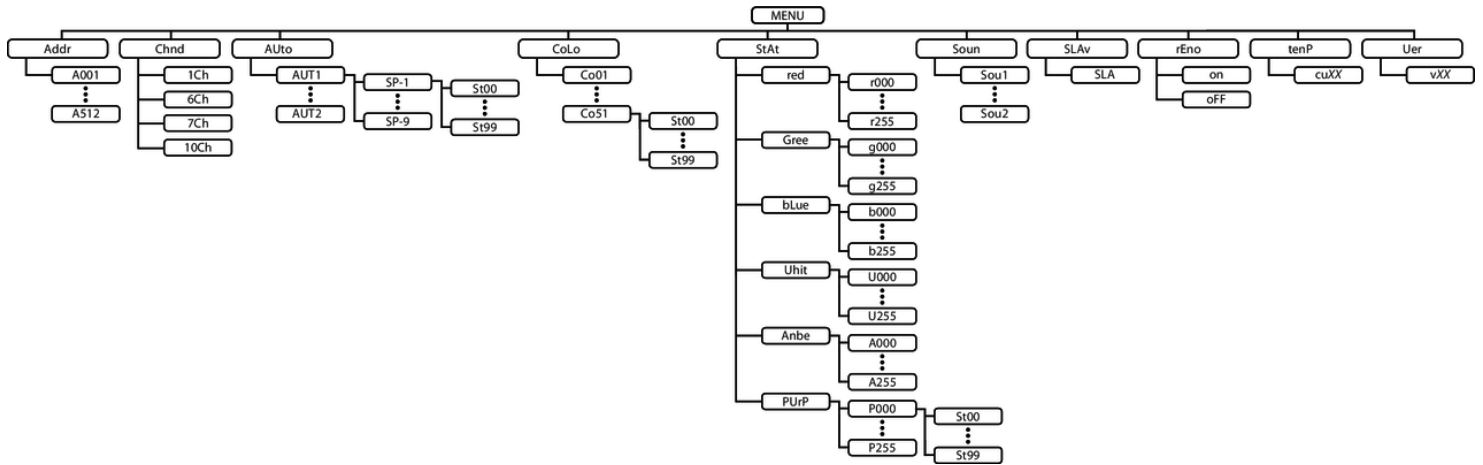

7.4 Function in 1-channel DMX mode

Channel	Value	Function
1	0...255	Colour selection

7.5 Functions in 6-channel DMX mode

Channel	Value	Function
1	0...255	Intensity red (0 % to 100 %)
2	0...255	Intensity green (0 % to 100 %)
3	0...255	Intensity blue (0 % to 100 %)
4	0...255	Intensity white (0 % to 100 %)
5	0...255	Intensity amber (0 % to 100 %)
6	0...255	Intensity UV (0 % to 100 %)

7.6 Functions in 7-channel DMX mode

Channel	Value	Function
1	0...255	Intensity (0 % to 100 %)
2	0...255	Intensity red (0 % to 100 %)
3	0...255	Intensity green (0 % to 100 %)
4	0...255	Intensity blue (0 % to 100 %)
5	0...255	Intensity white (0 % to 100 %)
6	0...255	Intensity amber (0 % to 100 %)
7	0...255	Intensity UV (0 % to 100 %)

7.7 Functions in 10-channel DMX mode

Channel	Value	Function
1	0...255	Intensity (0 % to 100 %)
2	0...255	Intensity red (0 % to 100 %)
3	0...255	Intensity green (0 % to 100 %)
4	0...255	Intensity blue (0 % to 100 %)
5	0...255	Intensity white (0 % to 100 %)
6	0...255	Intensity amber (0 % to 100 %)
7	0...255	Intensity UV (0 % to 100 %)
8	0...50	No function
	51...101	Auto mode 1
	102...152	Auto mode 2
	153...203	Sound mode 1

Channel	Value	Function
	204...255	Sound mode 2
9	0...255	Automatic show speed, slow to fast, if channel 8 = 51...152
	0...255	Microphone sensitivity, if channel 8 = 153...255 (0 to 29: microphone off, 30 to 255 = low to high)
10	0...9	No function
	10...255	Strobe frequency slow to fast

8 Technical specifications

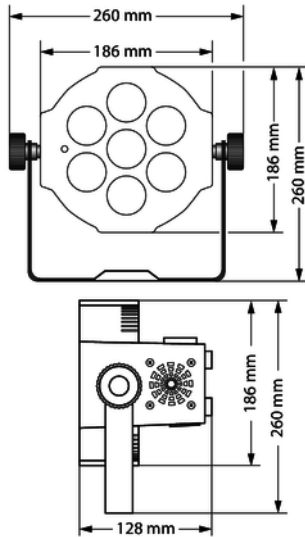

Light source	7 × 6-in1 LEDs (RGBWAUV), each 10 W	
Optical properties	Beam angle	25°
Control	DMX, infrared remote control, buttons and display on the device	
Number of DMX channels	1, 6, 7 or 10	
Input connections	Power supply	IEC chassis plug C14
	DMX control	XLR chassis socket, 3-pin
Output connections	Power supply of further devices	IEC chassis plug C13
	DMX control	XLR chassis socket, 3-pin
Power consumption	70 W	
Supply voltage	100 – 240 V ~ 50/60 Hz	
Fuse	5 mm × 20 mm, 3.15 A, 250 V, fast-acting	

Degree of protection	IP20	
Mounting options	hanging	
Dimensions (W × H × D)	186 × 186 × 128 mm (without bracket) 260 × 260 × 128 mm (incl. bracket)	
Weight	1.9 kg	
Ambient conditions	Temperature range	0 °C...40 °C
	Relative humidity	50 %, non-condensing

Further information

Construction	Flat PAR
Colour mixture	RGBAWUV
LED type	x-in-1
Base housing	Yes
Fanless	No
Remote control	included
Wireless DMX	No
Housing colour	Item no. 390703: white Item no. 428171: black

9 Plug and connection assignments

Introduction

This chapter will help you select the right cables and plugs to connect your valuable equipment so that a perfect light experience is guaranteed.

Please take our tips, because especially in 'Sound & Light' caution is indicated: Even if a plug fits into a socket, the result of an incorrect connection may be a destroyed DMX controller, a short circuit or 'just' a not working light show!

DMX connections

The unit offers a 3-pin XLR socket for DMX output and a 3-pin XLR plug for DMX input. Please refer to the drawing and table below for the pin assignment of a suitable XLR plug.



Pin	Configuration
1	Ground, shielding
2	Signal inverted (DMX-, 'cold signal')
3	Signal (DMX+, 'hot signal')

10 Troubleshooting



NOTICE!

Possible data transmission errors

For error-free operation make use of dedicated DMX cables and do not use ordinary microphone cables.

Never connect the DMX input or output to audio devices such as mixers or amplifiers.

In the following we list a few common problems that may occur during operation. We give you some suggestions for easy troubleshooting:

Symptom	Remedy
The unit does not work, no light	Check the mains connection.
Apparently no function despite proper power supply	Check if the unit is in DMX mode or in 'slave' mode. If so, check the unit in another mode.
No response to the DMX controller	<ol style="list-style-type: none">1. Check whether the DMX controller is switched on. Check the DMX connectors and cables for proper connection.2. Check the address settings and the DMX polarity.3. Try using another DMX controller.4. Check whether the DMX cables run near or parallel to high-voltage cables that may cause damage or interference to a DMX interface circuit.

If the procedures recommended above do not succeed, please contact our Service Center. You can find the contact information at www.thomann.de.

11 Cleaning

Optical lenses

Clean the optical lenses, that are accessible from the outside, regularly in order to optimize the light output. The frequency of cleaning depends on the operating environment: wet, smoky or particularly dirty surroundings can cause more accumulation of dirt on the optics of the device.

- Clean with a soft cloth using our lamp and lens cleaner (item no. 280122).
- Always dry the parts carefully.

Fan grids

The fan grids of the device must be cleaned of any contamination, such as dust, etc. on a regular basis. Before cleaning, switch off the device and disconnect mains-operated devices from the mains. Only use pH-neutral, solvent-free and non-abrasive cleaning agents. Clean the unit with a slightly damp lint-free cloth.

12 Protecting the environment

Disposal of the packaging material



For the transport and protective packaging, environmentally friendly materials have been chosen that can be supplied to normal recycling.

Ensure that plastic bags, packaging, etc. are properly disposed of.

Do not just dispose these materials with your normal household waste, but make sure that they are fed to a recovery. Please follow the notes and markings on the packaging.

Disposal of batteries



Batteries must not be disposed of as domestic waste or thrown into fire. Dispose of the batteries according to national or local regulations regarding hazardous waste. To protect the environment, dispose of empty batteries at your retail store or at appropriate collection sites.

Disposal of your old device



This product is subject to the European Waste Electrical and Electronic Equipment Directive (WEEE) in its currently valid version. Do not dispose with your normal household waste.

Dispose this device through an approved waste disposal firm or through your local waste facility. When discarding the device, comply with the rules and regulations that apply in your country. If in doubt, consult your local waste disposal facility.

