



**V-1**

USER'S MANUAL

---

## Table of content

1.	Safety instructions.....	3
1.1.	For safe and efficient operation.....	3
2.	Intended use of the device.....	4
2.1.	Overhead installation.....	5
2.2.	Connections .....	6
2.2.1.	Electrical connections.....	6
2.2.2.	DMX connections.....	7
2.3.	DMX connection with terminator.....	7
3.	Introduction.....	8
3.1.	Product description .....	8
4.	Before using.....	9
5.	Control buttons.....	9
6.	User Interface.....	10
6.1.	Status interface .....	10
6.2.	Menu.....	11
6.3.	DMX Interface .....	11
7.	Error.....	12
8.	Operation .....	13
8.1.	Manual Operation.....	13
8.2.	Operation via DMX.....	13
9.	Settings.....	14
9.1.	DMX address.....	14
9.2.	Fan speed setting .....	14
9.3.	Manual operation.....	14
10.	RFID card .....	14
10.1.	How to use the card .....	14
10.2.	How to check the remaining time.....	14
11.	Technical dato .....	15

## 1. Safety instructions



- This device is suitable for indoor use (not outdoors) only.
- Unauthorized modifications will invalidate the warranty.
- Repairs are to carry out by skilled workers only.
- Use only fuses of the same type and original parts as spare parts.
- To avoid fire and electric shocks protect the unit from rain and humidity.

### 1.1. For safe and efficient operation

#### **Be careful with heat and extreme temperatures!**

Do not place the device in a location where it is exposed to extreme temperatures.

Operate the device only in an ambient temperature between 0°C (32°F) - 40°C (104°F). Do not expose the device to direct sunlight or heat sources.

#### **Keep away from humidity, water and dust!**

Avoid placing the device in a location with high humidity or excessive dust. Place no liquids on or near the system.

#### **Place the device on a firm ground!**

To avoid vibrations always place the device on a firm ground.

#### **Do not use chemicals for cleaning!**

Use a clean and dry cleaning rag to remove dust. Metal parts can be cleaned with a dampened cleaning rag. Before cleaning always unplug the device from the power supply.

#### **If the device is not working properly!**

If problems occur unplug the device from the power supply. The user should not try to service the device independently. All repairs and service must be performed by a qualified technician.

#### **Take proper care with the power cord!**

Never pull the power cord to disconnect the device from the power supply, but remove the plug with plug housing in the hand. If you do not use the device for an extended period, unplug the device from the power supply.

#### **ATTENTION!**

Damages caused by the disregard of this user manual are not subject to warranty. The dealer will not accept liability for any consequent secondary failures. Only skilled workers are allowed to carry out the electrical connections. All electrical and mechanical connections have to be carried out according to the European safety standards.

---

## 2. Intended use of the device

This device was developed for professional use on stages, in discos, theatres etc. The device is only approved for a connection up to 230 V 50/60 Hz alternating current and only for indoor use.

Regular breaks during operation increase the lifetime of your device.

Avoid convulsions or any form of forceful impact during the installation or the startup of the device.

Take care that no cables are lying around. You would endanger your own safety and also the safety of a third party.

It is not allowed to operate or store the device in an environment in which spray water or rain is expected. Humidity or very high atmospheric humidity could reduce the isolation of the device and could cause deathly electric shocks.

If using fog machine you have to ensure that the fog saturation of the room must allow a good visibility of at least 10m.

Operate the device not during thunderstorms. Surge voltages could destroy the device. Unplug the power supply during thunderstorms.

Surrounding objects or surfaces should not be in contact with the device.

Make sure that during the installation and removal of the device the area below the place of installation is basically cordoned off. This also applies to implementation of service.

Make familiar yourself with the functions of the device before start-up. People without the experience should not handle with the device. The most cause of functional disorder is inappropriate handling.

Keep the device away from children and never operate it unattended.

Never aim the nozzle on people a keep a distance from 50 cm to the nozzle. ATTENTION. The ejected fog is very hot!

Keep a minimum distance of 50 cm to other objects.

Use only the recommended, high quality granule from your dealer. Other fluids may cause damages.

Never aim the nozzle on open fire or flammable objects.

Operate the unit only in a horizontal position.

Never use solvents or aggressive detergents for cleaning. Use instead of this a damped cleaning rag.

To prevent damages during transport use for transport the original packing or provided accessories.

**For reasons of safety unauthorized changes are forbidden!**

A usage of the device which differs from usages which are described in this manual can cause damages of the device. In this case the warranty expires. Additional you should notice that every different usage is related with dangers and can cause e.g. an electrical short, fire, electric shock or crash.

## 2.1. Overhead installation



### Danger of life!

You have to observe the regulations of BGV C1 (formerly VBG 70) and EN60598-2-17 Installations are to carry out by skilled personnel only.

The suspension devices have to be build and measured so they can withstand for an hour the tenfold of the payload without suffering a permanent detrimental deformation.

Basically installation has to be made by using a second separate suspension. This can be e.g. a suitable net. The second suspension must be designed and attached so no part of the installation can fall down in case of failure.

During construction, reconstruction and deconstruction unnecessary stay in the range of moving areas, on lightning bridges, under elevated work stations or any other danger zones is forbidden.

The operator is obliged to following safety-related and mechanical facilities:

- Before the first start-up or after critical changes before restarting it has to be checked by an expert.
- Review in the frame of the inspection test at least all four years by an expert. .
- Review by a qualified person at least once a year.

### How to carry out the overhead installation:

Ideally the device should be installed outside lounge areas of people.

**IMPORTANT!** Overhead installation requires a high level of experience. This includes knowledge of calculating the payload, used installation material and safety inspections of the used material and the projector whereas the required experience is not limited to this. Do not try to carry out installation yourself under any circumstances if you are not qualified. Contact a professional installer. An inappropriate installation can lead to injuries and/or damaged properties.

It is not allowed to install the device in the grip area of people.

If the device may hang from the ceiling or from high beams, the use of truss systems is mandatory. The device may not be installed so it can swing freely in the room.

Please note: Crashing down items can cause serious injuries! Do not install the projector, if you doubt the safety of a possible installation form!

Before installation make sure that the mounting surface has the ability to carry the tenfold point load of the own weight of the device.

Mount the device with the mounting-bracket to your trussing system using an appropriate clamp.

During overhead installation the device must be always secured by a safety rope which is designed to hold the twelfold weight of device. Only safety ropes with quick-release safety fastener elements may be used. Hang up the safety rope in the hole of the mounting bracket. Direct the rope over the truss or an appropriate fastening point. Hang up the end in the fastening element and tie up the locking nut. A safety rope once exposed to failing load or damaged may not be used furthermore.

**The maximum drop exceed must not exceed 20cm.**

A safety rope once exposed to failing load or damaged may not be used furthermore. Adjust the desired inclination angle via the mounting bracket and tighten the screw.

## 2.2. Connections

### 2.2.1. Electrical connections

Connect the fixture to the mains with the enclosed power cable and plug. The earth has to be connected.

Cable (EU)	Cable (US)	Pin	International
Brown	Black	Live	L
Light blue	White	Neutral	N
Yellow/Green	Green	Earth	

---

### **2.2.2. DMX connections**

Make sure that you use shielded cable. 3pol or 5pol XLR cables are suitable.

### **2.3. DMX connection with terminator**

Where the DMX cable has to run a long distance or the equipment is operated in an electrically noisy environment like a disco for installations, we recommend using a DMX terminator. This prevents corruption of the digital control signal by electrical noise. The DMX terminator is simply an XLR connector with a 120  $\Omega$  resistor between pins 2 and 3, which is then plugged into the XLR output socket of the last device in the series. Please look to the bottom drawings.

### 3. Introduction

Thank you for choosing the **DJPOWER V-1**.

We recommend that you carefully read these operating instructions before commissioning the unit. Please follow the instructions in this manual. This is the only way to ensure safe operation, proper use and long service life.

#### 3.1. Product description

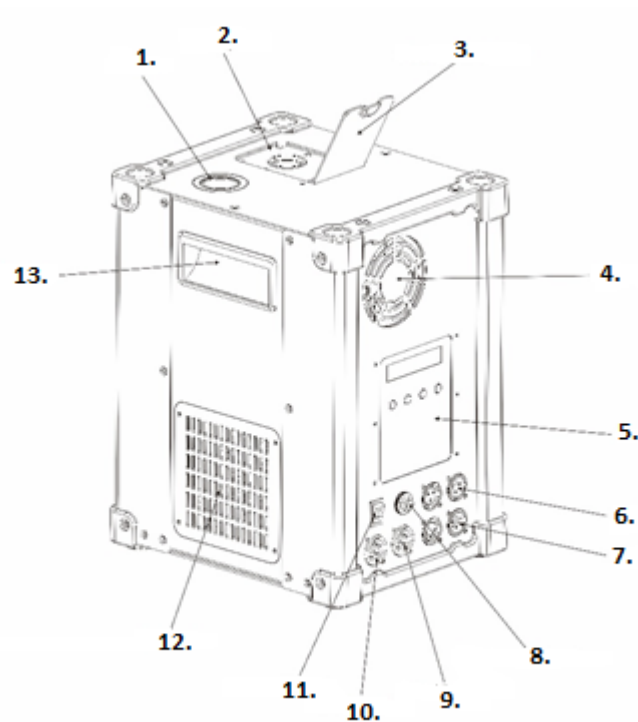

1. Nozzle
2. Feed port
3. Storage bin cover
4. Air Outlet
5. Control panel
6. XLR 3pol INPUT/OUTPUT
7. XLR 5pol INPUT/OUTPUT
8. Fuse
9. Power OUTPUT
10. Power ,INPUT
11. On/Off switch
12. Air Inlet
13. Handle



---

## 4. Before using

Remove before start-up every packing material.

1. After verifying that the unit is intact and complete, please place it on a level surface.
2. Connect the device to the power supply.
3. The device starts to heat up. This process needs 4 min, meanwhile the display shows „Heating“.
4. The heating process is finished. The display shows „Ready To Work“.
5. Now you have to fill in the granules. More information for this you can read on the packing of the granules. You are only allowed to use the granules of DJ Power.

## 5. Control buttons

Button	Function
<b>MENU</b>	Navigation through the menu.
▲	Increase a value or make a setting.
▼	Decrease a value or make a setting.
<b>ENTER</b>	Back to the root menu.

## 6. User Interface

### 6.1. Status interface

Advice	Meaning
<b>Ready To Work</b> » » » » » » 580	The unit finishes pre-heating. Current temperature is 580°C.
<b>Working</b> » » » » » » 580	The unit is working. Current temperature is 580°C.
<b>Heating</b> » » » » » » 580	The unit is heating. Current temperature is 200°C.
<b>Device Fault E0</b>	The unit stops to over temperature.
<b>Device Fault E1</b>	The unit failed to heat.
<b>Device Fault E2</b>	Feeding motor is protected.
<b>Device Fault E3</b>	Temperature sensor failed.
<b>Device Fault E4</b>	Temperature sensor tripped off.
<b>NO Time E5</b>	The granules are run out soon.
<b>Device Fault E6</b>	Temperature inside the unit is too high.
<b>Device Fault E7</b>	Step motor is not able to reset.
<b>Device Fault E8</b>	The input power frequency is abnormal.

## 6.2.Menu

Menu		Function
Manual Heat	ON/OFF	(De-)Activates the manual operation.
Manual Fountain	ON/OFF	Start the manual operation.
Fountain Height	1-10	Setting the fountain height.
DMX Address Set	1-512	Setting the DMX address.
Surplus Time	XX Min XX Sec	Check out the remaining time of using.

## 6.3.DMX Interface

Display	Meaning
DMX Address Set Ready 1	The unit is ready to work. Current DMX address is 1.
DMX Address Set 1 Heating	The unit is heating. Current DMX address is 1.
DMX Address Set Device Fault 1	The unit failed. Current DMX address is 1.
DMX Address Set No Time 1	Materials are to run out soon. Current DMX address is 1.
DMX Address Set Working 1	The unit is working. Current DMX address is 1.

## 7. Error

When Error Protections are activated, the unit stops working and heating system shuts off automatically. LCD screen displays Error code.

Error		Cause
E0	Over temperature	The temperature is since more than 30s more than 700°C.
E1	Heating failed	The device did not reach the working temperature after 10 min.
E2	Over current protection of the motor	Error of the motor.
E3	Thermocouple failed	Short circuit or wrong connection.
E4	Thermocouple tripped off	Open circuit or no connection.
E5	No enough time	Granules run out soon.
E6	Over temperature inside the unit	The temperature inside the unit is higher than 60°C.
E7	Step motor problem	The step motor is not able to reset.
E8	The working frequency is abnormal.	Electrical network frequency is abnormal.

## 8. Operation

When the unit is in good condition, it can start fountain for 30s continuously, then stops automatically. To prolong the working duration, user needs to re-start the fountain.

### 8.1. Manual Operation

If the displays shows "Ready To Work" press "Menu" until the display shows "Menu Fountain". With the buttons ▲ and ▲ buttons you can choose On/Off.

### 8.2. Operation via DMX

Channel	Value from	Value to	Function
1	0	9	No Function
	10	35	Height 1
	36	60	Height 2
	61	85	Height 3
	86	110	Height 4
	111	135	Height 5
	135	160	Height 6
	161	185	Height 7
	186	210	Height 8
	211	235	Height 9
	236	255	Height 10
2	0	9	Normal operation
	10	60	Clear material
	61	120	EMERGENCY STOP
	121	182	Pre-heat OFF
	183	255	Pre-heat ON

---

## 9. Settings

### 9.1. DMX address

Connected to DMX signal, the unit will display "DMX Address Set" in the LCD screen. Or press "MENU" button till pages "DMX Address Set". Through "▲" and "▼" to set the address

### 9.2. Fan speed setting

Press "MENU" Button till page "Fountain Height". Adjust the fan speed through "▲" and "▼". Maximum speed is 10.

### 9.3. Manual operation

Press "MENU" Button till page "Manual Heat". Turn ON/OFF the heating system through "▲" and "▼"

LCD screen displays "Ready to Work" after the unit finishes heating. Press "MENU" button till page "Manual Fountain". Turn on/OFF the Manual fountain through "▲" and "▼". When the temp is lower than 520°C or the unit failed, this function will shut off automatically.

## 10. RFID card

### 10.1. How to use the card

Tap the IC Card in the card reader area to activate the unit. Each card enables the unit to work 25 minutes. In the meantime, the IC card will be invalid after being read.

### 10.2. How to check the remaining time

Press "Menu" buttons till the page "Surplus Time" to check the remaining time of using. The LCD screen displays "No time" "E5" when there is no enough materials and times up. Tap another new card to re-activate the unit.

---

## 11. Technical data

Voltage	AC 220 V; 50 Hz
Power consumption max.	700 W
Heating-time	3 Minutes
Consumption	14 g/min
Height of the fountains	1-5 Meter
Stand-By Temperature	580°C
Max. Loudness	94 dB
Number of DMX channels	2
Strom in	P-Con



Importer:

B&K Braun GmbH  
Im Stöckmädle 27  
D-76307 Karlsbad  
[www.bkbraun.com](http://www.bkbraun.com)  
[info@bkbraun.com](mailto:info@bkbraun.com)

