



**the  
t.bone**

GigA Pro Pedal Set  
UHF wireless system

Musikhaus Thomann  
Thomann GmbH  
Hans-Thomann-Straße 1  
96138 Burgebrach  
Germany  
Telephone: +49 (0) 9546 9223-0  
E-mail: [info@thomann.de](mailto:info@thomann.de)  
Internet: [www.thomann.de](http://www.thomann.de)

18.10.2018, ID: 437954

# Table of contents

<b>1</b>	<b>General notes</b> .....	<b>5</b>
	1.1 Further information.....	6
	1.2 Notational conventions.....	7
	1.3 Symbols and signal words.....	8
<b>2</b>	<b>Safety instructions</b> .....	<b>10</b>
<b>3</b>	<b>Features</b> .....	<b>15</b>
<b>4</b>	<b>Installation and starting up</b> .....	<b>17</b>
	4.1 General Information.....	17
	4.2 Dealing with lithium batteries.....	19
	4.3 Receiver.....	21
<b>5</b>	<b>Connections and controls</b> .....	<b>23</b>
	5.1 Receiver.....	23
	5.2 Transmitter.....	28
	5.3 Rechargeable battery station.....	29

<b>6</b>	<b>Operating.....</b>	<b>31</b>
6.1	Receiver.....	31
6.2	Transmitter.....	36
<b>7</b>	<b>Technical specifications.....</b>	<b>38</b>
7.1	Receiver.....	38
7.2	Transmitter.....	39
7.3	Rechargeable battery station.....	40
<b>8</b>	<b>Plug and connection assignment.....</b>	<b>41</b>
<b>9</b>	<b>Troubleshooting.....</b>	<b>44</b>
<b>10</b>	<b>Protecting the environment.....</b>	<b>47</b>

# 1 General notes

This manual contains important instructions for the safe operation of the unit. Read and follow the safety instructions and all other instructions. Keep the manual for future reference. Make sure that it is available to all those using the device. If you sell the unit please make sure that the buyer also receives this manual.

Our products are subject to a process of continuous development. Thus, they are subject to change.

## 1.1 Further information

On our website ([www.thomann.de](http://www.thomann.de)) you will find lots of further information and details on the following points:

Download	This manual is also available as PDF file for you to download.
Keyword search	Use the search function in the electronic version to find the topics of interest for you quickly.
Online guides	Our online guides provide detailed information on technical basics and terms.
Personal consultation	For personal consultation please contact our technical hotline.
Service	If you have any problems with the device the customer service will gladly assist you.

## 1.2 Notational conventions

This manual uses the following notational conventions:

### Letterings

The letterings for connectors and controls are marked by square brackets and italics.

**Examples:** *[VOLUME]* control, *[Mono]* button.

### Displays

Texts and values displayed on the device are marked by quotation marks and italics.

**Examples:** *'24ch'*, *'OFF'*.

### Instructions

The individual steps of an instruction are numbered consecutively. The result of a step is indented and highlighted by an arrow.

#### Example:

- 1.** ▶ Switch on the device.
- 2.** ▶ Press *[Auto]*.  
⇒ Automatic operation is started.
- 3.** ▶ Switch off the device.

## 1.3 Symbols and signal words

In this section you will find an overview of the meaning of symbols and signal words that are used in this manual.



Signal word	Meaning
<b>DANGER!</b>	This combination of symbol and signal word indicates an immediate dangerous situation that will result in death or serious injury if it is not avoided.
<b>WARNING!</b>	This combination of symbol and signal word indicates a possible dangerous situation that can result in death or serious injury if it is not avoided.
<b>NOTICE!</b>	This combination of symbol and signal word indicates a possible dangerous situation that can result in material and environmental damage if it is not avoided.
Warning signs	Type of danger
	Warning – danger zone.

## 2 Safety instructions

### **Intended use**

This device is intended to be used for the wireless transmission of audio signals from microphones or instruments to amplifiers or active speakers. Use the device only as described in this user manual. Any other use or use under other operating conditions is considered to be improper and may result in personal injury or property damage. No liability will be assumed for damages resulting from improper use.

This device may be used only by persons with sufficient physical, sensorial, and intellectual abilities and having corresponding knowledge and experience. Other persons may use this device only if they are supervised or instructed by a person who is responsible for their safety.

**Safety**



**DANGER!**

**Danger for children**

Ensure that plastic bags, packaging, etc. are disposed of properly and are not within reach of babies and young children. Choking hazard!

Ensure that children do not detach any small parts (e.g. knobs or the like) from the unit. They could swallow the pieces and choke!

Never let children unattended use electrical devices.



**NOTICE!**

**Operating conditions**

This device has been designed for indoor use only. To prevent damage, never expose the device to any liquid or moisture. Avoid direct sunlight, heavy dirt, and strong vibrations.



### **NOTICE!**

#### **External power supply**

The device is powered by an external power supply. Before connecting the external power supply, ensure that the input voltage (AC outlet) matches the voltage rating of the device and that the AC outlet is protected by a residual current circuit breaker. Failure to do so could result in damage to the device and possibly the user.

Unplug the external power supply before electrical storms occur and when the device is unused for long periods of time to reduce the risk of electric shock or fire.



### **NOTICE!**

#### **Risk of fire due to incorrect polarity**

Incorrectly inserted batteries may destroy the device or the batteries.

Ensure that proper polarity is observed when inserting batteries.



**NOTICE!**

**Possible damage by leaking batteries**

Leaking batteries can cause permanent damage to the device.

Take batteries out of the device if it is not going to be used for a longer period.



**NOTICE!**

**Possible damage due to incorrect storage**

Deep discharge can cause batteries to become permanently damaged or lose some of their capacity.

Before prolonged rest periods, charge the batteries to around 50 % of their capacity and then switch the equipment off. Store the equipment at a temperature between 10 °C and 32 °C in as dry an environment as possible. During extended storage periods, charge the batteries to 50 % approximately every three months.



### **NOTICE!**

#### **Possible staining**

The plasticiser contained in the rubber feet of this product may possibly react with the coating of your parquet, linoleum, laminate or PVC floor and after some time cause permanent dark stains.

In case of doubt, do not put the rubber feet directly on the floor, but use felt-pad floor protectors or a carpet.

## 3 Features

The UHF Wireless System GigA Pro Pedal Set consists of the following components:

- GigA Pro pedal receiver:
  - Built-in antenna for optimum reception quality
  - Compatible with all transmitters of the GigA series
  - Automatic frequency scan, up to eight frequencies in parallel
  - Infrared interface for sending the frequency selection from the receiver to the transmitter (ACT sync)
  - Outputs:
    - Line Out: XLR socket, 2 × 1/4" phone socket
    - Tuner Out: 1/4" phone socket
  - Power supply: 12 V  $\overline{\text{DC}}$ , a suitable power supply is included
  - Up to 32 predefined programmes for each transmitter, use the foot switch or the jog wheel to select.
  - Operating via buttons, jog wheel, foot switch and display on the unit
  - Practical display of the selected programme by big coloured LEDs
  - Cable tone function to simulate 14 different cable lengths
  - Anti-feedback function

- Acoustic-response function
- Robust metal pedal board housing
- GigA Pro Plug On instrument transmitter:
  - Replaceable lithium-ion rechargeable battery operation
  - Charging contacts for battery charging station GigA Pro MP24
  - Three-digit display for battery capacity
  - Flexible stub antenna
  - Screwed adapter from 3.5 mm to 1/4" phone socket
- Battery charging station GigA Pro MP24
- Extension instrument cable, metal clip for guitar strap

The system operates at 2.400 GHz ... 2.4835 GHz and is worldwide free of charge and registration.



## 4 Installation and starting up

### 4.1 General Information

Unpack and carefully check that there is no transportation damage before using the unit. Keep the equipment packaging. To fully protect the device against vibration, dust and moisture during transportation or storage use the original packaging or your own packaging material suitable for transport or storage, respectively.

Create all connections while the device is off. Use the shortest possible high-quality cables for all connections. Take care when running the cables to prevent tripping hazards.

### Notes on wireless transmission

- This device utilizes frequencies that are not harmonized within the European Union (EU) and therefore may only be used in certain EU member states. In all European countries, the frequencies used for the transmission of audio signals are strictly regulated. Before you start, make sure the frequencies are allowed in the respective country and check whether the operation must be reported to the appropriate authority.  
For more information, please visit: <http://www.thomann.de>.
- Make sure that transmitter and receiver are both tuned to the same channel.
- Never set multiple transmitters to the same channel.
- Make sure that there are no metal objects between the transmitter and receiver.
- Avoid interference from other radio or in-ear systems.

## 4.2 Dealing with lithium batteries

**WARNING!****Incorrect handling of lithium batteries can result in injury**

In the event of a short circuit, overheating or mechanical damage, lithium batteries can cause severe injuries.

Follow the advice on the correct handling of lithium batteries in the present section.

When handled correctly and appropriately lithium batteries pose no risk.

Store lithium batteries in a cool, dry place, ideally in the original packaging.

Store lithium batteries away from heat sources (e.g. radiators or sunlight). Lithium batteries are hermetically sealed. Never attempt to open a lithium battery.

If the battery housing is damaged small amounts of the electrolyte may leak out. If this should happen, seal the lithium battery in airtight packaging and wipe up the traces of electrolyte using absorbent paper towels. You must wear protective rubber gloves when doing so. Clean your hands and the affected surface thoroughly with cold water.

Never attempt to recharge non-rechargeable lithium batteries. When charging lithium batteries you must use a suitable charging device intended for the purpose.

Before disposing of the device remove the lithium batteries. Protect used lithium batteries against potential short circuits, e.g. by covering the poles with adhesive tape.

Only use powder extinguishers or other suitable extinguishing agents to extinguish a burning lithium battery.

## 4.3 Receiver

### Connect the voltage supply



#### **NOTICE!**

##### **External power supply**

The device is powered by an external power supply. Before connecting the external power supply, ensure that the input voltage (AC outlet) matches the voltage rating of the device and that the AC outlet is protected by a residual current circuit breaker. Failure to do so could result in damage to the device and possibly the user.

Unplug the external power supply before electrical storms occur and when the device is unused for long periods of time to reduce the risk of electric shock or fire.

First, connect the power adapter to the receiver and then plug the power adapter into the power outlet. Turn on the device using the main switch on the rear panel.

## Connecting audio and starting up

Connect one of the audio outputs of the receiver to your mixer or your amplifier. The following figure shows an example of integrating the device in your stage assembly.

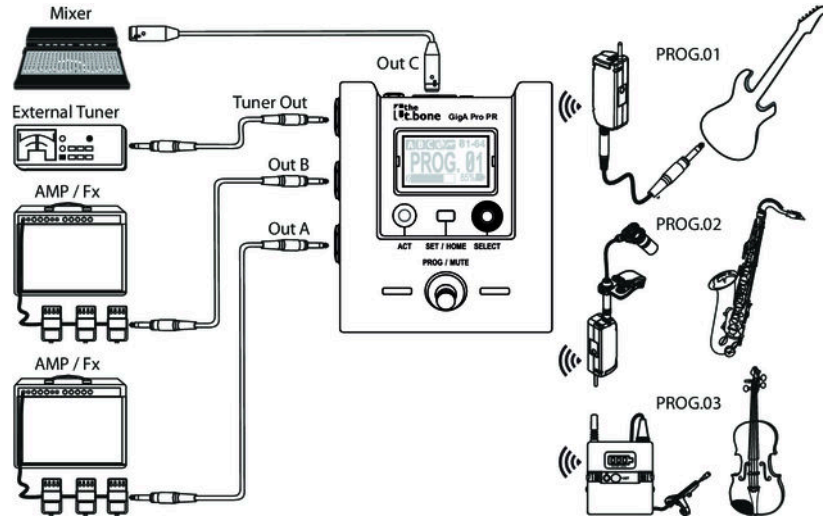

## 5 Connections and controls

### 5.1 Receiver

#### Front panel

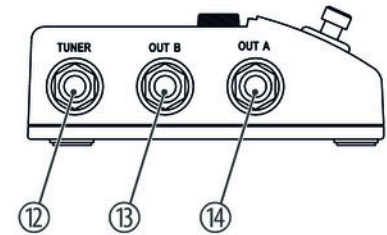
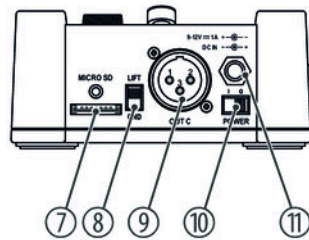
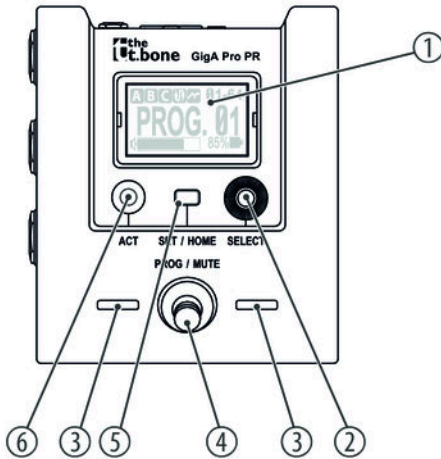

1	Display
2	<i>[SELECT]</i> Press the jog wheel to open the menu and rotate it to select a menu item. Press the jog wheel again to call up the menu item.
3	LEDs to indicate the selected programme The LEDs flash when the device is muted.
4	<i>[PROG / MUTE]</i> Foot switch to select a programme Hold the foot switch pressed for several seconds to mute all outputs.
5	<i>[SET / HOME]</i> Opens or closes the main menu. Press the button strongly to the pressure point, if necessary use e.g. a ballpen.
6	<i>[ACT]</i> Starts the synchronization of the settings with the transmitter
7	<i>[MICRO SD]</i> Interface for an external memory card which can be used to store the settings or for firmware updates.



8	<i>[GND] / [LIFT]</i> Ground / lift switch. If hum is caused by a ground loop, you can use this switch to disconnect the connection between the earth pin of the device and the signal ground of the device.
9	<i>[OUT C]</i> Male XLR panel connector as symmetrical audio signal output C for direct connection with a mixer, a power amplifier, or a recording device.
10	<i>[POWER]</i> Main switch. Turns the device on and off All previous settings are retained even when you switch the device off and disconnect it from the mains.
11	<i>[DC IN]</i> Connector for the supplied power supply adapter
12	<i>[TUNER]</i> External tuner output, designed as 1/4" phone socket (mono, unbalanced)

13 *[OUT B]*

1/4" phone socket as unbalanced audio signal output B for direct connection to a mixer, a power amplifier, or recording device.

14 *[OUT A]*

1/4" phone socket as unbalanced audio signal output A for direct connection to a mixer, a power amplifier, or recording device.

## Display

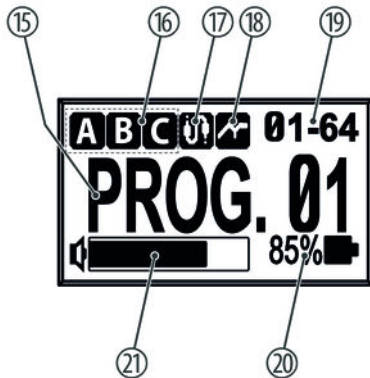

15	Selected programme with the assigned name
16	Shows the outputs to which the audio signal is passed. When the device is muted, the display shows 'ALLOFF'.
17	Shows that the cable simulation is enabled.
18	Shows that a filter to attenuate acoustic feedback or a loudness setting to avoid undesired resonances is enabled.
19	Shows the used radio channel and the used ID.
20	Shows the battery status of the transmitter from which the device just received a signal.
21	Level display for the audio signal. If the transmitter is disabled or muted, the display shows 'TxMute!'.

## 5.2 Transmitter

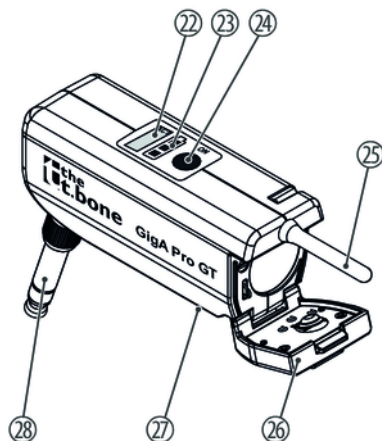

22	[ACT] Infrared sensor
23	Battery status indicator If the last remaining segment lights up red, at most 25% of the battery capacity remains.
24	[ON] Main switch. Press the switch for several seconds to switch the device on or off.
25	Antenna
26	Snap locks for the battery compartment.
27	Charging contacts.
28	Phone socket (mono) for connecting to your instrument You can screw an adapter to a 1/4" phone socket or the supplied connection cable on the 3.5 mm phone plug.

### 5.3 Rechargeable battery station

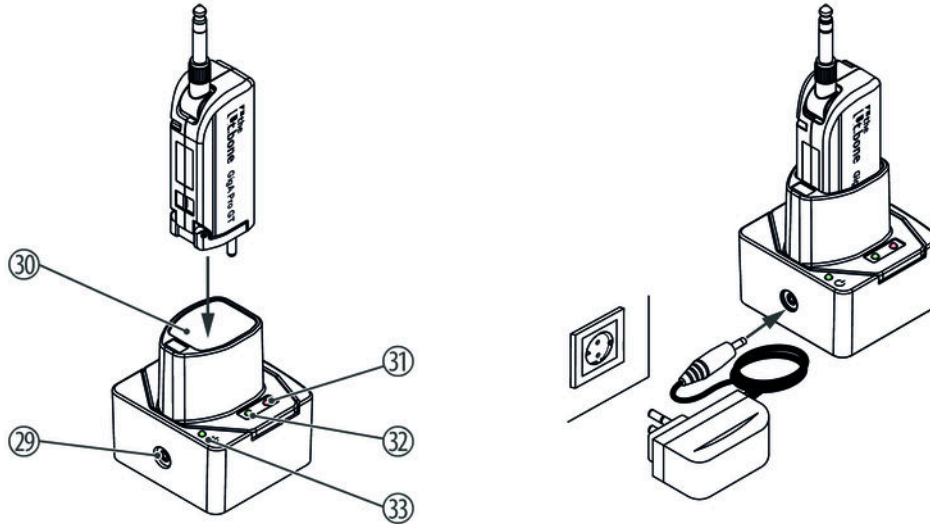

29	Connector for the supplied power supply adapter
30	Charging slot
31.32	Charging indication The red LED lights during charging, while the green LED will light up when the device is charged.
33	Power indicator. Lights up when the device is connected to the power supply.

## 6 Operating

### 6.1 Receiver

#### normal operation

Turn the jog wheel or press the foot switch repeatedly until the desired transmitter 1, 2, or 3 is selected. The display shows the settings of this transmitter (programme). The LEDs light up in the colour which corresponds to this transmitter.

#### Synchronizing transmitter and receiver

1. ➤ Turn on the transmitter and point the infrared sensor of the transmitter directly at the receiver.
2. ➤ Press [ACT].
  - ⇒ The message 'ACT...' in the display indicates that the synchronization is running.
3. ➤ After successful synchronization, the display appears in the default state. The battery status of the transmitter with which you just synchronized is now displayed here.

If the synchronization has failed, the message 'FAIL' appears. In this case, hold the transmitter closer to the receiver and restart the synchronization.

### Programming mode

- 1.** ▶ Use the jog wheel or the foot switch to select the transmitter which settings you want to edit.
- 2.** ▶ Press *[SET/HOME]* to switch to the programming mode.
- 3.** ▶ Turn the jog wheel until the desired menu item is highlighted in the display.  
Press the jog wheel to call up the menu item.  
⇒ The last set value for this menu item is shown.
- 4.** ▶ Use the jog wheel to select a new value.  
Press the jog wheel to confirm the selection.  
⇒ The menu is closed, the display shows the set value.
- 5.** ▶ Repeat the steps for all menu items which should be changed.
- 6.** ▶ Press *[SET/HOME]* to exit the programming mode.

The following table shows the setting options.



Menu item	Value range	Meaning
'AntiFBACK'	32 Hz... 330 Hz	Feedback filter Selecting one of 31 frequencies to be attenuated to avoid whistling noise caused by acoustic feedback.
'CableTone'	10 ' (3 m)...100 ' (30 m)	Selecting a virtual cable length to simulate the influences of a traditional cable on the transmission between instrument and amplifier.
'AcousticRSP'	OFF, 1...31	Selecting a loudness setting to reduce undesired resonances.
'Gain'	-10 dB...+20 dB	Setting the volume
'Phase'	'NORM.', 'INV.'	Toggling the phase of the signal
'Rename'		Rename the programme The name can consist of up to eight alphanumeric characters.  When all digits of the name is correct, select the option 'Done' and press the jog wheel.
'Channel&ID'	01...12, 01...64	Manual setting of channel and ID The ID adjustable in addition to the channel increases the transmission reliability.

Menu item	Value range	Meaning
'Output'	'A', 'B', 'C', 'A+B', 'A+C', 'B+C', 'A+B+C',	Selecting the outputs to which the signal should be passed. Each output can be enabled or disabled separated from the others.
'SetColor'	'Green', 'Red', 'Blue', 'Orange', 'Purple', 'Aqua', 'White', 'Yellow'	Selecting a colour for the LEDs.
'Channel Scan'		<p>Starts a check of the available radio channels. The display shows the result with a graphical representation. The check runs until you press the jog wheel.</p> <p>The evaluation result is displayed. Here, the vertical bars indicate how strong the interferences on the respective channel are. The 'T+' symbol indicates the currently used channel. The 'T!' symbol is displayed for channels that are occupied by other devices. The symbols flash for the channel currently being tested.</p> <p>Turn the jog wheel to select another channel. The number of the set channel is underlined. Press the jog wheel to confirm the selection.</p>

<b>Menu item</b>	<b>Value range</b>	<b>Meaning</b>
<i>'Remove?'</i>		Removing one programme or all programmes at a time. Except programme 1, all programmes can be removed.
<i>'New?'</i>		Adding a programme. You can create up to 32 programmes.
<i>'Version?'</i>		The display shows the current software version used by the device.

## 6.2 Transmitter

### Engaging transmitter

1. ➤ Connect the transmitter to your instrument before switching the transmitter on. If the transmitter should not be connected directly to the instrument, use the screwable extension cable. Use the practical metal clip to fix the transmitter at the guitar strap.
2. ➤ Press *[ON]*.
  - ⇒ The battery level indicator and the button *[AF]* light up.
3. ➤ If the last remaining segment of the battery level indicator lights up red, at most 25 % of the battery capacity remains.

In this case, recharge the transmitter in the charger or replace the empty battery with a charged one.

### Turning the transmitter off

Press *[ON]* for several seconds until the battery level indicator goes out.

## Battery replacement

1. ▶ Turn the transmitter off.
2. ▶ Press the snap lock forward to open the battery compartment cover.
3. ▶ Remove the empty battery and replace it with a charged one. Observe the correct polarity. The positive pole points into the device in the direction of the phone socket.
4. ▶ Close the battery compartment and turn the transmitter back on.
5. ▶ Should the transmitter also fail to work with a freshly charged battery, turn the transmitter on and off again.

## 7 Technical specifications

### 7.1 Receiver

Line outputs	XLR chassis plug, balanced 2× 1/4" phone socket (unbalanced)
Tuner output	1/4" phone socket (unbalanced)
Output level adjustment	-10 dB ... +20 dB
Frequency range	2.400 GHz ... 2.4835 GHz
Sensitivity	-95 dBm
Audio sampling rate	24 bit / 44.1 kHz
NF frequency response	20 Hz ... 20 kHz (-2 dB)
THD (1 kHz)	0.1 %
Signal-to-noise ratio	> 118 dB (A)

Voltage supply	Power adapter (12 – 15 V $\overline{\text{AC}}$ / 1000 mA, positive pole via inner or outer contact)
Power consumption	1.6 W
Dimensions (W × H × D, without antennas)	110 mm × 50 mm × 130 mm (1 RU)
Weight	0.85 kg

## 7.2 Transmitter

Frequency range	2.400 GHz ... 2.4835 GHz
Maximum transmission power	10 mW
Maximum input level	6.5 dBV
Input impedance	1.0 M $\Omega$
Range (free field)	Up to 100 m
Voltage supply	1 lithium ion battery ICR-18500, 3.7 V, 1400 mAh

Operating time	> 1 h (after 25 minutes charging time), > 10 h (after four hours charging time)
Dimensions (W × H × D, without antenna)	84 mm × 35 mm × 29 mm
Weight	61 g

### 7.3 Rechargeable battery station

Suitable for	Lithium-ion rechargeable battery ICR-18500, 3.7 V, 1400 mAh
Charging method	Electronic control
Charging current	approx. 500 mA
Voltage supply	5 V $\overline{\text{---}}$ via the supplied power adapter
Current consumption	approx. 550 mA
Dimensions (W × H × D)	72 mm × 76.5 mm × 68 mm
Weight	162 g



## 8 Plug and connection assignment

### Introduction

This chapter will help you select the right cables and plugs to connect your valuable equipment in such a way that a perfect sound experience is ensured.

Please note these advices, because especially in 'Sound & Light' caution is indicated: Even if a plug fits into the socket, an incorrect connection may result in a destroyed power amp, a short circuit or 'just' in poor transmission quality!

### Balanced and unbalanced transmission

Unbalanced transmission is mainly used in semi-professional environment and in hifi use. Instrument cables with two conductors (one core plus shielding) are typical representatives of the unbalanced transmission. One conductor is ground and shielding while the signal is transmitted through the core.

Unbalanced transmission is susceptible to electromagnetic interference, especially at low levels, such as microphone signals and when using long cables.

In a professional environment, therefore, the balanced transmission is preferred, because this enables an undisturbed transmission of signals over long distances. In addition to the conductors 'Ground' and 'Signal', in a balanced transmission a second core is added. This also transfers the signal, but phase-shifted by 180°.

Since the interference affects both cores equally, by subtracting the phase-shifted signals, the interfering signal is completely neutralized. The result is a pure signal without any noise interference.

### 1/4" TS phone plug (mono, unbalanced)



1	Signal
2	Ground, shielding

### 1/4" TRS phone plug (mono, balanced)



1	Signal (in phase, +)
2	Signal (out of phase, -)
3	Ground

**XLR plug (balanced)**

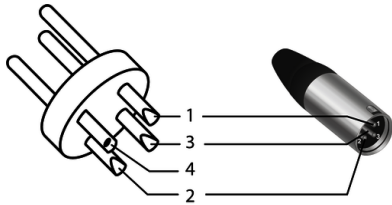

1	Ground, shielding
2	Signal (in phase, +)
3	Signal (out of phase, -)
4	Shielding on plug housing (option)

## 9 Troubleshooting

In the following we list a few common problems that may occur during operation. We give you some suggestions for easy troubleshooting:

Symptom	Remedy
No sound	<ol style="list-style-type: none"> <li>1. Check the power supply of transmitter and receiver.</li> <li>2. Make sure that transmitter and receiver are operating in the same frequency range. The frequency range can be found on the devices.</li> <li>3. Are transmitter and receiver set to the same channel and ID?</li> <li>4. Test the connection between the receiver and the connected audio device (amplifier, mixer). Is the connected audio device turned on and does the signal level at the output of the receiver match the input requirements of the audio device?</li> <li>5. See if the audio transmission works when you move the transmitter closer to the receiver.</li> <li>6. Make sure that no metal objects near the transmitter or receiver obstruct the transmission.</li> </ol>
Transmission is interrupted.	<ol style="list-style-type: none"> <li>1. Modify the orientation of the antennas.</li> <li>2. If you use more than one wireless system at the same time, check the used frequencies and channels.</li> <li>3. Interference can also be caused by other radio or in-ear systems.</li> </ol>

If the procedures recommended above do not succeed, please contact our Service Center. You can find the contact information at [www.thomann.de](http://www.thomann.de).

## 10 Protecting the environment

### Disposal of the packaging material



For the packaging, environmentally friendly materials have been chosen that can be supplied to normal recycling.

Ensure that plastic bags, packaging, etc. are properly disposed of.

Do not just dispose of these materials with your normal household waste, but make sure that they are collected for recycling. Please follow the notes and markings on the packaging.

### Disposal of batteries



Batteries do contain some hazardous chemicals so they should not be thrown away with the normal household waste. They should be returned to the manufacturer for disposal or recycled elsewhere in accordance with your local regulations.

Remove lithium batteries from the device before disposal. Protect used lithium batteries against short circuit, for example by taping the poles.

### Disposal of your old device



This product is subject to the European Waste Electrical and Electronic Equipment Directive (WEEE) in its currently valid version. Do not dispose with your normal household waste.

Dispose of this device through an approved waste disposal firm or through your local waste facility. When discarding the device, comply with the rules and regulations that apply in your country. If in doubt, consult your local waste disposal facility.









Musikhaus Thomann · Hans-Thomann-Straße 1 · 96138 Burgebrach · Germany · [www.thomann.de](http://www.thomann.de)